

G. L. STUEBNER.
 DUMPING BUCKET.
 APPLICATION FILED FEB. 12, 1910.

999,903.

Patented Aug. 8, 1911.

3 SHEETS—SHEET 2.

Fig 3

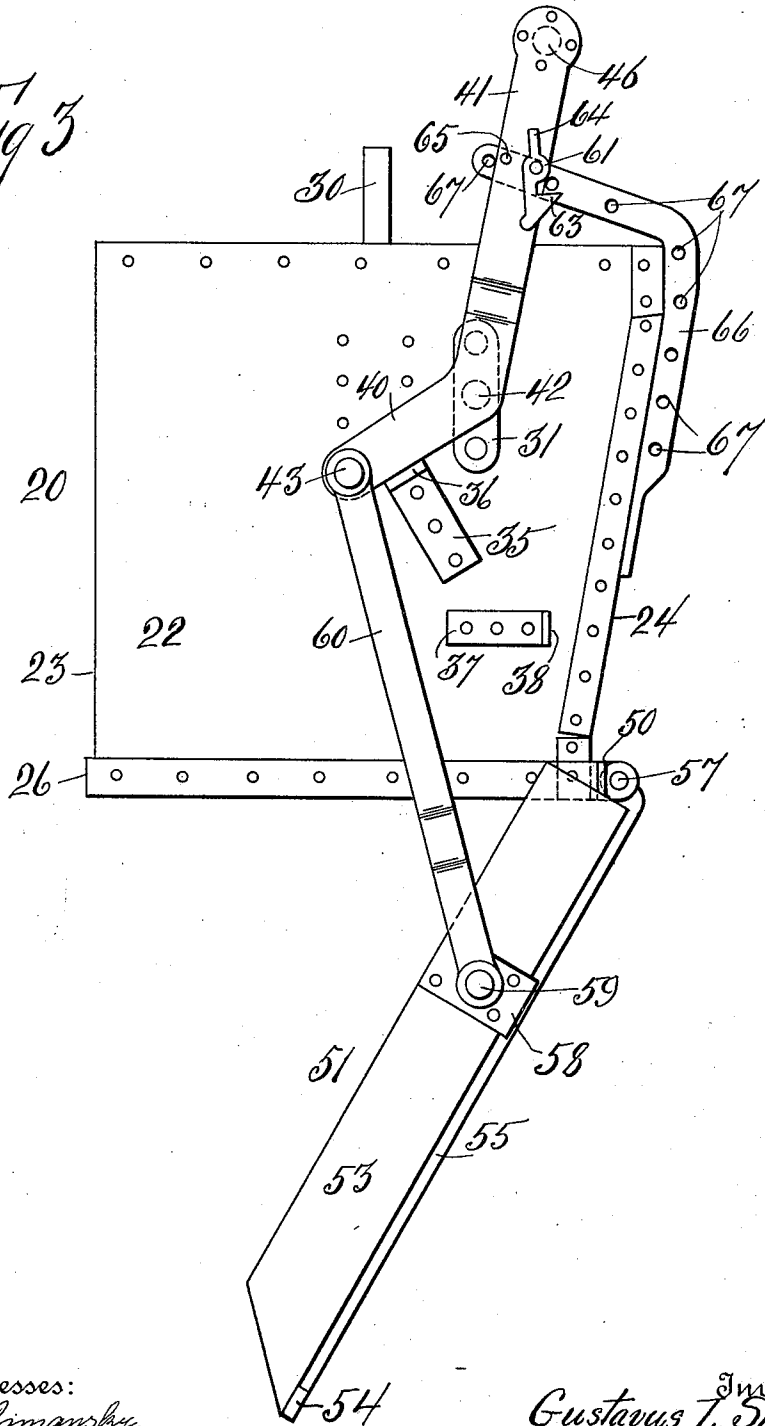

Witnesses:
 Martin Zimansky
 John J. Millin

Inventor
 Gustavus L. Stuebner
 By his Attorney
 A. de Romeville

G. L. STUEBNER.
 DUMPING BUCKET.
 APPLICATION FILED FEB. 12, 1910.

999,903.

Patented Aug. 8, 1911.

3 SHEETS—SHEET 3.

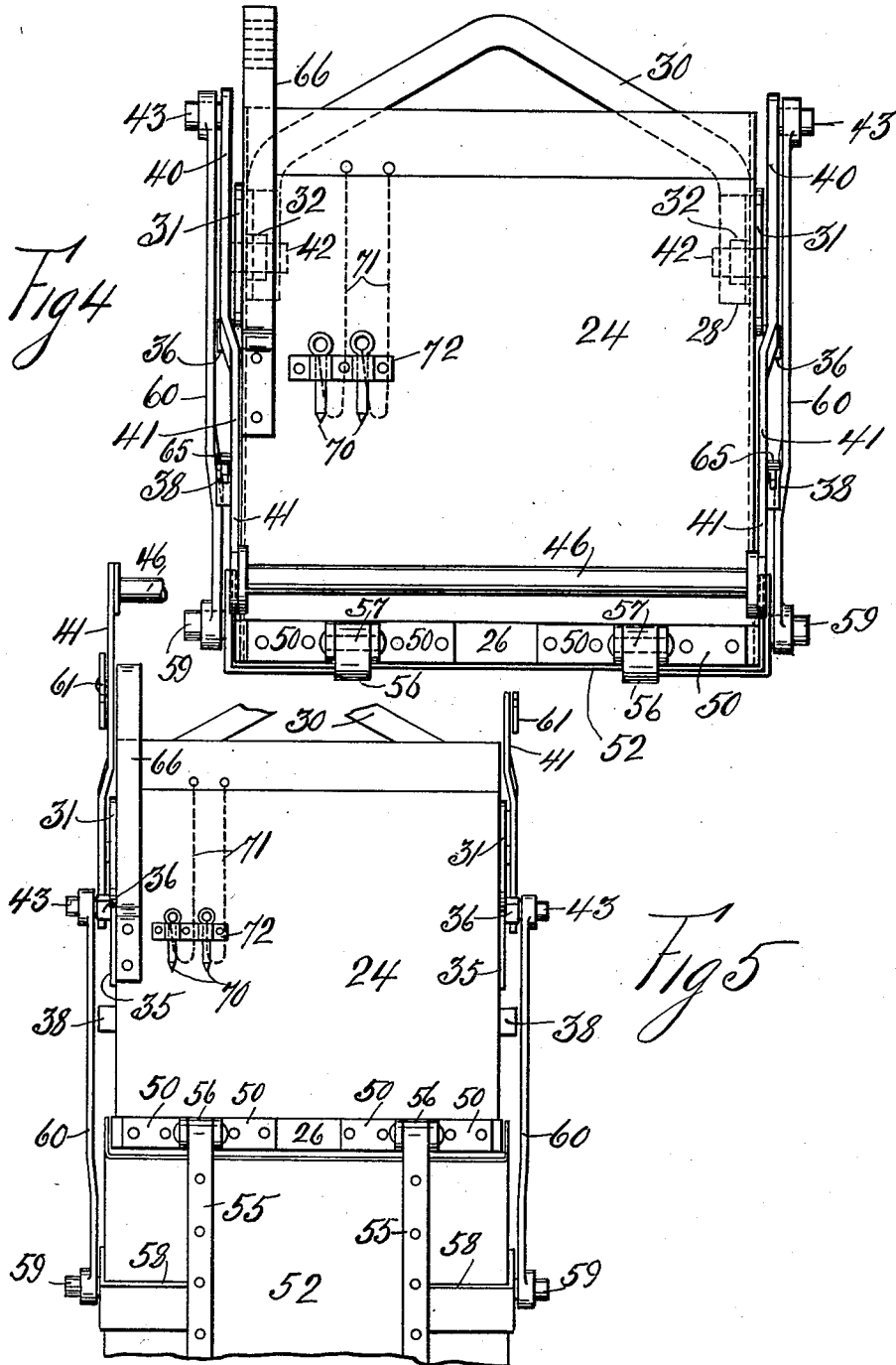

Witnesses:
 Martin Zimansky
 John J. Millin

Inventor
 Gustavus L. Stuebner
 By his Attorney
 A. S. Romerville

UNITED STATES PATENT OFFICE.

GUSTAVUS L. STUEBNER, OF FLUSHING, NEW YORK.

DUMPING-BUCKET.

999,903.

Specification of Letters Patent.

Patented Aug. 8, 1911.

Application filed February 12, 1910. Serial No. 543,464.

To all whom it may concern:

Be it known that I, GUSTAVUS L. STUEBNER, a citizen of the United States, and a resident of Flushing, in the county of Queens and State of New York, have invented certain new and useful Improvements in Dumping-Buckets, of which the following is a specification.

This invention relates to a bottom dumping bucket that can be used for handling various kinds of materials. Its organization comprises a bucket having a body of any suitable form and a bottom pivoted thereto with a linked locking and suspending device, the elements of which coact to lock the bottom in place when in proper position. Said locking and suspending device is further characterized, by increasing the locking action thereof with the increase of the weight of the charge or load in the bucket. Secondary safety locking devices are connected up with the bucket.

In the drawings Figure 1 shows a side view of a bucket exemplifying the invention, with the bottom locked in its closed position, Fig. 2 represents a top plan view of Fig. 1, Fig. 3 is a side view of the bucket with the bottom in its lowered position, Fig. 4 shows a right hand end view of Fig. 1, and Fig. 5 shows a partial right hand side view of Fig. 3 on a reduced scale.

The body of the bucket is designated generally by the numeral 20, with sides 21, 22, front end 23 and rear end 24. A reinforcing band 25 is fastened to the inner faces of the upper portions of the sides and ends of the body of the bucket, and a reinforcing band 26 is fastened to the outer faces of said sides and ends at the lower portions thereof. Angle irons 28 extend from the sides 21, 22 and secure the bail 30 in place. Journal brackets 31 are fastened to the outer faces of the sides 21, 22, and have extending therefrom the journal bearings 32 that extend through said sides. Stop brackets 35 with the stop flanges 36, and locking brackets 37 with locking flanges 38 extend from said sides 21 and 22. Operating and locking bell cranks have each the arms 40, 41 with the pivot 42 and pin 43. The said pivots 42 are supported in the journal bearings 32, cotter pins 44 holding the pivots 42 in place. To the outer ends of the arms 40 are riveted the flanged ends 45 of the operating handle 46. Hinge brackets 50 extend from the lower rear end portion of the body of the

bucket, being riveted to the reinforcing band 26.

A swinging bottom door for the bucket generally designated by the numeral 51, 60 comprises the main plate 52 with the sides 53. An end stiffening bar 54 and longitudinal stiffening bars 55 are fastened to the lower surface of the said plate 52. Hinge ends 56 are formed with the stiffening bars 55, and hinge pins 57 connect said ends with the hinge brackets 50. Stiffening angles 58 with the pivots 59 are fastened to the said main plate 52 and sides 53. Connecting links 60 are respectively supported on the pins 43 and pivots 59. Latches 61 are pivoted on pivots 62 extending from the arms 41 of the operating and locking bell cranks. The said latches have each a nose 63 at one end and a handle 64 on the other. Stop pins 65 on the arms 41 are located in the paths of the handle 64. A locking bar 66 with the openings 67 is fastened to the rear end 24 and extends forwardly above the upper edge of the body of the bucket. Locking pins 80 have extending therefrom the chains 71, which latter are fastened to the rear end 24 of the bucket. A pin support 72 holds said pins in place when not in operative positions.

To use the invention and with the door 51 in its closed position as particularly shown in Fig. 1, the body of the bucket is filled with its charge, the theoretical line connecting the pins 43 and pivots 59 when located as shown in said Fig. 1 being on the right of the axial center of the pivots 42. In this location of the elements the swinging bottom door is locked in position, the noses 63 of the latches 61 engaging the flanges 38 of the brackets 37. If it is desired to dump the bucket the latches 61 are disengaged from the locking brackets 37, and the operating handle 46 is raised, and if raised to its uppermost position, the parts will be located as shown in Fig. 3 where the arms 41 of the operating and locking bell cranks bear against the stop flanges 36 of the brackets 35. There is thus obtained the greatest inclination between swinging bottom door and the lower edge of the body of the bucket. Should it be desired to locate the bottom door in a different angular position one of the pins 70 is located in one of the openings 67 of the locking bar 66, so that any desired angle of inclination can be given to the door 51, to secure the proper

velocity and direction of discharge from the bucket.

It will be noted that the swinging end of the bottom door extends for some distance beyond the front end 23 of the body of the bucket, by virtue of which said bottom door performs the function of a chute when the contents of the bucket are discharged therefrom.

The invention may be modified by eliminating one of the latches 61.

Having described my invention what I desire to secure by Letters Patent and claim is:

1. In a bucket the combination of a door hinged thereto, a pair of operating and locking bell cranks pivoted to the body of the bucket, a connecting link connecting one end of one arm of each bell crank with a pivot on the said door, a locking bar extending from the body of the bucket, means to engage one of the arms of one of the bell cranks in various positions with respect to said locking bar to incline the bottom at various angles with the bottom edge of the body of the bucket, and a latch on one of the arms of one of the bell cranks to lock said arm with the body of the bucket.

2. In a bucket the combination of a door hinged thereto, a pair of operating and locking bell cranks pivoted to the body of the bucket, a connecting link on each side of the bucket with one end pivoted to said door and the other end pinned to an arm of its accompanying bell crank, and a stop bracket on each side of the body of the bucket in the path of one of the arms of its accompanying bell crank for the latter to bear upon when the door is in its lowered position.

3. In a bottom dumping bucket the combination of a door hinged to the lower portion of one of the ends thereof and the other

end of said door extending beyond the other end of the bucket, a pair of operating and locking bell cranks pivoted to the body of the bucket, a connecting link on each side of the bucket with one end pinned to an arm of its accompanying bell crank and the other end pivoted to said door, means to lock the bell cranks in various positions and a secondary locking device between one of the bell cranks and the body of the bucket.

4. In a bottom dumping bucket the combination of a body, a door hinged to the lower portion thereof, a locking and operating bell crank pivoted to each side of the bucket, a connecting link on each side of the bucket with one end pinned to one arm of its accompanying bell crank and the other end pivoted to the said door, a stop bracket on each side of the bucket in the path of an arm of its accompanying bell crank, a locking bar extending from the body of the bucket, and a stop pin for openings in the locking bar to locate said pin in the path of one of the arms of one of the bell cranks.

5. In a bottom dumping bucket the combination of a door hinged to the lower portion thereof, an operating and locking bell crank pivoted to each side of the bucket, a connecting link on each side of the bucket with one end pinned to an arm of its accompanying bell crank and the other end pivoted to said door, a latch pivoted to one of the arms of the bell crank and a locking bracket on the bucket to engage said latch.

Signed at borough of Queens in the county of New York and State of New York this 4th day of February A. D. 1910.

GUSTAVUS L. STUEBNER.

Witnesses:

HEATON MATHISON,
GEO. A. STUEBNER.