



(51) International Patent Classification:

H04W 72/12 (2009.01) H04W 72/04 (2009.01)

(21) International Application Number:

PCT/EP2018/057528

(22) International Filing Date:

23 March 2018 (23.03.2018)

(25) Filing Language:

English

(26) Publication Language:

English

(30) Priority Data:

62/480,849 03 April 2017 (03.04.2017) US

(71) Applicant: TELEFONAKTIEBOLAGET LM ERICSSON (PUBL) [SE/SE]; 164 83 Stockholm (SE).

(72) Inventors: ÅSTRÖM, Magnus; Guldåkersvägen 12, 224 80 LUND (SE). LINDOFF, Bengt; Öresundsvägen 5, 237 35 BJÄRRED (SE). ALRIKSSON, Peter; Fridagatan 10, 242 31 HÖRBY (SE).

(74) Agent: ERICSSON; Patent Development, Torshamnsgatan 21-23, 164 80 STOCKHOLM (SE).

(81) Designated States (unless otherwise indicated, for every kind of national protection available): AE, AG, AL, AM, AO, AT, AU, AZ, BA, BB, BG, BH, BN, BR, BW, BY, BZ, CA, CH, CL, CN, CO, CR, CU, CZ, DE, DJ, DK, DM, DO, DZ, EC, EE, EG, ES, FI, GB, GD, GE, GH, GM, GT, HN,

HR, HU, ID, IL, IN, IR, IS, JO, JP, KE, KG, KH, KN, KP, KR, KW, KZ, LA, LC, LK, LR, LS, LU, LY, MA, MD, ME, MG, MK, MN, MW, MX, MY, MZ, NA, NG, NI, NO, NZ, OM, PA, PE, PG, PH, PL, PT, QA, RO, RS, RU, RW, SA, SC, SD, SE, SG, SK, SL, SM, ST, SV, SY, TH, TJ, TM, TN, TR, TT, TZ, UA, UG, US, UZ, VC, VN, ZA, ZM, ZW.

(84) Designated States (unless otherwise indicated, for every kind of regional protection available): ARIPO (BW, GH, GM, KE, LR, LS, MW, MZ, NA, RW, SD, SL, ST, SZ, TZ, UG, ZM, ZW), Eurasian (AM, AZ, BY, KG, KZ, RU, TJ, TM), European (AL, AT, BE, BG, CH, CY, CZ, DE, DK, EE, ES, FI, FR, GB, GR, HR, HU, IE, IS, IT, LT, LU, LV, MC, MK, MT, NL, NO, PL, PT, RO, RS, SE, SI, SK, SM, TR), OAPI (BF, BJ, CF, CG, CI, CM, GA, GN, GQ, GW, KM, ML, MR, NE, SN, TD, TG).

Published:

— with international search report (Art. 21(3))

(54) Title: SIGNALING DOWNLINK CONTROL INFORMATION IN A WIRELESS COMMUNICATION NETWORK

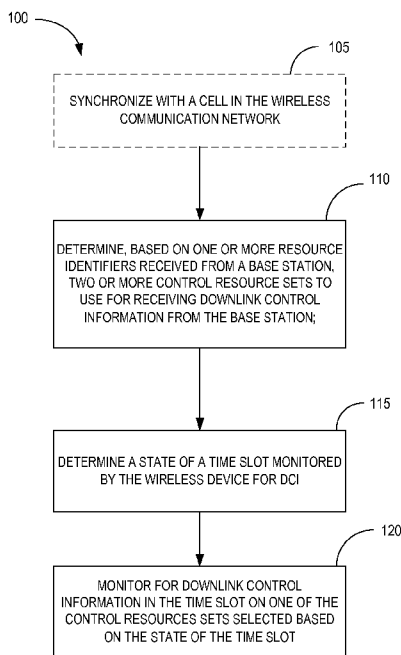

FIG. 3

(57) Abstract: A wireless device is configured with or allocated two or more control resource sets for receiving downlink control information from a base station or cell. The two or more control resource sets correspond to two or more possible states of a time slot used for downlink transmission. The wireless device determines the state of a time slot and selects one or the two or more control channel resource sets to monitor for DCI depending on the state of the time slot. In one exemplary embodiment, the time slot has two possible states and the state of the time slot is determined by the presence or absence of an SS block.



SIGNALING DOWNLINK CONTROL INFORMATION IN A WIRELESS COMMUNICATION NETWORK

TECHNICAL FIELD

The present disclosure relates generally to downlink transmissions in wireless
5 communication networks and, more particularly, to methods of transmitting and receiving
downlink control information.

BACKGROUND

Currently the 5th Generation (5G) of cellular systems, sometimes referred to as
Next Radio (NR), is being standardized by the Third Generation Partnership Project
10 (3GPP). NR is developed for maximum flexibility to support multiple and substantially
different use cases. In addition to typical mobile broadband (MBB) services, NR
networks are designed to support Machine-Type Communications (MTC), Ultra Low
Latency Critical Communications (ULLCC), side link Device-to-Device (D2D)
communications, and several other use cases. NR is also expected to support carrier
15 frequencies from sub-GHz to 100 GHz.

All these requirements put extreme challenges on the system design. One
important parameter in managing such vastly different use cases is the subcarrier
spacing (SCS), i.e. the distance between the sub-carriers (resource elements) in an
Orthogonal Frequency Division Multiplexing (OFDM) signal. The SCS determines the
20 sensitivity to coherence time and coherence frequency in terms of samples and
subcarriers that, in turn, determines sensitivity to Doppler, and changing channel
conditions. It has been determined that several SCSs should be accepted, e.g., 15 kHz,
30 kHz, 60 kHz, 120 kHz and 240 kHz. Typically, lower SCSs are used at lower carrier
frequencies and higher SCSs at higher carrier frequencies. The SCS also has an impact
25 on the symbol time length. For instance, if SCS is 15 kHz, one OFDM symbol (excl. the
cyclic prefix (CP)) is $1/15 \text{ kHz} = 66.67 \mu\text{s}$, while an OFDM symbol with 30 kHz SCS has
half the symbol time, i.e. $1/30 \text{ kHz} = 33.33 \mu\text{s}$. Therefore, the SCS has an impact of the
symbol sample rate as well.

Synchronization in NR system is similar to the initial synchronization/cell search
30 procedure in existing Long Term Evolution (LTE) systems. The cell transmits a Primary
Synchronization Signal (PSS), giving timing information, a Secondary Synchronization
Signal (SSS) giving cell/beam ID information, and Physical Broadcast Channel (PBCH)

giving information for the wireless device to be able to perform a random access. The PSS, SSS, and PBCH is called a synchronization signal (SS) block in the further discussions below. The SS block may also include a Tertiary Synchronization Signal (TSS) as discussed below.

- 5 To reduce complexity of the wireless device, the SS block may be transmitted with fewer SCS alternatives. At present, the likely candidates are 30 kHz subcarrier spacing below 6 GHz, and 120 or 240 kHz subcarrier spacing above 6 GHz. Furthermore, the SS block is transmitted in slots every 10 or 20 ms. In order to reduce the cell search time, the SS block may be sent on a finite set of sync center frequencies.
- 10 Hence, the SS block may not be transmitted at the system bandwidth (BW) center frequency as in LTE, but instead on one of the fixed sync center frequencies within the system bandwidth specified by a standard.

- In NR, the majority of control signaling will be dedicated, though some information valid for many wireless devices may be signaled via a “common” control
- 15 channel, such as the NR Physical Downlink Control Channel (PDCCH). The common PDCCH will, as in LTE, span the first few OFDM symbols in at least a subset of the time slots. The wireless devices are then configured to monitor at least a subset of the PDCCH indicating potential messages to the wireless device(s). This subset is defined as a number of control resource sets, or CORSETs for short.

- 20 A potential problem arises in time slots where the SS block is transmitted. The SS block is not transmitted in every time slot. In time slots where the SS block is transmitted, the SS block may overlap control channel resources that have been allocated to a wireless device for receiving Downlink Control Information (DCI) on the PDCCH. That is, some of the control channel resources used for transmitting DCI to the
- 25 wireless device on the PDCCH in time slots where the SS block is not present, may be used instead for transmitting the SS block in time slots where the SS block is being transmitted. This means that the wireless device is not able to receive the DCI in time slots where the SS block is transmitted.

SUMMARY

- 30 The disclosure provides an efficient signaling method that enables a wireless device to receive DCI in time slots where the SS block is transmitted. In exemplary embodiments, the wireless device is configured with two or more control resource sets.

In one exemplary embodiment, the wireless device is configured with or allocated a first control resource set for monitoring in time slots when the SS block is not being transmitted, and a second control resource set to use in time slots where the SS block is transmitted. Because the timing of the SS block is known to the wireless device, the wireless device is able to determine whether the SS block is present in a particular time slot and select either the first control resource set or the second control resource set to monitor for DCI depending on whether the SS block is present or not.

More generally, the wireless device may determine the state of a time slot and select either a first control resource set or a second control resource set to monitor for DCI depending on the state of the time slot. In one exemplary embodiment, the state of the time slot is determined by the presence or absence of the SS block. Those skilled in the art will appreciate, however, that the techniques described herein could be applied to recurring control information other than the SS block.

Another aspect of the disclosure involves an efficient method for signaling the control resource sets. Generally, the cell/base station sends one or more resource identifiers to the wireless device to indicate the first control channel resources, the second control channel resources, or both, to the wireless device. In one exemplary embodiment, the base station explicitly signals the first control resource set to the wireless device. The wireless device then determines the second control resource set based on a pre-determined mapping between the first control resource set and the second control resource set.

Using these techniques, the signaling of the control resource set to be monitored by the wireless device can be made efficient with fewer bits to transmit. Once the control resource set is signaled for a first slot state, a map (for instance defined by standard) may be used to determine the control resource sets to monitor in the other slot states. Thus, there is no need to explicitly signal the control resource set (which typically is a bitmap) for all states.

One aspect of the disclosure comprises methods implemented by a wireless device in a wireless communication network of receiving downlink control information. In one embodiment, the wireless device determines, based on one or more resource identifiers received from a base station, two or more control resource sets to use for receiving downlink control information from the base station. The wireless device further determines a state of a time slot monitored by the wireless device (30, 200, 400) for

downlink control information. The wireless device further monitors for downlink control information in the time slot on one of the control resources sets selected based on the state of the time slot.

Another aspect of the disclosure comprises a wireless device configured to
5 receive downlink control information. In one embodiment, the wireless device comprises an interface circuit for transmitting signals to and receiving signals from a base station in the wireless communication network, and a processing circuit. The processing circuit is configured to synchronize with a cell in the wireless communication network and
10 determine, based on one or more resource identifiers received from a base station, two or more control resource sets to use for receiving downlink control information from the base station. The processing circuit is further configured to determine a state of a time slot monitored by the wireless device for downlink control information, and monitor for
15 downlink control information in the time slot on one of the control resources sets selected based on the state of the time slot.

Another aspect of the disclosure comprises a wireless device configured to
15 synchronize with a cell in the wireless communication network and determine, based on one or more resource identifiers received from a base station, two or more control resource sets to use for receiving downlink control information from the base station. The wireless device is further configured to determine a state of a time slot monitored by
20 the wireless device for downlink control information, and monitor for downlink control information in the time slot on one of the control resources sets selected based on the state of the time slot.

Another aspect of the disclosure comprises a computer program for a wireless
25 device having a processing circuit. The computer program comprises executable instructions that, when executed by the processing circuit in a wireless device of a wireless communication network, causes the wireless device to perform the wireless device methods described above.

Another aspect of the disclosure comprises a carrier containing a computer
30 program as described above, wherein the carrier is one of an electronic signal, optical signal, radio signal, or computer readable storage medium.

Another aspect of the disclosure comprises a non-transitory computer-readable storage medium containing a computer program that, when executed by a processing

circuit in a wireless device in a wireless communication network, causes the wireless device to perform the wireless device methods described above.

Still another aspect of the disclosure comprises methods implemented by a base station in a wireless communication network of transmitting downlink control information.

5 In one embodiment, the base station transmits one or more resource identifiers to a wireless device. The one or more identifiers enable the wireless device to determine the two or more control resource sets to use for receiving the downlink control information. The base station further determines a state of a time slot for transmitting downlink control information to the wireless device, and transmits the downlink control information
10 in the time slot on one of the control resource sets depending on the state of the time slot.

Another aspect of the disclosure comprises a base station configured to transmit downlink control information. In one embodiment, the base station comprises an interface circuit for transmitting signals to and receiving signals from wireless devices in
15 the wireless communication network, and a processing circuit. The processing circuit is further configured to determine two or more control resource sets to use for transmitting downlink control information to a wireless device in a cell of the base station and to transmit one or more resource identifiers to a wireless device. The one or more identifiers enable the wireless device to determine the two or more control resource sets
20 to use for receiving the downlink control information. The processing circuit is further configured to determine a state of a time slot for transmitting downlink control information to the wireless device, and transmit the downlink control information in the time slot on one of the control resource sets depending on the state of the time slot.

Another aspect of the disclosure comprises a base station configured to transmit
25 downlink control information. The base station is configured to transmit one or more resource identifiers to a wireless device. The one or more identifiers enable the wireless device to determine the two or more control resource sets to use for receiving the downlink control information. The base station is further configured to determine a state of a time slot for transmitting downlink control information to the wireless device, and
30 transmit the downlink control information in the time slot on one of the control resource sets depending on the state of the time slot.

Another aspect of the disclosure comprises a computer program for a base station having a processing circuit. The computer program comprises executable

instructions that, when executed by the processing circuit in the base station of a wireless communication network, causes the base station to perform the base station methods described above.

Another aspect of the disclosure comprises a carrier containing a computer program as described above, wherein the carrier is one of an electronic signal, optical signal, radio signal, or computer readable storage medium.

Another aspect of the disclosure comprises a non-transitory computer-readable storage medium containing a computer program that, when executed by a processing circuit in a base station in a wireless communication network, causes the base station to perform the base station methods described above.

BRIEF DESCRIPTION OF THE DRAWINGS

Figure 1 illustrates communications between a base station and a wireless device in a wireless communication network.

Figure 2 illustrates an exemplary frame structure for downlink transmissions from a base station to a wireless device.

Figure 3 illustrates an exemplary method implemented by a wireless device in a wireless communication network.

Figure 4 illustrates an exemplary method implemented by a wireless device in a wireless communication network.

Figure 5 illustrates a method implemented in a wireless communication network.

Figure 6 illustrates an exemplary wireless device configured to perform the methods as herein described.

Figure 7 illustrates an exemplary base station configured to perform the methods as herein described.

Figure 8 illustrates another embodiment of a wireless device in a wireless communication network.

Figure 9 illustrates another embodiment of a base stations in a wireless communication network.

DETAILED DESCRIPTION

Referring now to the drawings, an exemplary embodiment of the present invention will be described in the context of 5th Generation (5G) and Next Radio (NR) wireless communication networks currently under development by the 3rd Generation Partnership Project (3GPP). Those skilled in the art will appreciate, however, that the methods and apparatus described herein are more generally applicable to wireless communication networks that operate according to other standards, especially wireless communication networks using mixed numerology.

Figure 1 illustrates communications between a base station 20 in a wireless communication network 10 and a wireless device 30. The base station 20 is sometimes referred to in applicable standards as an Evolved Node B (eNB) or 5G Node B (gNB). The wireless device 30, sometimes referred to as a user equipment (UE), may comprise a cellular telephone, smart phone, laptop computer, notebook computer, tablet, machine-to-machine (M2M) communication devices (also referred to as machine-type communication (MTC) devices), or other devices with wireless communication capabilities. As shown in Figure 1, the base station 20 transmits the SS block to the wireless device 30 to enable the wireless device 30 to access the network as hereinafter described. After the wireless device establishes a connection with the base station 20 or cell, the base station 20 transmits DCI to the wireless device 30 on the PDCCH, and user data to the wireless device 30 on the PDSCH.

Similar to Long Term Evolution (LTE), 5G and NR wireless communication networks use Orthogonal Frequency Division Multiplexing (OFDM) in the downlink and OFDM or Discrete Fourier Transform (DFT) spread OFDM in the uplink. The physical resources used for communications may be viewed as a time frequency grid. Generally speaking, the time frequency grid is divided into OFDM symbols in the time domain and subcarriers in the frequency domain. Because 5G and NR networks employ mixed numerology, the duration of the OFDM symbol in the time domain and the subcarrier spacing (SCS) in the frequency domain depend on the numerology. The basic resource used for communication, referred to as a resource element, comprises one OFDM symbol in the time domain and one subcarrier in the frequency domain. In one exemplary numerology, the subcarrier spacing (SCS) is 15 kHz and the symbol duration of an OFDM symbol is 66.67 μ s. In another exemplary numerology, the subcarrier spacing is 30 kHz and the OFDM symbol time is 33.33 μ s.

In 5G and NR systems, data is transmitted to the wireless device 30 over a downlink transport channel known as the Physical Downlink Shared Channel (PDSCH). The PDSCH is a time and frequency multiplexed channel shared by a plurality of wireless devices 30. As shown in Figure 2, the downlink transmissions are organized into subframes. Each subframe is divided into a number of time slots, the number being dependent on the numerology used for the downlink transmission. Each time slot includes a control channel portion (shown in blue) in which a Physical Downlink Control Channel (PDCCH) is transmitted and a data portion (shown in white) in which user data is transmitted. The control region may comprise the first one or two OFDM symbols in the timeslot. For purposes of scheduling users to receive downlink transmissions, the downlink time frequency resources are allocated in units called resource blocks (RBs). Each resource block spans 12 subcarriers (which may be adjacent or distributed across the frequency spectrum).

Within a cell, the base station dynamically schedules downlink transmissions to the wireless devices 30 based on channel state information (CSI) or channel quality information (CQI) reports from the wireless device 30 transmitted on the Physical Uplink Control Channel (PUCCH) or Physical Uplink Shared Channel (PUSCH). Alternatively in TDD operation, it may use channel reciprocity for scheduling decisions. The CSI and/or CQI reports indicate the instantaneous channel condition as seen by the wireless device 30. In each time slot, the base station 20 transmits downlink control information (DCI) identifying the wireless devices 30 that have been scheduled to receive data (hereinafter the scheduled wireless devices 30) in the current time slot, and the resource blocks on which the data is being transmitted to the scheduled wireless devices 30. The DCI is typically transmitted on the PDCCH in the control region of the time slot.

In order to establish a connection with the wireless communication network 10, the wireless device 30 needs to find and acquire synchronization with a cell within the wireless communication network 10, read system parameters from a broadcast channel transmitted by the cell, and perform a random access procedure to establish a connection with the cell. The first of these steps is commonly referred to as a cell search. To assist the wireless device 30 in establishing a connection with the wireless communication network 10, the base station 20 transmits a synchronization signal block (SS) block in predetermined time slots. The SS block comprises a Primary Synchronization Signal (PSS), a Secondary Synchronization Signal (SSS), and the

Physical Broadcast Channel (PBCH). In some embodiments, the SS block may further comprise a Tertiary Synchronizations Signal (TSS). The synchronization signals transmitted in each cell comprise a specific set of sequences that identify the cell. By detecting the synchronization signals, the wireless device 30 can acquire the frame
5 timing of the cell and, by observing which of the multiple sequences the cell is transmitting, the wireless device 30 can identify the cell. Once the wireless device 30 has acquired the frame timing and the cell identity, the wireless device 30 can receive the necessary system information (SI) needed to access the cell. More particularly, the wireless device 30 can read system information in the Master Information Block (MIB)
10 that is transmitted on the PBCH. The MIB may identify additional system information blocks (SIBs) transmitted on the PDSCH that also carry system information needed by the wireless device 30.

The 5G and NR standards specify the time and frequency locations of the SS block. The SS block is not transmitted in every time slot. In time slots where the SS
15 block is transmitted, it may overlap control channel resources that could otherwise be used for transmitting DCI on the PDCCH as seen in Figure 2. That is, some of the control channel resources used for transmitting DCI to the wireless device 30 on the PDCCH in time slots where the SS block is not present, may be used instead for transmitting the SS block in time slots where the SS block is being transmitted. A time
20 slot in which the SS block is not transmitted may be considered to be in a first state, and a time slot in which the SS block is transmitted may be considered to be in a second state.

A wireless device 30 is typically configured with a control resource set (CORSET) to monitor for downlink control information. The control resource set is part of the
25 PDCCH. The control resource set is configured in or allocated to the wireless device 30, for example, during connection establishment or during a handover from one cell to another. In time slots where the SS block is transmitted, the control resource set assigned to a wireless device 30 may not be available for transmitting downlink control information because those resources are being used to transmit the SS block.

30 In exemplary embodiments of the present disclosure, the wireless device 30 is configured with or allocated a second control resource set to use in time slots where the SS block is transmitted. The second control resource set is used in addition to the first control resource set. Because the timing of the SS block is known to the wireless device

30, the wireless device 30 is able to determine whether the SS block is present in a particular time slot and select either the first control resource set or the second control resource set to monitor for DCI depending on whether the SS block is present or not.

More generally, the wireless device 30 may determine the state of a time slot and
5 select either a first control resource set or a second control resource set to monitor for DCI depending on the state of the time slot. In the exemplary embodiment described above, the state of the time slot is determined by the presence or absence of the SS block. Those skilled in the art will appreciate, however, that the techniques described herein could be applied to recurring control information other than the SS block. For
10 example, when the base station 20 operates in an unlicensed spectrum, the base station 20 may signal a set of time slots (sometimes called Discovery Signal Measurement Timing Configuration, or DMTC for short) in which synchronization signal blocks may be transmitted. The wireless device 30 may use this information to determine whether a time slot is in a first state or a second state. In some embodiments, the wireless device
15 30 may consider all slots signaled by the base station 20 to be in the second state, even if the base station 20 only transmits synchronization signals in a subset of the signaled time slots. In this case, the wireless device 30 would monitor the first control resource set in time slots where the synchronization blocks may be transmitted, i.e. the first state, and monitor the second control resource set in time slots where additional SI is
20 transmitted (i.e. the second state).

In another embodiment, the state of the time slot may be determined based on the presence or absence of additional system information transmitted on the PDSCH indicated by the MIB. Time slots where the first control resource set overlaps with additional SI transmitted on the PDSCH may be considered to be in a second state. In
25 this case, the wireless device 30 can monitor the first control resource set in time slots where no additional SI is transmitted, i.e. the first state, and monitor the second control resource set in time slots where additional SI is transmitted, i.e., the second state.

In some embodiment, sidelink device-to-device (D2D) resources transmitted in some time slots may use resources that could otherwise be used for the PDCCH. . In
30 this example, the state of the time slot may be determined based on the presence or absence of sidelink D2D resources in the time slot.

Another aspect of the disclosure comprises an efficient method for signaling the first and second control resource sets (or more) to be used by the wireless device 30.

Generally, the base station 20 sends one or more resource identifiers to the wireless device to indicate the first control channel resources, the second control channel resources, or both to the wireless device 30.

In one exemplary embodiment, the base station 20 explicitly signals the first control resource set to the wireless device 30. The wireless device 30 then determines the second control resource set based on a pre-determined mapping between the first control resource set and the second control resource set. In some embodiments, the second resource set may be signaled implicitly by providing the wireless device 30 with additional information for mapping between the first control resource set and the second control resource set.

The first control resource set may be signaled in any number of ways. In one embodiment, the base station 20 sends the wireless device 30 a bitmap (i.e., resource identifier) indicating the control channel resources, i.e., resource elements, in the first control resource set. The bitmap comprises a series of bits, each corresponding to a resource element or group of resource elements. A bit may be set to a value of "1" to indicate that a resource element or group of resource elements belongs to the first control resource set, and set to a value of "0" to indicate that the resource element or group of resource elements do not belong to the first control resource set.

In other embodiments, the resource identifier may comprise an indication of a frequency range. The frequency range may be indicated by a first frequency/subcarrier and a last frequency/subcarrier in the range. The first resource set in this case comprises the two frequencies/subcarriers signaled by the base station 20 and all frequencies/subcarriers in between.

In other embodiments, the base station 20 and the resource identifier may comprise an index value that maps to the first control resource set. For example, the wireless device 30 may be configured with two or more possible control resource sets, each of which is identified by an index value. The available control resource sets may be stored in a lookup table along with the corresponding index values. The wireless device 30 may then use the index value received from the base station 20 or cell to lookup the first control resource set in the lookup table.

As noted above, the wireless device 30 may be configured to determine the second control resource set based on a pre-determined mapping between the first

control resource set and the second control resource set. The predetermined mapping may be specified by standard, or may be signaled to the wireless device 20, for example, through Layer 1/Layer 2 (L1/L2) signaling, or high layer signaling (e.g., radio resource control (RRC) signaling).

5 In one embodiment, the wireless device 30 may determine the second control resource set by applying a known frequency offset to the first control resource set. The frequency offset may specify a frequency shift that is applied to all control channel resources in the first control resource set. The frequency offset may be specified by a standard, or signaled to the wireless device 20 by the base station 20 in L1/L2 signaling,
10 or by another network node via RRC signaling.

 In some embodiments of the invention, the resource identifiers transmitted by the base station 20 may, in addition to indicating the first control resource set, indicate the second control resource set. For example, the base station 20 may transmit a second
15 bitmap or second frequency range to indicate the second control resource set. An advantage of this approach is that it provides more flexibility to the base station 20 in allocating control channel resources at the expense of higher signaling overhead.

 In another embodiment, the wireless device 30 may be configured with two or more control resource set pairs, each of which is assigned an index value. During connection establishment or handover, for example, the base station 30 may transmit an
20 index value to the wireless device 30 indicating a control resource set pair to use for receiving downlink control information. The control resource set pairs may be stored in a lookup table. Upon receipt of the index value from the base station 20, the wireless device 30 may perform a lookup using the received index value to determine the control resource set pair to use for receiving downlink control information. An advantage of this
25 approach is that it requires only a small amount of signaling overhead to signal the control resource set pair.

 Figure 3 illustrates an exemplary method 100 implemented by a wireless device 30 in one exemplary embodiment. The wireless device 30 initially synchronizes with a cell in the wireless communication network 10 (block 110). The particular method of
30 synchronizing with a cell is not a material aspect of the disclosure. The wireless device 30 may employ conventional techniques as described above to synchronize with the cell.

After synchronizing with the cell, the wireless device 30 determines, based on one or more resource identifiers received from a base station, two or more control resource sets to use for receiving downlink control information from the base station (block 120). The two or more control resource sets may include a first control resource set for receiving downlink control information in a first set of time slots corresponding to a first state, and a second control resource set for receiving downlink control information in a second set of time slots corresponding to a second state. Once the control resource sets are determined, the wireless device 30 determines a state of a time slot to monitor for DCI (block 130). The wireless device 30 then monitors for downlink control information in the time slot on one of the control resources sets selected based on the state of the time slot (block 140).

In one embodiment, the wireless device 30 will monitor either a first control resource set or a second control resource set in the time slot depending on the state of the first time slot. If the time slot is in a first state, the wireless device 30 monitors the first control resource set for DCI (block 140). If the time slot is in a second state, the wireless device 30 monitors the second control resource set for DCI. The second control resource set may contain fewer resources than the first control resource set with a less robust coding or format. In this case, a different resource mapping may be used for the smaller control resource set.

The method shown in Figure 3 is easily extended to more than two states. For example, the wireless device 30 may determine, based on the resource identifiers received from the cell, a third set of control resources to use for receiving downlink control information in a third set of slots corresponding to a third state. If the time slot is in a third state, the wireless device 30 receives the downlink control information on the third control resource set. In some embodiments, the second and third control resource sets for the second and third sets of time slots may be same.

In some embodiments, the resource identifiers received from the cell indicate the first control resource set. The resource identifier may comprise a bitmap indicating control channel resources (i.e., resource elements), an indication of a frequency range, or an index value that maps to the first control resource set.

In some embodiments, the wireless device 30 determines the second control resource set by applying a pre-determined mapping between the control channel resources in the first control resource set and the control channel resources in the

second control resource set. In one exemplary embodiment, the wireless device 30 determines the second control resource set by applying a known frequency offset to the control channel resources in the first control resource set. The frequency offset may be specified by standard and pre-configured in the wireless device 30, or received by the wireless device 30 via L1/L2 signaling or higher layer signaling.

In some embodiments, the resource identifiers received from the cell may provide an explicit indication of the second control resource set. The second control resource set may be signaled in the same manner as the first control resource set. For example, the second resource set may be indicated by a bitmap indicating control channel resources (i.e., resource elements), by a frequency range, or by an index value that maps to the second resource set.

In some embodiments, the wireless device 20 may receive a single resource identifier, such as an index value, that indicates both the first and second control resource sets. For example, the wireless device 20 may be pre-configured with two or more resource set pairs which are stored in a lookup table, each associated with an index value. When the wireless device 30 receives the index value, the wireless device 30 may perform a lookup to determine the control resource set pair to use for receiving downlink control information. It will be readily apparent to those skilled in the art that the index value could also map to a triplet, or larger group of control resource sets.

In some embodiments, the wireless device 20 determines the state of the time slot based on a timing of downlink transmissions from the base station 20. For example, the wireless device 30 may determine the state of the time slot based on a known timing of the SS block or other synchronization signals, system information, or a Discovery Signal Measurement Timing Configuration (DMTC).

In some embodiments, the wireless device determines the state of the time slot based on a timing of a window in which the base station can transmit downlink signal. For example, the wireless device 30 may determine the state of the time slot based on the timing of a window in which the base station 20 can transmit synchronization signals, system information, or a Discovery Signal Measurement Timing Configuration (DMTC).

Figure 4 illustrates an exemplary method 150 implemented by a base station 20 in one exemplary embodiment. The base station 20 two or more control resource sets to use for transmitting downlink control information to a wireless device 30 (block 160). In

one embodiment, the two or more control resource sets include a first control resource set is used to transmit downlink control information in a first set of time slots corresponding to a first state, and the second control resource set is used to transmit downlink control information in a second set of time slots corresponding to a second state. Once the control resource sets are determined, the base station 20 transmits one or more resource identifiers to the wireless device 30 that enable the wireless device 30 to determine the two or more control resource sets to use for receiving the downlink control information (block 170). When the base station 20 schedules the wireless device 30 to receive a downlink transmission, the base station determines the state of the slot used for the downlink transmission (block 180). As described above, the base station 20 will transmit downlink control information, e.g., scheduling grant, in the time slot on one of the control resource sets depending on the state of the time slot (block 190).

In one embodiment, the base station 20 will transmit DCI in the time slot on either a first control resource set or a second control resource set depending on the state of the first time slot. If the time slot is in a first state, the base station 20 transmits the DCI on the first control resource. If the time slot is in a second state, the base station 20 transmits the DCI the second control resource set. The second control resource set may contain fewer resources than the first control resource set with a less robust coding or format.

The method shown in Figure 4 is easily extended to more than two states. For example, the base station 20 may determine a third control resource set to use for transmitting downlink control information in a third set of slots corresponding to a third state. Based on the state of the slot, the base station may transmit downlink control information, e.g., scheduling grant, in selected slot on the first, second or third control resource set depending on the state of the slot (block 190).

In some embodiments, the base station 20 determines the control resource sets based on a control rule. For example, the base station 20 may determine the control resource sets based on one or more of a number of wireless devices camping in a cell served by the base station, a desired bandwidth spread of a control channel, and a level of power consumption.

In some embodiments, the base station 20 determines the control resource sets based on an allowed synchronization frequency for a synchronization signal transmitted by the base station in the second set of time slots.

In some embodiments, the base station 20 determines the control resource sets based on what control channel resources have been allocated for other downlink transmission. For example, the base station 20 may determine the control resource sets based on a previous allocation of control channel resources for transmitting
5 synchronization signals, system information, or the DMTC.

In some embodiments, the resource identifiers transmitted to the wireless device 30 indicate the first control resource set. The resource identifier may comprise a bitmap indicating control channel resources (i.e., resource elements), an indication of a frequency range, or an index value that maps to the first control resource set.

10 In some embodiments, the base station 20 transmits a frequency to the wireless device 30 that is used by the wireless device to identify the second control resource set. In this embodiment, the wireless device 30 determines the second control resource set by applying a known frequency offset to the control channel resources in the first control resource set.

15 In some embodiments, the resource identifiers transmitted to the wireless device 30 may provide an explicit indication of the second control resource set. The second control resource set may be signaled in the same manner as the first control resource set. For example, the second resource set may be indicated by a bitmap indicating control channel resources (i.e., resource elements), by a frequency range, or by an index
20 value that maps to the second resource set.

In some embodiments, the base station 20 may transmit a single resource identifier, such as an index value, that indicates both the first and second control resource sets. The wireless device 30 may be pre-configured with two or more resource set pairs which are stored in a lookup table. When the base station 20 transmits the
25 index value, the wireless device 30 may perform a lookup to determine the control resource set pair to use for receiving downlink control information. It will be readily apparent to those skilled in the art that the index value could also map to a triplet, or larger group of control resource sets.

30 Figure 5 illustrates a method of signaling downlink control information from a base station 20 in a wireless communication network 10 to a wireless device 30 served by the base station 20, the method comprising:

transmitting one or more resource identifiers from the base station (20, 300, 500) to a wireless device (30, 200, 400), said one or more identifiers enabling the wireless device (30, 200, 400) to determine two or more control resource sets to use for receiving the downlink control information in different time slots;

5 transmitting, by the base station (20, 300, 500), downlink control information to the wireless device (30, 200, 400) in one of said control resource sets in a selected time slot depending on a state of the time slot; and

10 monitoring, by the wireless device (30, 200, 400), for downlink control information in the time slot on one of the control resources sets selected based on the state of the time slot.

Figure 6 illustrates the main functional components of wireless device 200 configured to receive DCI as herein described. The wireless device 200 comprises a processing circuit 210, a memory 240, and an interface circuit 250. The processing circuit 210 is configured to synchronize with a cell in the wireless communication network
15 10 and determine, based on one or more resource identifiers received from a base station, two or more control resource sets to use for receiving downlink control information from the base station. The processing circuit 210 is further configured to determine a state of a time slot monitored by the wireless device 200 for downlink control information, and monitor for downlink control information in the time slot on one of the
20 control resources sets selected based on the state of the time slot.

The interface circuit 250 includes a radio frequency (RF) circuit 255 coupled to one or more antennas 260. The RF circuit 255 comprises the radio frequency (RF) components needed for communicating with base stations 20 over a wireless
25 communication channel. Typically, the RF components include a transmitter and receiver adapted for communications according to the 5G or NR standards, or other Radio Access Technology (RAT).

The processing circuit 210 processes the signals transmitted to or received by the wireless device 200 and controls the operation of the wireless device 200. Such processing includes coding and modulation of transmitted signals, and the demodulation
30 and decoding of received signals. The processing circuit 210 may comprise one or more microprocessors, hardware, firmware, or a combination thereof. In one embodiment, the processing circuit 210 may include a synchronization unit 215 to synchronize with a cell,

a resource determining unit 220 to identify the first and second control resource sets as herein described, a state determining unit 225 to determine the state of a time slot, and a DCI receiving unit 230 to select one of the control resource sets and receive DCI transmitted on the PDCCH. The processing circuit 210 is configured to perform the
5 methods and procedures as herein described.

Memory 240 comprises both volatile and non-volatile memory for storing computer program code and data needed by the processing circuit 210 for operation. Memory 240 may comprise any tangible, non-transitory computer-readable storage medium for storing data including electronic, magnetic, optical, electromagnetic, or
10 semiconductor data storage. Memory 240 stores a computer program 245 comprising executable instructions that configure the processing circuit 210 to implement the methods and procedures described herein including methods shown in Figure 3. In general, computer program instructions and configuration information are stored in a non-volatile memory, such as a read only memory (ROM), erasable programmable read
15 only memory (EPROM) or flash memory. Temporary data generated during operation may be stored in a volatile memory, such as a random access memory (RAM). In some embodiments, the computer program 245 for configuring the processing circuit 210 may be stored in a removable memory, such as a portable compact disc, portable digital video disc, or other removable media. The computer program 245 may also be
20 embodied in a carrier such as an electronic signal, optical signal, radio signal, or computer readable storage medium.

Figure 7 illustrates the main functional components of base station 300 configured to receive DCI as herein described. The base station 300 comprises a processing circuit 310, a memory 340, and an interface circuit 350. The processing
25 circuit 310 is configured to transmit one or more resource identifiers to a wireless device. The one or more identifiers enable the wireless device 30 to determine the two or more control resource sets to use for receiving the downlink control information. The processing circuit 310 is further configured to determine a state of a time slot for transmitting downlink control information to the wireless device 30, and transmit the
30 downlink control information in the time slot on one of the control resource sets depending on the state of the time slot.

The interface circuit 350 includes a radio frequency (RF) circuit 355 coupled to one or more antennas 360. The RF circuit 355 comprises the radio frequency (RF)

components needed for communicating with wireless devices 30 over a wireless communication channel. Typically, the RF components include a transmitter and receiver adapted for communications according to the 5G or NR standards, or other Radio Access Technology (RAT).

5 The processing circuit 310 processes the signals transmitted to or received by the base station 300 and controls the operation of the base station 300. Such processing includes coding and modulation of transmitted signals, and the demodulation and decoding of received signals. The processing circuit 310 may comprise one or more microprocessors, hardware, firmware, or a combination thereof. In one embodiment, the
10 processing circuit 310 may include a resource determining unit 315 to determine the control resource sets for a wireless device 30, a resource signaling unit 320 to signal the resource selection the first and second control resource sets as herein described, a state determining unit 325 to determine the state of a time slot, and a DCI transmitting unit 330 to select one of the control resource sets for transmitting DCI on the PDCCH. The
15 processing circuit 310 is configured to perform the methods and procedures as herein described.

 Memory 340 comprises both volatile and non-volatile memory for storing computer program code and data needed by the processing circuit 310 for operation. Memory 340 may comprise any tangible, non-transitory computer-readable storage
20 medium for storing data including electronic, magnetic, optical, electromagnetic, or semiconductor data storage. Memory 340 stores a computer program 345 comprising executable instructions that configure the processing circuit 310 to implement the methods and procedures described herein including methods shown in Figure 4. In general, computer program instructions and configuration information are stored in a
25 non-volatile memory, such as a read only memory (ROM), erasable programmable read only memory (EPROM) or flash memory. Temporary data generated during operation may be stored in a volatile memory, such as a random access memory (RAM). In some embodiments, the computer program 345 for configuring the processing circuit 310 may be stored in a removable memory, such as a portable compact disc, portable digital
30 video disc, or other removable media. The computer program 345 may also be embodied in a carrier such as an electronic signal, optical signal, radio signal, or computer readable storage medium.

Figure 8 illustrates another embodiment of a wireless device denoted generally by the numeral 400. The wireless device 400 is configured to perform the methods 100 and 150 described above and shown in Figures 3 and 5. The wireless device 400 comprises a synchronization unit/module 410, a resource determining unit/module 420, and a state determining unit/module 430. In some embodiments, the wireless device 400 further includes a DCI receiving unit/module 440. The various units/modules 410, 420, 430 and 440 can be implemented by processing circuitry and/or by software code that is executed by a processor or processing circuit. The synchronization unit/module 410 is configured to synchronize with a cell in the wireless communication network. The resource determining unit/module 420 is configured to determine, based on one or more resource identifiers received from a base station, two or more control resource sets to use for receiving downlink control information from the base station. The state determining unit/module 430 is configured to determine a state of a time slot monitored by the wireless device 400 for downlink control information. The DCI receiving unit/module 440, if present, is configured to monitor for downlink control information in the time slot on one of the control resources sets selected based on the state of the time slot. In some embodiments.

Figure 9 illustrates another embodiment of a base station denoted generally by the numeral 500. The base station 500 is configured to perform the methods 125 and 150 described above and shown in Figure 4 and 5. The base station 500 comprises a resource selecting unit/module 510, a resource signaling unit/module 520, a state determining unit/module 530 and a DCI transmitting unit/module 540. The various units/modules 510, 520, 530 and 540 can be implemented by processing circuitry and/or by software code that is executed by a processor or processing circuit. The resource selecting unit/module 510 is configured to determine two or more control resource sets to use for transmitting downlink control information to a wireless device in a cell of the base station. The resource signaling unit/module 520 is configured to transmit one or more resource identifiers to a wireless device. The one or more identifiers enable the wireless device to determine the two or more control resource sets to use for receiving the downlink control information. The state determining unit/module 530 is configured to determine a state of a time slot for transmitting downlink control information to the wireless device. The DCI transmitting unit/module 540 is configured to transmit the downlink control information in the time slot on one of the control resource sets depending on the state of the time slot.

Using methods and apparatus as herein described, the signaling of the control resource set to be monitored by the wireless device can be made efficient with fewer bits to transmit. Once the control resource set is signaled for a first slot state, a map (for instance defined by standard) may be used to determine the control resource sets to
5 monitor in the other slot states. Thus, there is no need to explicitly signal the control resource set (which typically is a bitmap) for all states.

CLAIMS

What is claimed is:

1. A method implemented by a wireless device (30, 200, 400) in a wireless communication network (10) of receiving downlink control information, said method
5 comprising:
 - determining, based on one or more resource identifiers received from a base station (20, 300, 500), two or more control resource sets to use for receiving downlink control information from the base station (20, 300, 500);
 - 10 determining a state of a time slot monitored by the wireless device (30, 200, 400) for downlink control information; and
 - monitoring for downlink control information in the time slot on one of the control resources sets selected based on the state of the time slot.
- 15 2. The method of claim 1 wherein the two or more control resource sets include a first control resource set for receiving downlink control information in a first set of time slots corresponding to a first state, and a second control resource set for receiving downlink control information in a second set of time slots corresponding to a second state.
- 20 3. The method of claim 2 wherein the second control resource set contains fewer resources than the first control resource set with less robust coding or formatting.
4. The method of claims 2 or 3, wherein the two or more control resource
25 sets further include a third control resource set for receiving downlink control information in a third set of time slots corresponding to a third state.
5. The method of any one of claims 1-3, further comprising receiving
30 downlink control information in the time slot on the selected one of the two or more control resource sets.

6. The method of any one of claims 2 - 5, wherein the one or more resource identifiers comprise at least one of:

- a first frequency range for the first control resource set;
- 5 a first bitmap identifying the first control resource set; and
- a first index value associated with the first resource control set.

7. The method of any one of claims 2-5, wherein determining the second control resource set comprises applying a predetermined mapping between control
10 resources in the first control resource set and control channel resources in the second control resource set.

8. The method of any one of claims 2-5, wherein the one or more resource identifiers comprises a frequency offset, and wherein determining the second control
15 resource set is determined based on the frequency offset and the first control resource set.

9. The method of any one of claims 2-5, wherein the one or more resource identifiers comprises at least one of:
20 a second frequency range for the second control resource set;
a second bitmap identifying the second control resource set, and wherein the second control resource set is determined based on the second bitmap;
and
a second index value, and wherein the second control resource set is determined
25 based on the second index value.

10. The method of any one of claims 2-5, wherein the one or more resource identifiers comprise a single index value associated with a control resource set pair, and

wherein the first and second control resource sets are determined based on the single index value.

11. The method of any one of claims 2-10, wherein the second set of time
5 slots comprises time slots used for transmitting at least one of:

a synchronization signal that overlaps with the first control resource set;

a synchronization signal block that overlaps with the first control resource set;

and

system information that overlaps with the first control resource set.

10

12. The method of any one of claims 1-11, wherein determining the state of a
time slot monitored by the wireless device (30, 200, 400) comprises at least one of:

determining whether a synchronization signal is transmitted in the time slot;

determining whether a synchronization signal block is transmitted in the time slot;

15

and

determining whether system information is transmitted in the time slot.

13. The method of any one of claims 1-11, wherein determining the state of a
time slot monitored by the wireless device (30, 200, 400) comprises determining whether
20 the time slot falls within the window in which the cell can transmit at least one of
synchronization signals, a synchronization signal block, or system information.

14. The method of claim 13, wherein the window comprises a Discovery
Signal Measurement Timing Configuration (DMTC).

25

15. A wireless device (30, 200, 400) in a wireless communication network
(10) configured to:

synchronize with a cell in the wireless communication network (10);

determine, based on one or more resource identifiers received from the cell, two or more control resource sets to use for receiving downlink control information from a base station (20, 300, 500);

determine a state of a time slot; and

5 monitor for downlink control information in the time slot on one of the control resources sets selected based on the state of the time slot.

16. The wireless device (30, 200, 400) of claim 15 configured to perform the method of any one of claims 2-14.

10

17. A computer program (245) comprising executable instructions that, when executed by a processing circuit (210) in a wireless device (200) of a wireless communication network (10), causes the wireless device (200) to perform any one of the methods of claims 1-14.

15

18. A carrier containing a computer program of claim 17, wherein the carrier is one of an electronic signal, optical signal, radio signal, or computer readable storage medium.

20

19. A non-transitory computer-readable storage medium (240) containing a computer program (245) comprising executable instructions that, when executed by a processing circuit (210) in a wireless device (200) in a wireless communication network (10) causes the wireless device (200) to perform any one of the methods of claims 1-14.

25

20. A method implemented by a base station (20, 300, 500) in a wireless communication network (10) of transmitting downlink control information, said method comprising:

determining two or more control resource sets to use for transmitting downlink control information to a wireless device (30, 200, 400);

transmitting one or more resource identifiers to a wireless device (30, 200, 400),
said one or more identifiers enabling the wireless device (30, 200, 400) to
determine the two or more control resource sets to use for receiving the
downlink control information;

5 determining a state of a time slot for transmitting downlink control information to
the wireless device (30, 200, 400); and
transmitting the downlink control information in the time slot on one of the control
resource sets depending on the state of the time slot.

10 21. The method of claim 20 wherein the two or more control resource sets
include a first control resource set for transmitting downlink control information in a first
set of time slots corresponding to a first state, and a second control resource set for
transmitting downlink control information in a second set of time slots corresponding to a
second state.

15 22. The method of claim 21 wherein the second control resource set contains
fewer resources than the first control resource set with less robust coding or formatting.

20 23. The method of claims 21 or 22, wherein the two or more control resource
sets further include a third control resource set for transmitting downlink control
information in a third set of time slots corresponding to a third state.

24. The method of any one of claims 21-23, wherein the first and second
control resource sets are determined based on at least one of:
25 a number of wireless devices (30, 200, 400) in a cell served by the base station
(20, 300, 500);
a desired bandwidth spread of a control channel; and
a level of power consumption.

25. The method of any one of claims 20-24, further comprising:
determining an allowed synchronization frequency for a synchronization signal transmitted by the base station (20, 300, 500) in the second set of time slots; and
5 determining the second control resource set based on the allowed synchronization frequency.
26. The method of any one of claims 20-24, further comprising:
allocating control channel resources for a downlink transmission, in the second
10 set of time slots, of at least one of system information, synchronization signals, and a Discovery Signal Measurement Timing Configuration (DMTC) ; and
determining the second control resource set based on the control channel resources allocated for transmitting the system information,
15 synchronization signals and/or Discovery Signal Measurement Timing Configuration (DMTC).
27. The method of any one of claims 20-26, wherein the one or more resource identifiers comprise at least one of:
20 a first frequency range for the first control resource set;
a first bitmap identifying the first control resource set; and
a first index value associated with the first control resource set.
28. The method of any one of claims 20-26, wherein the one or more
25 resource identifiers comprises a frequency offset used by the wireless device (30, 200, 400) to determine the second control resource set.
29. The method of any one of claims 20-26, wherein the one or more resource identifiers comprises at least one of:

a second frequency range for the second control resource set.

a second bitmap identifying the second control resource set.

a second index value associated with the second control resource set.

5 30. The method of any one of claims 20-26, wherein the one or more resource identifiers comprises a single index associated with a control resource set pair.

10 31. The method of any one of claims 20-30, wherein the second set of time slots comprises time slots used for transmitting signals that overlap with the first control resource set, wherein said signals comprise at least one of:

a synchronization signal block that overlaps with the first control resource set;

system information that overlaps with the first control resource set; and

a Discovery Signal Measurement Timing Configuration (DMTC) that overlaps with the first control resource set.

15

20 32. The method of any one of claims of any one of claims 20-31, wherein determining a state of a time slot for transmitting downlink control information to the wireless device (30, 200, 400) comprises determining the state of the time slot based on whether at least one of a synchronization signal, a synchronization signal block, and system information is transmitted in the time slot.

25 33. The method of any one of claims 20-31, wherein determining a state of a time slot for transmitting downlink control information to the wireless device (30, 200, 400) comprises determining if the time slot falls within a window where the base station (20, 300, 500) can transmit at least one of a synchronization signal; system information, and a Discovery Signal Measurement Timing Configuration (DMTC).

34. A base station (20, 300, 500) in a wireless communication network (10) configured to:

determine two or more control resource sets to use for transmitting downlink control information to a wireless device (30, 200, 400) in a cell of the base station (20, 300, 500);

5 transmit one or more resource identifiers to a wireless device (30, 200, 400), said one or more identifiers enabling the wireless device (30, 200, 400) to determine the two or more control resource sets to use for receiving the downlink control information;

determine a state of a time slot for transmitting downlink control information to the wireless device (30, 200, 400); and

10 transmit the downlink control information in the time slot on one of the control resource sets depending on the state of the time slot.

35. The base station (20, 300, 500) of claim 24 configured to perform the method of any one of claims 21-33.

15

36. A computer program comprising executable instructions that, when executed by a processing circuit (310) in a base station (300) of a wireless communication network (10), causes the base station (300) to perform any one of the methods of claims 20-33.

20

37. A carrier containing a computer program (345) of claim 36, wherein the carrier is one of an electronic signal, optical signal, radio signal, or computer readable storage medium.

25

38. A non-transitory computer-readable storage medium containing a computer program (345) comprising executable instructions that, when executed by a processing circuit (310) in a base station (300) of a wireless communication network (10) causes the base station (300) to perform any one of the methods of claims 20-33.

30

39. A method of signaling downlink control information from a base station (20, 300, 500) in a wireless communication network (10) to a wireless device (30, 200, 400) served by the base station (20, 300, 500), the method comprising:

5 transmitting one or more resource identifiers from the base station (20, 300, 500) to a wireless device (30, 200, 400), said one or more identifiers enabling the wireless device (30, 200, 400) to determine two or more control resource sets to use for receiving the downlink control information in different time slots;

10 transmitting, by the base station (20, 300, 500), downlink control information to the wireless device (30, 200, 400) in one of said control resource sets in a selected time slot depending on a state of the time slot; and

monitoring, by the wireless device (30, 200, 400), for downlink control information in the time slot on one of the control resources sets selected based on the state of the time slot.

15

40. A wireless communication network (10) comprising:

a base station (20, 300, 500) configured to:

20 transmit one or more resource identifiers to a wireless device (30, 200, 400), said one or more identifiers enabling the wireless device (30, 200, 400) to determine two or more control resource sets to use for receiving the downlink control information in different time slots;

transmit downlink control information to the wireless device (30, 200, 400) in one of said control resource sets in a selected time slot depending on a state of the time slot; and

25 a wireless device (30, 200, 400) configured to monitor for downlink control information in the time slot on one of the control resources sets selected based on the state of the time slot.

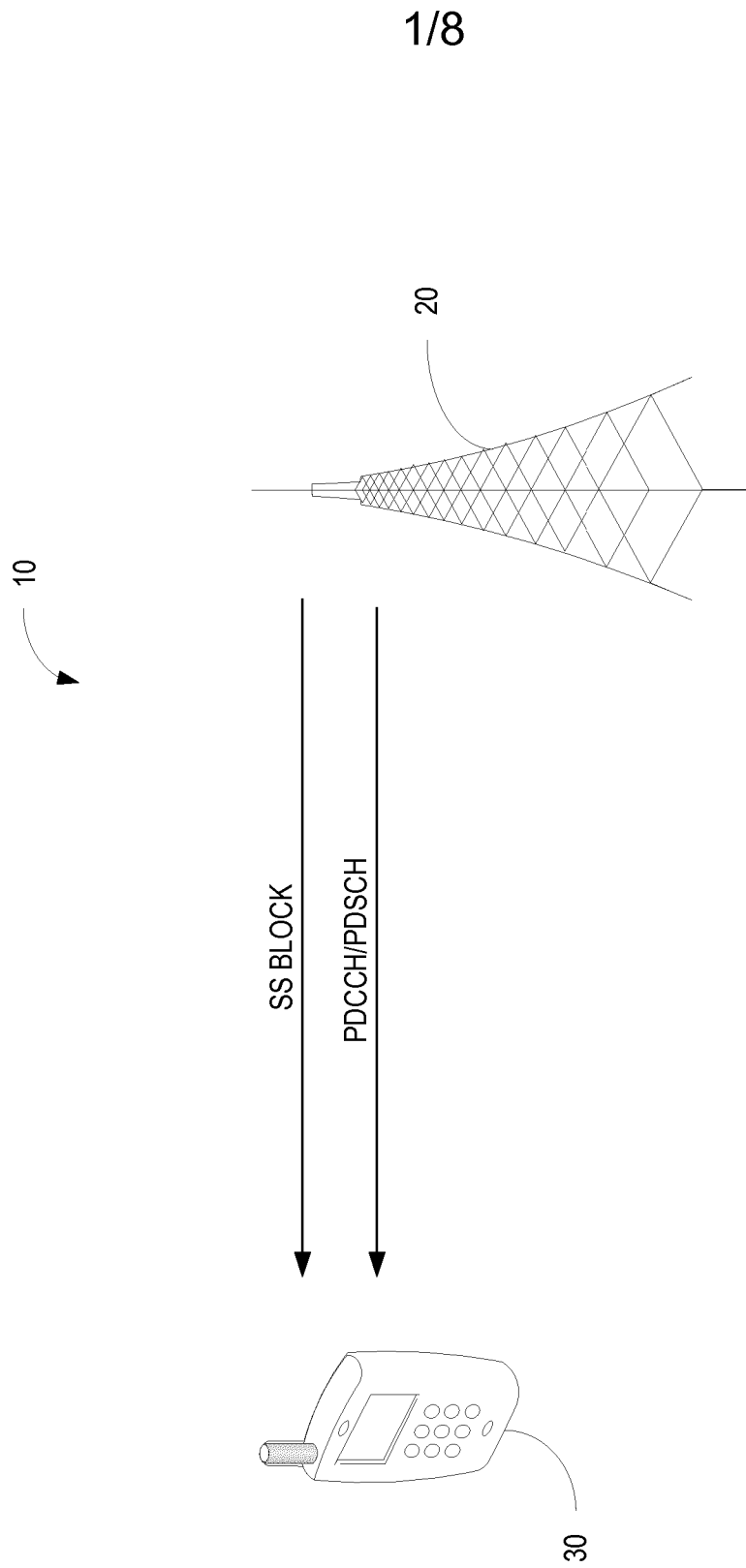

FIG. 1

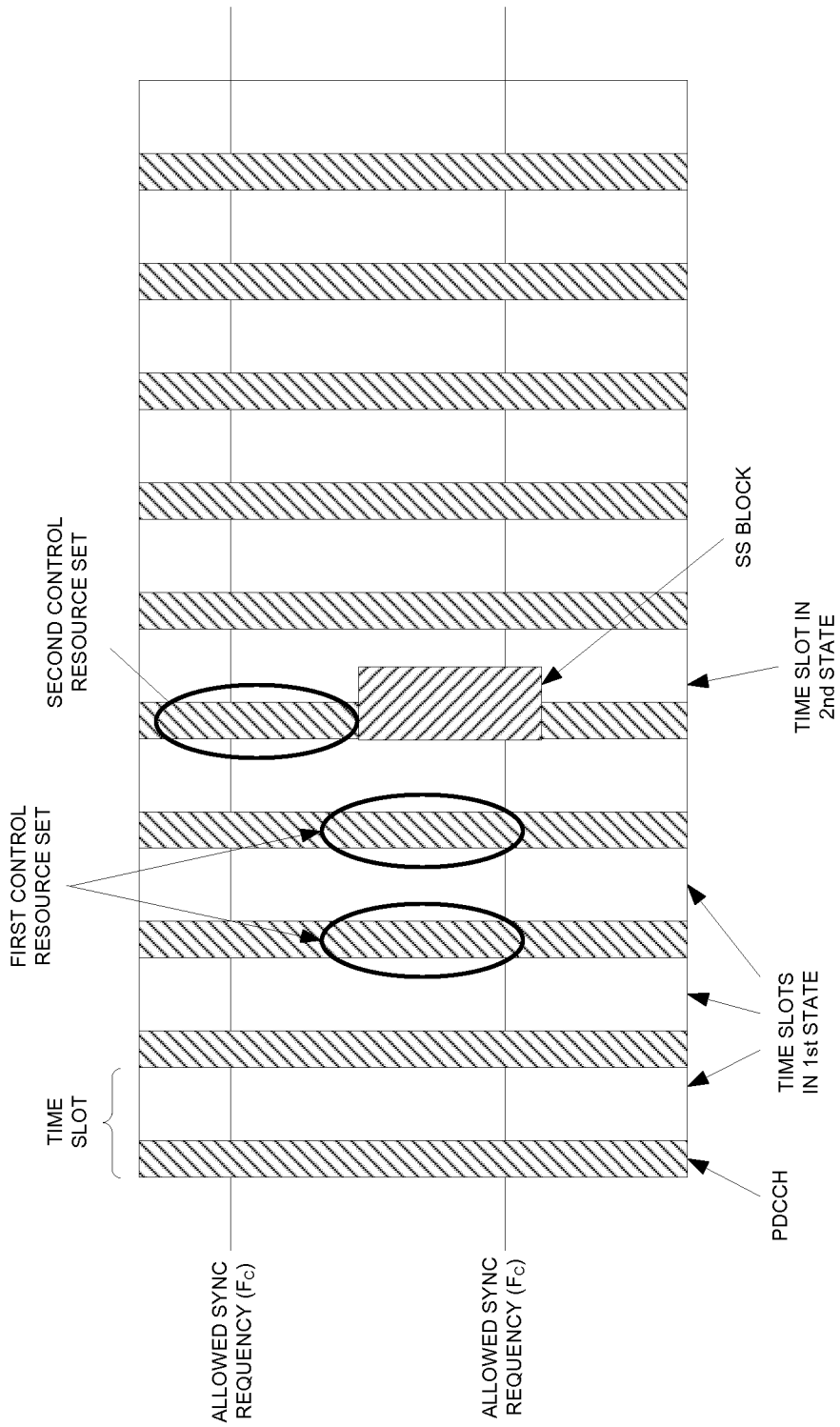
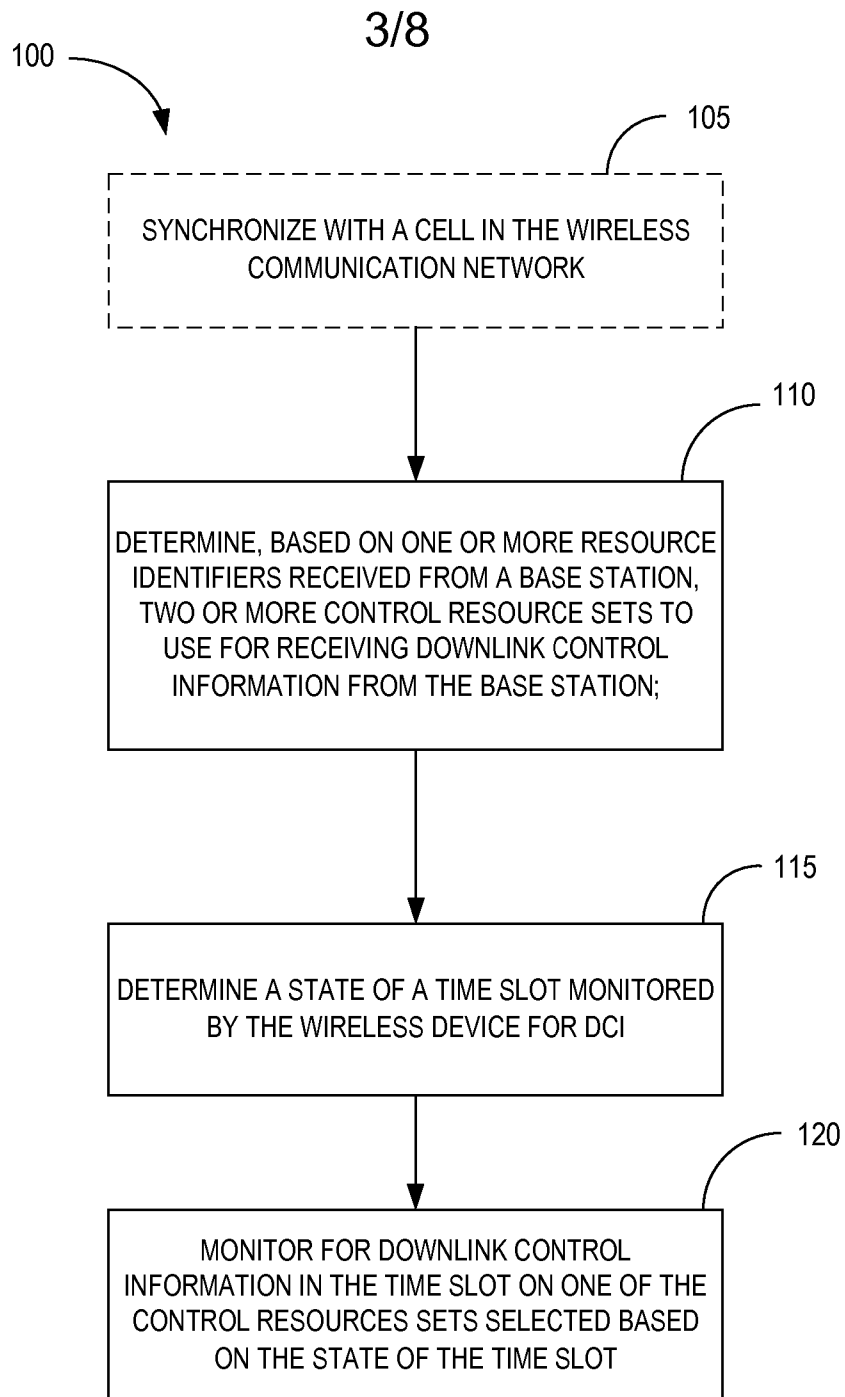
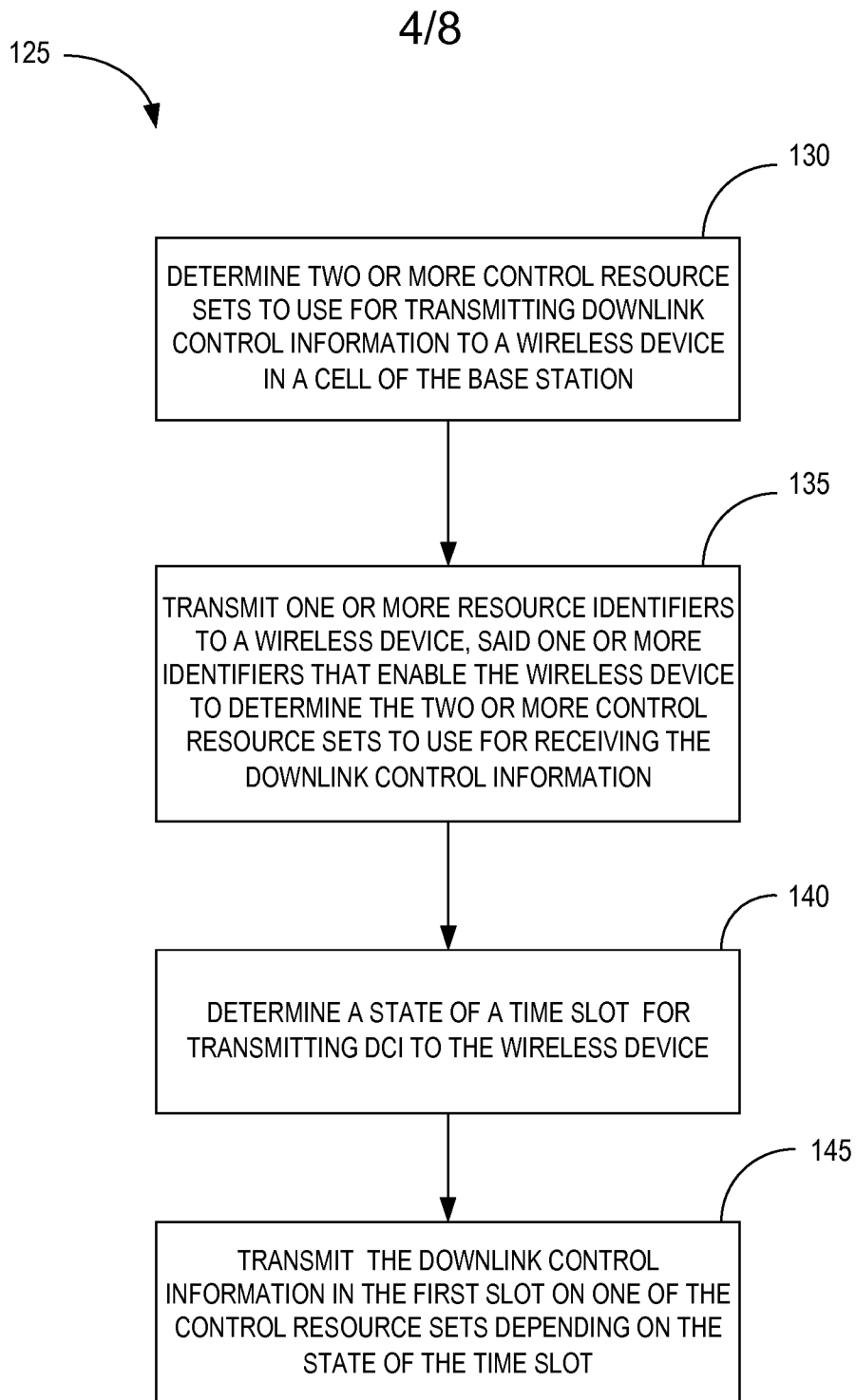
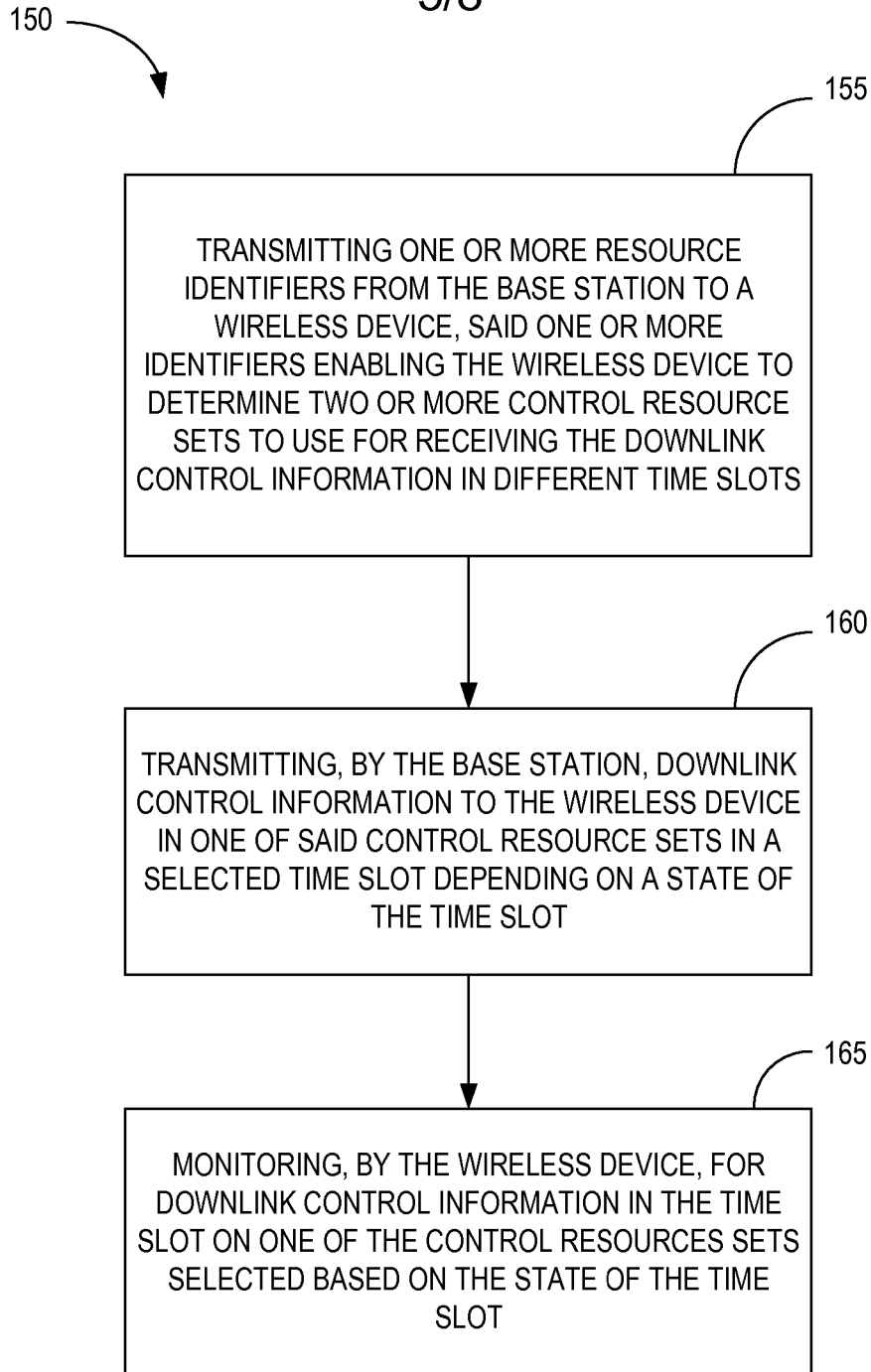

FIG. 2

**FIG. 3**

**FIG. 4**

5/8

**FIG. 5**

6/8

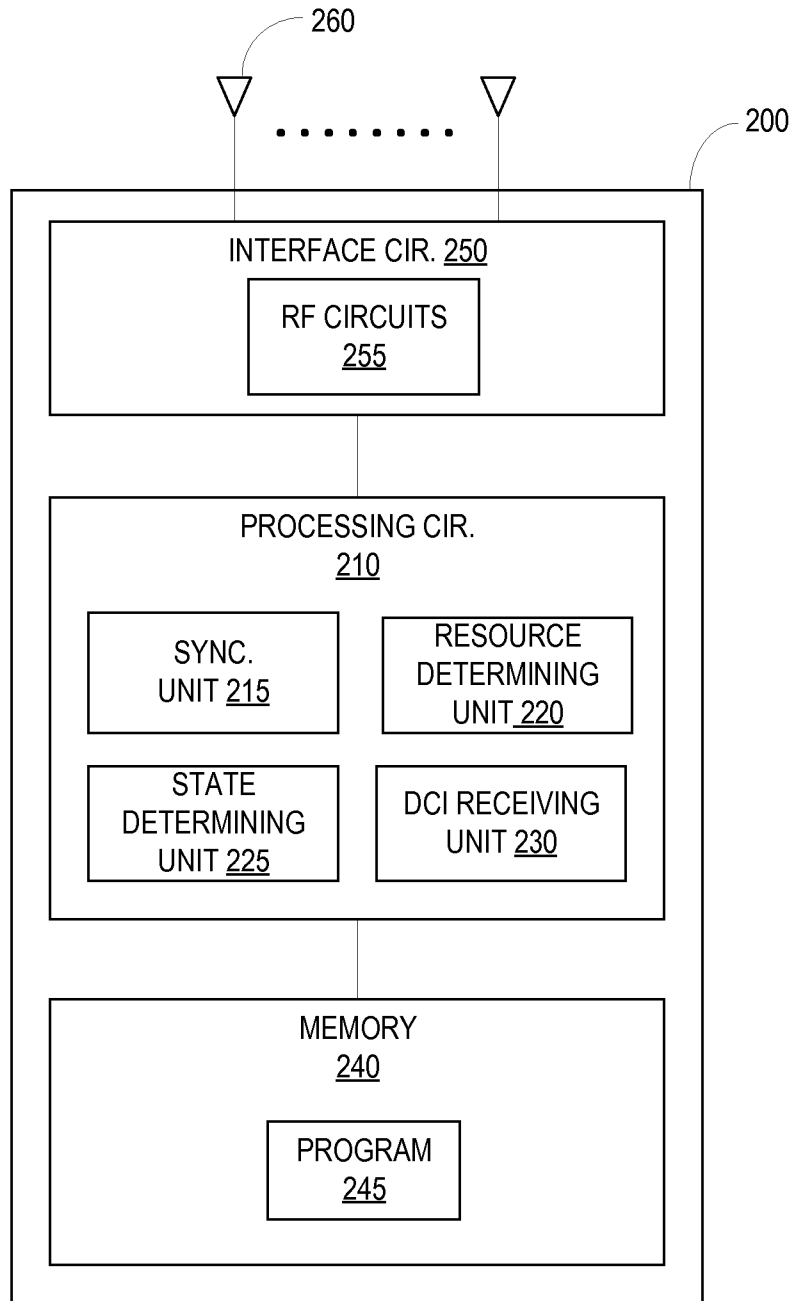

FIG. 6

7/8

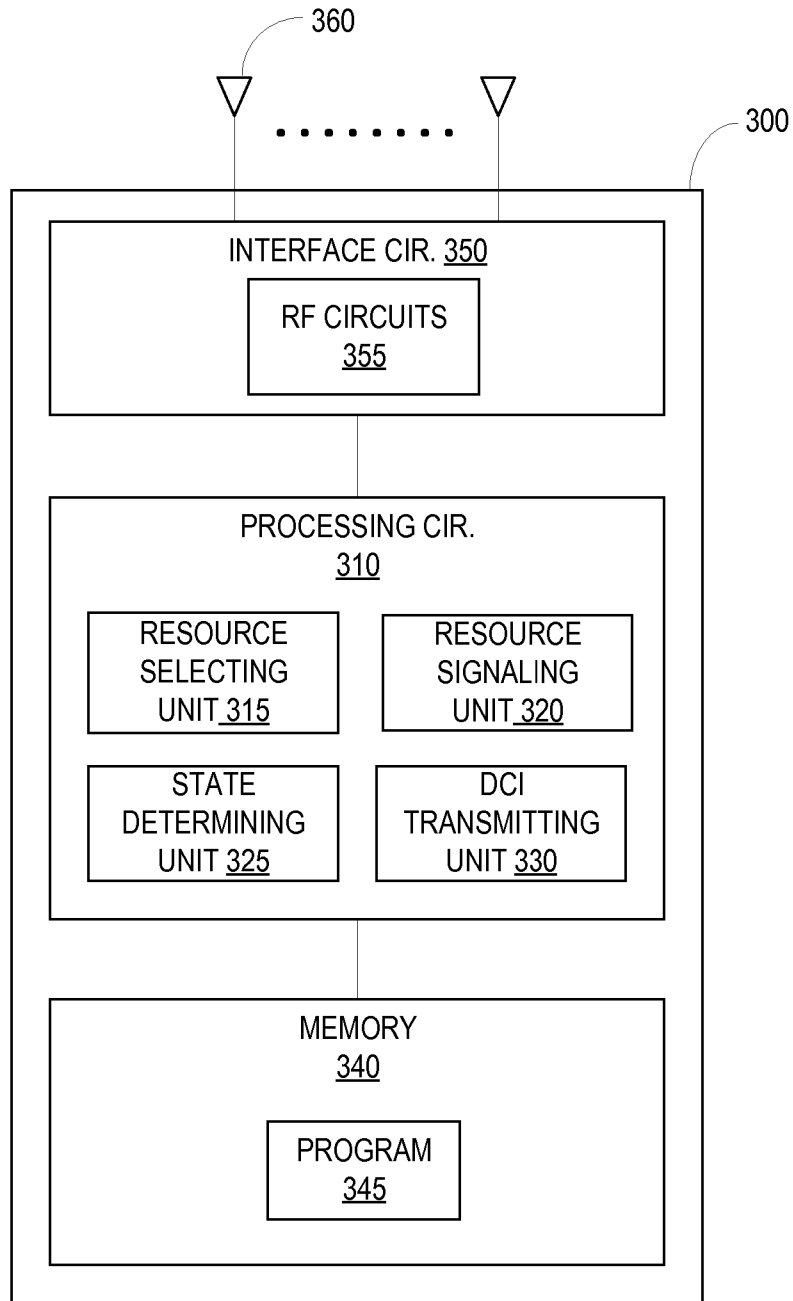

FIG. 7

8/8

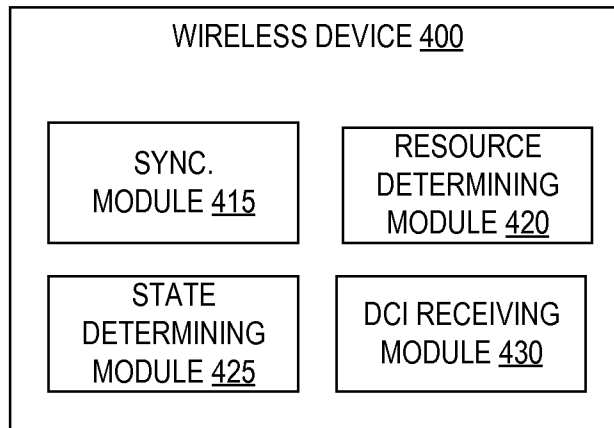

FIG. 8

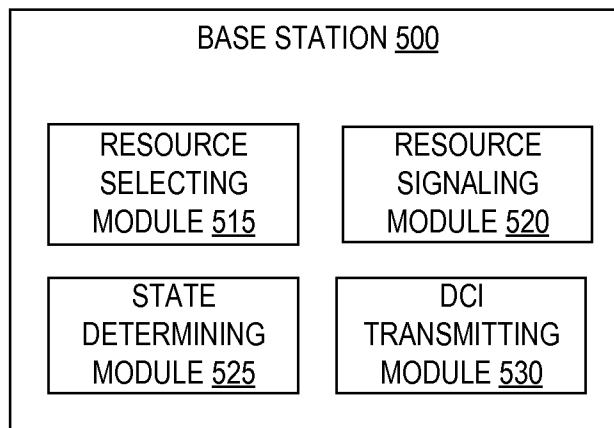

FIG. 9

INTERNATIONAL SEARCH REPORT

International application No
PCT/EP2018/057528

A. CLASSIFICATION OF SUBJECT MATTER
INV. H04W72/12
ADD. H04W72/04

According to International Patent Classification (IPC) or to both national classification and IPC

B. FIELDS SEARCHED

Minimum documentation searched (classification system followed by classification symbols)
H04W

Documentation searched other than minimum documentation to the extent that such documents are included in the fields searched

Electronic data base consulted during the international search (name of data base and, where practicable, search terms used)
EPO-Internal, WPI Data

C. DOCUMENTS CONSIDERED TO BE RELEVANT		
Category*	Citation of document, with indication, where appropriate, of the relevant passages	Relevant to claim No.
X	US 2016/029239 A1 (SADEGHI POURIYA [US] ET AL) 28 January 2016 (2016-01-28) paragraph [0133] - paragraph [0135] paragraph [0136] - paragraph [0137] paragraph [0138] - paragraph [0139] -----	1-40
X	EP 2 894 915 A1 (HUAWEI TECH CO LTD [CN]) 15 July 2015 (2015-07-15) paragraph [0021] - paragraph [0024]; figures 3, 4a paragraph [0025] - paragraph [0029]; figures 4b, 5 paragraph [0030] - paragraph [0035]; figures 6, 7 paragraph [0067] - paragraph [0073] paragraph [0074] - paragraph [0080] paragraph [0081] - paragraph [0088] paragraph [0089] - paragraph [0096] ----- -/--	1-40

Further documents are listed in the continuation of Box C.

See patent family annex.

* Special categories of cited documents :

"A" document defining the general state of the art which is not considered to be of particular relevance

"E" earlier application or patent but published on or after the international filing date

"L" document which may throw doubts on priority claim(s) or which is cited to establish the publication date of another citation or other special reason (as specified)

"O" document referring to an oral disclosure, use, exhibition or other means

"P" document published prior to the international filing date but later than the priority date claimed

"T" later document published after the international filing date or priority date and not in conflict with the application but cited to understand the principle or theory underlying the invention

"X" document of particular relevance; the claimed invention cannot be considered novel or cannot be considered to involve an inventive step when the document is taken alone

"Y" document of particular relevance; the claimed invention cannot be considered to involve an inventive step when the document is combined with one or more other such documents, such combination being obvious to a person skilled in the art

"&" document member of the same patent family

Date of the actual completion of the international search 20 June 2018	Date of mailing of the international search report 29/06/2018
---	--

Name and mailing address of the ISA/ European Patent Office, P.B. 5818 Patentlaan 2 NL - 2280 HV Rijswijk Tel. (+31-70) 340-2040, Fax: (+31-70) 340-3016	Authorized officer Puiulet, Alexandru
--	--

INTERNATIONAL SEARCH REPORT

International application No
PCT/EP2018/057528

C(Continuation). DOCUMENTS CONSIDERED TO BE RELEVANT		
Category*	Citation of document, with indication, where appropriate, of the relevant passages	Relevant to claim No.
X	<p>NTT DOCOMO ET AL: "Resource sharing between data and control channels", 3GPP DRAFT; R1-1705747, 3RD GENERATION PARTNERSHIP PROJECT (3GPP), MOBILE COMPETENCE CENTRE ; 650, ROUTE DES LUCIOLES ; F-06921 SOPHIA-ANTIPOLIS CEDEX ; FRANCE</p> <p>, vol. RAN WG1, no. Spokane, USA; 20170403 - 20170407 2 April 2017 (2017-04-02), XP051243862, Retrieved from the Internet: URL:http://www.3gpp.org/ftp/Meetings_3GPP_SYNC/RAN1/Docs/ [retrieved on 2017-04-02] section "2.1. Slot-level data scheduling"; section "2.2. Mini-slot-level data scheduling"; figures 1-5 section "3. Conclusion". -----</p>	1-40

INTERNATIONAL SEARCH REPORT

Information on patent family members

International application No

PCT/EP2018/057528

Patent document cited in search report	Publication date	Patent family member(s)	Publication date	
US 2016029239	A1	28-01-2016	CN 105191445 A	23-12-2015
			EP 2982194 A1	10-02-2016
			JP 6244009 B2	06-12-2017
			JP 2016519507 A	30-06-2016
			KR 20150138365 A	09-12-2015
			TW 201446046 A	01-12-2014
			US 2016029239 A1	28-01-2016
			WO 2014165510 A1	09-10-2014

EP 2894915	A1	15-07-2015	BR 112015006774 A2	04-07-2017
			CA 2886245 A1	03-04-2014
			CN 103907386 A	02-07-2014
			EP 2894915 A1	15-07-2015
			KR 20150063118 A	08-06-2015
			MX 345323 B	25-01-2017
			US 2015200741 A1	16-07-2015
			WO 2014047821 A1	03-04-2014
			ZA 201502317 B	26-10-2016
