

Nov. 20, 1934.

S. J. HEINER

1,981,104

JAR OPENER AND CLOSER

Filed April 23, 1934

3 Sheets-Sheet 1

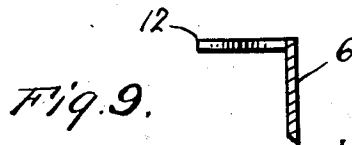
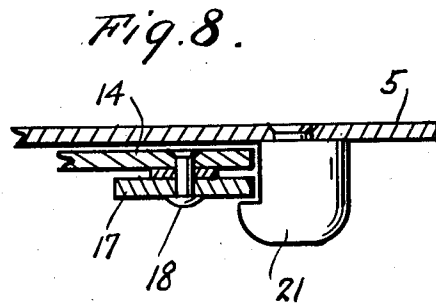
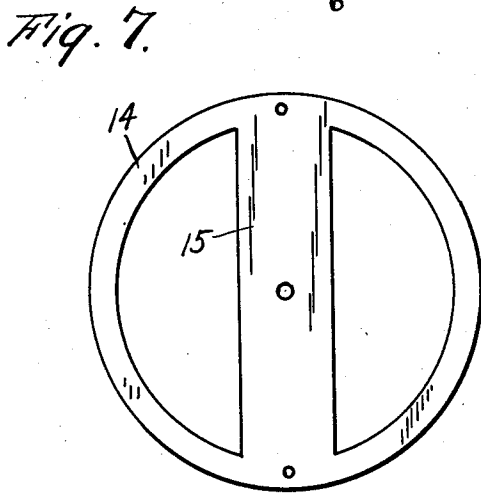
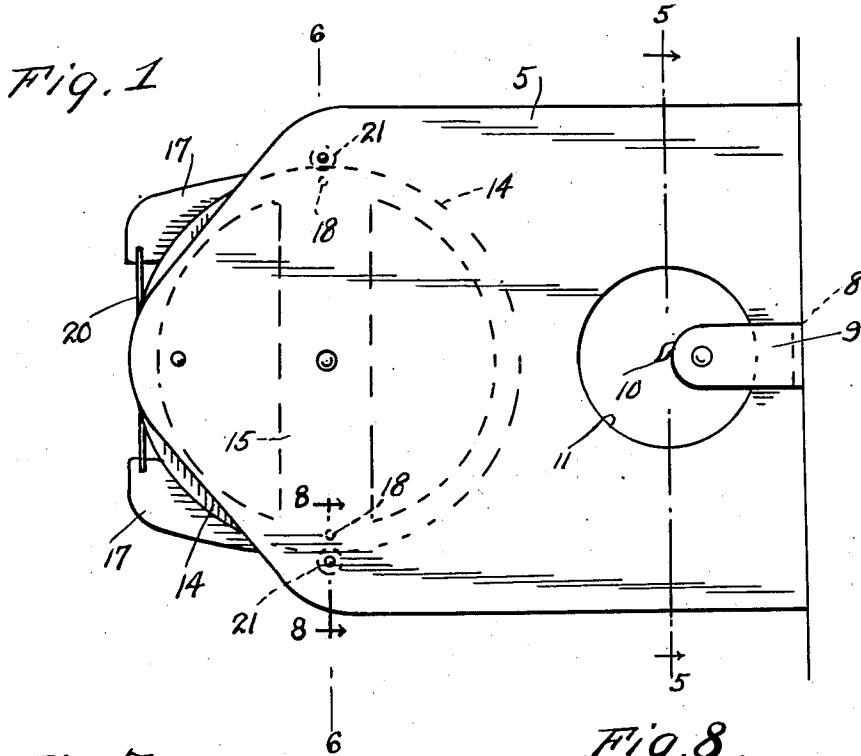

Inventor

S. J. Heiner

By *Alvanor A. O'Brien*
Attorney

Nov. 20, 1934.

S. J. HEINER

1,981,104

JAR OPENER AND CLOSER

Filed April 23, 1934

3 Sheets-Sheet 2

Fig. 2.

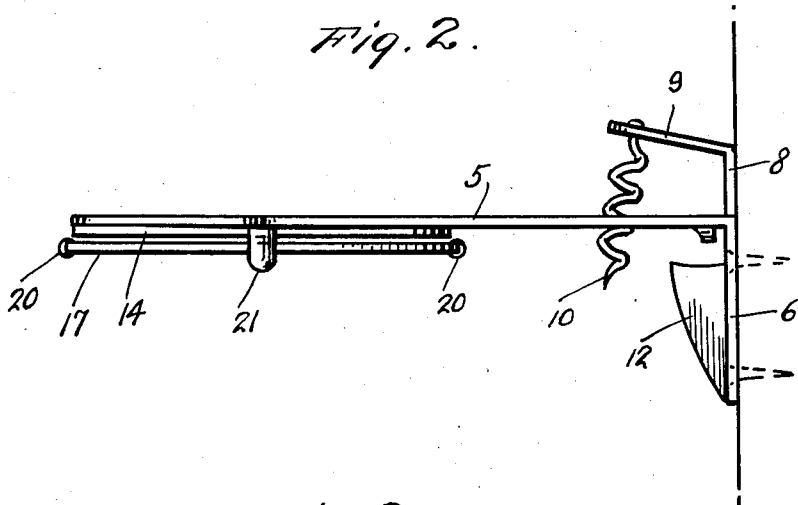
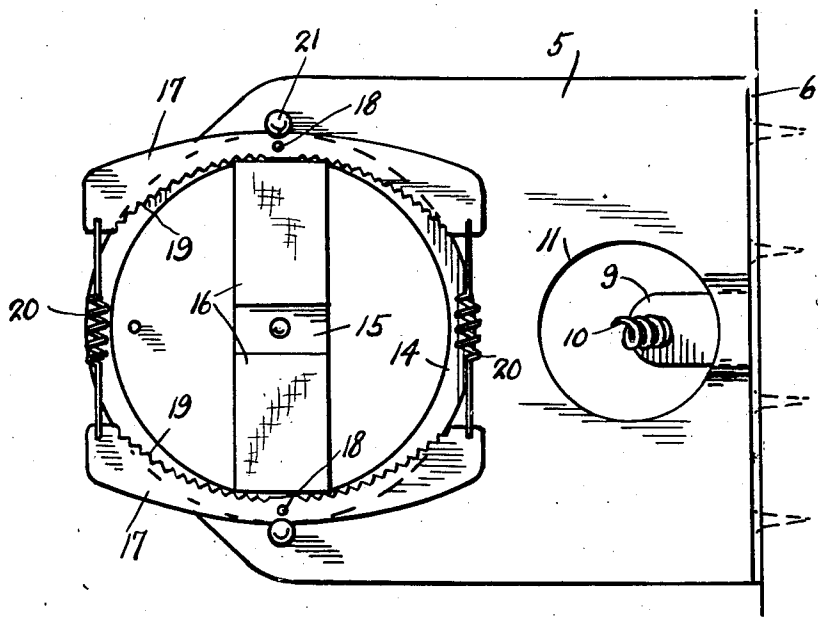

Fig. 3.



Inventor

S. J. Heiner

By *Alvanee O'Brien*
Attorney

Nov. 20, 1934.

S. J. HEINER

1,981,104

JAR OPENER AND CLOSER

Filed April 23, 1934

3 Sheets-Sheet 3

Fig. 4.

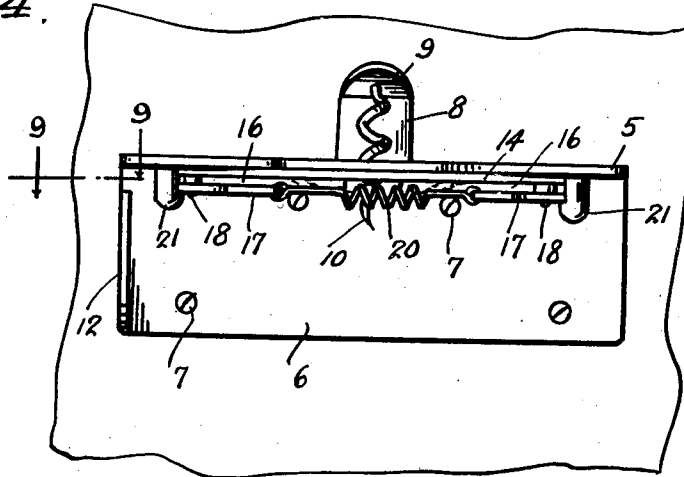

Fig. 5.

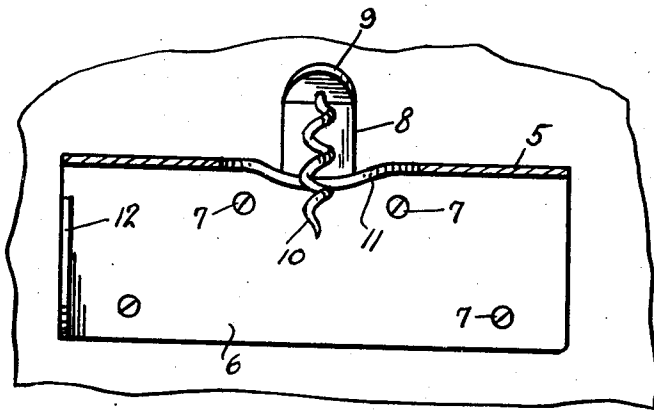
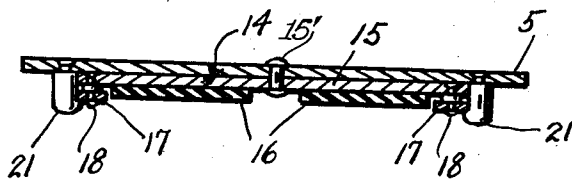

Fig. 6.



Inventor

S. J. Heiner

By *Clarence A. O'Brien*
Attorney

UNITED STATES PATENT OFFICE

1,981,104

JAR OPENER AND CLOSER

Stephen J. Heiner, Scranton, Pa.

Application April 23, 1934, Serial No. 722,027

3 Claims. (Cl. 81—3.3)

The present invention relates to a combination device embodying the features of a jar opener and closer, a cap remover and cork puller.

An important object of the invention resides in the provision of a device of this nature which is simple in its construction, inexpensive to manufacture, easy to manipulate, thoroughly efficient and reliable in use, compact and convenient in its arrangement of parts and otherwise well adapted to the purpose for which it is designed.

With the above and numerous other objects in view as will appear as the description proceeds, the invention consists in certain novel features of construction, and in the combination and arrangement of parts as will hereinafter be more fully described and claimed.

In the drawings:

Figure 1 is a top plan view of the device embodying the features of my invention.

Figure 2 is a side elevation thereof.

Figure 3 is a bottom plan view thereof.

Figure 4 is an end elevation thereof.

Figure 5 is a sectional view taken substantially on the line 5—5 of Figure 1.

Figure 6 is a sectional view taken substantially on the line 6—6 of Figure 1.

Figure 7 is a plan view of a ring.

Figure 8 is an enlarged detail section taken substantially on the line 8—8 of Figure 1, and

Figure 9 is a detail section taken substantially on the line 9—9 of Figure 4.

Referring to the drawings in detail it will be seen that the numeral 5 denotes a plate having at one end a depending flange 6 adapted to be secured to a wall or other support by screws 7 or other fastening elements. Rising from the plate 5 adjacent the flange 6 is an arm 8 with a forward extension 9 from which depends a corkscrew 10 which protrudes through an opening 11 in the plate. On the flange 6 at one end thereof is a bottle opener or cap remover 12.

Under the other end portion of the plate 5 there is pivoted a ring 14 having a cross member 15 therein on which is fixed a pair of rubber pads 16. The pivot pin 15' of the ring passes through the central portion of the cross member 15 into the plate 5 as shown more particularly in Figure 6. A pair of jaws 17 are of arcuate construction and are pivoted at their centers as at 18 to the ring 14. Teeth 19 are provided on the inner edges of these jaws. The curvature of the jaws is on a larger radius than the curvature of the ring 14. Springs 20 connect the ends of the two jaws. A pair of lugs 21 depend from the plate 5 alongside of the central portion of the jaws and

underhang said central portion as clearly illustrated in Figure 8.

When a cap is to be removed from a jar the cap of the jar is placed against the pads 16 and the jar, being held by both hands, is pressed upwardly toward the cap to frictionally engage the pads. Then the jar is given a rotary movement and this results in a rotary movement of the ring 14 and the jaws, due to the frictional engagement of the jar cap with the pads and this turning movement of the ring 14 and the jaws will cause the lugs 21 to tilt the jaws so that opposite ends thereof will grip the cap, so that a further turning movement of the jar will cause the jaws to unscrew the cap from the jar. When a cap is to be placed on a jar it is partly threaded on the jar and then the jar with the cap thereon is placed in position with the cap engaging the pads and when the jar is given a rotary movement in an opposite direction from that used to unscrew the cap this will cause the jaws to grip the cap and hold it while the jar is being turned to tightly place the cap on the jar. The springs 20 act to hold the jaws in initial position as shown in Figure 3.

It is thought that the construction, operation, utility and advantages of this invention will now be quite apparent to those skilled in this art without a more detailed description thereof.

The present embodiment of the invention has been described in considerable detail merely for the purposes of exemplification since in actual practice it attains the features of advantage enumerated as desirable in the statement of the invention and the above description.

It will be apparent that changes in the details of construction, and in the combination and arrangement of parts may be resorted to without departing from the spirit or scope of the invention as hereinafter claimed or sacrificing any of its advantages.

Having thus described my invention, what I claim as new is:

1. A device of the class described comprising a plate, a pair of curved jaws pivoted under the plate in spaced relation to each other, and springs connecting the ends of said jaws, a ring interposed between the jaws and the plate and having a cross member with a pair of pads thereon.

2. A device of the class described comprising a supporting member, a rotary member pivoted thereto, a pair of curved jaws pivoted at their centers to the rotary member and lugs carried by the supporting member and engaging the central portion of the outer edges of the jaws, whereby

turning movement of the rotary member will cause the lugs to tilt the jaws.

3. A device of the class described comprising a supporting member, a rotary member pivoted thereto, a pair of oppositely arranged arcuate jaws pivoted at their centers to the rotary member, each jaw having teeth on its inner concaved edge, springs connecting the ends of the jaws to-

gether, a pair of lugs carried by the supporting member and contacting the central portions of the outer edges of the jaws for tilting the jaws when the rotary member is rotated and a pad carried by the rotary member for engagement by an article pressed against the same and adapted to be gripped by the jaws. 80

STEPHEN J. HEINER.

10

85

15

90

20

95

25

100

30

105

35

110

40

115

45

120

50

125

55

130

60

135

65

140

70

145

75

150