

(No Model.)

M. B. MONROE.
EXTENSION LADDER.

No. 524,784.

Patented Aug. 21, 1894.

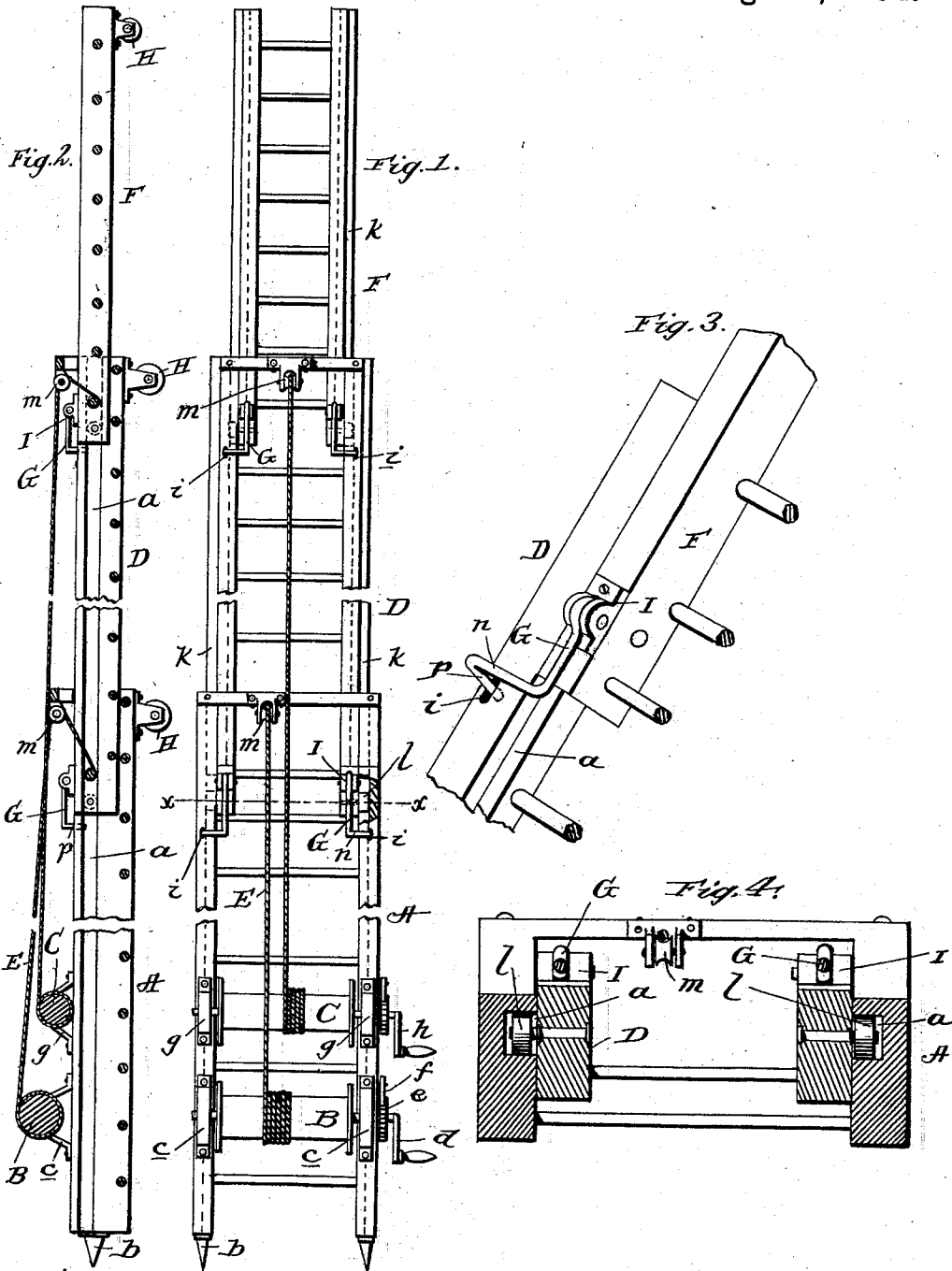

Witnesses:
[Signature]
W. F. Matthews.

Inventor
M. B. Monroe
By *[Signature]*
Attorney

UNITED STATES PATENT OFFICE.

MARION BAKER MONROE, OF NEW ORLEANS, LOUISIANA.

EXTENSION-LADDER.

SPECIFICATION forming part of Letters Patent No. 524,784, dated August 21, 1894.

Application filed February 2, 1894. Serial No. 498,868. (No model.)

To all whom it may concern:

Be it known that I, MARION BAKER MONROE, a citizen of the United States, residing at New Orleans, in the parish of Orleans and State of Louisiana, have invented certain new and useful Improvements in Extension-Ladders; and I do declare the following to be a full, clear, and exact description of the invention, such as will enable others skilled in the art to which it appertains to make and use the same.

This invention has relation to improvements in extension ladders designed more particularly for escape purposes in cases of fire, and it has for its prime object to provide such devices at a comparatively small expense and which will permit of a quick and ready use, and will afford a construction by which the various sections may be snugly nested so as to occupy but little space when not in use.

Other objects and advantages will appear from the following description and claims, when taken in connection with the annexed drawings, in which—

Figure 1, is a front view of my improved ladder, showing the same extended or raised to its fullest extent and ready for use. Fig. 2, is a central, longitudinal, sectional view of the same. Fig. 3, is a perspective detail view, and: Fig. 4, is a cross sectional view taken in the plane indicated by the dotted line *x, x*, on Fig. 1.

In carrying out my invention, I employ any suitable number of ladder sections; there being three shown in the present illustration, but it is obvious that more may be used, or in some cases, simply two sections might be employed.

Referring by letter to said drawings: A, indicates the main or base ladder section. This section, which is mainly of the ordinary ladder construction, has its side rails plowed out or recessed longitudinally on their inner sides, as shown at *a*, for a purpose which will presently appear, and the lower ends of the rails are provided with barbs or points *b*, to penetrate the ground or other support, and keep the ladder from slipping while in use, or while extending the sections. This lower or base ladder is provided on its side rails, at a suitable distance from their lower ends, with op-

positely arranged brackets *c*, in which is journaled a drum or roller B, carrying an operating handle *d*, and on the shaft of this drum a ratchet *e*, may be employed, and a pawl *f*, 55 pivoted to the ladder rail, so as to engage said ratchet, or any suitable means might be employed to lock the drum, when desired. The side rails of this ladder A, are also provided at a suitable distance above the brackets *c*, 60 with similar brackets *g*, and in these brackets is journaled another drum C, having an operating handle *h*, and a pawl and ratchet, similar to the one above described, is employed for a similar purpose. The side rails 65 of this ladder are furthermore provided at a suitable distance from their upper ends, with apertures *i*, to receive a latch, as will be presently described.

D, indicates the second or next section of 70 ladder. This section is mainly of the same construction as the first section, but in addition to having a longitudinal groove in the inner sides of the side rails, it also has a longitudinal tongue or projection *k*, in its outer 75 sides to enter the groove *a*, of the first section. In order to ease the movements of the second section in the grooves of the first section, I employ friction rollers *l*, at suitable points, which are designed to travel in said grooves. 80 This second section is provided with latch-holes or apertures *i*, similar to those of the first section, and each section carries a pivoted latch or catch, as shown.

E, indicates a lifting rope or cable. This 85 rope is wound at one end upon the drum B, and after passing through a pulley *m*, has its opposite end secured to the lower portion or end of the next ladder section; the lower round being a convenient place for attach- 90 ment. It will thus be seen that as the drum B, has been turned to wind the rope, the next ladder section will be elevated or drawn out of the first ladder section. There should be a drum for each section of ladder employed, 95 and it will be seen that as the drum C, is turned to wind the rope, it will raise the next or top section F; a pulley *m*, being also employed at the top of the second ladder section.

G, indicates a pivoted or gravitating catch, 100 and for the sake of stability, there are two employed on each ladder section. These

catches are of a form substantially as shown in Fig. 3, of the drawings, having a lateral branch n , and an angular branch p , to enter the apertures of the contiguous ladder sections. These catches are journaled one on each side rail of the ladders near their lower ends, and as the ladders have been raised to their fullest extent, the catches will automatically enter the slots or apertures of the contiguous sections, and firmly secure the two together. Each ladder section is also provided at or near its upper end with one or more friction rollers H , so that in elevating the ladders, they may travel against a wall or the like, without causing any undue friction or strain upon the ropes. The catches are journaled at their upper ends in suitable boxes or bearings I , and by simply throwing them up against the ladder rails, the ladders will be free to slide or nest in each other while being lowered.

It is obvious that my improvements may be applied to ladders without materially altering their present construction, and the invention can be carried out at a very small expense.

Having described my invention, what I claim is—

1. The herein described extension ladder comprising the base section having holes or sockets i , in its side rails at points adjacent to the upper ends thereof, a slidable section connected with the base section, and the gravitating latches pivotally connected to the side

rails of the slidable section and having lateral branches n , and angular branches p ; the said angular branches p , being designed and adapted to automatically engage the holes or sockets i , of the base section when the slidable section is raised, substantially as specified.

2. The herein described extension ladder consisting essentially of the base section having holes or sockets i , in its side rails at points adjacent to the upper ends thereof and also having longitudinal recesses a , in the inner sides of said side rails, the slidable section having longitudinal tongues upon the outer sides of its side rails adapted to engage the recesses in the rails of the base section and also having anti-friction rollers adapted to travel in said recesses, a suitable means for raising the slidable section, and gravitating latches pivotally connected to the side rails of the slidable section and having lateral branches n , and angular branches p ; the said angular branches p , being designed and adapted to automatically engage the holes or sockets i of the base section when the slidable section is raised, substantially as and for the purpose set forth.

In testimony whereof I affix my signature in presence of two witnesses.

MARION BAKER MONROE.

Witnesses:

GEO. W. SADLER,
JNO. L. ROBBINS.