



(11) **EP 3 502 003 A1**

(12) **EUROPEAN PATENT APPLICATION**

(43) Date of publication:  
**26.06.2019 Bulletin 2019/26**

(51) Int Cl.:  
**B65D 21/02 (2006.01) B65D 43/16 (2006.01)**

(21) Application number: **18215501.0**

(22) Date of filing: **21.12.2018**

(84) Designated Contracting States:  
**AL AT BE BG CH CY CZ DE DK EE ES FI FR GB GR HR HU IE IS IT LI LT LU LV MC MK MT NL NO PL PT RO RS SE SI SK SM TR**  
Designated Extension States:  
**BA ME**  
Designated Validation States:  
**KH MA MD TN**

• **Gallotti, Emanuele**  
**00019 Tivoli (RM) (IT)**

(72) Inventor: **GALLOTTI, Giuseppe**  
**00019 TIVOLI (RM) (IT)**

(74) Representative: **Santi, Filippo et al**  
**Barzanò & Zanardo Roma S.p.A.**  
**Via Piemonte 26**  
**00187 Roma (IT)**

(30) Priority: **22.12.2017 IT 201700149150 U**

(71) Applicants:  
• **Gallotti, Danila**  
**00019 Tivoli (RM) (IT)**

(54) **PACKAGING FOR FOOD, IN PARTICULAR FOR PIZZA**

(57) The present invention relates to a container (10) for food, in particular for pizza, comprising a base (11) and a lid (12), coupled on one side, said base (11) having

flared side walls (14), characterised by the fact that said container (10) is made of compact cardboard of pure long-fiber cellulose.

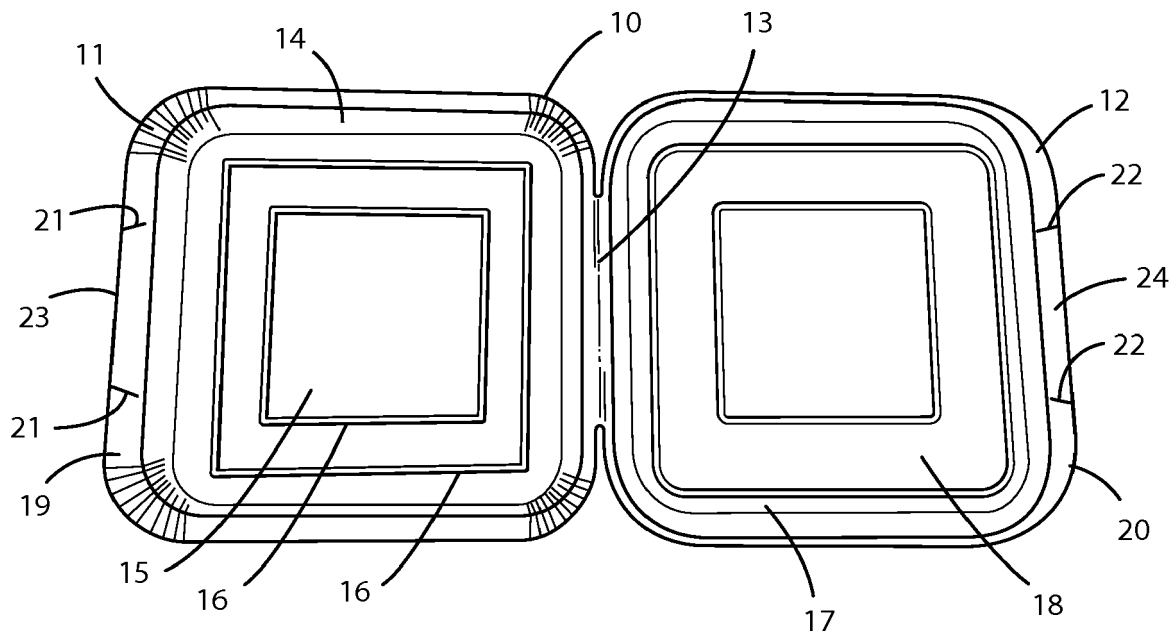

**Fig. 1**

**EP 3 502 003 A1**

## Description

**[0001]** The present invention relates to a container for food, in particular for pizza.

**[0002]** The invention refers to the field of packaging of wet and fatty food, such as, for example, ready-to-take pizza.

**[0003]** According to the Italian legislation dating back to 1973, containers intended for direct contact with wet and fatty food, if made of paper, must be produced exclusively with pure cellulose paper and without any paper waste.

**[0004]** Starting from this legislation, cardboard boxes spread to every take-away pizzerias, with a parallelepiped shape with a square base and a height of about a tenth of the side of the base, made from a corrugated cardboard blank, shaped in such a way that, once folded, it can assume the desired box shape.

**[0005]** A first problem of this type of solution is due to the time required for the assembly of the box. In fact, due to obvious space requirements, the blank is packaged for transport in its flattened form and is folded to form the real pizza box directly in the pizzeria. To avoid having to dedicate time to this operation during the period of maximum affluence of customers, the staff who work in the pizzerias fold the boxes in advance, to find them ready at the time of use.

**[0006]** This solution generates two additional problems, the first due to the fact that the mounted boxes occupy a space about five to seven times greater than the blanks from which they are obtained, the second for the possibility that in the already mounted boxes, which have holes whose function will be to allow the escape of the steam released by the pizza, dust and soot can enter and accumulate.

**[0007]** Moreover, the pizza boxes of a known type, if arranged to form a pile, as often happens when more than one take-away pizza is taken by one person, are free to slide on each other, with the risk that those arranged more at the top they can slip and fall.

**[0008]** Finally, the pizza boxes of the known type have a more or less high degree of toxicity, due to the fact that the corrugated cardboard is obtained by gluing together different layers with a starch-based glue added with 10% of caustic soda and the 10% of borax, two highly volatile chemicals that, at high temperatures such as those of the freshly baked pizza (about 80-90 °C), pass into the gas phase and are absorbed by the pizza, altering its smell and taste but above all making it toxic.

**[0009]** In this context it is proposed the solution according to the present invention, which aims to provide a container for food, particularly for pizza, completely non-toxic, already completely assembled and which can be stacked with other containers of the same type, both when opened, reducing to the maximum the total volume occupied, and when closed, maintaining the internal space necessary to hold the pizza, so as to prevent the sliding of one box on the other.

**[0010]** These and other results are obtained according to the present invention by proposing a container for food, in particular for pizza, made of compact cardboard of pure cellulose with long fiber, made with a hot drawing system.

**[0011]** The object of the present invention is therefore to provide a container for food, in particular for pizza, which allows to overcome the limits of the pizza boxes according to the prior art and to obtain the previously described technical results.

**[0012]** A further object of the invention is that said pizza container can be made with substantially low costs, both in terms of production costs and management costs.

**[0013]** Another object of the invention is to provide a container for food, particularly for pizza, which is simple, safe and reliable.

**[0014]** A specific object of the present invention therefore forms a container for food, in particular for pizza, comprising a base and a lid, coupled on one side, said base having flared side walls, wherein said container is made of compact cardboard of pure long fiber cellulose.

**[0015]** Preferably, according to the present invention, the bottom of said base has stiffening pads and said lid has a raised perimetrical relief with respect to the central part, of shape and size able to lodge with contact, along its entire internal perimeter, the base of an overlying container of the same type.

**[0016]** The present invention will now be described, by way of illustration, but not by way of limitation, according to a preferred embodiment thereof, with particular reference to the figures of the accompanying drawings, in which:

- Figure 1 shows a perspective view of a container for food, in particular for pizza, according to the present invention, in an open position,
- Figure 2 shows a perspective view of the container for food of Figure 1, in the closed position, and
- Figure 3 shows a perspective view of a plurality of containers for food such as that of Figure 1, stacked together, in an open position.

**[0017]** With reference to the figures, the container for food, in particular for pizza, according to the present invention is indicated in its entirety with the reference numeral 10 and consists of a blank of long fiber pure cellulose compact cardboard, shaped by hot drawing.

**[0018]** In particular, the container 10 comprises a base 11 and a lid 12, coupled along a folding line 13 of the blank. The base 11 has a square shape, with rounded corners, with side walls 14 flared with truncated-cone geometry, with the ideal vertex facing downwards, to allow stacking of several containers 10 on each other, in an open position, as shown in Figure 3. The base 15 of the base 11 has reliefs 16, with inclined connecting walls between the peak of the reliefs 16 and the bottom 15 of the base 11, the reliefs 16 assuming a truncated conical section, with the ideal vertex facing towards the top, to

allow stacking of several containers 10 on top of each other with maximum reduction of the occupied space. The reliefs 16 have the function of rendering the bottom 15 of the base 11 more rigid.

**[0019]** The lid 12 has a square shape with rounded corners and has, next to its perimeter, a square-shaped relief 17 with a truncated cone section, with the ideal vertex facing upwards, with lid 12 closed, which surrounds the central part 18 of the lid, which is thus in a lower position, i.e., more towards the inside of the container 10, to allow, in an open position, the stacking of several containers 10 on each other, with maximum reduction of the volume occupied (as shown in figure 3), but also to allow the lid 12 to house, in the central part 17, the base 11 of a container 10 of the same type, resting on it.

**[0020]** On the peripheral edge 19 of the base 11 and on the peripheral edge 20 of the lid 12, on the side opposite to that of the folding line 13, there are respective cuts 21, 22 of the blank, which define respective tabs 23, 24. The folding of the tabs 23, 24 allows to secure the lid 12 on the base 11 of the container 10.

**[0021]** The present invention has been described by way of illustration, but not of limitation, according to its preferred embodiments, but it is to be understood that variations and/or modifications may be made by those skilled in the art without thereby departing from the relative scope of protection, as defined from the attached claims.

## Claims

1. Container (10) for food, in particular for pizza, comprising a base (11) and a lid (12), coupled on one side, said base (11) having flared side walls (14), **characterised in that** said container (10) is made of compact cardboard of pure long-fiber cellulose.
2. Container (10) for food according to claim 1, **characterised in that** the bottom (15) of said base (11) has stiffening reliefs (16).
3. Container (10) for food according to claim 1 or 2, **characterised in that** said lid (12) has a peripheral relief (17) raised with respect to the central part (18), of shape and dimensions apt for housing with contact, along its entire internal perimeter, the base (11) of an overlying container (10) of the same type.

50

55

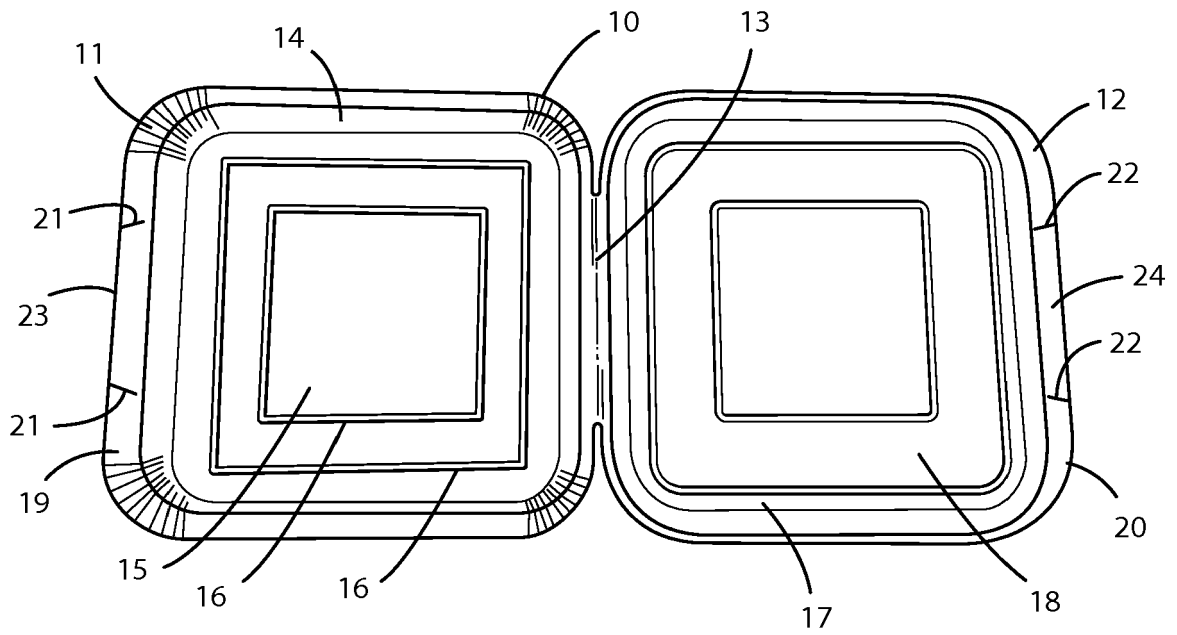

Fig. 1

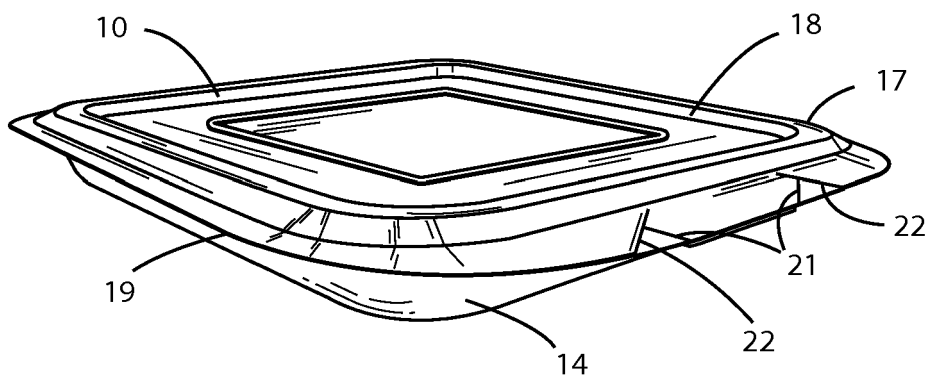

Fig. 2

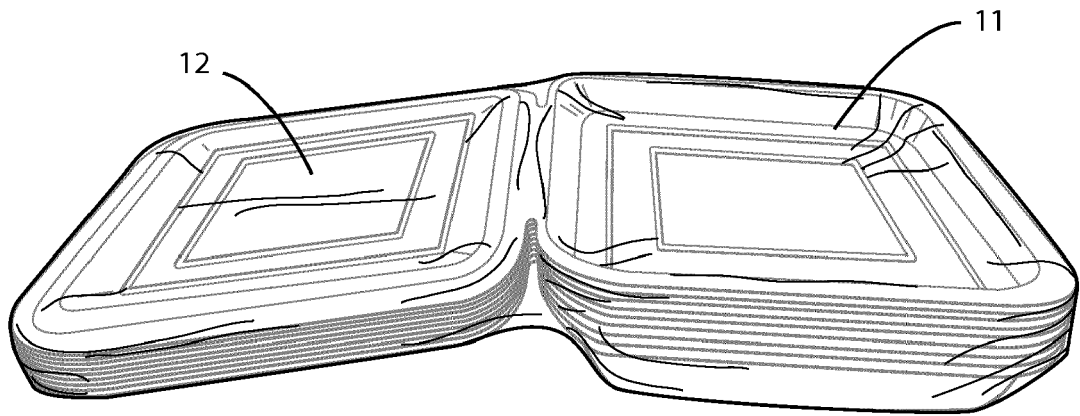

Fig. 3



EUROPEAN SEARCH REPORT

Application Number  
EP 18 21 5501

5

DOCUMENTS CONSIDERED TO BE RELEVANT			
Category	Citation of document with indication, where appropriate, of relevant passages	Relevant to claim	CLASSIFICATION OF THE APPLICATION (IPC)
10 Y	EP 2 243 723 A1 (GALLOTTI EMANUELE [IT]; GALLOTTI DANILA [IT]) 27 October 2010 (2010-10-27) * paragraph [0018] * -----	1-3	INV. B65D21/02 B65D43/16
15 Y	ES 2 552 741 A1 (MUNOZ GONZALEZ JOSÉ ANDRES [ES]; MARCH VILA MARIA FATIMA [ES]) 1 December 2015 (2015-12-01) * page 3, lines 9-11 * -----	1-3	
20 Y	US 2006/144744 A1 (RODRIQUEZ GEORGE [US] ET AL) 6 July 2006 (2006-07-06) * paragraph [0050]; figure 4 * -----	3	
25			
30			TECHNICAL FIELDS SEARCHED (IPC) B65D
35			
40			
45			
50	The present search report has been drawn up for all claims		
	Place of search <b>Munich</b>	Date of completion of the search <b>26 March 2019</b>	Examiner <b>Jervelund, Niels</b>
55	CATEGORY OF CITED DOCUMENTS X : particularly relevant if taken alone Y : particularly relevant if combined with another document of the same category A : technological background O : non-written disclosure P : intermediate document T : theory or principle underlying the invention E : earlier patent document, but published on, or after the filing date D : document cited in the application L : document cited for other reasons ..... & : member of the same patent family, corresponding document		

EPO FORM 1503 03 82 (P04C01)

**ANNEX TO THE EUROPEAN SEARCH REPORT  
ON EUROPEAN PATENT APPLICATION NO.**

EP 18 21 5501

5 This annex lists the patent family members relating to the patent documents cited in the above-mentioned European search report.  
The members are as contained in the European Patent Office EDP file on  
The European Patent Office is in no way liable for these particulars which are merely given for the purpose of information.

26-03-2019

Patent document cited in search report	Publication date	Patent family member(s)	Publication date
EP 2243723 A1	27-10-2010	AT 544698 T	15-02-2012
		EP 2243723 A1	27-10-2010
		ES 2386170 T3	10-08-2012
		IT 1393856 B1	11-05-2012
		SM T201200019 B	10-07-2012
-----			
ES 2552741 A1	01-12-2015	NONE	
-----			
US 2006144744 A1	06-07-2006	NONE	
-----			

EPO FORM P0459

For more details about this annex : see Official Journal of the European Patent Office, No. 12/82