

(12) UK Patent Application (19) GB (11) 2490888 (13) A

(43) Date of A Publication 21.11.2012

(21) Application No: 1108067.8

(22) Date of Filing: 15.05.2011

(71) Applicant(s):  
Innovative Patent Limited  
PO Box 111, Neot Golf, Caesarea 38900, Israel

(72) Inventor(s):  
Ron Chen

(74) Agent and/or Address for Service:  
Fisher Weiler Group  
Portland House, 16th floor, Bressenden Place,  
London, SW1E 5RS, United Kingdom

(51) INT CL:  
F03G 7/08 (2006.01) E01F 9/047 (2006.01)  
H02K 7/18 (2006.01)

(56) Documents Cited:  
GB 1332202 A WO 2008/035348 A2  
WO 1986/007504 A1 US 20040160058 A1  
US 20020089309 A1  
KR1020090099117 A

(58) Field of Search:  
INT CL E01F, F03G, H02K  
Other: ONLINE:WPI, EPODOC

(54) Title of the Invention: **Improved road-based electricity generator**  
Abstract Title: **System for generating electricity from wheeled vehicles moving along a road**

(57) The system comprises a flap 110A, 110B, hingedly connected to a frame 111 and movable by a passing vehicle wheel between a protruding, upwardly inclined state and a state where it is level with the road. A vertical rack 125 is pivotally connected by a bar 120 to the flap and a pinion 135 is mounted on an input axis 136 and arranged to turn upon vertical movement of the rack due to movement of the flap. A transmission 130 is connected to the input axis to transmit only rotations thereof due to downward movements of the rack to an output axis, and to de-couple the input axis from the output axis upon rotations resulting from upward movements of the rack. A flywheel 150 is connected to the output axis and arranged to be rotated by the transmission to operate an alternator to produce electricity. Also claimed is a method of generating electricity.

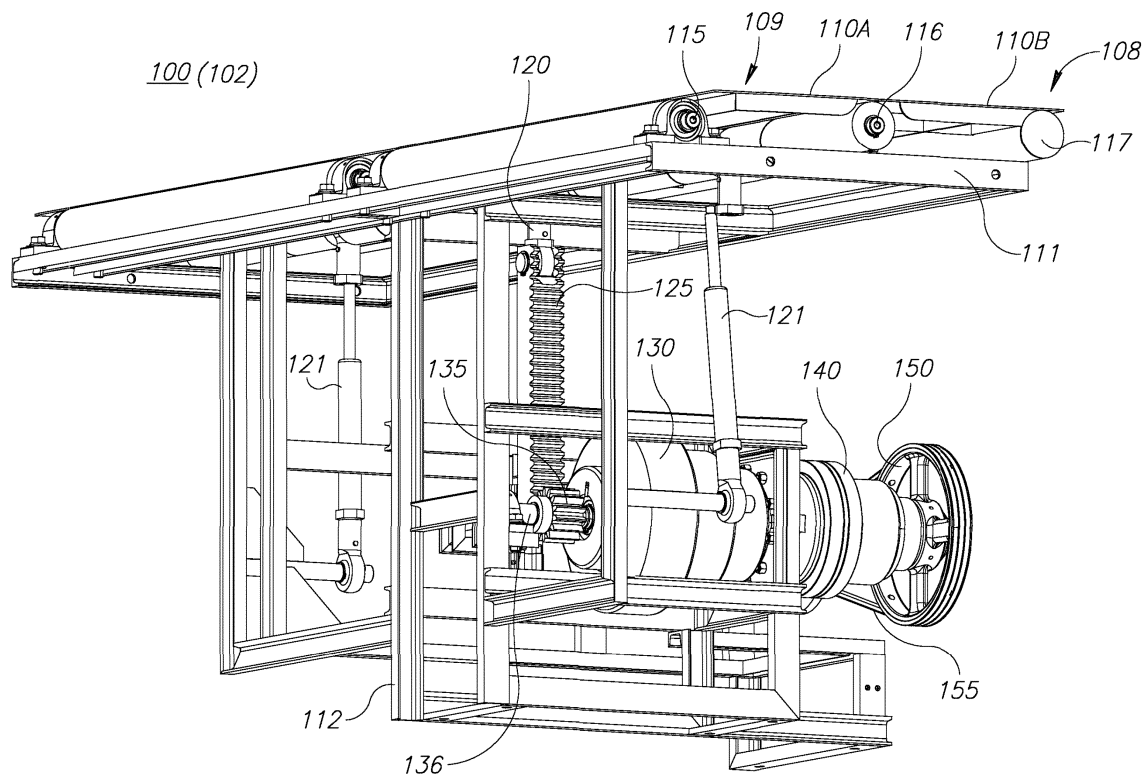

Figure 2B

GB 2490888 A

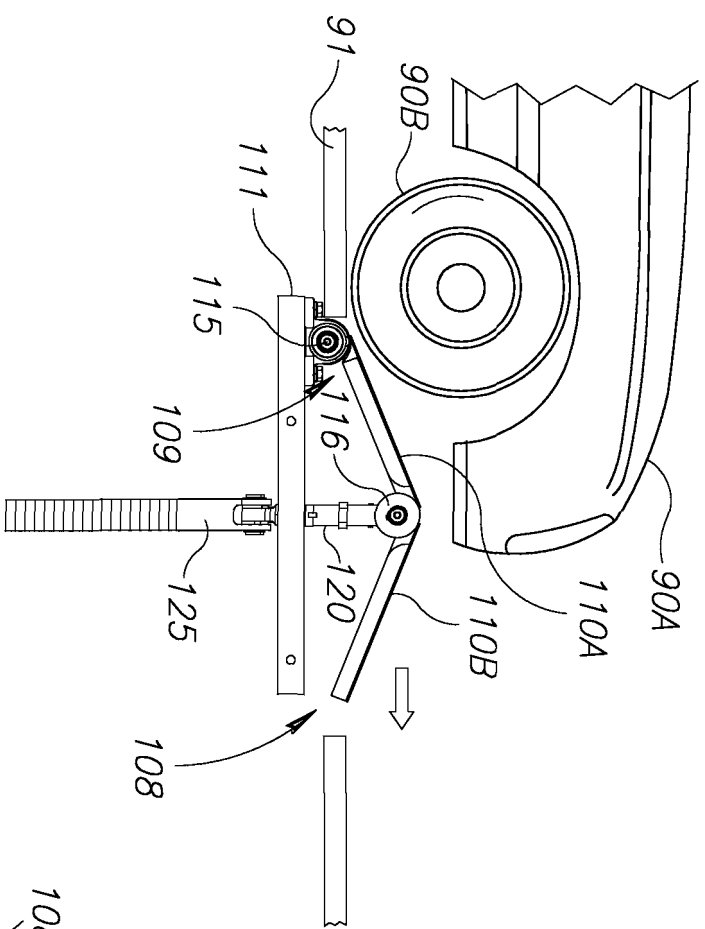

Figure 1A

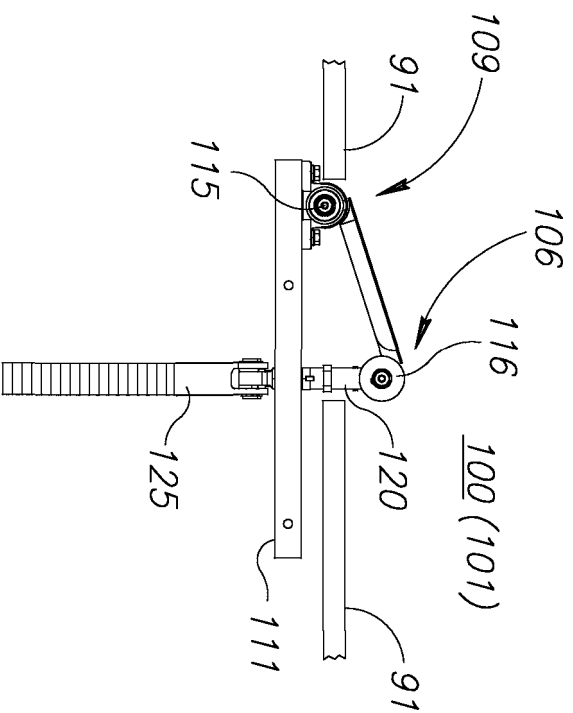

Figure 1B

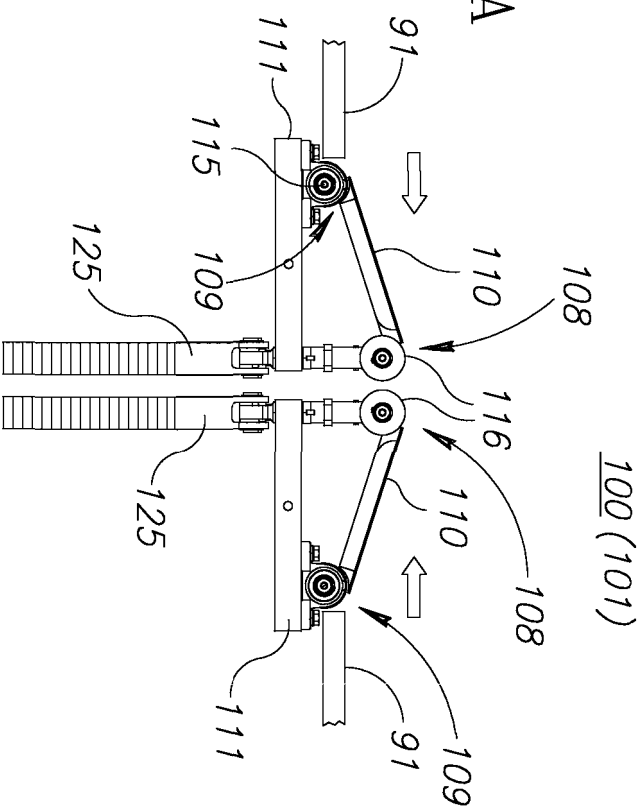

Figure 1C

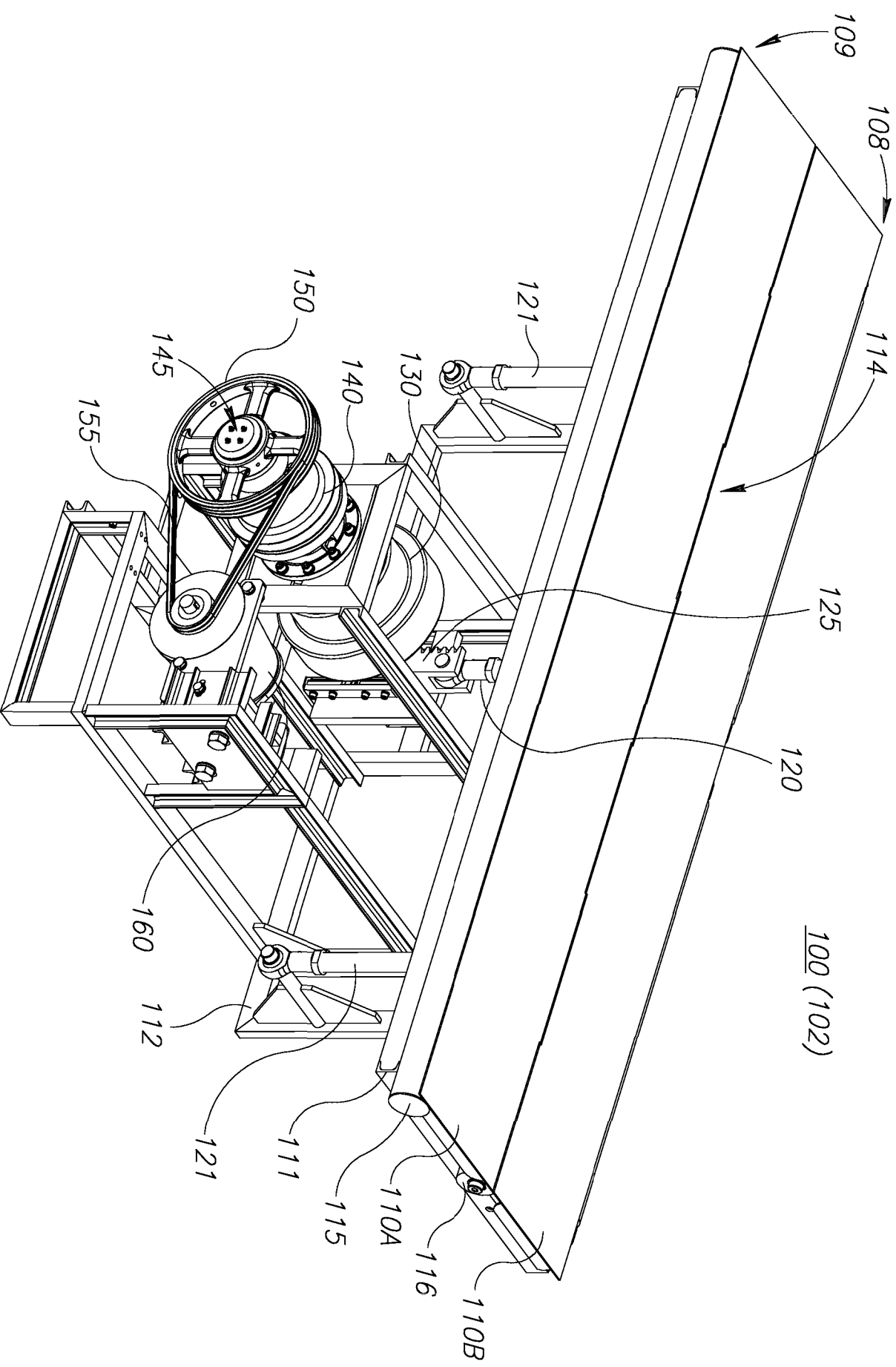

Figure 2A

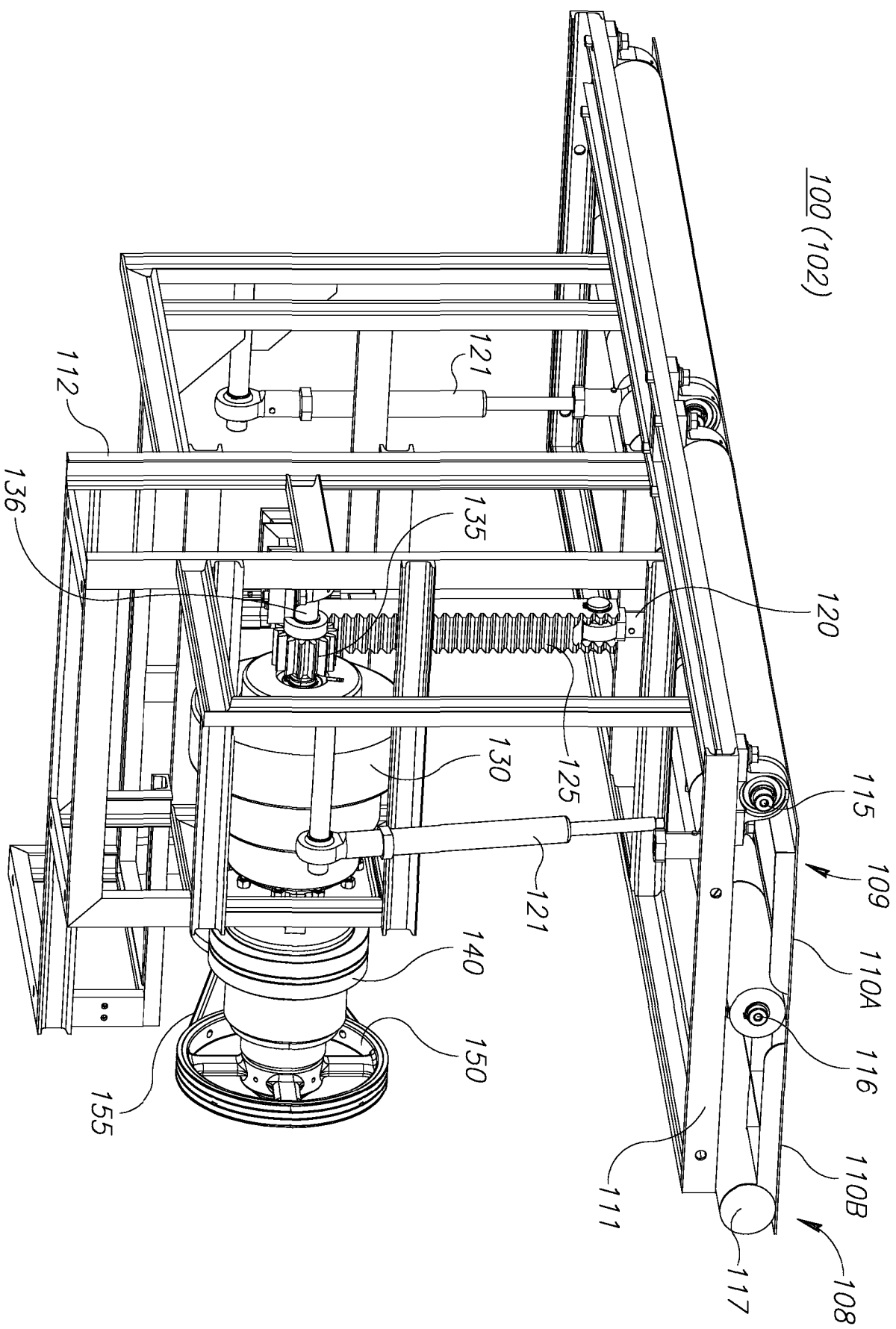

Figure 2B

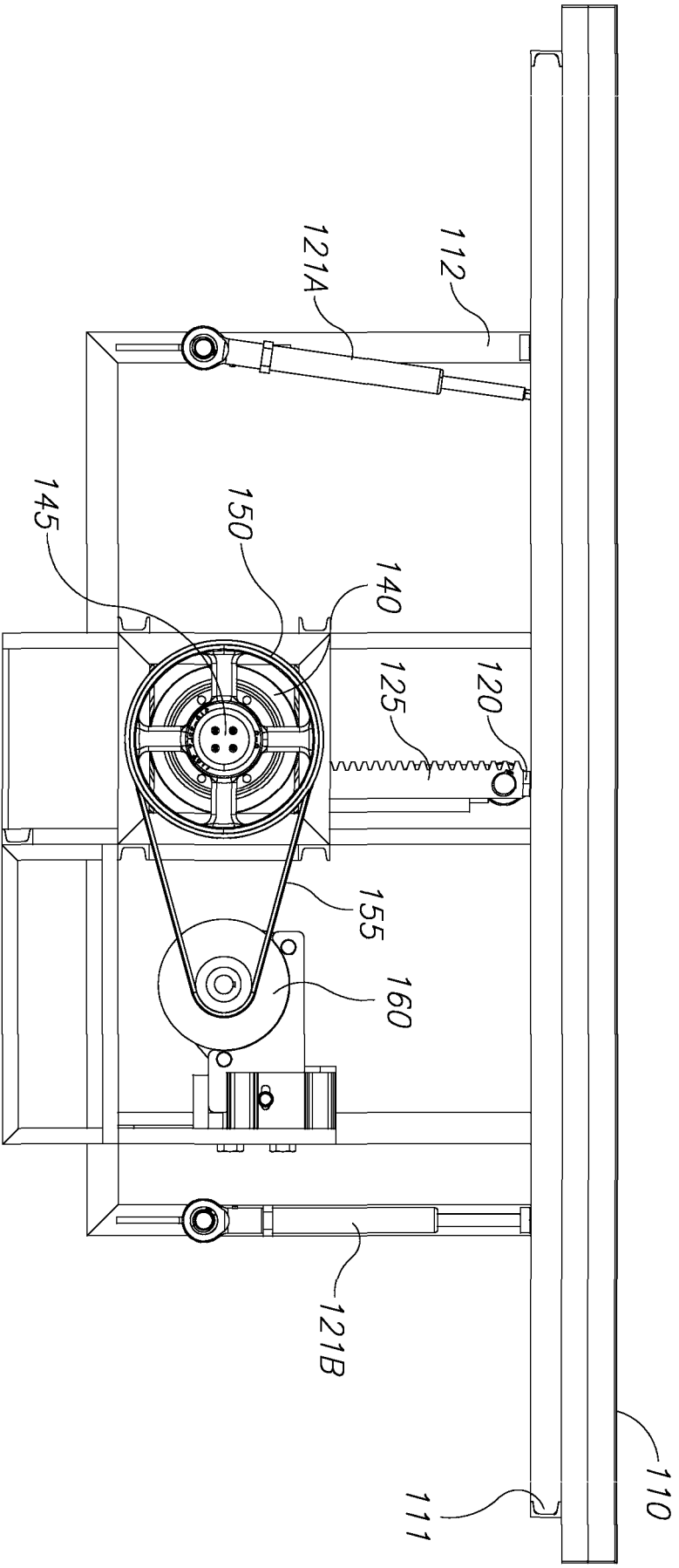

Figure 3

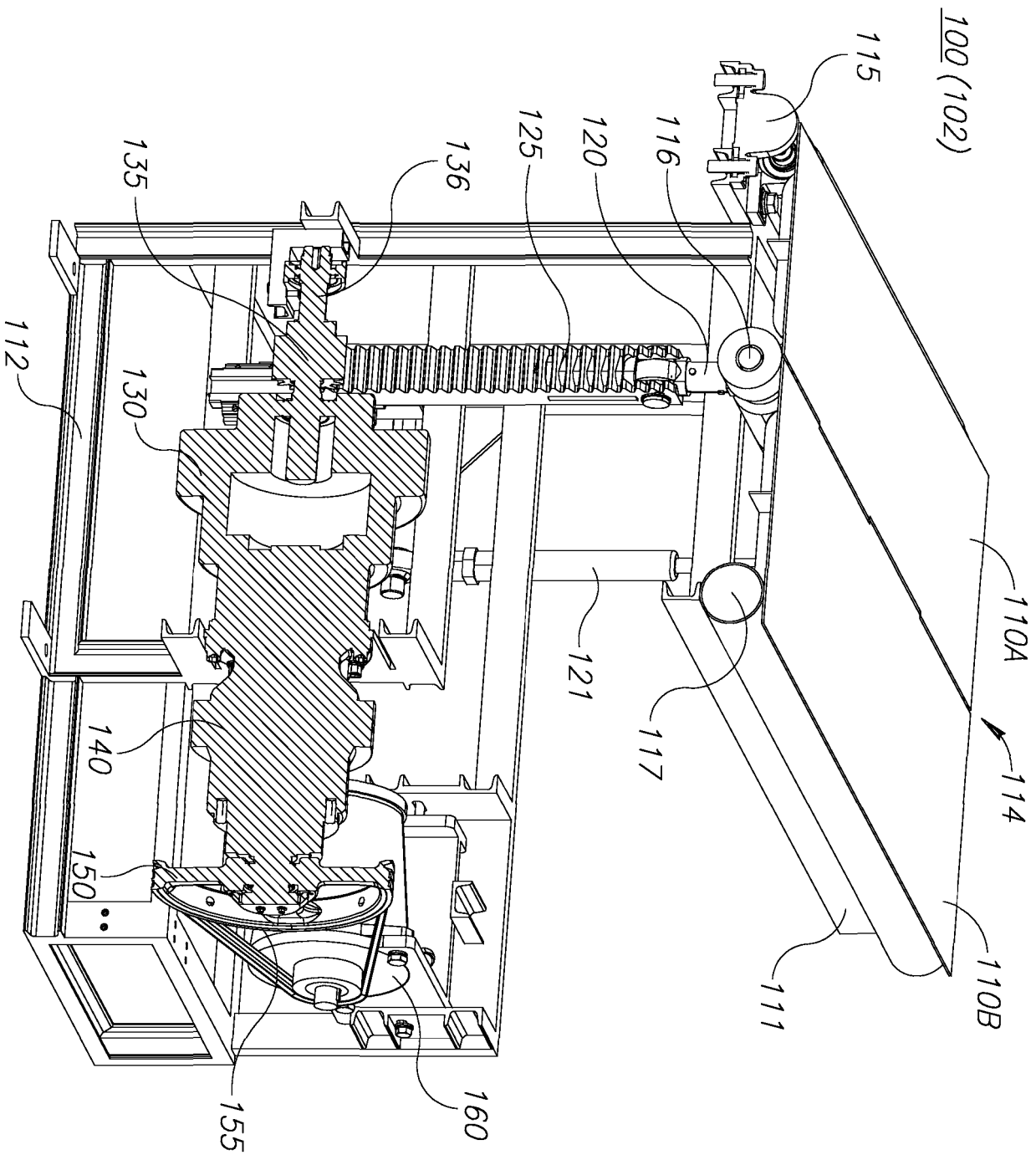

Figure 4

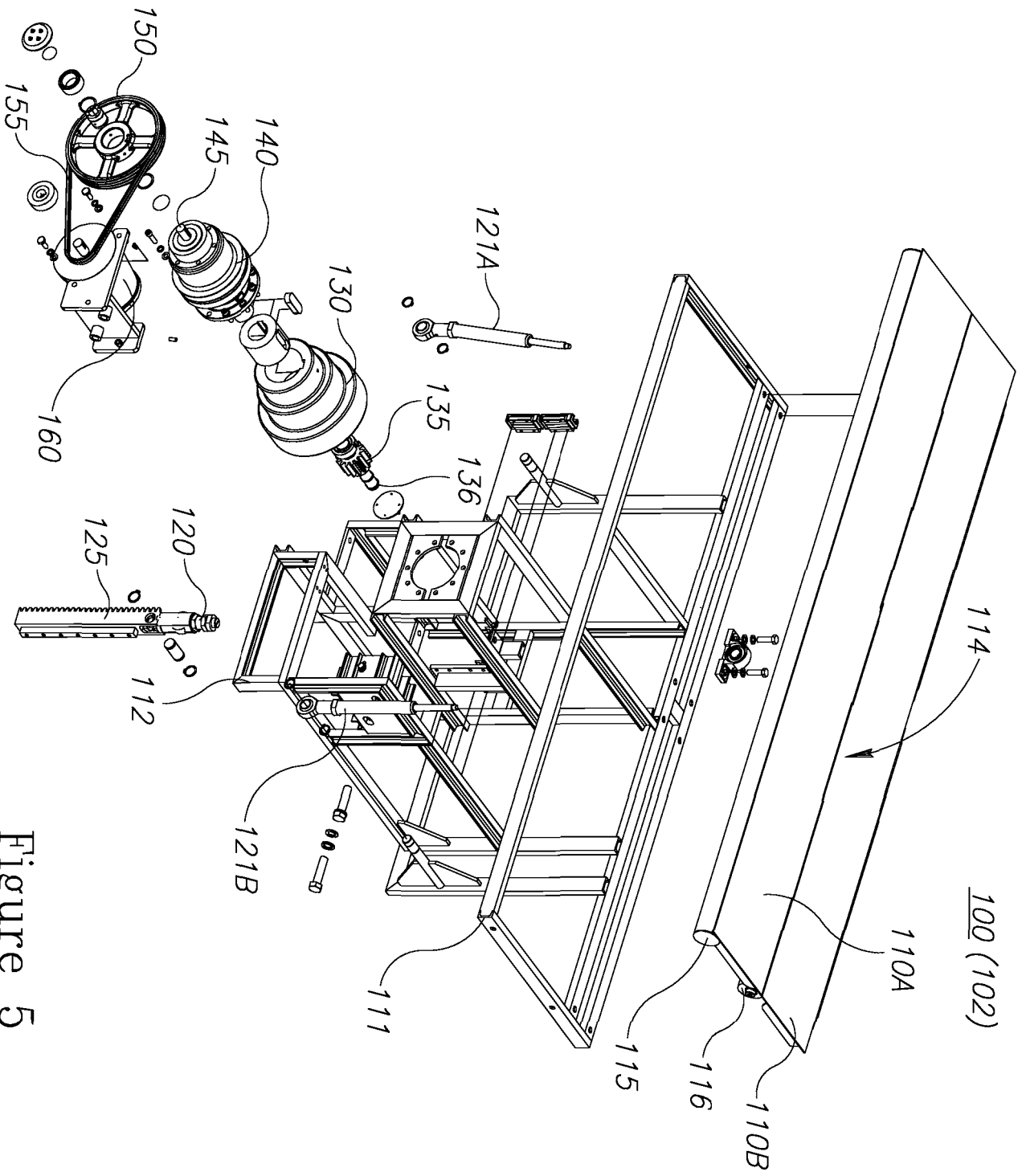

Figure 5

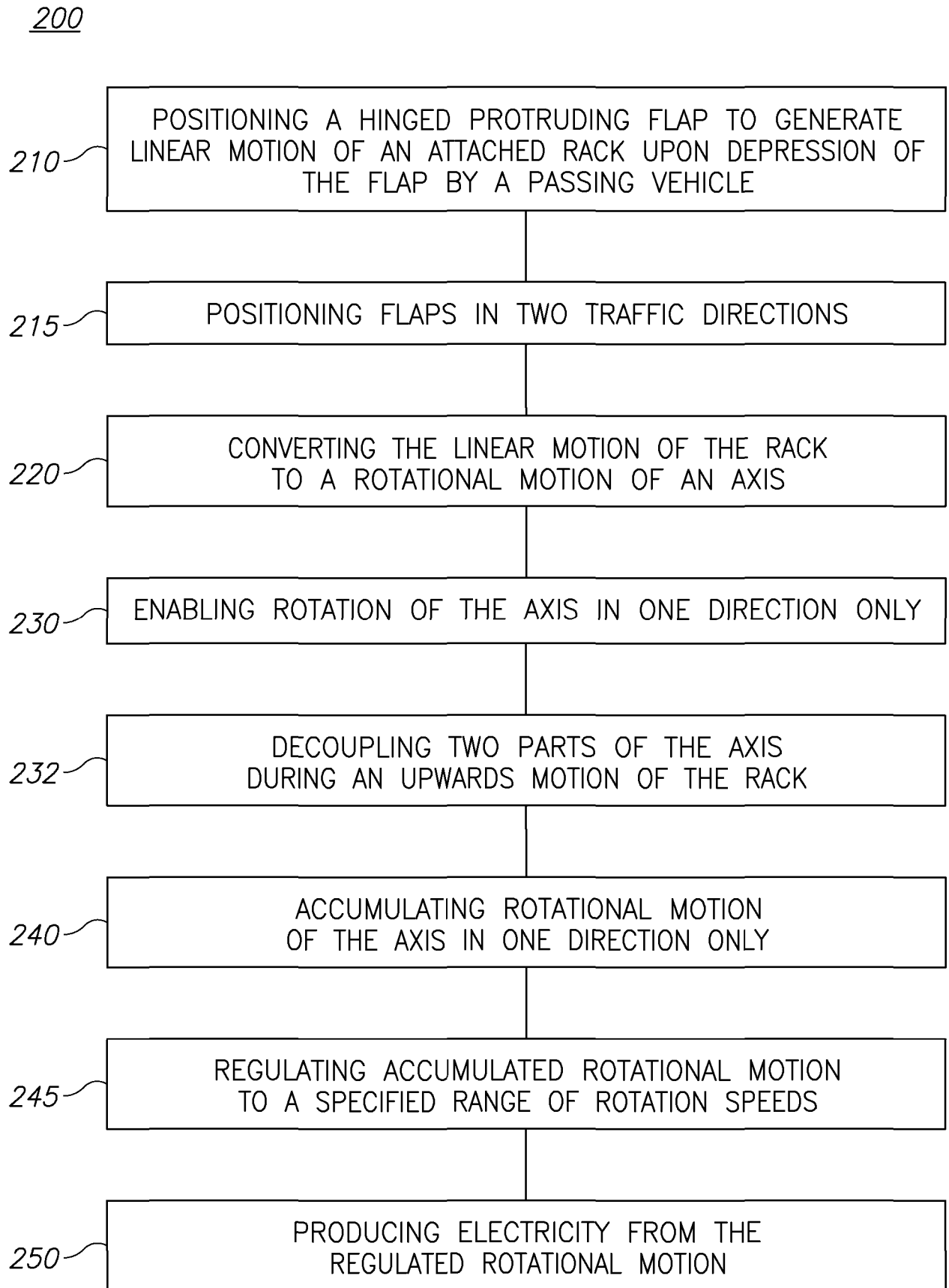

Figure 6



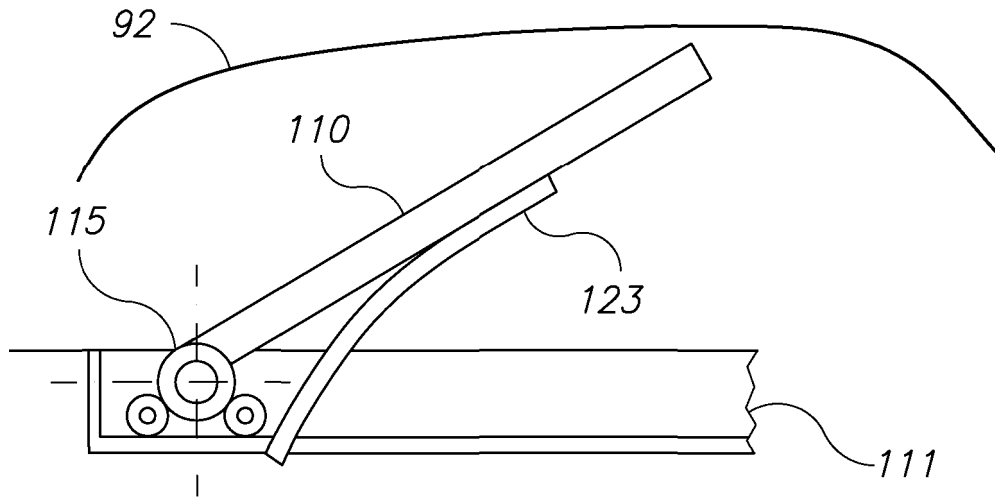

FIG. 7A

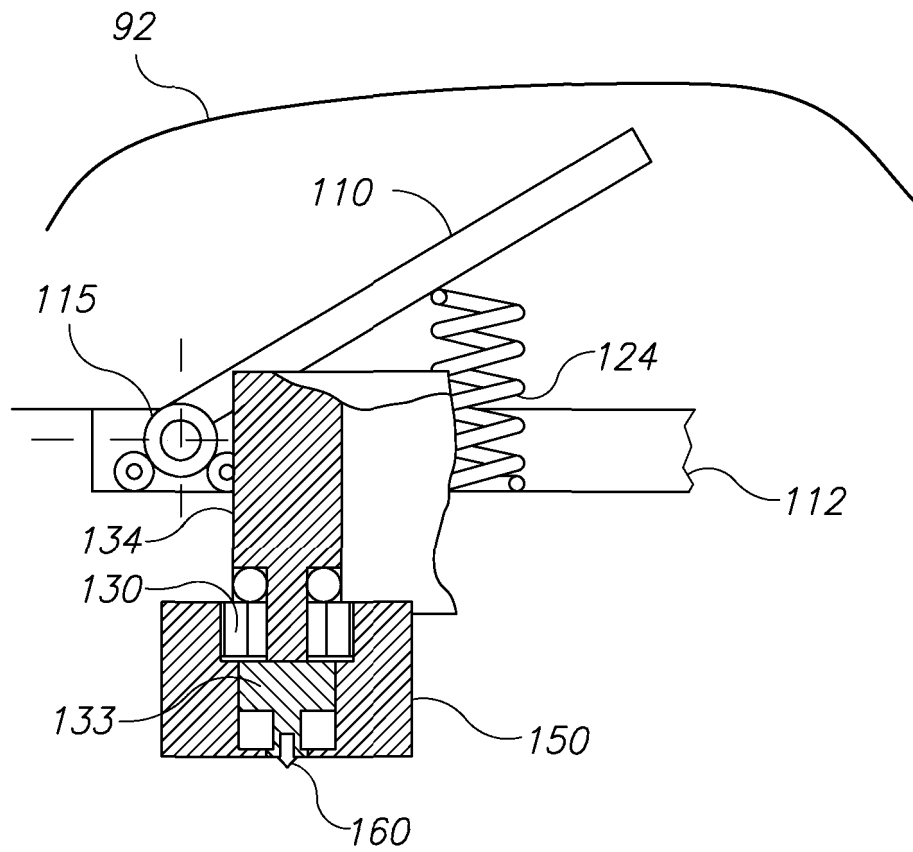

FIG. 7B

# IMPROVED ROAD-BASED ELECTRICITY GENERATOR

## BACKGROUND

### 1. TECHNICAL FIELD

[0001] The present invention relates to renewable energy, and more particularly, to energy generation from vehicles.

### 2. DISCUSSION OF THE RELATED ART

[0002] The massive road traffic is a potential energy resource. Various publications, such as U.S. Patent 4238687 and German Patent documents 4034219 and 10108265, describe devices designed to generate energy from passing vehicle by causing them to actuate a rotating device. However, these documents are impractical as they do not deal with the overall effect of many actuations, and do not allow efficient energy conversion from them. The problem thus remains – how can energy be effectively extracted from passing cars?

## BRIEF SUMMARY

[0003] One aspect of the invention provides a system for electricity generation from a plurality of wheeled vehicles moving along a road, the system comprising: a flap, hingedly connected at a first end at a road level to a frame, and having two states: (i) a protruding state, in which the flap is inclined upwards and a second end of the flap is above road level, and (ii) a level state, in which the flap is on a level with the road, wherein the flap is arranged to be moved from the protruding state to the level state by vehicles moving across the flap and pushing down the second end of the flap, a rack and a pinion, the rack being vertical and jointedly connected by a bar to the second end of the flap, and the pinion being mounted on an input axis and arranged to turn upon vertical movement of the rack due to the vertical pushing down of the second end of the flap by passing vehicles, a transmission connected to the input axis and arranged to transmit only rotations thereof due to downward movements of the rack to an output axis, and de-couple the input axis from the output axis upon rotations of the former resulting from upward movements of the rack, to accumulate rotations in one direction, and a flywheel connected to the output axis and arranged to receive the transmitted rotations from the transmission, and operate an alternator over a belt to produce electricity from the accumulated rotation of the flywheel.

## **BRIEF DESCRIPTION OF THE DRAWINGS**

[0004] For a better understanding of embodiments of the invention and to show how the same may be carried into effect, reference will now be made, purely by way of example, to the accompanying drawings in which like numerals designate corresponding elements or sections throughout.

[0005] In the accompanying drawings:

**Figures 1A-1C** are high level schematic illustrations of the operation and some configurations of flaps in a system for electricity generation from a plurality of wheeled vehicles moving along a road, according to some embodiments of the invention,

**Figures 2A-2B** are perspective views of a system for electricity generation from a plurality of wheeled vehicles moving along a road, according to some embodiments of the invention,

**Figure 3** is a side view and **Figure 4** is a cross sectional side view of a system for electricity generation from a plurality of wheeled vehicles moving along a road, according to some embodiments of the invention,

**Figure 5** is an exploded view of a system for electricity generation from a plurality of wheeled vehicles moving along a road, according to some embodiments of the invention,

**Figure 6** is a high level flowchart illustrating a method of energy generation from a plurality of wheeled vehicles moving along a road, according to some embodiments of the invention, and

**Figures 7A** and **7B** are schematic diagrams of the system according to the present invention without and with (respectively) the electrical conversion means, according to some embodiments of the invention.

[0006] The drawings together with the following detailed description make apparent to those skilled in the art how the invention may be embodied in practice.

## **DETAILED DESCRIPTION**

[0007] With specific reference now to the drawings in detail, it is stressed that the particulars shown are by way of example and for purposes of illustrative discussion of the preferred embodiments of the present invention only, and are presented in the cause of providing what is believed to be the most useful and readily understood description of the principles and conceptual aspects of the invention. In this regard, no attempt is made to show structural details of the invention in more detail than is necessary for a fundamental understanding of the invention, the description taken with the drawings making apparent to those skilled in the art how the several forms of the invention may be embodied in practice.

[0008] Before explaining at least one embodiment of the invention in detail, it is to be understood that the invention is not limited in its application to the details of construction and the arrangement of the components set forth in the following description or illustrated in the drawings. The invention is applicable to other embodiments or of being practiced or carried out in various ways. Also, it is to be understood that the phraseology and terminology employed herein is for the purpose of description and should not be regarded as limiting.

[0009] **Figures 1A-1C** are high level schematic illustrations of the operation and some configurations of flaps **110** in a system **100** for electricity generation from a plurality of wheeled vehicles **90A** moving along a road **91**, according to some embodiments of the invention.

[0010] System **100** comprises a flap **110**, hingedly connected at a first end **109** at a road level by a pivot **115** to a frame **111**. Flap **110** may comprise a single flap (**Figure 1B**), an articulated flap having flap **110A** and a flap extension **110B** that form a bump like protrusion in road **91** (**Figure 1A**) or two systems **100** may be opposedly combined (installed pairwise in a back to back configuration) to form a bump like protrusion in road **91** (**Figure 1C**). The formation of flap 10 depends on the expected traffic on road **91** and the expected traffic directions (marked by arrows).

[0011] System **100**, and especially flap **110**, have two states: (i) a protruding state **101** (**Figures 1A-1C**), in which flap **110** is inclined upwards and a second end **108** of flap **110** is above road level, and (ii) a level state **102** (**Figures 2-5**), in which flap **110** is on a level with road **91**.

[0012] Flap **110** is arranged to be moved from protruding state **101** to level state **102** by wheels **90B** of vehicles **90A** moving across flap **110** and pushing down second end **108** of flap **110**. The rotation of flap **110** in respect to pivot **115** is translated to a rotational movement which is in turn used to generate electricity, as described below.

[0013] System **100** utilizes the recurring tilting of flap **110** by vehicles' wheels **90B** to accelerate a flywheel and then convert the tilting motion to energy after a baseline rotational energy has been accumulated.

[0014] **Figures 2A-2B** are perspective views, **Figure 3** is a side view and **Figure 4** is a cross sectional side view, and **Figure 5** is an exploded view, all of system **100**, according to some embodiments of the invention.

[0015] System **100** comprises a rack **125** which is connected to second end **108** of flap **110**, e.g. via pivot **116** and bar **120**. Second end **108** may be at the end of flap **110** (**Figures 1B, 1C**) or in the middle of flap **110**, as illustrated in **Figure 1A**. The connection of rack **125** to flap **110** may be jointed to receive a horizontal component of force resulting from the rotation of flap **110** in respect to pivot **115**. Rack **125** (in an essentially vertical position) is coupled to a pinion **135** which is mounted on an input axis **136** (in an essentially horizontal position). Pinion **135** is arranged to turn upon vertical movement of rack **125** due to the vertical pushing down of second end **108** of flap **110** by passing vehicles **90A**, and thus translate the linear motion of rack **125** to a rotational motion of input axis **136**.

[0016] System **100** further comprises a transmission **130** connected to input axis **136** and arranged to transmit only rotations thereof due to downward movements of rack **125** to an output axis **145**, and de-couple input axis **136** from output axis **145** upon rotations of the former resulting from upward movements of rack **125**, to accumulate rotations in one direction. Transmission **130** may comprise any type of power transmission, such as an automatic clutch. Transmission **130** allows rack **125** to return upwards while keeping contact with pinion **135**, and to move flaps **110** back to protruding state **101**, without annulling the generated rotation.

[0017] The rotational motion of output axis **145** is then transferred through a gear **140** to a flywheel **150** that is connected to output axis **145** and arranged to receive the transmitted rotations from transmission **130**, and operate an alternator **160** over a belt **155** to produce electricity from the accumulated rotation of flywheel **150**.

[0018] Edges **114** (**Figure 2A**) of compound flap **110**, i.e. the contact area between flap **110A** and extension **110B**, may be formed to ensure a smooth transition between protruding state **101** and level state **102** and continuous operation of system **100** over numerous vehicle passes.

[0019] System **100** may be embedded under road **91**, within a frame **112** that may be connected to frame **11** from below. The various parts of system **100**, such as transmission **130**, gear **150**, flywheel **150** and alternator **160** may be anchored to frame **112**. Frame **112** may further support the smooth transition between protruding state **101** and level state **102** by supporting flap **110** at additional points except from rack **125** and bar **120**, for example by stabilizers **121** (**Figures 2A-2C**), such as piston, springs, air springs, etc. attached to frame **112**.

[0020] Flap extension **110B** may be supported by a support **117** (**Figures 2B, 4**). For example, pivots **115**, **116** and support **117** may be cylindrical. In particular support **117** may be arranged to allow the extension edge roll along frame **111** during the transition between protruding state **101** and level state **102**.

[0021] Stabilizers **121** are arranged to stabilize flap **110** in its up and down movements, as well as to stabilize it in forwards-backwards movements resulting from its angular motion in respect to pivot **115**. These motions are illustrated in **Figures 3** and **5** in the oblique position of stabilizer **121A** in respect to stabilizer **121B**. Of course, both stabilizers **121A** and **121B** may be arranged to be in an oblique position, e.g. in level state **102**, when flap **110** is at level with the road.

[0022] It is noted, that system **100** as described below first accumulates the rotational movements produced by single vehicles **90A** to reach a minimal extent of rotation before starting the actual production of electricity. Then system **100** starts to convert additional rotations to electricity, while maintaining the rotational speed of flywheel **150** at a specified level. In this way, electricity is produced continuously and is used effectively by a load, such as charging batteries or other storage forms, road lighting system and so on. Gear **140** is used to maintain a specified rotation speed of flywheel **150** within specified limits, that optimize the generation of electricity.

[0023] System **100** may be positioned at various positions in roads, such along a straight section in which traffic jams often occur, at turns, at section with expected specified vehicle speeds that optimize the efficiency of the system, etc.

[0024] Several systems **110** may be installed adjacent to each other, to multiply energy production in the location.

[0025] **Figure 6** is a high level flowchart illustrating a method **200** of energy generation from a plurality of wheeled vehicles moving along a road, according to some embodiments of the invention.

[0026] Method **200** comprises the following stages: positioning a hinged protruding flap to generate linear motion of an attached rack upon depression of the flap by a passing vehicle (stage **210**), converting the linear motion of the rack to a rotational motion of an axis (stage **220**, e.g. by a rack and a pinion) by enabling rotation of the axis in one direction only (stage **230**), regulating accumulated rotational motion (stage **240**) to a specified range of rotation speeds (stage **245**) and producing electricity from the regulated rotational motion (stage **250**).

[0027] Method **200** may comprise positioning flaps in two traffic directions (stage **215**) to generate electricity (**250**) from two-way traffic.

[0028] Enabling rotation of the axis in one direction only (stage **230**) may be carried out by a transmission arranged to decouple two parts of the axis during an upwards motion of the rack (stage **232**), one part attached to the pinion in a rack and pinion configuration, the other part accumulating rotation the enabled direction (stage **240**).

[0029] **FIG. 7A** shows a schematic diagram of the system according to the present invention without the electrical conversion means, according to some embodiments of the invention.

[0030] The system comprises an arced cover strip **92** that runs across a traffic lane or multiple lanes. The cover strip **92** is mounted upon a housing, or frame **111** that is embedded within the road, directly under the cover strip. The cover strip **92** is abutted upon a wing **110** that is attached to an axis of rotation **115** also located within the housing **111**. The upper end of the wing **110** touches the cover strip above the road level. The wing **110** is also connected to a spring **123**, such as a compression spring. Whenever the cover strip **92** is pressed down, the wing **110** rotates around the axis **115** and is subsequently returned to its original position by the spring **123**.

[0031] According to some embodiments of the invention, the wing **110** may be comprised of a plurality of adjacent wings that may be connected together in a telescopic manner.

[0032] **FIG. 7B** shows a schematic diagram of the system according to the present invention now with the electrical conversion means depicted, according to some embodiments of the invention.

[0033] The system further comprises, in addition to the aforementioned description of **FIG. 7A**, a fly wheel and a rotor **133**, a stator **134**, centered within the rotor **133**, a spring **124** (variant of **123**) connecting the wing **110** and the housing, or frame **112**, an electro-magnetic generator **160** connector to the rotor and a clutch **130**. The clutch **130** transfers the rotational motion to flywheel **150** and rotor **133** which activate in turn the electro-magnetic generator **160**. Vehicles driving over the cover strip **92** press it down causing the rotor to rotate and drive the generator to generate alternating current which is then modified and passed on. When the wing **110** is released, the spring **124** returns it back to the initial position.

[0034] According to some embodiments of the invention when the system, a relaxed phase (i.e., no vehicle over the cover strip) the cover strip is protruding above the surface of the road necessitating a driver to slow down.

[0035] According to some embodiments of the invention the electricity produced by the generator is then transferred to power supply connected to a stabilizer for accumulating the energy to be used for any electric powered appliance. Alternatively, it may be redirected to power grid via bi-directional power meter.

[0036] According to some embodiments of the invention, apart from the cover strip **92**, all the system's components are located inside the housing **112**, under road surface, thus imitating a the size and shape of a standard road hump.

[0037] According to some embodiments of the invention, multiple vehicles passing one after another transfer a small amount of its kinetic energy to the device, ensuring, with the use of said flywheel **150** a smooth and constant rotation of the rotor. This results in a stable and permanent electricity generation.



**[0038]** According to some embodiments of the invention the electro-magnetic generator is a generator standard to the art. The electricity generated by this operation is then transferred, using traditional technology and components (i.e. batteries, regulators, DC motors etc), to connected streetlights or any other electric power appliance or holding station. Alternative connectivity method is based on synchronized regulator that enables a direct connection of generated electricity to power grid, via a bi-directional power meter. Using the present system acts as a “power station”, while generated power is credited to the system's owner.

**[0039]** According to some embodiments of the invention, the cover strip **92** encases three layers of material that provide strength and durability, that include rubber, composite material and a thin metal layer. The first layer is thin metallic layer. A second layer made of material that acts as a sound and vibration barrier encloses the steel layer. These two layers are then encased in a composite material. This results in a rigid but flexible material that will withstand wear and heat generated by vehicles constantly riding across it as well as the resultant continuous flexing.

**[0040]** According to some embodiments of the invention the housing and most of the components contained therein are made of metal for robustness.

**[0041]** According to some embodiments of the invention, at its highest point, the cover strip sits approximately 9 cm above the surface of the road. In the arced position, the cover strip is at least 40 cm wide.

**[0042]** The current invention solves the problem of the prior art by first accumulating rotation by the flywheel, until a steady rotation rate is achieved, and only then electricity generation is initiated, and electricity is generated from the additional incoming rotations, while keeping the flywheel turning at an approximately constant rate. This way produces a relatively steady output current that can be effectively used and stored.

**[0043]** Demand for alternative energy resources is ever-growing due to rising fossil fuel costs and environmental influences of energy production. The current invention extracts energy from moving vehicles, and so regenerates some of the braking energy of the vehicles. In view of the large and growing number of wheeled vehicles, braking energy regeneration is becoming an important alternative source of energy. The invention further provides a local energy source for road related devices. This

provision spares remote electricity generation and also allows electricity supply on demand – in relation to traffic density.

**[0044]** In the above description, an embodiment is an example or implementation of the invention. The various appearances of "one embodiment", "an embodiment" or "some embodiments" do not necessarily all refer to the same embodiments.

**[0045]** Although various features of the invention may be described in the context of a single embodiment, the features may also be provided separately or in any suitable combination. Conversely, although the invention may be described herein in the context of separate embodiments for clarity, the invention may also be implemented in a single embodiment.

**[0046]** Furthermore, it is to be understood that the invention can be carried out or practiced in various ways and that the invention can be implemented in embodiments other than the ones outlined in the description above.

**[0047]** The invention is not limited to those diagrams or to the corresponding descriptions. For example, flow need not move through each illustrated box or state, or in exactly the same order as illustrated and described.

**[0048]** Meanings of technical and scientific terms used herein are to be commonly understood as by one of ordinary skill in the art to which the invention belongs, unless otherwise defined.

**[0049]** While the invention has been described with respect to a limited number of embodiments, these should not be construed as limitations on the scope of the invention, but rather as exemplifications of some of the preferred embodiments. Other possible variations, modifications, and applications are also within the scope of the invention.

## CLAIMS

What is claimed is:

1. A system for electricity generation from a plurality of wheeled vehicles moving along a road, the system comprising:

a flap, hingedly connected at a first end at a road level to a frame, and having two states: (i) a protruding state, in which the flap is inclined upwards and a second end of the flap is above road level, and (ii) a level state, in which the flap is on a level with the road, wherein the flap is arranged to be moved from the protruding state to the level state by vehicles moving across the flap and pushing down the second end of the flap,

a rack and a pinion, the rack being vertical and jointedly connected by a bar to the second end of the flap, and the pinion being mounted on an input axis and arranged to turn upon vertical movement of the rack due to the vertical pushing down of the second end of the flap by passing vehicles,

a transmission connected to the input axis and arranged to transmit only rotations thereof due to downward movements of the rack to an output axis, and de-couple the input axis from the output axis upon rotations of the former resulting from upward movements of the rack, to accumulate rotations in one direction, and

a flywheel connected to the output axis and arranged to receive the transmitted rotations from the transmission, and operate an alternator over a belt to produce electricity from the accumulated rotation of the flywheel.

2. The system of claim 1, positioned within a frame below road level.

3. The system of claim 1, wherein the transmission comprises a gear arranged to maintain the rotation of the flywheel within a specified range.

4. The system of claim 1, wherein the flap comprises an extension hingedly connected to the second end to yield a bump like protrusion in the road.

5. Two systems of claim 1, positioned back to back to generate electricity from two-way traffic.

6. A method of electricity generation from a plurality of wheeled vehicles moving along a road, comprising:

positioning a hinged protruding flap arranged to generate linear motion of an attached rack upon depression of the flap by a passing vehicle,

converting the linear motion of the rack to a rotational motion of an axis by enabling rotation of the axis in one direction only,

regulating accumulated rotational motion to a specified range of rotation speeds,  
and

producing electricity from the regulated rotational motion.

7. The method of claim 6, wherein the conversion of linear to rotational motion is carried out by a rack and pinion.

8. The method of claim 7, wherein the enabling rotation of the axis in one direction only is carried out by a transmission arranged to decouple two parts of the axis during an upwards motion of the rack, one part attached to the pinion the other part accumulating rotation the enabled direction.

9. The method of claim 6, further comprising positioning flaps in two traffic directions to generate electricity from two-way traffic.

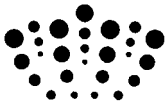

**Application No:** GB1108067.8

**Examiner:** Mr Charles Jarman

**Claims searched:** 1-9

**Date of search:** 13 July 2011

**Patents Act 1977: Search Report under Section 17**

**Documents considered to be relevant:**

Category	Relevant to claims	Identity of document and passage or figure of particular relevance
X	1-9	GB1332202 A (PEDRICK) See e.g. figure 1 and page 2, lines 28-38 particularly.
X	1-9	US2002/0089309 A1 (KENNEY) See whole document.
X	1-9	WO86/07504 A1 (CANONICA) See whole document.
X	1-3, 5-9	US2004/0160058 A1 (GOTT ET AL.) See lines 1-2 of paragraph 24 particularly.
X	1-3, 5-9	KR1020090099117 A (KIM KYOUNG TECK) See whole document.
A	-	WO2008/035348 A2 (INNOVATIVE PATENTS LTD.) See whole document.

**Categories:**

X	Document indicating lack of novelty or inventive step	A	Document indicating technological background and/or state of the art.
Y	Document indicating lack of inventive step if combined with one or more other documents of same category.	P	Document published on or after the declared priority date but before the filing date of this invention.
&	Member of the same patent family	E	Patent document published on or after, but with priority date earlier than, the filing date of this application.

**Field of Search:**

Search of GB, EP, WO & US patent documents classified in the following areas of the UKC<sup>X</sup> :

Worldwide search of patent documents classified in the following areas of the IPC

E01F; F03G; H02K

The following online and other databases have been used in the preparation of this search report

WPI, EPODOC

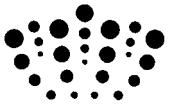

**International Classification:**

<b>Subclass</b>	<b>Subgroup</b>	<b>Valid From</b>
F03G	0007/08	01/01/2006
E01F	0009/047	01/01/2006
H02K	0007/18	01/01/2006