

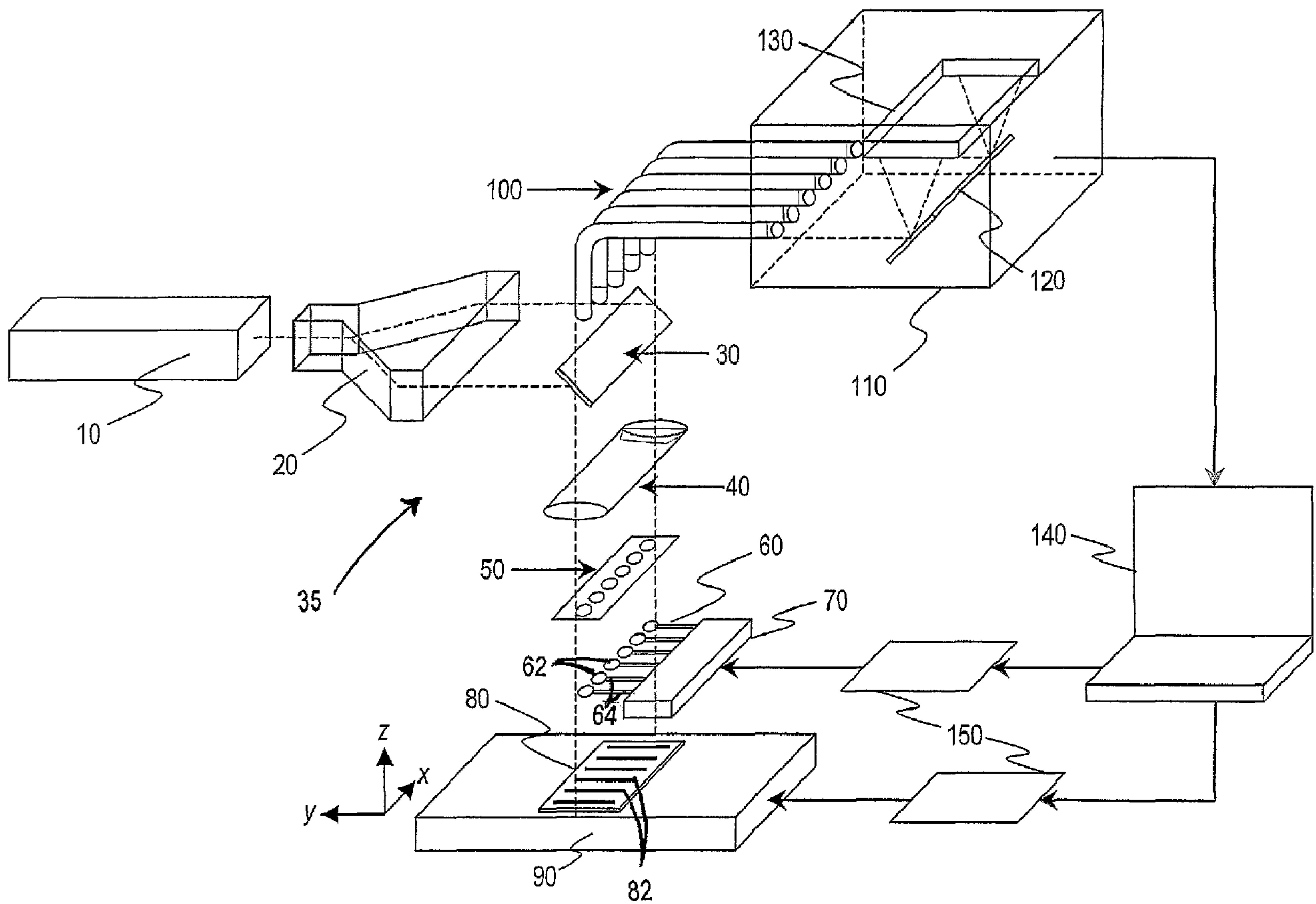

(86) Date de dépôt PCT/PCT Filing Date: 2004/04/05  
 (87) Date publication PCT/PCT Publication Date: 2004/10/21  
 (45) Date de délivrance/Issue Date: 2012/09/18  
 (85) Entrée phase nationale/National Entry: 2005/09/29  
 (86) N° demande PCT/PCT Application No.: US 2004/010544  
 (87) N° publication PCT/PCT Publication No.: 2004/090505  
 (30) Priorité/Priority: 2003/04/04 (US60/460,702)

(51) Cl.Int./Int.Cl. *G01J 3/44* (2006.01),  
*G01N 21/65* (2006.01)  
 (72) Inventeur/Inventor:  
POPONIN, VLADIMIR, US  
 (73) Propriétaire/Owner:  
VP HOLDING, LLC, US  
 (74) Agent: GOWLING LAFLEUR HENDERSON LLP

(54) Titre : PROCÉDE ET APPAREIL DE BALAYAGE NANO-SPECTROSCOPIQUE AMELIORE  
 (54) Title: METHOD AND APPARATUS FOR ENHANCED NANO-SPECTROSCOPIC SCANNING



(57) Abrégé/Abstract:  
 Apparatus and method for examining the identity of chemical groups in a sample (82) are disclosed. The apparatus (35) has a substrate (80) having a plasmon resonant surface on which the sample (82) is supported, a source of a beam of light (10), and a



(57) **Abrégé(suite)/Abstract(continued):**

lens assembly (60) having a tip region and a nanolens (62) composed of one or more plasmon resonance particles (PRPs) on the tip region. The PRPs are arranged to produce near-field electromagnetic gap modes in a space between the nanolens (62) and a confronting detection region on the substrate surface (80) when the gap between the nanolens (62) and the substrate (80) is 30 nm or less. A focusing mechanism in the apparatus operates to move the lens assembly (60) toward and away from the substrate surface (80), with a gap of less than 30 nm, to produce electromagnetic gap modes that enhance the Raman spectroscopy signals produced by the sample (82) in the detection region.

## (12) INTERNATIONAL APPLICATION PUBLISHED UNDER THE PATENT COOPERATION TREATY (PCT)

(19) World Intellectual Property  
Organization  
International Bureau



(43) International Publication Date  
21 October 2004 (21.10.2004)

PCT

(10) International Publication Number  
**WO 2004/090505 A3**

- (51) International Patent Classification<sup>7</sup>: **G01J 3/44**, (74) Agents: **DEHLINGER, Peter, J.** et al.; Perkins Coie LLP, P.O. Box 2168, Menlo Park, CA 94026 (US).  
G01N 21/65
- (21) International Application Number: PCT/US2004/010544
- (22) International Filing Date: 5 April 2004 (05.04.2004)
- (25) Filing Language: English
- (26) Publication Language: English
- (30) Priority Data: 60/460,702 4 April 2003 (04.04.2003) US
- (71) Applicant (for all designated States except US): **INTERNATIONAL FRONTIER SCIENCE ORGANIZATION** [US/US]; 1890 Sutter Street, #204, San Francisco, CA 94115 (US).
- (72) Inventor; and
- (75) Inventor/Applicant (for US only): **POPONIN, Vladimir** [US/US]; 1890 Sutter Street, #204, San Francisco, CA 94115 (US).
- (81) Designated States (unless otherwise indicated, for every kind of national protection available): AE, AG, AL, AM, AT, AU, AZ, BA, BB, BG, BR, BW, BY, BZ, CA, CH, CN, CO, CR, CU, CZ, DE, DK, DM, DZ, EC, EE, EG, ES, FI, GB, GD, GE, GH, GM, HR, HU, ID, IL, IN, IS, JP, KE, KG, KP, KR, KZ, LC, LK, LR, LS, LT, LU, LV, MA, MD, MG, MK, MN, MW, MX, MZ, NA, NI, NO, NZ, OM, PG, PH, PL, PT, RO, RU, SC, SD, SE, SG, SK, SL, SY, TJ, TM, TN, TR, TT, TZ, UA, UG, US, UZ, VC, VN, YU, ZA, ZM, ZW.
- (84) Designated States (unless otherwise indicated, for every kind of regional protection available): ARIPO (BW, GH, GM, KE, LS, MW, MZ, SD, SL, SZ, TZ, UG, ZM, ZW), Eurasian (AM, AZ, BY, KG, KZ, MD, RU, TJ, TM), European (AT, BE, BG, CH, CY, CZ, DE, DK, EE, ES, FI, FR, GB, GR, HU, IE, IT, LU, MC, NL, PL, PT, RO, SE, SI, SK, TR), OAPI (BF, BJ, CF, CG, CI, CM, GA, GN, GQ, GW, ML, MR, NE, SN, TD, TG).
- Published:  
— with international search report

[Continued on next page]

(54) Title: METHOD AND APPARATUS FOR ENHANCED NANO-SPECTROSCOPIC SCANNING

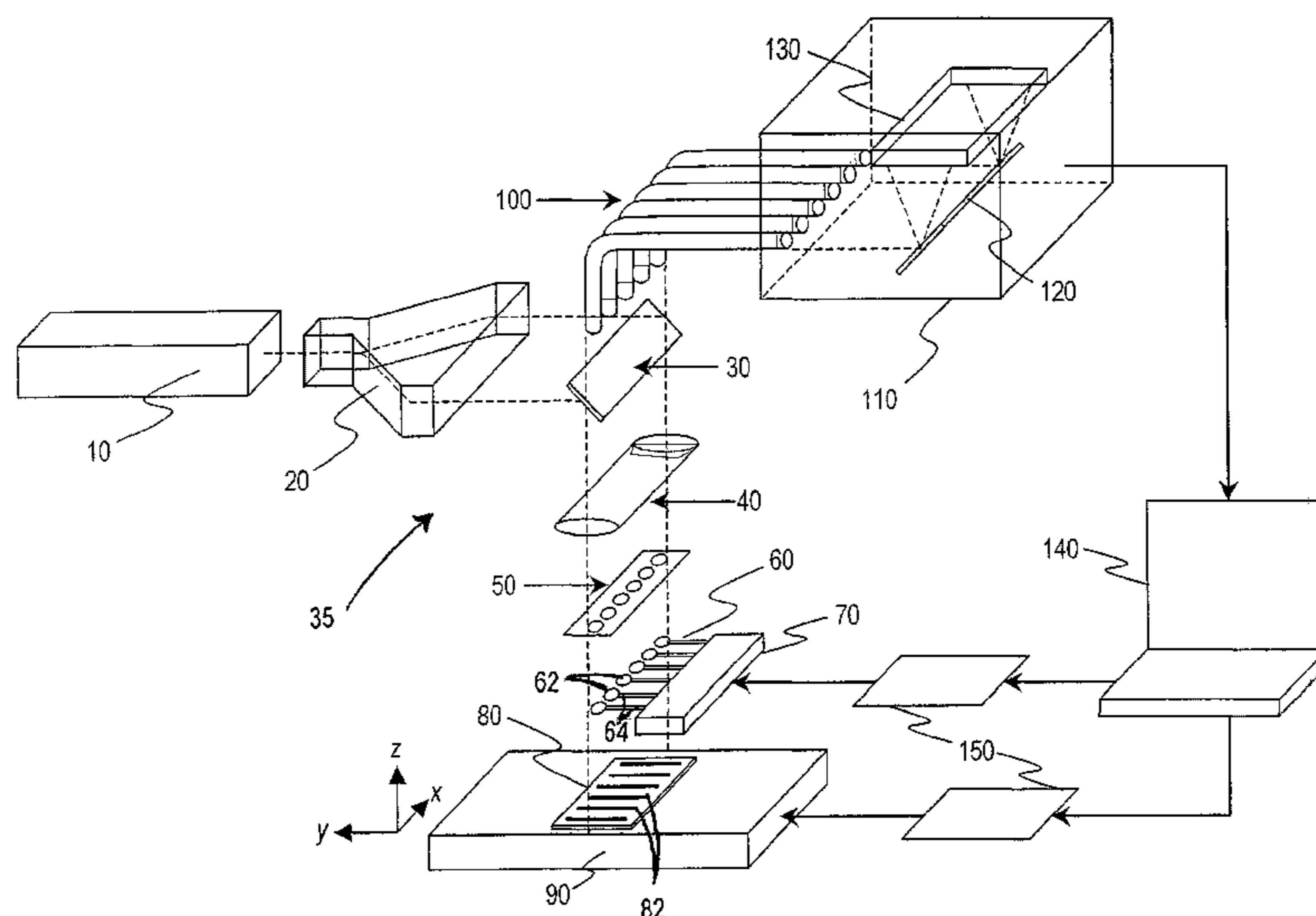

(57) Abstract: Apparatus and method for examining the identity of chemical groups in a sample (82) are disclosed. The apparatus (35) has a substrate (80) having a plasmon resonant surface on which the sample (82) is supported, a source of a beam of light (10), and a lens assembly (60) having a tip region and a nanolens (62) composed of one or more plasmon resonance particles (PRPs) on the tip region. The PRPs are arranged to produce near-field electromagnetic gap modes in a space between the nanolens (62) and a confronting detection region on the substrate surface (80) when the gap between the nanolens (62) and the substrate (80) is 30 nm or less. A focusing mechanism in the apparatus operates to move the lens assembly (60) toward and away from the substrate surface (80), with a gap of less than 30 nm, to produce electromagnetic gap modes that enhance the Raman spectroscopy signals produced by the sample (82) in the detection region.

WO 2004/090505 A3

**WO 2004/090505 A3**



— *before the expiration of the time limit for amending the claims and to be republished in the event of receipt of amendments*

*For two-letter codes and other abbreviations, refer to the "Guidance Notes on Codes and Abbreviations" appearing at the beginning of each regular issue of the PCT Gazette.*

**(88) Date of publication of the international search report:**  
24 February 2005

METHOD AND APPARATUS FOR ENHANCED  
NANO-SPECTROSCOPIC SCANNING

Field of the Invention

- 5 The present invention relates to the field of nano-spectroscopic scanning, and in particular, to a method and apparatus capable of spectroscopic identification of single-molecule or single-chemical group structures carried on a substrate.

References

- 10 The references below are cited as part of the background of the invention and/or as providing methodologies that may be applied to certain aspects of the present invention.
- G.R. Brewer, Electron-Beam Technology in Microelectronic Fabrication, Academic Press, NY, 1980).
- 15 David Ginger et al., "The evolution of Dip-Pen Nanolithography", Angew. Chem. Int. Ed. ,v. 43, p. 30-45, 2004).
- S. Hayashi, "Spectroscopy of Gap Modes in Meta Particle-Surface Systems," Topics Appl Phys 81:71-95 (2001).
- I-K. Kneipp et al. "Ultrasensitive Chemical Analyses by Raman Spectroscopy", Chem. Rev., 1999, vol. 99, p. 2957-2975, see p. 271).
- 20 V. Matyushin, A et al., "Tuning the setup of sputter-coated multilayers in nanocluster-based signal enhancing biochips for optimal performance in protein and DNA-assays" J. Nanoscience and Nanotechnology Volume 4, Number 1/2 (January/February 2004), pp.98-105 (2004)
- 25 D. McCamant, "Femtosecond Broadband Stimulated Raman: A new Approach for High-Performance Vibrational Spectroscopy", Applied Spectroscopy, Vol. 57, p. 1317-1323, 2003.
- S.C. Minne et. al., "Automated parallel high-speed atomic force microscopy", Applied Physics Letters, Vol. 72, p. 2340-2342, 1998.
- 30 S.C.Minne et al., "Bringing Scanning Probe Microscopy up to Speed", 173 p. Kluwer Academic Publishers, 1999.

C. M. Niemeyer, "Self-assembled nanostructures based on DNA: towards the development of nanobiotechnology", Current Opinion in Chemical Biology, v. 4, p. 609-618, 2000.

J.P. Rabe. "Self-assembly of single macromolecules at surfaces". Current  
5 Opinion in Colloid and Interface," Science. Vol. 3, p. 27-31, 1998

F. Wolf et al., Review of Scientific Instruments, 1999, Vol. 70, p. 2751-2757, "Novel Scanning Near-Field Optical Microscope (SNOM)/scanning confocal optical microscope based on normal force distance regulation and bent etched fiber tips."

10 Y. Xia et al., Advanced Functional Materials, v. 13, p. 907-918, 2003  
"Template-assisted Self-Assembly of Spherical Colloids into Complex and Controllable Structures"

H. Xu et al. Phys Rev E, v. 62, p. 4318, 2000.

F. Zenhausen, et al., "Scanning Interferometric Apertureless Microscopy:  
15 Optical Imaging at 10 Angstrom Resolution", Aug. 25, 1995, Science, Vol. 269.

#### Background of the Invention

A variety of tools and methods exist for examining surface features and structure at the microscale and even nanoscale level. Scanning atomic force  
20 microscopy (AFM) allows for mapping surface topology at a microscale level by moving a detector tip carried at the free end of a cantilever beam over or across the surface of the material being mapped. This type of microscope may operate by direct physical contact with the surface or, in a tunneling mode, by detection of a tunneling current when the tip is a selected distance from the surface. This  
25 type of device has proven very useful for mapping surface topography, e.g., for detecting imperfections in integrated-circuit chips, but is not designed or can be operated to detect specific chemical compounds or chemical groups. This concept has been extended to parallel-high-speed AFM (e.g., Minne, 1998; 1999).

30 The scanning tip approach has also been adapted for optical detection of mapping of a surface. U.S. Patent No. 6,441,359, for example, describes a near-field optical scanning system in which near-field optics is carried at the free

end of a cantilever beam. The patent also discloses microfabrication methods for constructing an array of such optical elements for an optical scanning system. The tip to sample distance in the apparatus is controlled by an optical level deflection system that acts to maintain the tip close to the sample surface. The system is able to achieve sub-wavelength resolution by scanning an aperture of sub-wavelength dimensions or by scanning the solid immersion lens very close to the sample. The device is not designed nor could it be used to detect individual chemical molecules or groups, due to the very low signal level of signal that would be produced. Scanning near-field optical microscopes (SNOM) have been proposed by others (e.g., Wolf).

One very sensitive probe for chemical analysis is surface-enhanced Raman spectroscopy or SERS (see, for example Kneipp). In addition SERS has been applied to a high-resolution scanning microscope for purposes of achieving high-resolution spectroscopic information from a sample surface, e.g., U.S. Patent No. 6,002,471. The device includes a small conductive element (a plasmon resonance particle or PRP) at the free tip of a scanning cantilever beam, to enhance the light emitted in the vicinity of the probe. The sample substrate is formed of glass. The patent does not show or suggest methods for exploiting electromagnetic gap modes to enhance spectroscopic resolution that is likely for resolving single chemical structures, such as DNA bases, nor does the patent show or suggest a system capable of reading a plurality of samples, e.g., stretch DNA strands, in parallel.

### Summary of the invention

In one aspect, the invention includes an apparatus for examining the identity of chemical groups in a sample attached to a surface. The apparatus has a plasmon resonant substrate, i.e., a substrate having a mirror surface on which the sample is supported, a source of a beam of light, preferably coherent light, and a lens assembly having a tip region and a nanolens composed of one or more plasmon resonance particles (PRPs). The PRPs are arranged on the tip region to produce, when the light beam is directed through the nanolens, near-field electromagnetic gap modes in a space between the nanolens and a

confronting detection region on the substrate surface, in a gap between the nanolens and substrate that is 40 nm or less.

A focusing mechanism in the apparatus, such as a piezo-electric drive, is operable to move the lens assembly toward and away from the substrate surface, with a gap therebetween of less than 40 nm, to produce electromagnetic gap modes that enhance the Raman spectroscopy signals produced by the sample in the detection region. Light emitted by or scattered from the sample at the detection region is received at a detector, which converts the received light into a characteristic Raman spectrum, whereby the sample chemical group at the detection region can be identified. The apparatus may include a translation mechanism, such as a piezoelectric drive, for translating the lens assembly relative to the substrate, to position the lens assembly over different detection regions of the substrate.

The nanolens in the assembly preferably includes at least said three PRPs arranged symmetrically about a central axis normal to the plane of the substrate surface, with each PRP being less than 50-200 nm in its largest dimension, and the distance across any pair of PRPs being substantially less than the wavelength of the light beam. The PRPs may be spherical, or ellipsoidal and arranged with their major axes oriented to intersect the central axis. The light source in this embodiment may produce a beam of circularly polarized light, preferably coherent light, whose plane of polarization is normal to the central axis.

The lens assembly may include a cantilever beam having a tip region at its free end, with the focusing mechanism being operatively coupled to the beam. The mechanism is preferably operable to bring the nanolens to a selected distance between 0.1 and 5 nm of the substrate surface.

For use in sequencing a linear strand of nucleic acid, by successively examining the bases (chemical groups) of the nucleic acid strand, the substrate includes molecular anchors for holding the nucleic acid strand in a stretched linear condition, and the translation mechanism is operable to move the lens assembly along the length of the strand, for examining and identifying each base of the strand sequentially. For examining a plurality of substantially nucleic acid

samples simultaneous, the apparatus provides a plurality of linearly aligned cantilever lens assemblies, each of whose position toward and away from the substrate surface can be individually controlled by a corresponding focusing mechanism associated with each lens assembly, and which are translated as a unit by a single translation mechanism.

In another aspect, the method includes a method for examining the identity of chemical groups in a sample. After attaching the sample to a substrate having a plasmon resonant mirror surface, a beam of light is directed onto the sample through a nanolens in a lens assembly of the type described above, to produce near-field electromagnetic gap modes in a space between the nanolens and a confronting detection region on the substrate surface, when the gap between the nanolens and substrate is 40 nm or less. The lens assembly is moved toward or away from the substrate surface, with a spacing between the nanolens and substrate surface of less than 40 nm, to produce electromagnetic gap modes that enhance the Raman spectroscopy signals produced by the sample in the detection region. The light emitted by or scattered from the sample at the detection region is received by a detector and converted to a Raman spectrum that is characteristic of the chemical group being interrogated, whereby the sample chemical group at the detection region can be identified.

The position of the lens assembly may be controlled to bring the nanolens to a selected gap distance between 0.1 and 5 nm of the substrate surface. The nanolens may be composed of at least three PRPs arranged symmetrically about a central axis that is normal to the plane of the substrate surface, each particle is less than 50-200 nm in its largest dimension, and the distance across any pair of particles is substantially less than the wavelength of the light beam. The light directed onto the lens is preferably a beam of circularly polarized light whose plane of polarization is normal to the central axis.

For use in sequencing a linear strand of nucleic acid, the sample may be attached to the substrate surface by stretching the strand linearly, and anchoring opposite end portions of the strands to the substrate. The method further includes translating the lens assembly with respect to the sample on the substrate, to position the nanolens adjacent successive chemical-group bases in

the strand. For use in sequencing a plurality of linear strands of nucleic acid samples, the plural strands are stretched and anchored on the substrate in a parallel array. A plurality of such lens assemblies, e.g., an array of cantilever beams is then translated with respect to the array of DNA strands, to position the associated nanolenses adjacent successive chemical-group bases in each of the  
5 strands.

These and other objects and features of the invention will be more fully understood when the following detailed description of the invention is read in conjunction with the accompanying drawings.

10

#### Brief Description of the Drawings

Fig. 1 shows the arrangement of components in an apparatus constructed according to one embodiment of the invention;

Fig. 2a illustrates electromagnetic phenomena resulting in near-field  
15 electromagnetic gap modes by directing a circularly polarized light beam onto a nanolens constructed according to one embodiment of the invention having a six-particle nanolens, and Fig. 2b shows nanolenses formed of between 2 and 6 PRPs;

Figs. 3a and 3b shows in perspective (3a) and cross-sectional (3b) views,  
20 an end region of a cantilever beam having an integrated nanolens, in accordance with the invention;

Fig. 4 shows a substrate having an array of stretched DNA strands anchored on its upper surface;

Figs. 5a and 5 b illustrate in perspective (5a) and sectional view (5b), the  
25 optical phenomena exploited in the present invention for detecting successive individual bases in a stretched DNA sample;

Figs. 6a, 6b, and 6c show results of numerical simulation of three edge star silver nanolens. Fig 6a shows frequency dependence of field amplitude in the center of nanolens, corresponding to plasmon resonance at 2.45 eV; Fig. 6b  
30 shows field distribution along y axis; and Fig. 6c shows a topographic view of the field distribution as seen from the top;

Figs. 7a, 7b, and 7c are like Figs. 6a-6c, respectively, but show results of numerical simulation of a four edge star silver nanolens;

Fig. 8 shows distribution of field in a four edge star nanolens along x axis, showing a maximum amplification of 3000 near the surface of PRP.

5

## Detailed Description of the Invention

### I. Definitions

The terms below have the following meaning, unless otherwise indicated  
“Plasmon resonant metal” includes any metal, such as gold, silver, or aluminum  
10 which can support surface electromagnetic modes –surface plasmon polaritons  
(SPP), which are coupled modes of photons and plasmons.

“Chemical group” in a sample may include subunits in a polymer, or  
subunit moieties, such as nucleic acid bases, or chemical substituent groups,  
such as hydroxyl, amine, alkyl, acid, or aldehyde groups. Such chemical groups  
15 are characterized by a unique enhanced Raman spectral signatures or features.

“Gap modes” refers to electromagnetic normal modes or electromagnetic  
eigenmodes that are excited by external electromagnetic field in a space  
between two or more plasmon resonance particles and when plasmon  
resonance particles are placed near (less than 40 nm) from a metal surface,  
20 preferably a plasmon resonant metal surface. Examples of plasmon resonance  
particles are silver or gold particles having their largest dimension typically in the  
5 nm to 200 nm size range.

“Gap-mode enhanced Raman spectrum” of a sample refers to spectral  
features in a Raman spectrum of the sample that are enhanced by the presence  
25 of gap modes at the sample.

### B. Apparatus for nano-spectroscopic scanning

Fig. 1 shows an apparatus, indicated generally at **35**, for examining the  
identity of chemical groups in a sample attached to a surface. Shown in the  
30 figure is a scanning stage **90**, and carried on the stage, a DNA chip **80** having a  
plurality of stretched DNA strands, such as strands **82** anchored on the chip  
surface and disposed parallel to one another. Methods for anchoring stretch

polymer strands, such as DNA strands on a chip surface will be described below. According to an important feature in this embodiment, the surface of the chip on which the sample is supported has a mirror coating of a plasmon resonance metal, e.g., silver, gold, or aluminum.

5 The DNA strands are scanned by scanning stage **90** such as a piezoelectric, or electromagnetic motion control stage. A stage with electromagnetic motion control allows a scan area up to tens of centimeters and more, thus allowing scanning single molecule DNA chips with total individual chromosomes.

10 A light beam with preferably coherent, circularly polarization is generated by a laser **10**. The laser may include two lasers for performing nonlinear Raman spectroscopy such as CARS and Femtosecond Induced Raman Spectroscopy (D. McCamant). An exemplary laser system uses a Ti-Sapphire tunable laser with pulsed and continuous mode of operation. The wavelength of excitation  
15 light beam preferably is selected and tuned to be in close proximity to the maximum spectral peak in the plasmon resonance absorption spectra of the plasmon resonant substrate. In case scanning with of plasmon nanolens plasmon resonance absorption spectra of whole system (plasmon nanolens + plasmon resonant substrate) should be considered in adjustment of frequency. It  
20 is important to note that because of nanoscopic proximity of plasmon nanolens to surface of plasmon resonant substrate spectra of plasmon absorption are changed.

The light beam is expanded by means of beam expander, or is transformed into scanning beam in a beam raster **20**. In this way, a single light  
25 beam is split into an array of light beams each directed into individual plasmon nanolens in array of nanolens **60**. Each individual light beam is directed through a beam splitter **30** and collimation optics **40** onto a microlens array **50**. The microlens array allows individual digital control of each individual light beam directed into individual plasmon nanolenses, such as lenses **62** in array **60**,  
30 carried at the free end of cantilever beams, such as beam **64**, as will be described in greater detail below.

As will be appreciated below, the plasmon gap mode nanolens disclosed in the present invention is based on the ability of localized plasmons (collective oscillations of electrons) excited inside metal nanoparticles by external electromagnetic wave to enhance electromagnetic fields in a near-field zone in close proximity to a plasmon resonance surface and to localize it in extremely small nanoscale volumes. This non-propagating electromagnetic field is concentrated in close proximity (few tens of nanometers 30-40 nm) near nanoparticle surfaces and is named as "near field electromagnetic field" to distinguish it from propagating electromagnetic field in far field zones.

10 With continued reference to Fig. 1, the light beam applied to each plasmon nanolens in the cantilever-beam array may be modulated by a micromachined mirror assembly 50 such as sold by Texas Instruments, Inc., Dallas, Texas, under the tradename "Digital Micromirror Device". This system allows digital control of each individual plasmon nanolens illumination and read out signal scattered from each plasmon nanolens. This system is especially useful for implementing of digital control of high speed programmed individually addressable multichannel pulsed mode illumination and acquisition of scattered signal that is crucial for implementing ultra rapid direct DNA sequencing with direct digitizing of sequence information into computer memory.

20 The distance between the plasmon nanolens and sample DNA is maintained by a feedback cantilever bending system. Such control systems are well known and described for atomic force microscopes, e.g., in U.S. Patent No. 5,883,705, or near field scanning optical microscopes, e.g., in U.S. Patent No. 5,354,985. One method for 25 of individual actuation and control of each cantilever beam in array 60 during a scanning process employs piezo-resistor feedback control, as disclosed detail in the US Patent No. 6,441,359.

The distance between each plasmon nanolens and the associated DNA sample is preferably maintained at the level of 0.1 nm to few nanometers in order to achieve optimum field amplification and localization in gap between nanolens and DNA sample and surface of substrate by excitation of near field electromagnetic gap modes as it shown on Fig. 2 and 6a and 6b. As the gap

between each nanolens and the substrate surface on which the sample is carried varies, the localization and intensity of electromagnetic gap modes varies also. Therefore, by changing the distance between nanolens and DNA sample (or substrate surface) it is possible to control the shape and localization of  
5 electromagnetic gap modes, for the purpose of achieving maximum scattered light (read out) signal and maximum spatial resolution. By optimizing these gap modes, it is possible to achieve a level of resolution that allows discrimination between individual bases in a DNA strand immobilized on the surface of the  
10 substrate. Depending on the level of overstretching of the DNA strands on a chip, the requirements for spatial resolution may vary from base to base, and from strand to strand. However, the distance is in a range of a few nanometers to less than 1 nanometer.

In the embodiment shown in Fig. 1, light reflected in backscattering geometry from each plasmon nanolens interacting with individual DNA bases is  
15 directed back through microlens array **50**, collimation optics **40**, and a beam splitter **30** into receiving end of optical fiber ribbon **100**. It will be understood, however, that the invention is not limited to backscattering collection of light. In other implementations of invention illumination and collection geometry may be other from backscattering geometry, in which case light illumination and  
20 collection optical systems may be separated.

Scattered signal light through optical fiber ribbon **100** is directed onto the slit of a monochromator of a multichannel spectral analyzer **110**. Notch filters are employed to eliminate incident light. A diffraction grating **120** splits scattered light beam into set of monochromatic light beams that will be transformed into  
25 individual Raman spectra. Spectra obtained on detector array **130** are then converted into digital form and transmitted into computer **140** where they are processed to produce sequence information of DNA samples on the chip. Another suitable optical design, not shown here, utilizes interferometric detection method, such as has been previously disclosed (e.g., F. Zenhausen).

### C. Nanolens operation and fabrication

This section describes specific nanolens structures designed to be placed in close proximity to the smooth metallic surface of the sample substrate, to produce localized gap modes when the lens is illuminated by a light beam, e.g., a coherent and/or circularly polarized light beam. These modes can be used for direct optical reading of molecules, placed in a space between the nanolens of mirror substrate surface, with high spatial resolution for achieving sub-nanometer resolution, and with signal amplification allowing detection of spectral signature of single small molecule such as individual bases of DNA strands.

The most general design of a nanolens includes one and preferably a plurality (e.g., 2-6) metal nanoparticles having selected shapes and selected particle geometries with respect to each other. A preferred particles geometry is a symmetrical arrangement of the particles about a central axis, as will be illustrated below, although other geometries, such as disordered fractal, are also contemplated. The nanoparticles forming the lens may have different shapes and dimensions and are placed in nanoscopic proximity to each other. However the largest dimension of each nanoparticle and of the system as a whole do not exceed the wavelength of the illuminating light. Nanoparticles in the size range between 5-200 nm, e.g., 20-50 nm are preferred.

Fig. 2 is a detailed perspective view of a portion of a cantilever beam **160** carrying a six-particle nanolens **180** at its free (distal) end. As seen, a circularly polarized light beam **190** from laser source is directed through confocal lens optics **50** onto a nanolens **180**. The nanolens is mounted on a holder **170** formed of transparent dielectric material, which could be in one embodiment the free end of cantilever **160** used to controls the distance between a nanolens and the sample in scanning probe device. The nanolens is placed in close proximity to a metal mirror surface **200** on the sample substrate. Since far field light directed by the confocal optics can be focused to a spot size around or slightly less than 1 micron, which is determined by diffraction optics limit, and diameter of the nanolens (the diameter of the circle circumscribing the nanolens particles **182**) is preferably in the range of 50 –200 nm, that is, less than the wavelength

of the illumination light. Also as seen in the figure, the light illumination area (dotted-line circle indicated at **350**) is usually larger than area of nanolens. However, it is possible to create a nanolens of 0.5 –1.0-micron diameter so that it will match focal spot. In that case, the nanolens will work as a nanoantenna, which will concentrate electromagnetic energy to the center of nanolens through excitation of localized plasmons.

In the embodiment shown in Fig. 2a, plasmon nanolens **185** has a star like structure consisting of six metal nanoparticles, such as particles **182**, each particle having a shape of either a prolate spheroid with a large eccentricity (preferably more than 5), or a cylindrical nanorod with hemisphere caps at the ends, or a metal nano wire. This particle geometry is also seen at **185** in Fig. 2B, along with nanolens particle configurations **195**, **205**, **215**, and **225** for lens with five, four, three, and two particles, respectively.

As noted above, illumination of each nanolens is preferably by a laser beam or non-coherent electromagnetic wave with circular polarization. Maximum enhancement of the electromagnetic field, indicated at **200** in Fig. 2a, is achieved in the central part of the lens close to axis of nanolens. This region has diameter of a few nm or less. Field amplification factor up to 1500-3000 may be achieved in the center of nanolens as it is illustrated by results of numerical simulation described below with respect to Figs. 6a-6c, 7a-7c, and 8 8, below. That amplification factor significantly exceeds the amplification achievable in configurations consisting of spherical nanoparticles and other shapes of nanoparticles known from prior art. Maximum local field amplification achieved in numerical simulation of 300 was reported (H. Xu).

The nanolens of the invention may be constructed by a variety of known methods. In general, the nanolens is fabricated integrally with the cantilever beam using established nanofabrication methods based on electron beam lithography or focused ion beam lithography (G.R. Brewer), or based on Scanning Tunneling Microscopy Lithography. Another method of fabrication may be based on template assisted self-assembling (Y. Xia). Alternative methods such as dip-pen nanolithography can be used to create plasmon nanolens patterns on different support materials (e.g., D. Ginger) or DNA based self-

assembling technique (e.g., C. M. Niemeyer). In one embodiment plasmon nanolens may be integrated into at free end of cantilever that is part of scanning probe device, and can simultaneously perform function of cantilever tip that control distance between nanolens and sample during scanning in scanning  
 5 probe devices such as Atomic Force Microscope – AFM or Scanning Near Field Optical Microscope - SNOM. One possible implementation of plasmon nanolens integrated into cantilever of scanning probe spectroscopic device is presented in Fig. 3.

Fig. 3 illustrates how plasmon nanolens may be integrated into a free end  
 10 of cantilever of scanning probe spectroscopic device, and can simultaneously perform the function of a cantilever tip that control distance between the nanolens and sample during scanning of the sample. Cantilever **160** is prepared from a composite material that has an opaque material portion **260** and an optically transparent portion **170** that forms optical window **250**, allowing incident  
 15 circularly polarized light to interact with nanolens **180** and to excite effectively localized plasmas (LP) and gap modes (GM).

#### D. Preparation of sample-containing substrate

The substrate or support in the apparatus is designed to enhance  
 20 electromagnetic field in close proximity to surface, and is coated with a thin film of a plasmon resonant material, such as a silver, gold, or aluminum. Film thickness is preferably between 25-200 nm, e.g., 50 nm. Suitable substrate, e.g., glass substrates can be coated with the metal film by known methods, such as vacuum evaporation or rf sputtering techniques. Exemplary substrate  
 25 coatings and methods of their production are disclosed in US patent 5,611,998 for “Optochemical sensor and method for production,” and in the reference to V. Matyushin.

DNA strands with lengths, for example, from 100 nanometers up to 2.5  
 30 millimeters are placed on a substrate as shown at **82** in Fig. 1. The distance between strands should be in the range of 200 –300 microns and should correspond to the distance between adjacent cantilevers in cantilevers array.

Preferable is distance 250 micron, which correspond to pitch of 250 micron, which is standard pitch in optical-fiber ribbon applications.

Fig. 4 shows an exemplary chip or substrate **80** for use in the apparatus and method of the invention. As shown here, samples of DNA obtained, for example, from genomic DNA, in the form of single-stranded DNA fragments with lengths up to 2.5 millimeters (5 Mbase). The strands, such as indicated at **210** are placed onto surface of slide with plasmon resonant optical enhancement properties **80**. They are placed in an ordered, addressable way. Each end of DNA strand is attached to complimentary oligonucleotide on right/left barcode **220a** and **220b**. The distance between strands should be in the range of 200 – 300 microns and should correspond to the distance between adjacent cantilevers in cantilevers array. Preferable is distance 250 micron, which correspond to a pitch of 250 micron, which is in correspondence with pitch in standard optical-fiber ribbon.

Methods for stretching and orienting linear polymer samples, such as DNA, RNA, nucleic analogs, polypeptides, linear carbohydrates and the like, are known. For example, the opposite ends of the sample polymer, e.g., DNA, can be covalently attached to microspheres, such as latex or glass beads, and the beads are then manipulated by pulsed-laser molecular tweezers until a suitable degree of stretching, and preferably overstretching, is achieved. This approach is illustrated in Fig. 4 which shows microspheres **290a**, **290b** attached to opposite ends of DNA strand **210**. Each sphere is "captured" by a laser beam, such as beams **300a**, **300b**, for manipulating the spheres to stretch and orient the strand for placement on the substrate surface. Once this placement is achieved, end regions of the strand are anchored to the substrate by hybridization with complementary oligonucleotides attached to the bar-code region of the substrate. Methods for capturing and manipulating microspheres in a laser beam are described, for example, in U.S. Patent No. 5,620,857 and in U.S. patent application 20040001371.

In a related approach, the ends of the polymer strand are covalently attached to magnetic beads, or to a solid support and a magnetic bead, and

magnetic field(s) are applied to the bead(s) until an appropriate degree of stretching and strand orientation are achieved. More generally, the opposite ends of a strand may be attached to a pair of relatively moving supports, and the supports positioned until a desired degree of stretching and orientation are  
5 produced, as disclosed, for example, in U.S. Patent No. 6,342,353.

Methods for drawing a charged polymer strand into a linear conformation by electrophoresis in a narrow microchannel are also known.

Once the polymer strands are stretch and oriented for attachment to the  
10 substrate, the sample molecule is anchored on the substrate by any of a number of suitable anchoring methods. As noted above, the substrate may be provided by end-regions oligonucleotides capable of hybridizing to the sequences at end regions of a sample DNA strand. Where the strand is stretched by manipulating particles covalently attached to the strand ends, the substrate may contain  
15 chemical groups or magnetic structure for anchoring the particles to the substrate, with the strand in a stretched condition. One common chemical attachment chemistry for a gold surface is a thiol reagent covalently carried at end regions of the sample strand.

More generally, procedures for preparation of a substrate surface on  
20 which DNA molecules are to be anchored are known to those of skill in the art of DNA hybridization detection methods (See for instance, J.P. Rabe).

#### E. Scanning and detection method

As indicated above, an important application of the apparatus and method  
25 of the invention is in sequencing nucleic-acid samples such as chromosomal or full genomic DNA. This section will describe the operation of the above apparatus and the method of the invention with reference to this particular application, it being understood that the same operation and method will apply to the examination of the chemical groups in any sample.

30 At its simplest, the method is used to examine one or more chemical groups of a single molecule or collection of similar molecules localized at a defined detection region on a substrate. In this application, a single nanolens

carried, for example, at the free end of a cantilever beam is moved toward the sample, e.g., in the distance range less than 10-40 microns, until a maximum enhancement of a distinguishing enhanced Raman spectral feature is observed. Alternatively, the spectral features may be recorded as the nanolens is moved  
5 alternately toward and away from the sample surface, to yield a time-variant spectrum of the sample. Nanolens oscillation in the range of between 0.1 to 10 nm, for example, could be used in generating the time-variant spectrum.

More generally, the method of the invention for examining the identity of chemical groups in a sample, includes the steps of first attaching the sample to a  
10 substrate having a mirror surface on which the sample is supported, and which is formed of a plasmon resonant metal. A beam of light is directed onto a nanolens of the type described above to produce near-field electromagnetic gap modes in a space between the nanolens and a confronting detection region on the substrate surface, when the gap between the nanolens and substrate is 30 nm  
15 or less. The lens assembly is then moved toward or away from the substrate surface, with a spacing between the nanolens and substrate surface of less than 40 nm, to produce electromagnetic gap modes that enhance the Raman spectroscopy signals produced by the sample in the detection region. Light emitted by or scattered from the sample at the detection region is received by a  
20 detected and converted into a gap-mode enhanced Raman spectrum, whereby the sample chemical group at the detection region can be identified.

Where the sample contains a plurality of groups arranged along a linear portion of the sample molecules, as in the case of a nucleic sample for identification of successive base groups, the procedure just described is applied  
25 to each base successively, as the nanolens is moved relative to the substrate. This movement may be carried out by cantilever translation relative to a stationary substrate or substrate stage movement relative to a stationary nanolens. As the nanolens is placed at each successive position, it is then moved toward or away from the sample to find the optimal detection distance, or  
30 to generate a time-variant spectrum, as described above. The lens and sample bases may be kept in registry by one of a variety of registration techniques. For example, a "control" nanolens could track the detect bases in a known-sequence

DNA sample carried on the substrate. By tracking this sequence, along with one or more unknown-sequence samples, the apparatus can confirm that the relative movement between lenses and substrate is acting to preserve registration between sample and successive DNA bases. Alternatively, one of the cantilever  
5 beams in the apparatus may be a scanning atomic-force microscope tip for detecting movement of the tip over each base of a control DNA strand, as the array of cantilever devices are moved along the DNA strands.

In a more usual application, a plurality of linear sample strands, e.g., DNA strands are aligned on a single substrate, for simultaneous reading by a plurality  
10 of nanolenses, as illustrated at **82** in the apparatus of Fig. 1. Figs. 5a and 5b illustrate this operation as applied to reading a plurality of stretched, aligned DNA strands, such as strand **210**, carried on a substrate **310**. Although the figures show a single lens assembly composed of a cantilever beam **160** carrying a nanolens **180** at its free end, it will be understood that the apparatus includes an  
15 array of lens assembly, one for each of the aligned strands on the substrate.

As the group of lens assemblies are moved along the substrate, each lens assembly is adjusted vertically (in a direction toward the substrate) to optimize spectral signal. As seen in Fig. 5b, this vertical movement is effective to place the gap modes produced by the concentration of near-field electromagnetic  
20 modes between the lens, formed by PRPs such as at **185**, with the plasmon resonant surface, indicated at **310**.

The enhanced Raman spectra of each strand chemical group (base) are consecutively measured using a multichannel Raman spectrograph and are digitized by means of two-dimensional ICCD array with digital recording. The  
25 signal from the Raman spectrometer is stored in computer memory for further analysis. The final results are obtained in a form of sequence of bases of nucleotides A,T,G,C. In a course of scanning procedure nanolens- tip will detect each base (A,T,G,C) in DNA strands both spectroscopic and topographically.

SERS spectra are registered consecutively for each base which will allow  
30 identifying each particular base (A,T,G,C) in DNA strand by its unique enhance spectral signature that is characteristic of that base, allowing direct *de novo* sequencing of individual fragments of DNA molecule. SERS spectra of A, T, G,

and C obtained on plasmon resonant substrate are known to give distinctive spectra that allow for the different bases to be identified. The present invention, by focusing the excitation field in a small gap between a lens and substrate, and exploiting gap-mode enhancement of the Raman signals, allows individual bases  
5 of DNA to be identified, thus permitting direct base-by-base DNA reading.

The numbers of cantilevers with fiber optic tips which can be used in array, are in principle unlimited; however, for one scan sequencing of the largest human chromosome (human chromosome No 1 containing about 263 million bases), the apparatus would require about 100 lens assemblies, each reading a  
10 fragment of about 2.5 – 3.0 Mbase. Assuming 0.01 sec sampling time, the apparatus would complete sequence of this chromosome in less than about 10 hour of scan time. Using this device practically it is possible to implement in parallel up to few hundred channels in array (1DNA strands per channel) with sampling speed of 0.01 to 1 second per base.

15 More generally, the method of the invention for examining the identity of chemical groups in a sample, includes the steps of first attaching the sample to a substrate having a mirror surface on which the sample is supported, and which is formed of a plasmon resonant metal. A beam of light is directed onto a nanolens of the type described above to produce near-field electromagnetic gap modes in  
20 a space between the nanolens and a confronting detection region on the substrate surface, when the gap between the nanolens and substrate is 4 nm or less. The lens assembly is then moved toward or away from the substrate surface, with a spacing between the nanolens and substrate surface of less than 40 nm, to produce electromagnetic gap modes that enhance the Raman  
25 spectroscopy signals produced by the sample in the detection region. Light emitted by or scattered from the sample at the detection region is received by a detector and converted into a gap-mode enhanced Raman spectrum, whereby the sample chemical group at the detection region can be identified.

The degree of Raman spectra amplification achievable with the present  
30 invention can be appreciated from Figs. 6-8. In these figures, electromagnetic field strength  $E$  was calculated by modeling the system and solving Maxwell's equations in a near-field approximation using an integral equation approximation.

Fig. 6a shows the variation in E as a function of eV for a three-particle lens. The field distribution in the central region of the lens is shown in Fig. 6C. Fig. 6b is a plot of field strength taken along the y axis in Fig. 6C, along the line x=0. As seen, field strength amplification reaches a maximum of about 1,400 (amplification over incident light) at the point y=0.5, close to the upper particle in Fig. 6c.

A similar set of plots is shown in Figs 7a-7c, but where the lens here is constructed of four symmetrical particles, as seen from the field distribution diagram in Fig. 7c. Fig. 7b shows a symmetrical distribution of E along the line x equal zero as the y coordinate varies from the bottom to the top. When the plot is constructed along the diagonal line between -1, -1 and +1, +1, the plot seen in Fig. 8 is achieved, showing an amplification of nearly 3000 at points near between the particles away from the center.

According to prevailing mechanism, Raman enhancement is electromagnetic mechanism, where Raman signal is proportional to  $E^4$  (M.Moskovits, Rev. Mod. Phys. v. 57, p. 783, 1985 ) where E is local enhancement of field in the area of molecule. In the case of a field amplification factor 500, the Raman signal enhancement would be  $500^4 = 6.25 \times 10^{10}$ , which is significantly higher than has been reported in the literature. To obtain this enhancement, the sample molecule should be in center of a multi-particle nanolens. However, if the molecule is also close to a plasmon resonance surface, the field enhancement can be as high as 3,000, giving a Raman signal enhancement of up to  $8.1 \times 10^{15}$ , allowing single molecule chemical groups to be detected.

Although the invention has been described with respect to particular embodiments and applications, it will be understood that various changes and modification may be made without departing from the invention.

## IT IS CLAIMED:

1. Apparatus for examining the identity of chemical groups in a sample attached to a surface, comprising
  - 5 a substrate having a mirror surface on which the sample is supported, and which is formed of a plasmon resonant metal,
  - a source of a beam of light,
  - a lens assembly having a tip region and a nanolens composed of one or more plasmon resonance particles disposed on the tip region, and arranged
    - 10 thereon to produce, when the light beam is directed through the nanolens, near-field electromagnetic gap modes in a space between the nanolens and a confronting detection region on the substrate surface, in a gap between the nanolens and substrate that is 40 nm or less,
    - a focusing mechanism for moving the lens assembly toward and away
      - 15 from the substrate surface, with a gap of less than 40 nm, to produce electromagnetic gap modes that enhance the Raman spectroscopy signals produced by the sample in the detection region;
      - a detector for receiving light emitted by or scattered from the sample at the detection region, and for converting the received light into a gap-mode
        - 20 enhanced Raman spectrum, whereby the sample chemical group at the detection region can be identified, and
        - a translation mechanism for translating the lens assembly relative to said substrate, to position the lens assembly over different detection regions of the substrate.
- 25
2. The apparatus of claim 1, wherein the nanolens in said assembly includes at least said three plasmon resonance particles arranged symmetrically about a central axis that is normal to the plane of the substrate surface, each particle is less than 200 nm in its largest dimension, and the distance across any pair of
  - 30 particles is substantially less than the wavelength of the light beam.
3. The apparatus of claim 2, wherein said particles are spherical.

4. The apparatus of claim 2, wherein said particles are ellipsoidal and arranged with their major axes oriented to intersect said central axis.
5. The apparatus of claim 2, wherein said light source produces a beam of  
5 circularly polarized light whose plane of polarization is normal to said central axis.
6. The apparatus of claim 1, wherein said lens assembly includes a cantilever beam having a tip region at its free end.
- 10
7. The apparatus of claim 6, wherein said focusing mechanism includes a piezo-electric driver operatively coupled to said beam.
8. The apparatus of claim 7, wherein said focusing mechanism is operative to  
15 bring said nanolens to a selected distance between 0.1 and 5 nm of the substrate surface.
9. The apparatus of claim 1, wherein said translation mechanism includes a piezoelectronic drive.
- 20
10. The apparatus of claim 1, for use in sequencing a linear strand of nucleic acid, by examining the chemical-group bases of the nucleic acid strand, wherein the substrate includes molecular anchors for holding the nucleic acid strand in a stretched linear condition, and the translation mechanism is operable to move  
25 the lens assembly along the length of the strand, for examining and identifying each base of the strand sequentially.
11. The apparatus of claim 10 for examining a plurality of substantially linear samples simultaneous, which includes a plurality of linearly aligned cantilever  
30 lens assemblies, each of whose position toward and away from the substrate surface can be individually controlled by a corresponding focusing mechanism

associated with each lens assembly, and which are translated as a unit by a single translation mechanism.

12. The apparatus of claim 11, for use in sequencing a plurality of linear strands  
5 of nucleic acid, by examining the chemical-group bases of the nucleic acid strands, wherein the substrate includes molecular anchors for holding each of the nucleic acid strands in a stretched linear condition, and the translation mechanism is operable to move the lens assembly along the lengths of the strands, for examining and identifying each base of the strands sequentially.

10

13. A method for examining the identity of chemical groups in a sample, comprising

attaching the sample to a substrate having a mirror surface on which the sample is supported, and which is formed of a plasmon resonant metal,

15 directing a beam of light onto a nanolens in a lens assembly having a tip region and a nanolens disposed on the tip region and composed of one or more plasmon resonance particles which are arranged on the tip region to produce near-field electromagnetic gap modes in a space between the nanolens and a confronting detection region on the substrate surface, when the gap between the  
20 nanolens and substrate is 30 nm or less,

moving the lens assembly toward or away from the substrate surface, with a spacing between the nanolens and substrate surface of less than 30 nm, to produce electromagnetic gap modes that enhance the Raman spectroscopy signals produced by the sample in the detection region;

25 receiving light emitted by or scattered from the sample at the detection region, and

converting the received light into a gap-mode enhanced Raman spectrum, whereby the sample chemical group at the detection region can be identified.

30 14. The method of claim 13, wherein said moving is carried out to bring said nanolens to a selected gap distance between 0.1 and 5 nm of the substrate surface.

15. The method of claim 13, wherein said directing includes directing the light beam onto a nanolens composed of at least said three plasmon resonance particles arranged symmetrically about a central axis that is normal to the plane of the substrate surface, each particle is less than 200 nm in its largest  
5 dimension, and the distance across any pair of particles is substantially less than the wavelength of the light beam.
16. The method of claim 15, wherein said directing includes directing onto said lens, a beam of circularly polarized light whose plane of polarization is normal to  
10 said central axis.
17. The method of claim 15, for use in sequencing a linear strand of nucleic acid, wherein said attaching includes stretching the strand linearly, and anchoring opposite end portions of the strands to said substrate, and which  
15 further includes translating the lens assembly with respect to the sample on the substrate, to position the nanolens adjacent successive chemical-group bases in the strand.
18. The method of claim 17, for use in sequencing a plurality of linear strands of  
20 nucleic acid samples, wherein said attaching includes anchoring the samples in a plurality of parallel strands, and said translating includes translating the lens assembly with respect to the samples on the substrate, to position the nanolens adjacent successive chemical-group bases in each of the strands.



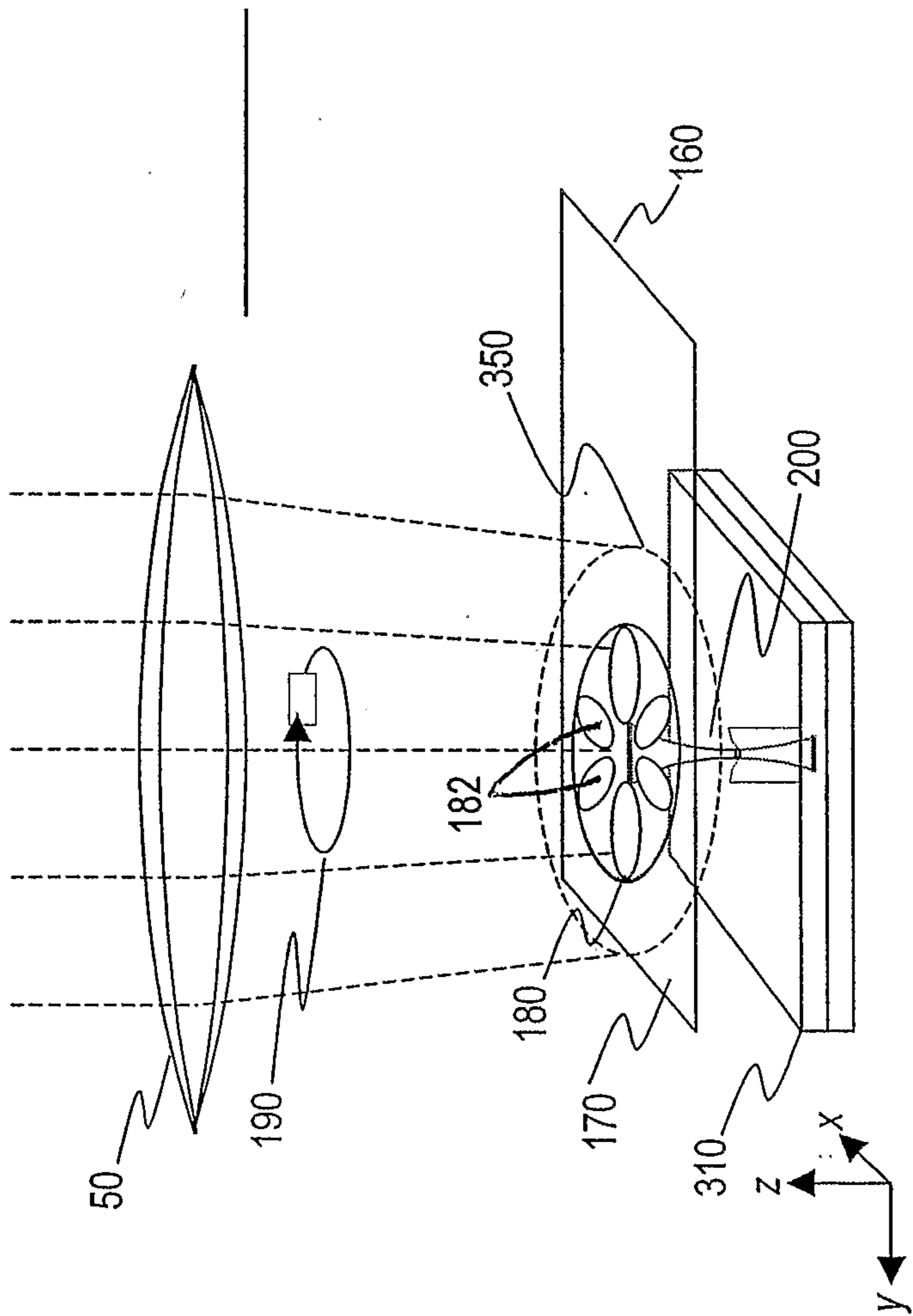

Fig. 2a

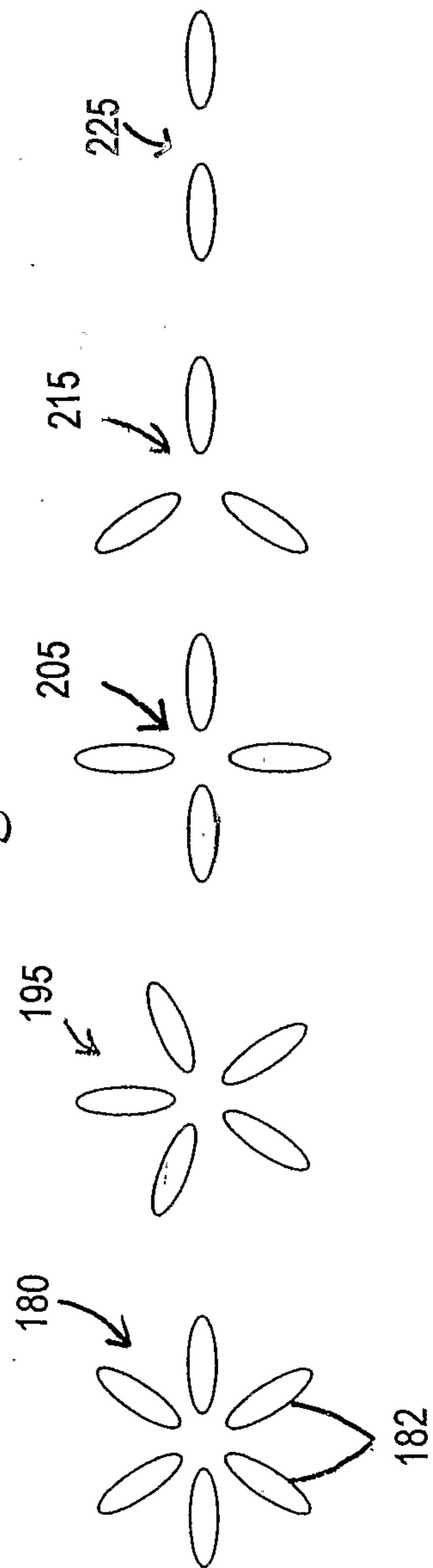

Fig. 2b

Fig. 3a

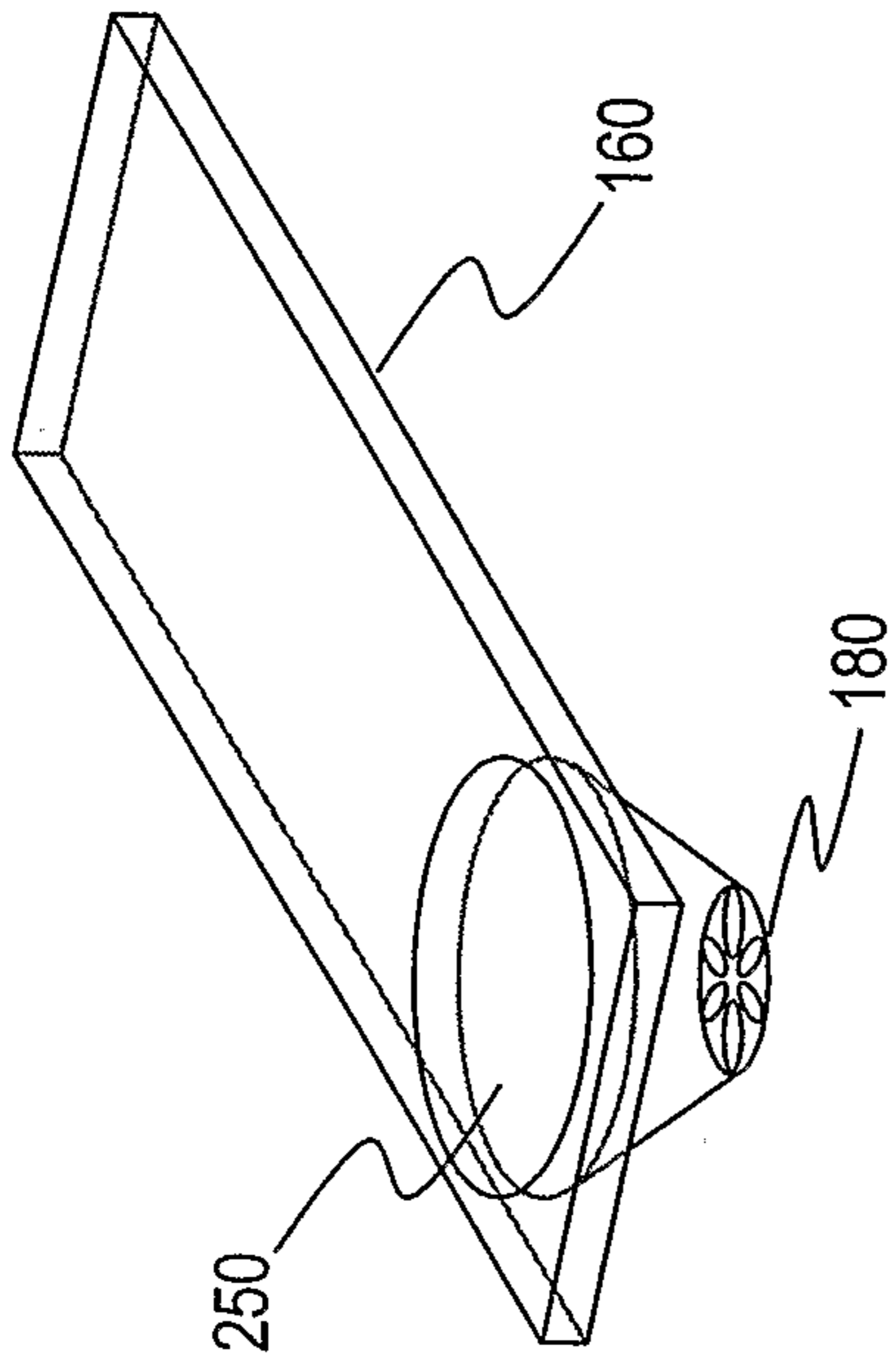
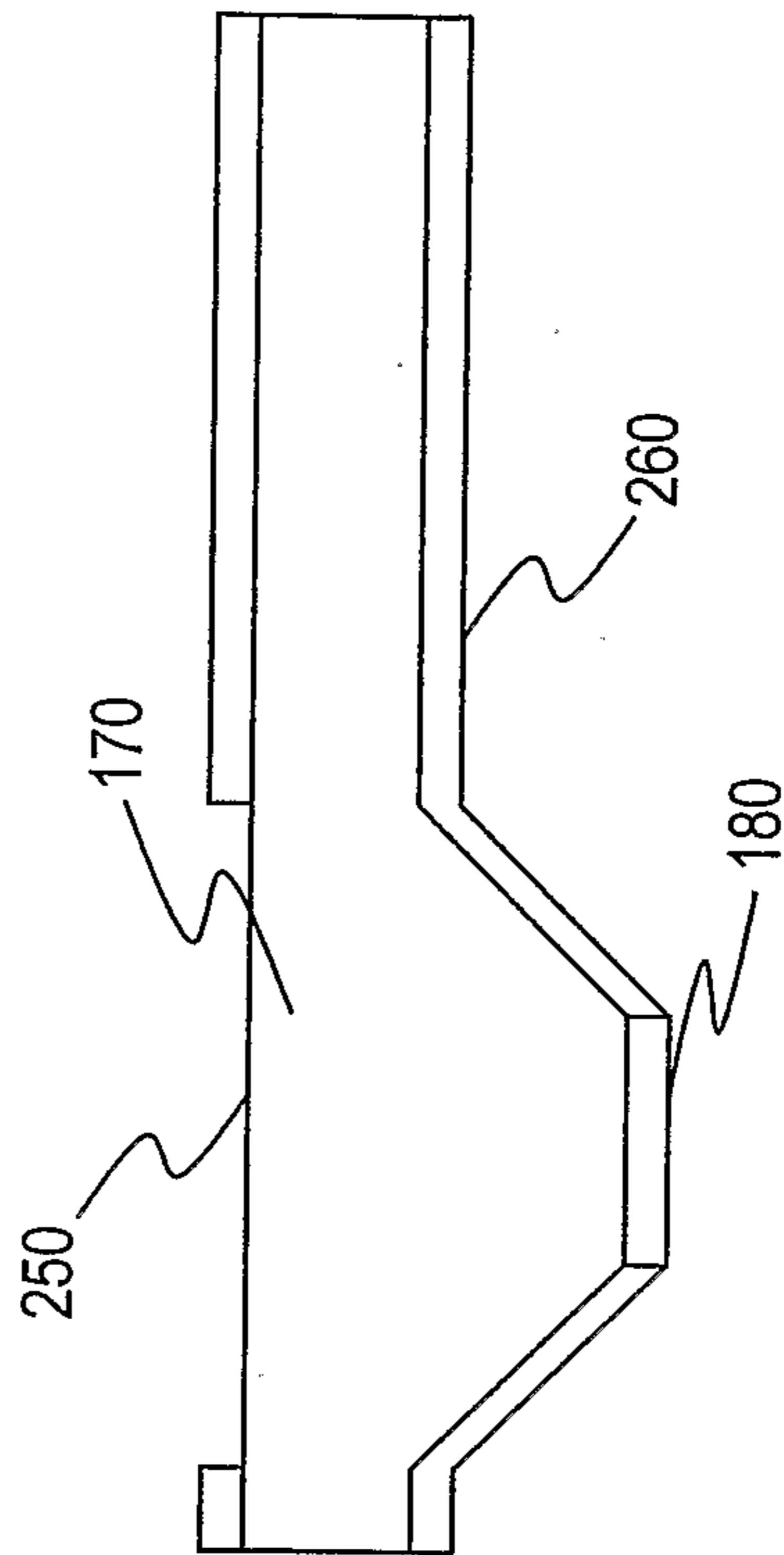

Fig. 3b



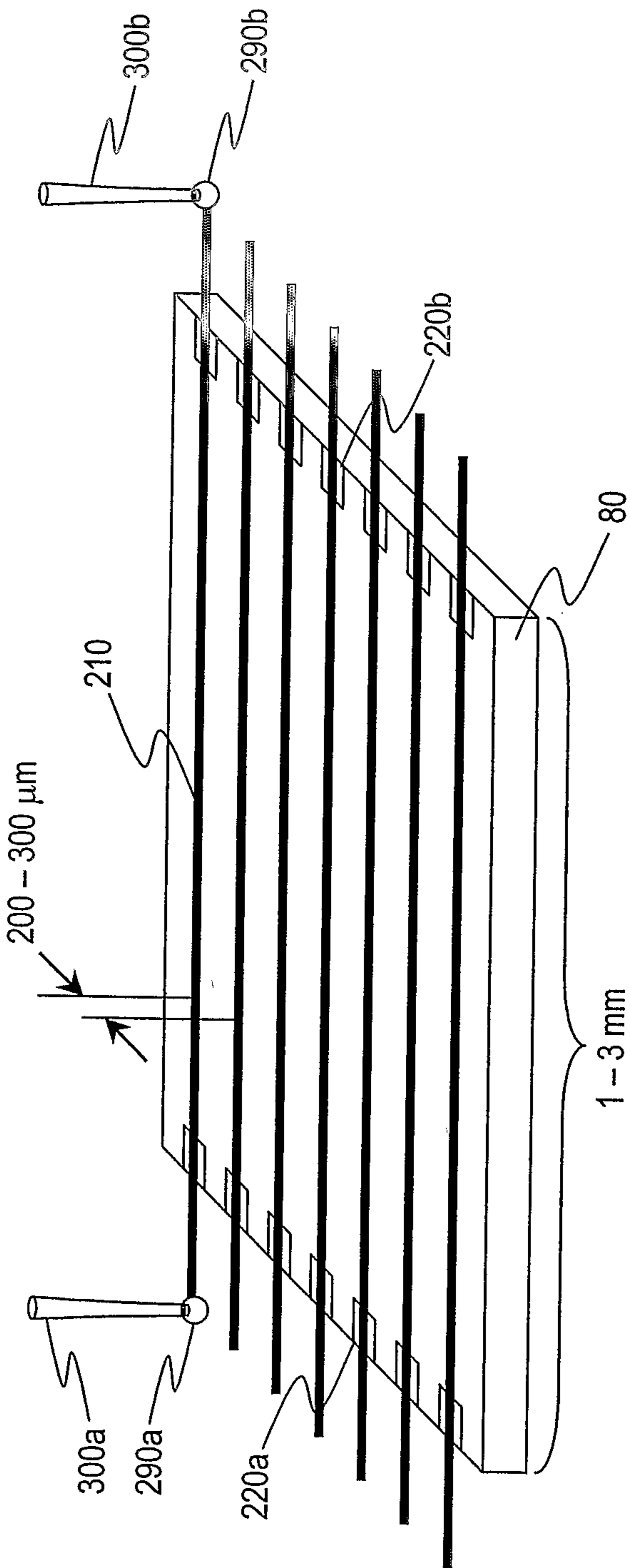

Fig. 4

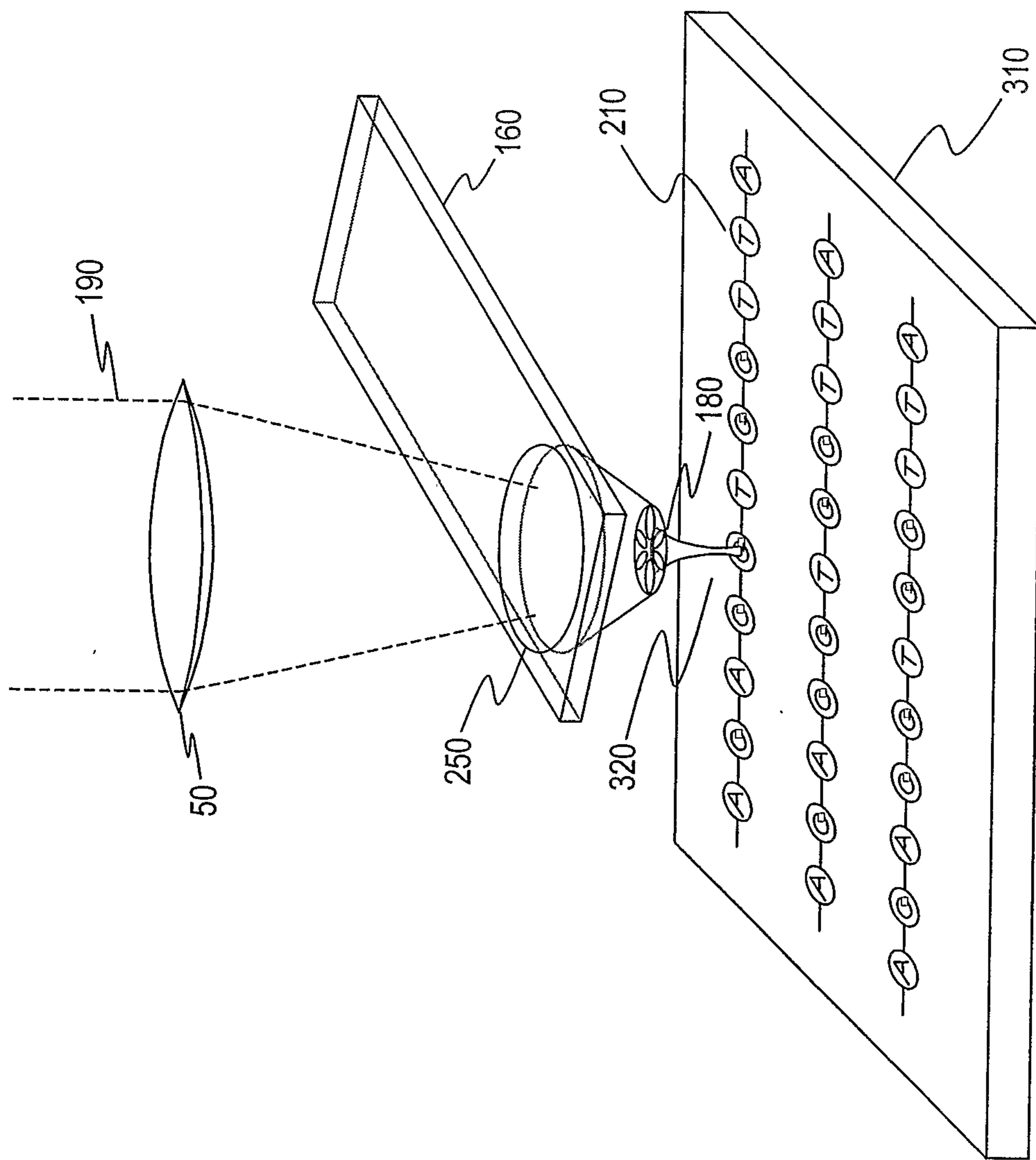

Fig. 5a

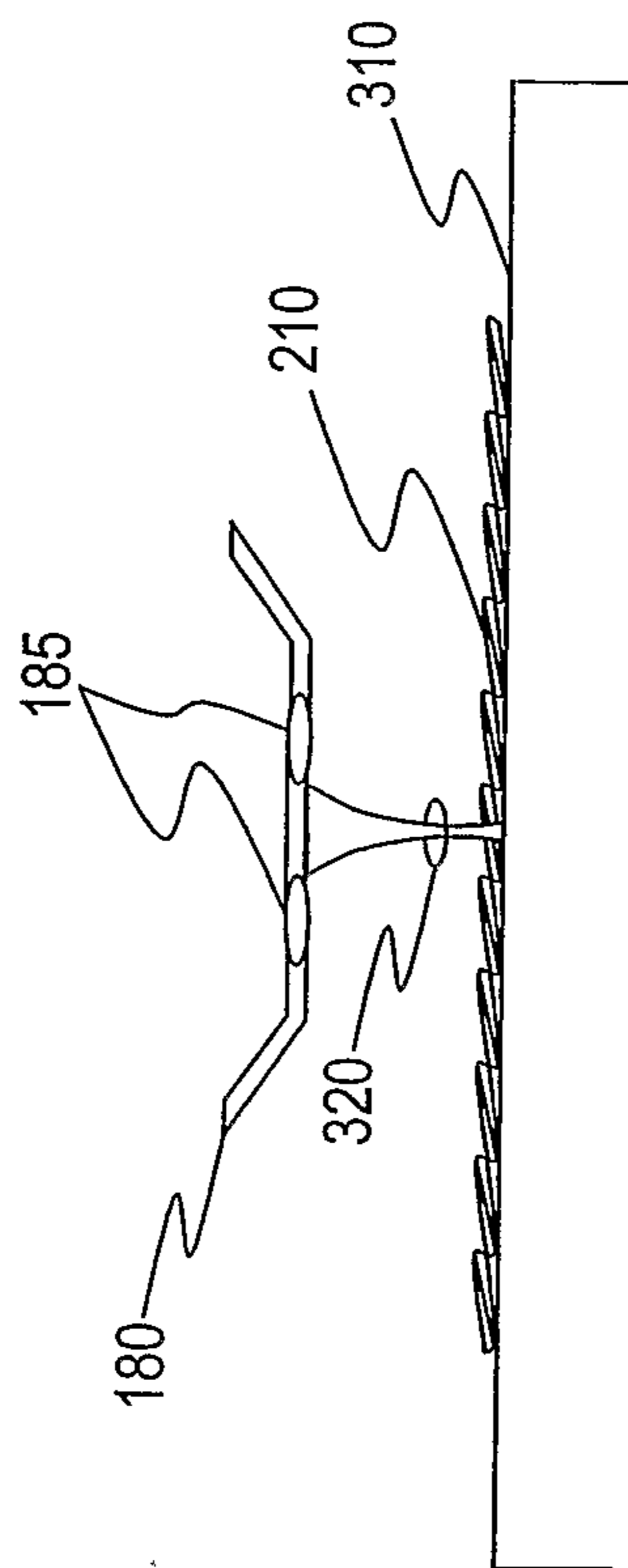

Fig. 5b

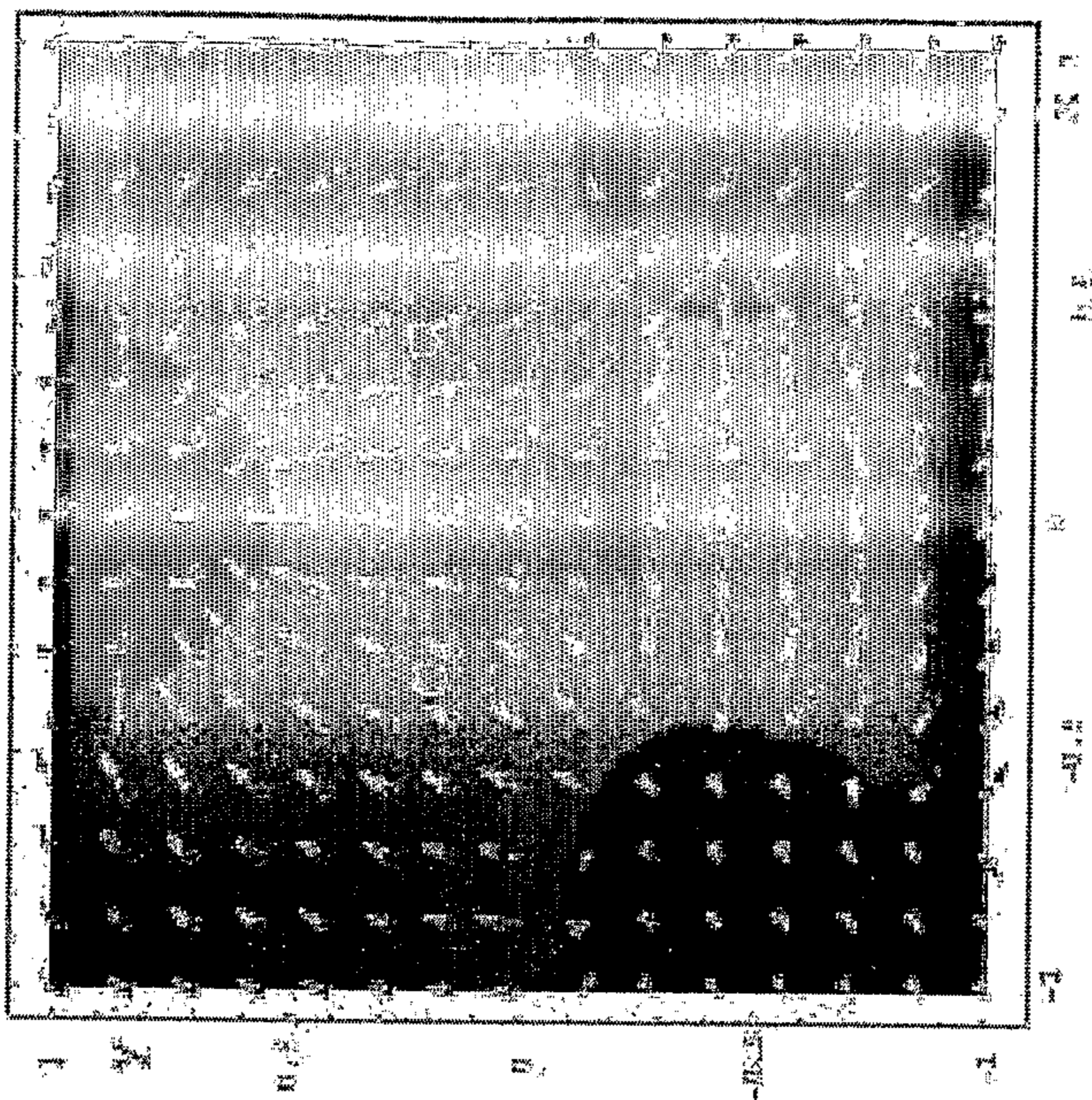
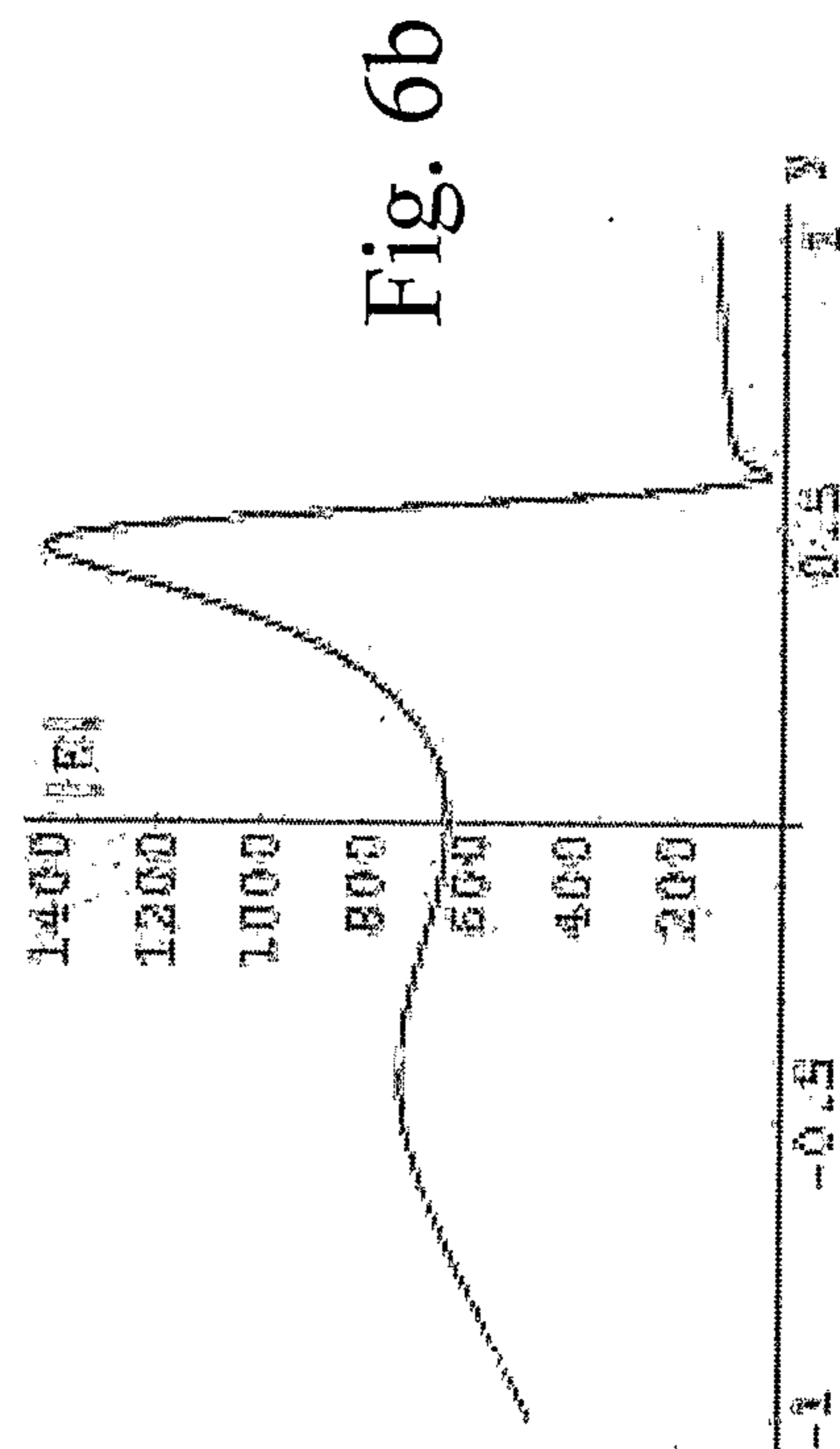
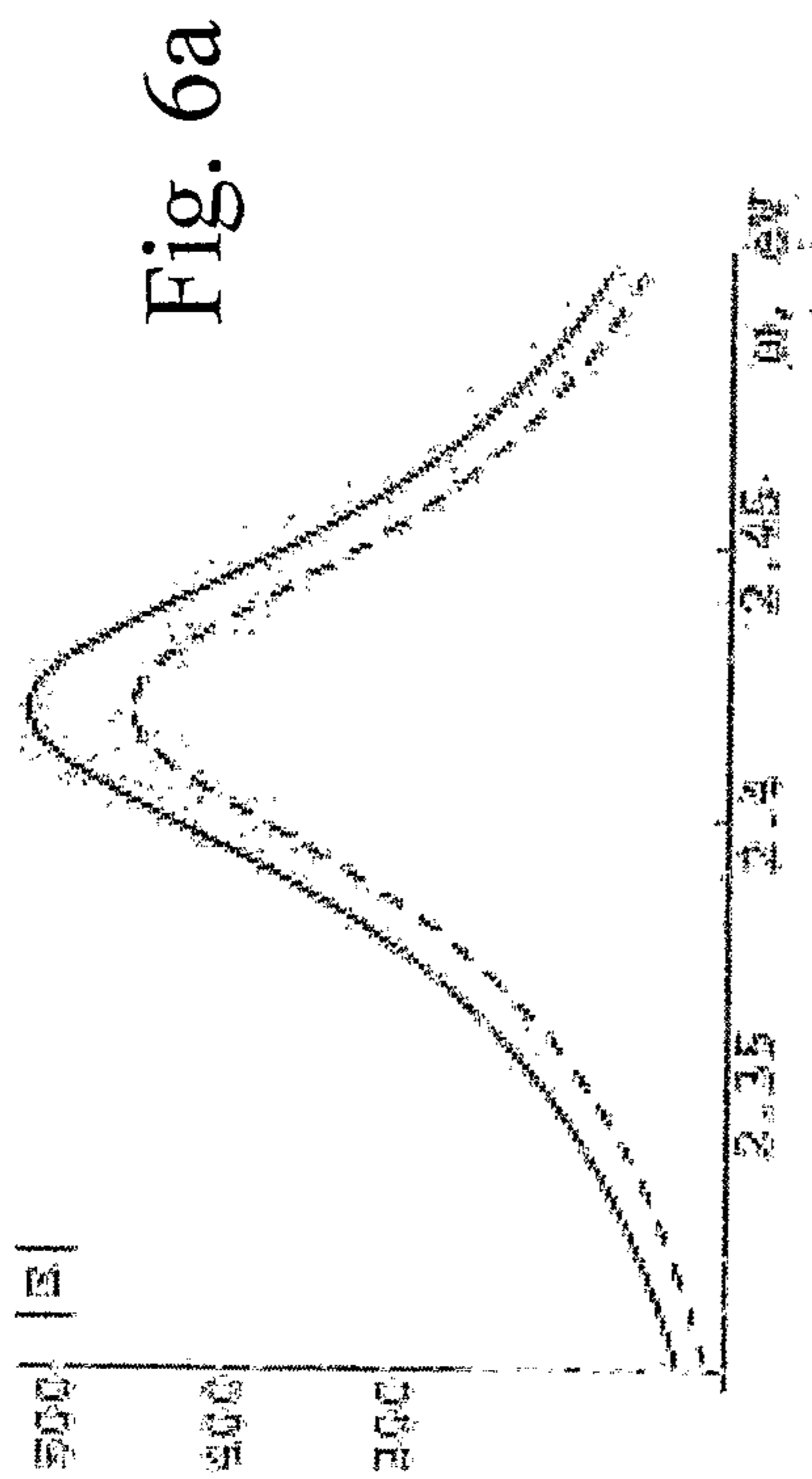

Fig. 6c

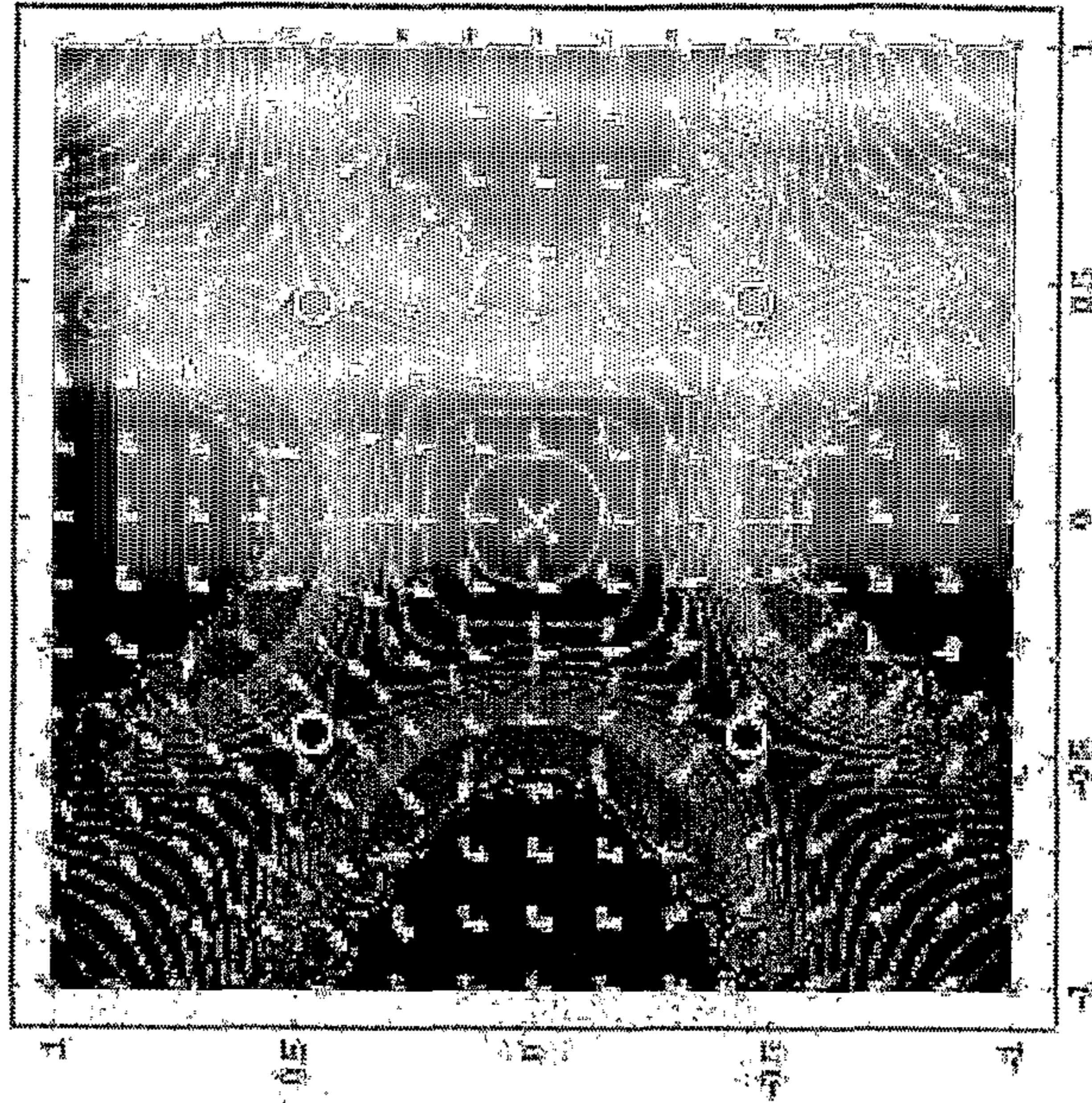
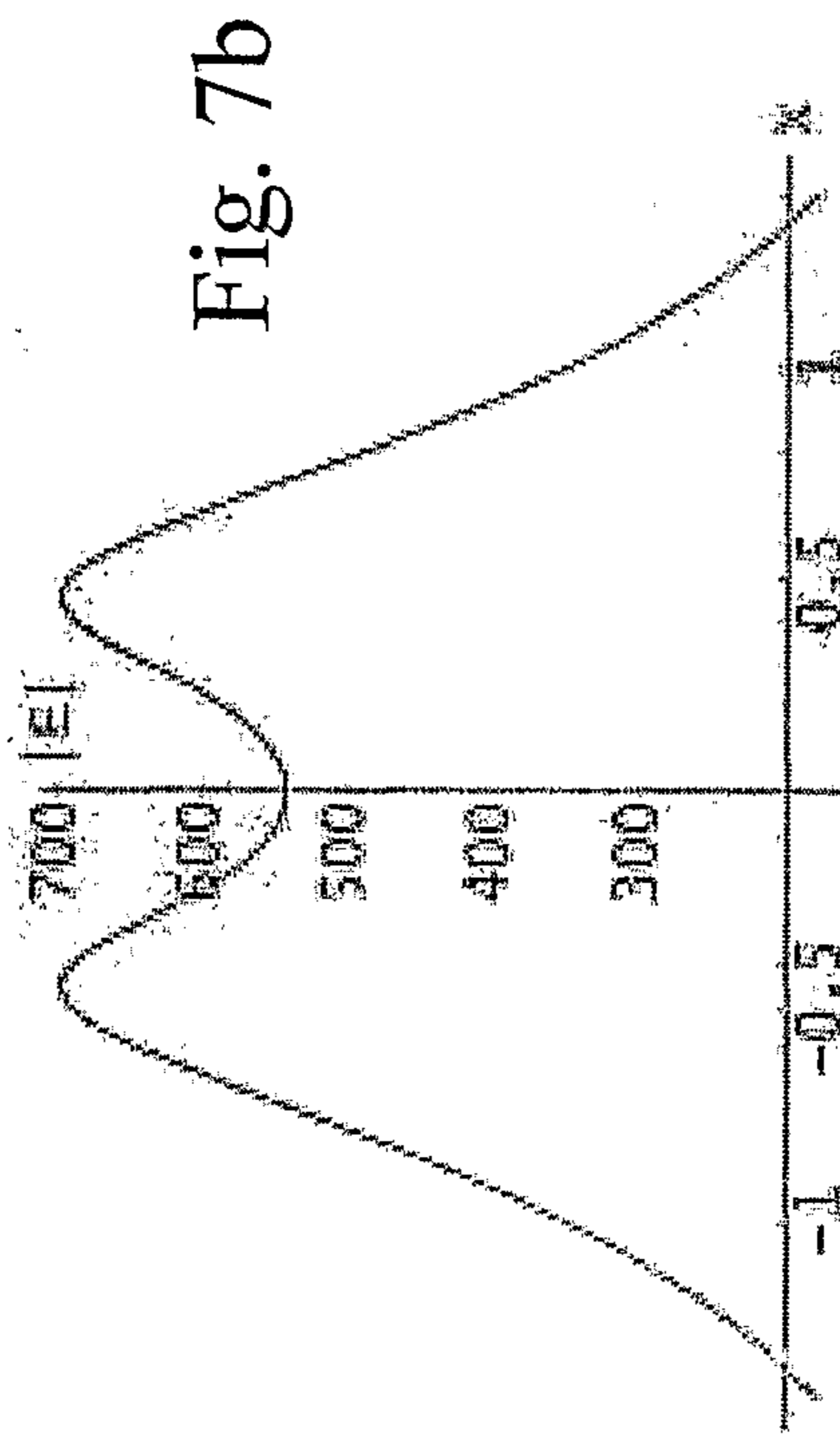
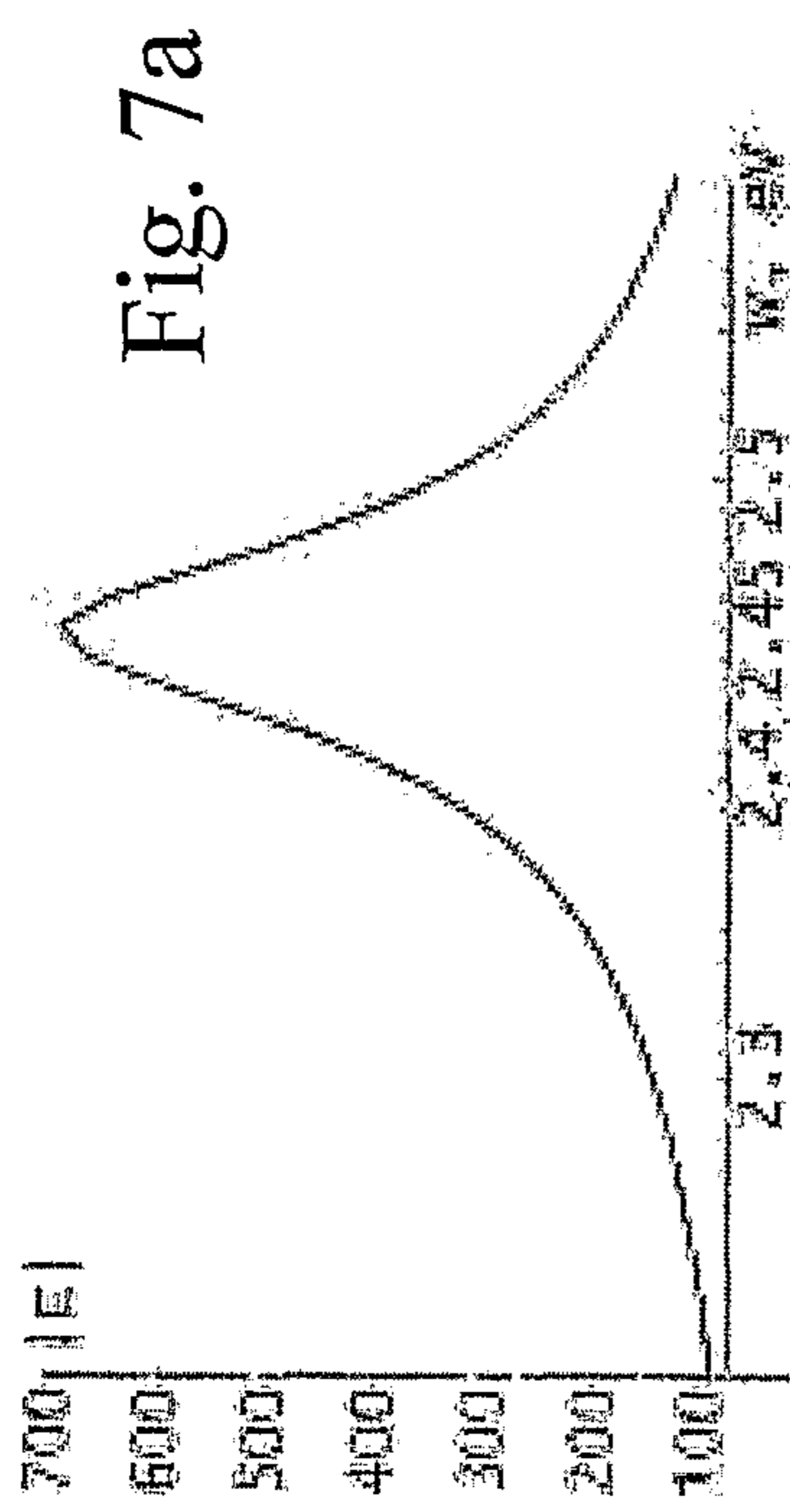

Fig. 7c

9/9

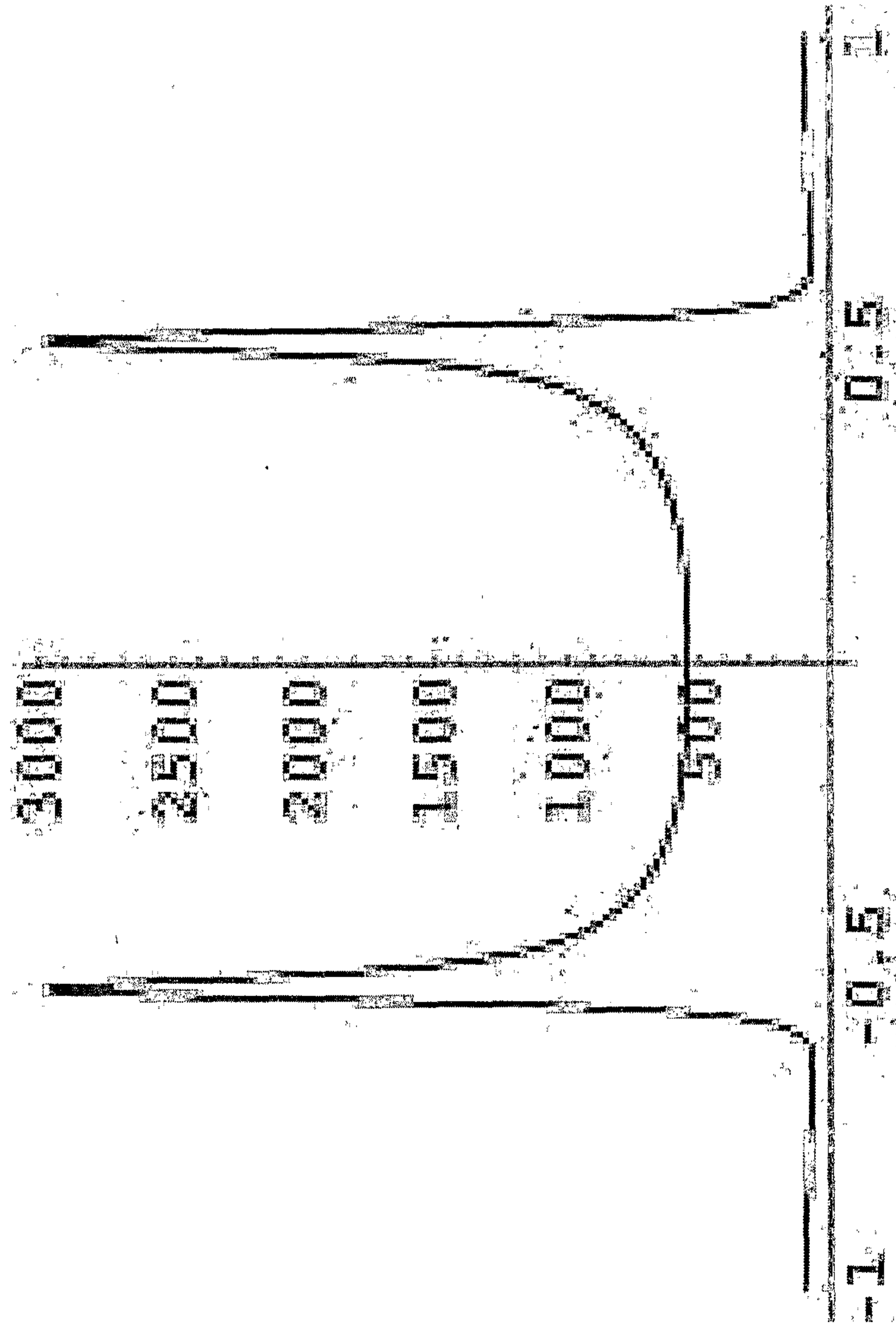

Fig. 8

