

T. BLOOMER.  
ANCHOR.

APPLICATION FILED JUNE 19, 1908.

915,545.

Patented Mar. 16, 1909.

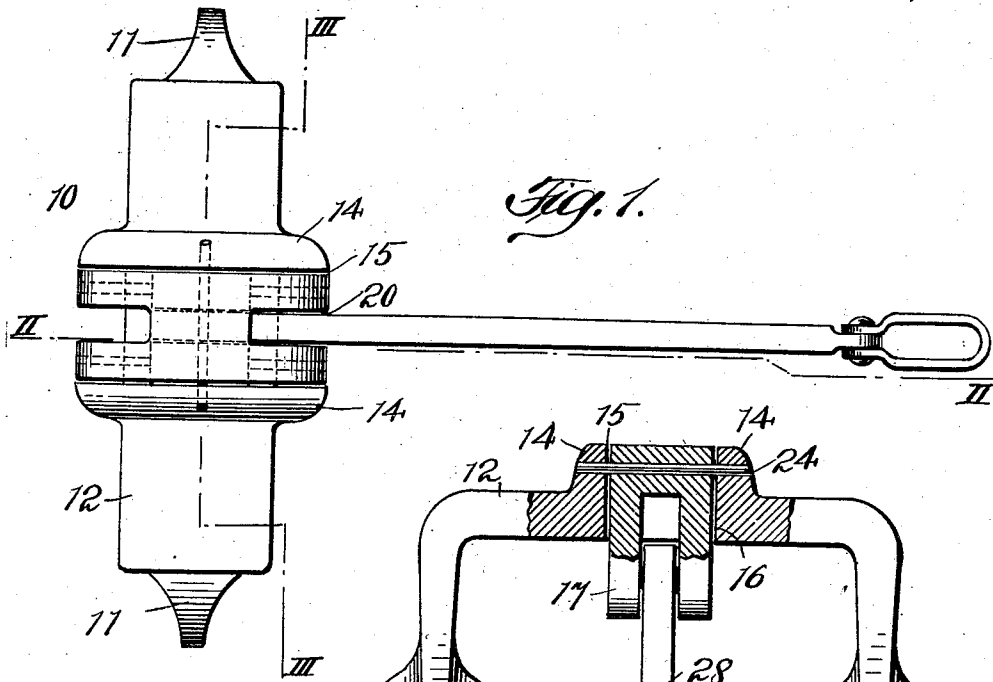

Fig. 1.

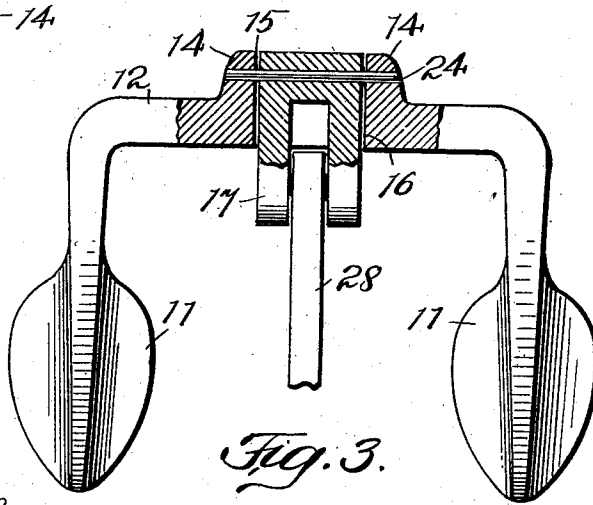

Fig. 3.

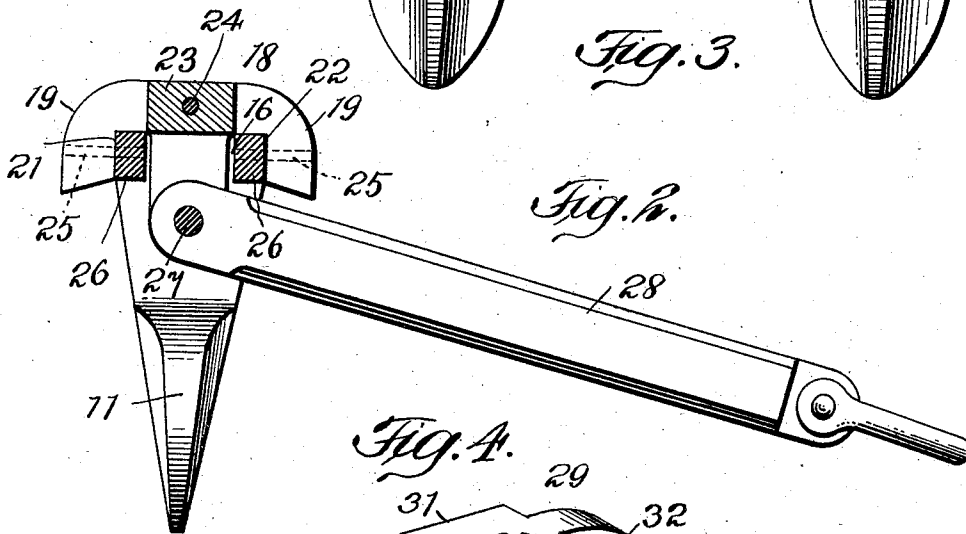
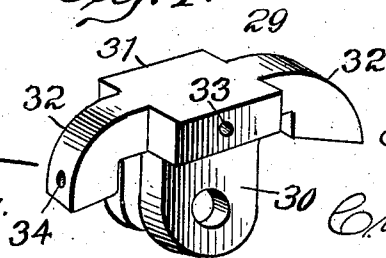

Fig. 2.

Fig. 4.



WITNESSES  
*Julius H. [Signature]*  
A. Richmond

INVENTOR  
Thomas Bloomer  
BY  
*Criswell & Criswell*  
ATTORNEYS

# UNITED STATES PATENT OFFICE.

THOMAS BLOOMER, OF TROY, NEW YORK.

## ANCHOR.

No. 915,545.

Specification of Letters Patent.

Patented March 16, 1909.

Application filed June 19, 1908. Serial No. 439,452.

*To all whom it may concern:*

Be it known that I, THOMAS BLOOMER, a subject of the King of England, and a resident of Troy, county of Rensselaer, State of New York, have invented certain new and useful Improvements in Anchors, of which the following is a full, clear, and exact description.

This invention relates more particularly to a stockless anchor which may be made entirely of wrought iron.

The primary object of the invention is to provide an anchor in which the shank may be positively held to the head and which has a fastening part therefor made to grip the head of the anchor in such a way that the anchor will be much stronger and better adapted for use than by the ordinary method of construction.

A further object of the invention is to provide a simple and effective fastening means for a part of the anchor, which may be readily made and which may be quickly applied to the head of the anchor.

With these and other objects in view, the invention will be hereinafter more particularly described with reference to the accompanying drawings, which form a part of this specification, and will then be pointed out in the claims at the end of the description.

In the drawings, Figure 1 is a plan view of one form of anchor embodying my invention. Fig. 2 is a longitudinal section taken on the line II—II of Fig. 1. Fig. 3 is a transverse section, partly in elevation, taken on the line III—III of Fig. 1; and Fig. 4 shows another form of gripping and fastening device.

The anchor 10 may have the parts or body thereof made of wrought iron formed from scraps so as to make the parts very strong and adapted for rough usage, or the said parts may be made of malleable iron or other material, and said body has the parts 11 for engaging purposes as is usual in anchors of this character. The body has a head 12 of any suitable form, and said head is provided with shoulders 14 forming a recess 15 between the same. This recess 15 extends across the head 12, and extending through the head is a rectangular or other opening 16, through which is adapted to pass the inward-projecting bifurcated part 17 of a clamping and gripping device 18. This device 18 has two jaws 19, which may be cut centrally thereof, as at 20, and said jaws

have angular gripping surfaces, as at 21, which are adapted to fit over the angular sides 22 of the head 12 between the shoulders 14, thus preventing the device from having a transverse or longitudinal movement with respect to the anchor head and firmly holding the said device to the head. The device 18 has a block portion 23 through which may pass a pin or rod 24, which may extend through the shoulders or flanges 14 to hold the said device in position, and through each part of the jaws and on each side of the slot 20 may be forced a pin or bolt 25, which is adapted to pass through the jaws and engage the bars or members 26 having the angular engaging part of the head 12, thus serving further to hold the device 18 to the head 12.

The device 18 may have the part 17 adapted to fit the opening 16 through the head and pivotally held to the lugs, at 27, is a shank 28, which may be so arranged as to have its forward movement relative to the position of the engaging parts 11 limited by the bars or parts 26 of the head 12.

Instead of the clamping and gripping device being made in the form shown in Figs. 1 to 3, the said device may be formed as shown in Fig. 4 or otherwise constructed. As shown in said figure, the device 29 is provided with the lugs or a bifurcated part 38 for engaging the shank 28 and which is adapted to fit between the shoulders 14 as already described. Projecting from the block portion 31 are the gripping jaws 32, one on each side of the block 31 and extending transversely of the head, and said jaws are centrally located so as to provide two gripping members instead of four as shown in the other figures. In this case the head may have the shoulders extend inwardly so that the jaws 32 will fit snugly between the same, in which case the recess 15 will correspond substantially to the shape of the block 31 and the gripping jaws or members 32. As in the other views the device 29 may have an opening 33 and a pin or bolt to fasten the same to the shoulders 14, and each jaw 32 may have an opening 34 for a pin or other fastening means to be passed therethrough and engage the anchor head.

From the foregoing it will be seen that simple and efficient means are provided whereby the shank of the anchor may be readily secured and properly held to the anchor head; that the fastening means pro-

vided for the shank will make the anchor very strong and adapted for rough usage; and that said device provides a positive clamping and gripping means whereby the shank may be properly held to the anchor head:

Having thus described my invention, I claim as new and desire to secure by Letters Patent:—

1. The combination with an anchor body having engaging parts and a head provided with an opening therethrough, of a clamping device having a block portion and gripping members adapted to engage the sides of the head and provided with a part projecting through the opening in the head, and a shank pivotally held to the projecting part of said device.

2. The combination with the head of an anchor, of a clamping device having gripping members adapted to engage the sides of the head and provided with a projecting part, and a shank pivotally held to the projecting part of said device.

3. In an anchor, the combination with a head provided with an opening therethrough and with shoulders extending transversely of the head on each side of the opening and forming a recess between said shoulders, of a clamping and gripping device adapted to fit said recess and provided with gripping jaws on opposite sides thereof having an angular gripping under part adapted to fit the head and provided with an inward-projecting bifurcated part extending through the opening of the head, bolts for fastening the device to said head, and a shank pivotally held to the bifurcated end of said device.

4. In an anchor, the combination with a head provided with an opening therethrough and with shoulders extending transversely of the head on each side of the opening forming a recess between said shoulders of a device adapted to fit said recess and provided

with gripping jaws on opposite sides thereof having an angular gripping under part adapted to fit an angular part of the head and provided with an inward-projecting part extending through the opening of the head, means for fastening the device to said head, and a shank pivotally held to the projecting part of said device.

5. In an anchor, the combination with a body having a head provided with angular engaging surfaces and with shoulders extending transversely of the head and forming a recess between said shoulders, of a device adapted to fit said recess and provided with gripping jaws on opposite sides thereof each having an angular gripping under part adapted to snugly fit the angular engaging surfaces of the head and provided with a projecting part, means for fastening the device to the head, and a shank pivotally held to the projecting part of said device.

6. In an anchor, the combination with a body having a head provided with an opening therethrough and with angular engaging surfaces and shoulders extending lengthwise of the anchor transversely of the head on each side of the opening forming a recess between said shoulders, of a device adapted to fit said recess and provided with inwardly-projecting gripping jaws on opposite sides thereof each having an angular gripping under part adapted to fit the angular engaging surfaces of the head and provided with an inward-projecting bifurcated part extending through the opening of the head, bolts for fastening the device to said head, and a shank pivotally held to the bifurcated part of said device.

This specification signed and witnessed this fifth day of June A. D. 1908.

THOMAS BLOOMER.

Witnesses:

CHARLES KERSHAW,  
GEORGE MILLER.