

(19) World Intellectual Property Organization
International Bureau



(43) International Publication Date
9 July 2009 (09.07.2009)

PCT

(10) International Publication Number
WO 2009/083401 A2

(51) International Patent Classification:
F25D 23/02 (2006.01)

(21) International Application Number:
PCT/EP2008/066967

(22) International Filing Date:
6 December 2008 (06.12.2008)

(25) Filing Language: English

(26) Publication Language: English

(30) Priority Data:
a2007/09230 31 December 2007 (31.12.2007) TR

(71) Applicant (for all designated States except US): **ARCELIK ANONIM SIRKETI** [TR/TR]; E5 Ankara Asfalti Uzeri, Tuzla, 34950 Istanbul (TR).

(72) Inventors; and

(75) Inventors/Applicants (for US only): **ERTURK, Derya**

[TR/TR]; E5 Ankara Asfalti Uzeri, Tuzla, 34950 Istanbul (TR). **TUKSAL, Mustafa** [TR/TR]; E5 Ankara Asfalti Uzeri, Tuzla, 34950 Istanbul (TR). **MUTLU, Sunay** [TR/TR]; E5 Ankara Asfalti Uzeri, Tuzla, 34950 Istanbul (TR). **AKYUZ, Ercan** [TR/TR]; E5 Ankara Asfalti Uzeri, Tuzla, 34950 Istanbul (TR).

(81) Designated States (unless otherwise indicated, for every kind of national protection available): AE, AG, AL, AM, AO, AT, AU, AZ, BA, BB, BG, BH, BR, BW, BY, BZ, CA, CH, CN, CO, CR, CU, CZ, DE, DK, DM, DO, DZ, EC, EE, EG, ES, FI, GB, GD, GE, GH, GM, GT, HN, HR, HU, ID, IL, IN, IS, JP, KE, KG, KM, KN, KP, KR, KZ, LA, LC, LK, LR, LS, LT, LU, LY, MA, MD, ME, MG, MK, MN, MW, MX, MY, MZ, NA, NG, NI, NO, NZ, OM, PG, PH, PL, PT, RO, RS, RU, SC, SD, SE, SG, SK, SL, SM, ST, SV, SY, TJ, TM, TN, TR, TT, TZ, UA, UG, US, UZ, VC, VN, ZA, ZM, ZW.

(84) Designated States (unless otherwise indicated, for every kind of regional protection available): ARIPO (BW, GH, GM, KE, LS, MW, MZ, NA, SD, SL, SZ, TZ, UG, ZM,

[Continued on next page]

(54) Title: A COOLING DEVICE

Figure 1

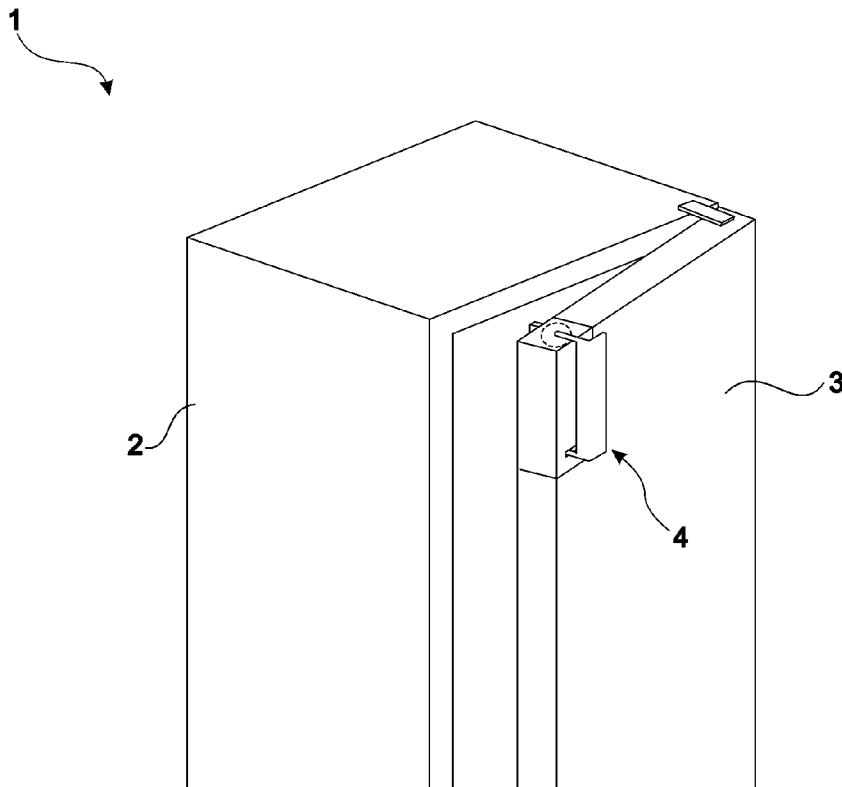

(57) Abstract: The present invention relates to a cooling device (1) which comprises a door-opening mechanism (4) that enables the user to open the door (3) using lesser force by means of the back and forth motion of the pusher (10).

WO 2009/083401 A2



ZW), Eurasian (AM, AZ, BY, KG, KZ, MD, RU, TJ, TM),
European (AT, BE, BG, CH, CY, CZ, DE, DK, EE, ES, FI,
FR, GB, GR, HR, HU, IE, IS, IT, LT, LU, LV, MC, MT, NL,
NO, PL, PT, RO, SE, SI, SK, TR), OAPI (BF, BJ, CF, CG,
CI, CM, GA, GN, GQ, GW, ML, MR, NE, SN, TD, TG).

Published:

— *without international search report and to be republished
upon receipt of that report*

Description**A COOLING DEVICE**

- [0001] The present invention relates to a cooling device comprising a door opening mechanism that enables the door to be opened easily.
- [0002] In the interior of cooling devices like the refrigerator, freezer, a vacuum is created due to the circulation of air during the cooling cycle. When the door is desired to be opened, sometimes the user may face difficulty in opening the door due to the created vacuum and the magnetic effect of the door gasket. In the state of the art, door grips that transfer the first motion to separate the door from the body by overcoming the mentioned vacuum and the magnetic forces, operating on the principle of levers are used. These door grips are moved by pushing forwards or pulling backwards by means of rotating about an axis. The part that the user pushes or pulls called the handle forms the long arm of the lever; the part that pushes the body, making the door ajar forms the short arm of the lever. The pusher element that forms the short arm pushes the body, providing the door to make its first movement to open by means of the force applied to the handle by the user. Then the user opens the door by pulling. Studies are under way to ameliorate door-opening mechanisms in the state of the art, by cutting cost prices through reducing the number of components and by enabling the user to open the door with the application of a minimum amount of energy.
- [0003] In the state of the art Patent Document No EP0891542, a freezer wherein a longer opening-closing arm that is used for the holding grip to open the door and the other shorter holding grip when activated, the opening-closing arm movably attached to and pressing on the body and the opening-closing arm are assembled together with its body to the door is explained.
- [0004] In the state of the art Patent Application No WO2004104332, the door grip element, which moves by pulling the grip and pushes the body to open the door, comprises locking means providing locking in various positions and one magnetic element.
- [0005] The aim of the present invention is the realization of a cooling device the

door of which is difficult to open because of the vacuum created during cooling cycle due to the pressure difference between the interior and the exterior environments enabled to be opened easily by applying a slight force.

[0006] A cooling device realized in order to attain the aim of the present invention is explicated in the attached claims. The door-opening mechanism used in the cooling device of the present invention, comprises a rotating disk that rotates along with the movement of the handle when the user pulls the handle to open the door. The pin element, which is vertical to the body with respect to the movement of the pin on the rotating disk, is transmitted to the pusher operatively connected to the pin. By this means, the pin moves back and forth and exerts pressure onto the body, enabling the door to be opened.

[0007] In one embodiment of the invention, the pin is seated inside a groove provided over the pusher to maintain a continuous connection between the pin and the pusher. Since only the elements of the rotation movement of the pin, which are almost vertical to the interior surface of the door, are aimed to be transmitted to the pusher, the groove is linear and extends almost parallel to the interior surface of the door.

[0008] In this embodiment, the pusher is "T" shaped. The groove is arranged on the upper side of the "T", whereas the lower end gets out of the bearing over the door and extends towards the body, exerting pressure thereon.

[0009] In one embodiment of the invention, the pusher and the pin are connected to one another by means of magnets arranged on the surfaces of the pusher and the pin.

[0010] The present invention enables the door to be opened easily, which otherwise would require great effort because of the impact of the vacuum created due to pressure difference, and provides the user effortless access into the body.

[0011] The cooling device realized in order to attain the aim of the present invention is illustrated in the attached figures, where:

[0012] Figure 1 – shows a perspective view of a cooling device,

[0013] Figure 2 – shows a schematic view of the door-opening mechanism in one

embodiment of the invention with the door at closed position,

[0014] Figure 3 – shows a schematic view of the door-opening mechanism in one embodiment of the invention with the door at open position,

[0015] Figure 4 – shows a schematic view of the door-opening mechanism in another embodiment of the invention with the door at closed position,

[0016] Figure 5 – shows a schematic view of the door-opening mechanism in another embodiment of the invention with the door at open position,

[0017] Figure 6 – shows a schematic view of the door-opening mechanism in one other embodiment of the invention with the door at closed position,

[0018] Figure 7 – shows a schematic view of the door-opening mechanism in one other embodiment of the invention with the door at open position.

[0019] The elements illustrated in the figures are numbered as follows:

1. Cooling device
2. Body
3. Door
4. Door-opening mechanism
5. Handle
6. Grip
7. Spring
8. Rotating disk
9. Pin
10. Pusher
11. Groove
12. Magnet

[0020] The cooling device (1) of the present invention comprises a body (2), a door (3), arranged on the body (2) providing access inside the body (2) and a door-opening mechanism (4) that enables the opening of the door (3) (Figure 1).

[0021] The door-opening mechanism (4) comprises a handle (5) attached to the door (3), a grip (6), one end of which is connected to the handle (5), and the other end fixed onto the door (3) in a way so as to be able to rotate, a spring (7) that exerts pressure onto the grip (6) enabling the return of the handle (5) back to initial position, a rotating disk (8) onto which the grip (6)

is mounted and which turns around the same point as the grip (6), a pin (9) arranged on either the upper or the lower surface of the rotating disk (8), and a pusher (10) which is operatively connected to the pin (9) and which transmits the movement of the handle (5) to the body (2), enabling the opening of the door (3).

- [0022] The pin (9) is provided on a point near the edge of the rotating disk (8). By this means the distance that the pin (9) covers together with the rotating disk (8) is increased.
- [0023] The pusher (10) moves back and forth inside a bearing provided on the door (3).
- [0024] When the user moves the grip (6) by pulling/pushing the handle (5), the rotating disk (8) and the pin (9) connected to the grip (6) also turn together with the grip (6). The pusher (10) shifted towards the body (2) with the movement of the pin (9), enables separating of the door (3) by abutting on the body (2). When the handle (5) is released, the grip (6) returns to its initial position under the pressure of the spring (7), together with the rotating disk (8), the pin (9), and the pusher (10).
- [0025] In one embodiment of the invention, the door-opening mechanism (4) comprises a groove (11) arranged on the pusher (10), inside of which the pin (9) is seated. The groove (11) and the pin (9) enable the pusher (10) and the rotating disk (8) to be connected to each other. The groove (11) is linear and extends parallel to the interior surface of the door (3). The groove (11) can be arranged horizontally or vertically, depending on the position of the rotating disk (8). By means of the groove (11), only the pin element, which is vertical to the body (2) with respect to the movement of the pin (9) on the rotating disk (8), is transmitted to the pusher (10). Therefore, the pusher (10) makes only back and forth movements, without any rotation movement. Consequently, friction forces created in case of rotation movements of the pusher while exerting pressure onto the body are avoided and the opening of the door (3) is facilitated. (Figure 2, Figure 3, Figure 6, and Figure 7)
- [0026] In this embodiment, the pusher (10) is "T" shaped. The groove (11) is arranged on the upper part of the "T". The lower part of the "T" exerts

pressure onto the body (2). The groove (11) inside which the pin (9) moves is perpendicular to the extremity of the "T" shaped pusher (10) that moves towards the body (2). Hence, only the vertical motion of the pin (9) is transmitted to the pusher (10), enabling the back and forth movements of the pusher (10). The amount of the motion that the pusher (10) makes towards the body (2) is directly proportional to the distance run by the pin (9) inside the groove (11) (Figure 2, Figure 3, Figure 6, and Figure 7).

[0027] In another embodiment of the invention, the door-opening mechanism (4) comprises two magnets (12), one on the pusher (10) and the other on the pin (9), arranged with the opposite poles facing one another. The pusher (10) is disposed near the rotating disk (8) in a manner so as to contact the pin (9). When the spring (7) pulls back the grip (6) and/or the rotating disk (8), the magnet (12) placed on the pin (9) attracts the magnet (12) placed on the pusher (10), enabling thus the pusher (10) to get back to initial position at the same time (Figure 4 and Figure 5).

[0028] In one other embodiment of the invention, the door-opening mechanism (4) is not activated by the user through the use of a handle (5) but by a motor (not shown on the figures) that turns the rotating disk (8) and a button (not shown on the figures) that starts running the motor. In this embodiment, the door-opening mechanism (4) is mounted onto the body (2) together with the motor (Figure 6 and Figure 7).

[0029] Due to the back and forth motion of the pusher (10), the door-opening mechanism (4) used in the cooling device (1) of the present invention enables the user to open the door (3) with less force.

Claims

1. A cooling device (1), which **comprises** a body (2), a door (3) arranged on the body (2) providing access inside the body (2), and a door-opening mechanism (4) comprising a handle (5) attached to said door (3), a grip (6), one end of which is connected to the handle (5) and the other fixed onto the door (3) in a way so as to be able to rotate, and a spring (7) that exerts pressure onto the grip (6), enabling the return of the handle (5) back to initial position, and **characterized by** a door-opening mechanism (4) comprising:
 - a rotating disk (8) onto which a grip (6) is mounted and which turns around the same point as the said grip (6),
 - a pin (9) arranged on either the upper or the lower surface of the rotating disk (8), and
 - a pusher (10) which is operatively connected to the pin (9), enabling the opening of the door (3) by transmitting the movement of the handle (5) to the body (2).
2. A cooling device (1) as described in Claim 1, **characterized by** the door-opening mechanism (4) comprising a groove (11) arranged on the pusher (10) inside of which the pin (9) is seated.
3. A cooling device (1) as described in Claim 2, **characterized by** the linear groove (11).
4. A cooling device (1) as described in Claim 3, **characterized by** the groove (11) that extends parallel to the interior surface of the door (8).
5. A cooling device (1) as described in any one of the Claims 2 to 4, **characterized by** the groove (11) which enables to transmit only the almost vertical component of the rotational motion of the pin (9) with respect to the body (2) to the pusher (10).
6. A cooling device (1) as described in any one of the Claims 2 to 5, **characterized by** the "T" shaped pusher (10), on the upper part of which the groove is arranged (11) and the lower part of which exerts pressure onto the body (2).
7. A cooling device (1) as described in Claim 1, **characterized by** the door-opening mechanism (4) comprising two magnets, one on the pusher (10) and the other on the pin (9), arranged with the opposite poles facing one

another.

8. A cooling device (1) as described in Claim 7, **characterized by** the pusher (10) which is disposed near the rotating disk (8) in a manner so as to contact the pin (9).

Figure 1

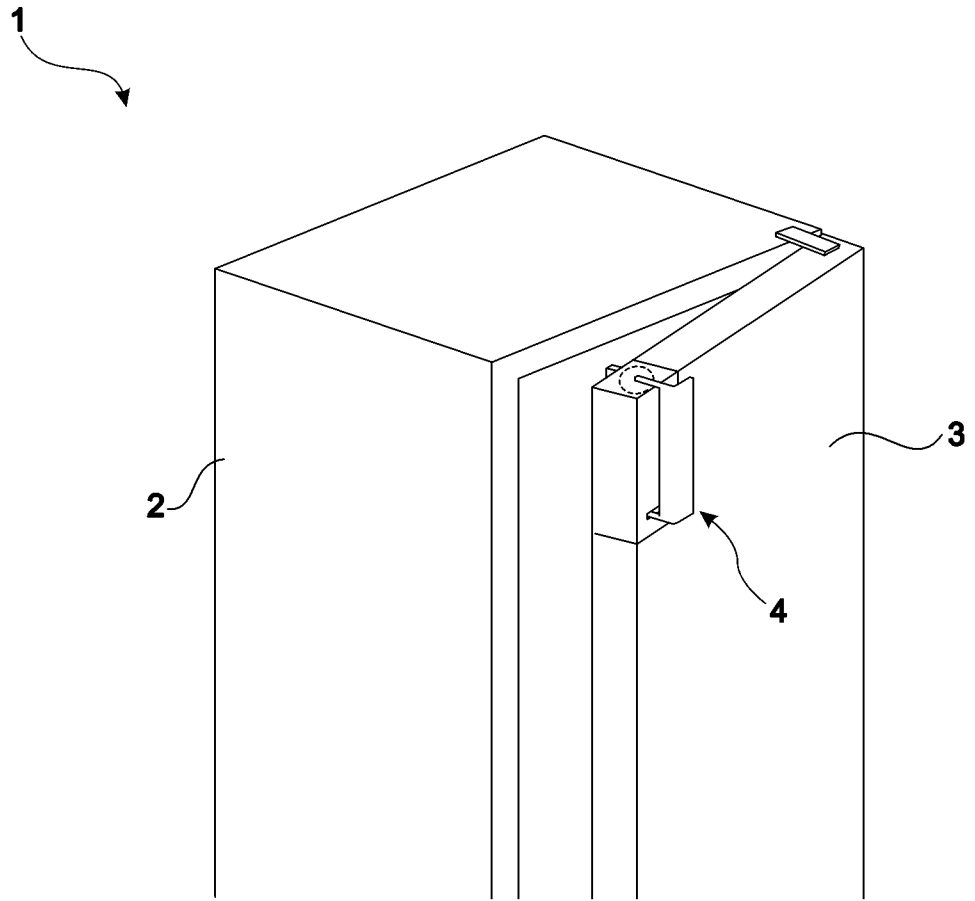

Figure 2

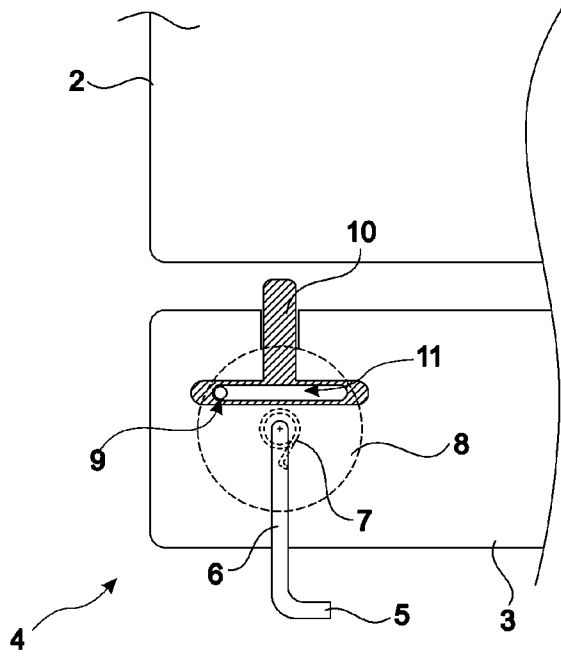

Figure 3

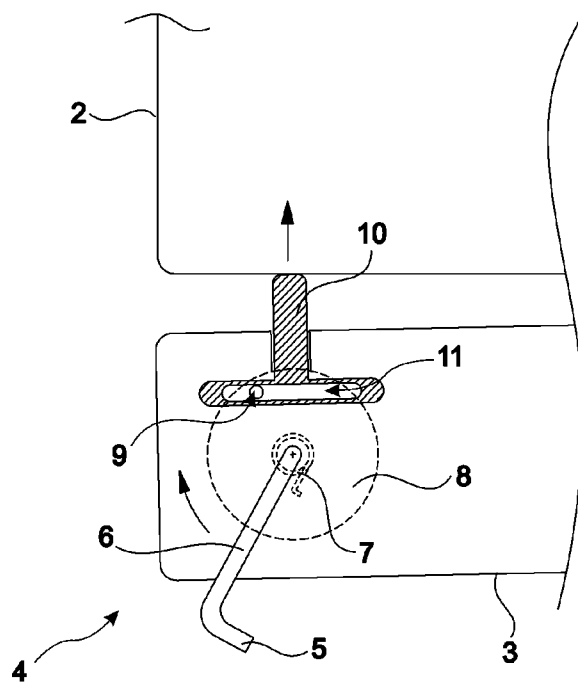

Figure 4

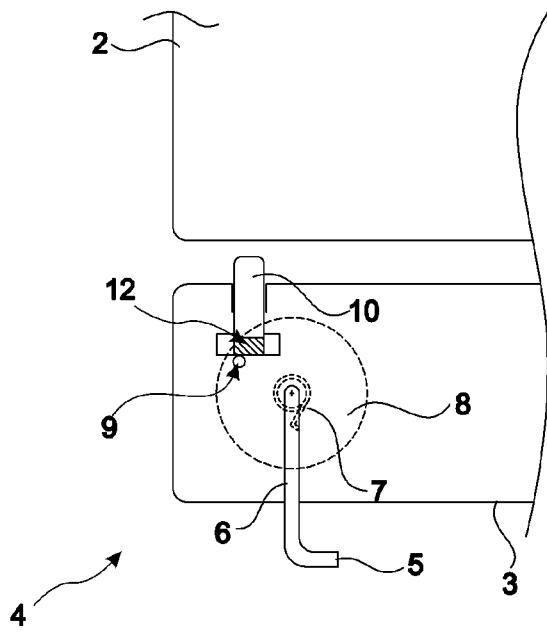

Figure 5

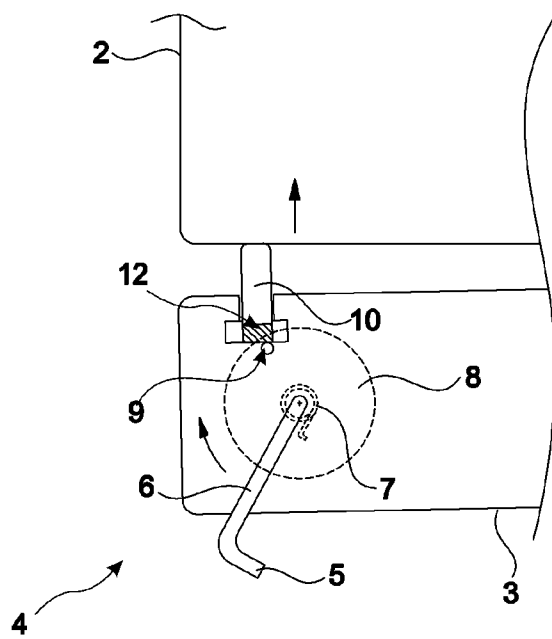

Figure 6

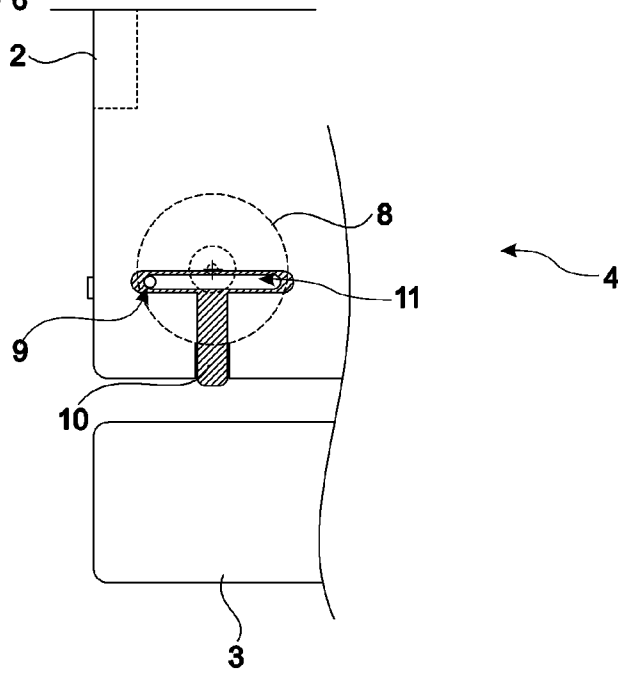

Figure 7

