

(No Model.)

2 Sheets—Sheet 1.

I. MANNING.
SEWING MACHINE.

No. 251,263.

Patented Dec. 20, 1881.

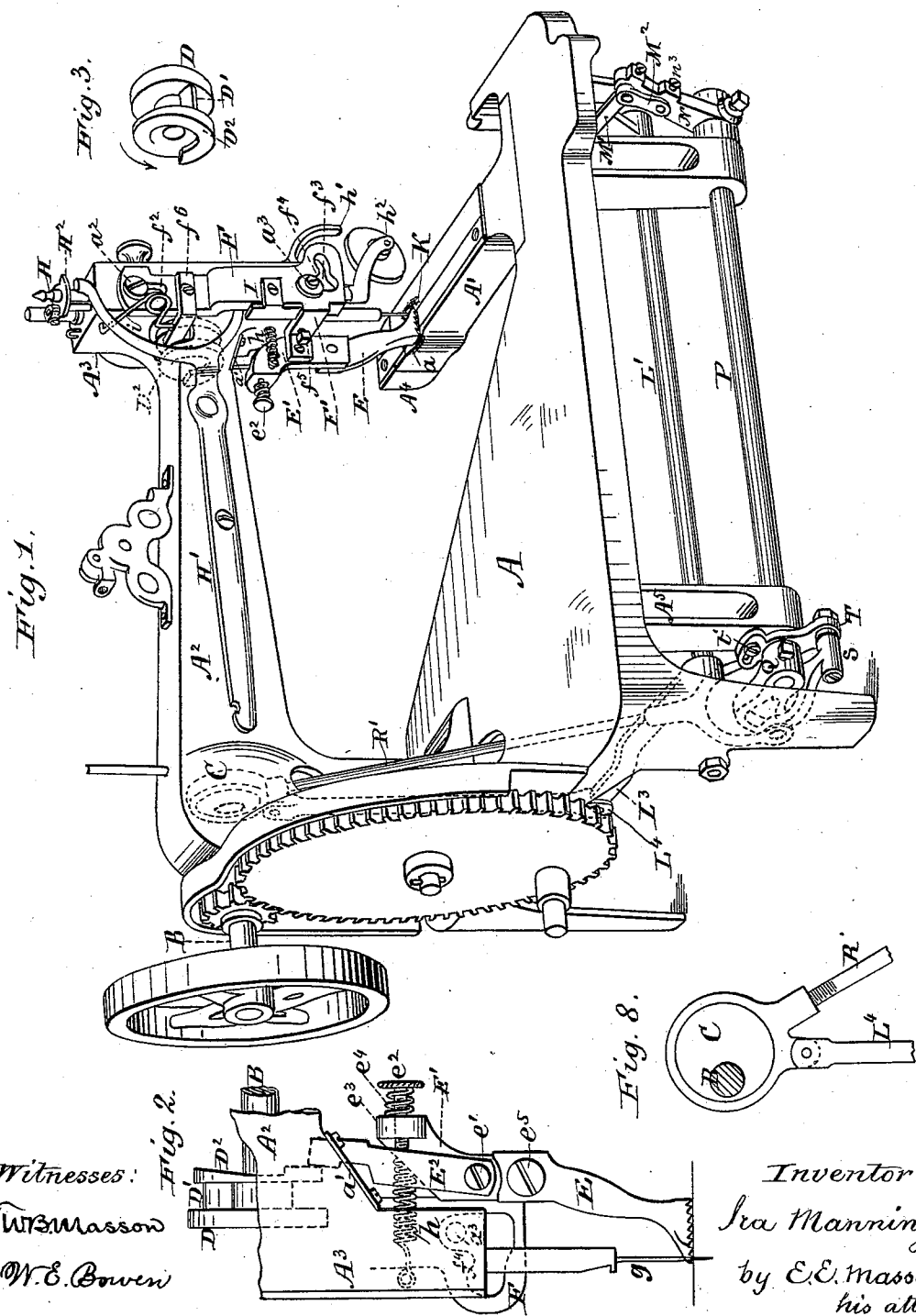

Witnesses:
W. E. Masson
W. C. Bowen

Inventor
Ira Manning
by E. E. Masson
his atty.

(No Model.)

2 Sheets—Sheet 2.

I. MANNING.
SEWING MACHINE.

No. 251,263.

Patented Dec. 20, 1881.

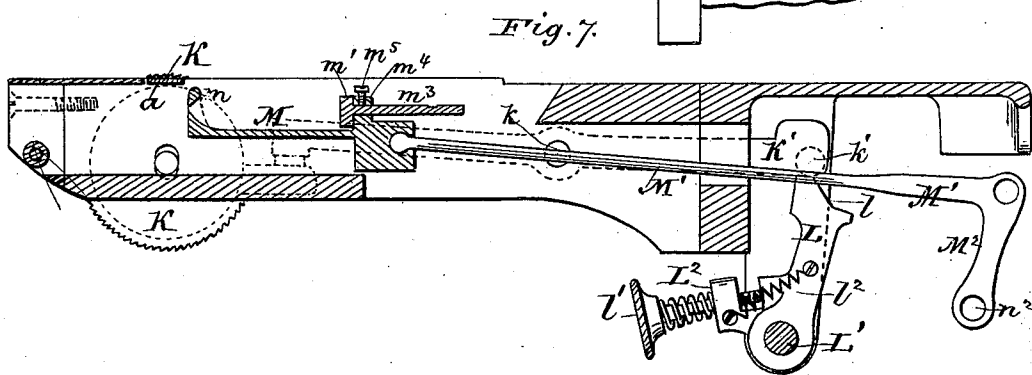
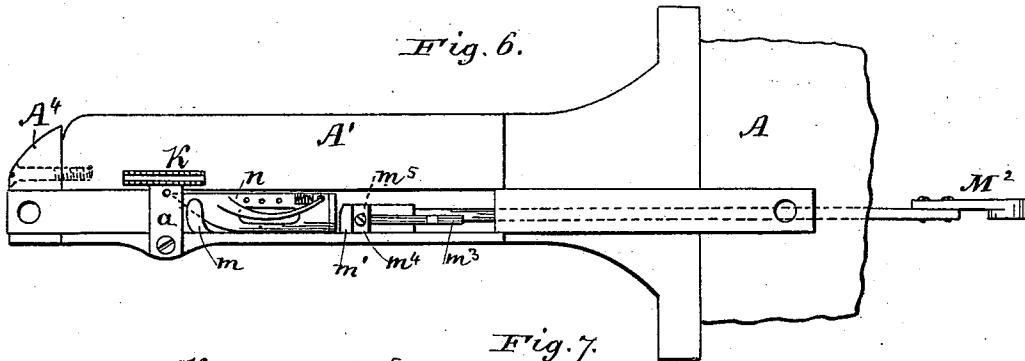
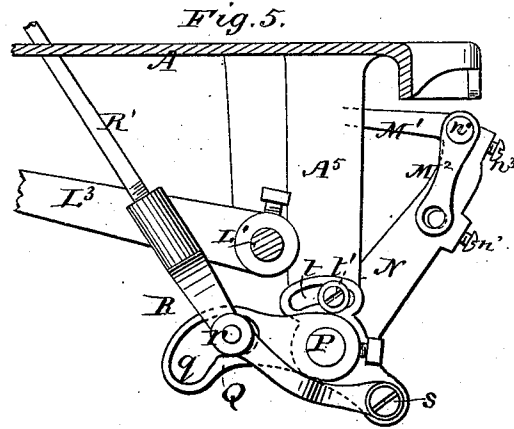
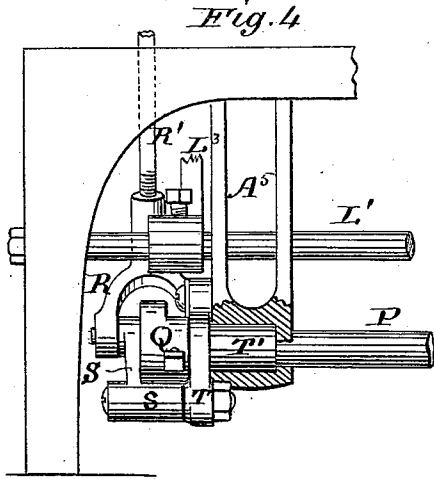

Witnesses:
 E. E. Masson
 W. C. Brown

Inventor:
 Ira Manning
 by E. E. Masson
 his atty.

UNITED STATES PATENT OFFICE.

IRA MANNING, OF PHILADELPHIA, PENNSYLVANIA.

SEWING-MACHINE.

SPECIFICATION forming part of Letters Patent No. 251,263, dated December 20, 1881.

Application filed September 28, 1881. (No model.)

To all whom it may concern:

Be it known that I, IRA MANNING, of Philadelphia, State of Pennsylvania, have invented certain new and useful Improvements in Sewing-Machines, of which the following is a specification.

My invention relates to sewing-machines provided with a horn or arm containing the shuttle-race and a serrated feed-wheel, said machines being mainly constructed for use upon leather; and the objects of my improvement are, first, to combine with a feed-wheel located within the horn or top of the machine an upper four-motion feed secured to the head or upper arm of the machine and adapted to advance the material operated upon at an angle of ninety degrees to the path of the feed-wheel; second, to shorten the horn or shuttle-race so that it will project as little as possible beyond the feed-wheel, and thus allow sewing to be done on various contracted parts of shoes, &c.; third, to produce an adjustable shuttle-carrier capable of receiving a long or short shuttle, to give to the shuttle-carrier a long or short course, as may be desired, and to give to the shuttle a much quicker motion in the fore part of its course while going forward and the last part while going backward by means of peculiarly connected and controlled levers, as hereinafter described. I attain these objects by the mechanism illustrated in the accompanying drawings, in which—

Figure 1 represents a perspective view of the machine. Fig. 2 is a side view of the four-motion feeding-foot and its operating-cams. Fig. 3 is a detached perspective view of said operating-cams. Fig. 4 is a rear view of that part of the machine showing the levers and arms operating and regulating the throw of the shuttle-carrier, the journal-bearing being partly in section to clearly show the journals. Fig. 5 is a vertical section of that part of the machine showing in side view the arms and levers controlling the shuttle-carrier. Fig. 6 is top view of the horn forming the shuttle-race, showing also the adjustable shuttle-carrier. Fig. 7 is a vertical section of the shuttle-race horn, showing the adjustable shuttle-carrier and its arm, and also the adjustable rocking-arm, by which the motion of the feed-wheel

within said horn is controlled. Fig. 8 is a side view of the eccentric, eccentric-strap, and a portion of the rods used to operate the shuttle and the lower feeding mechanism of the machine.

In the drawings, A represents the bed-plate of the machine. It carries the arm A^2 , having the head A^3 , of ordinary form, and within said arm and head are placed, upon the main shaft B, the eccentric C, operating the feed-wheel clutch and the shuttle-carrier, and the cam D, giving motion to the needle-arm. To the side of this cam D, I secure the cams D' and D^2 , that transmit a four-motion feed to the presser-foot E. Although I prefer to make the cams D' D^2 in one piece, they may be made separate and each one secured to the shaft B. The sole of the presser-foot E is serrated, so as to advance the material operated upon across the horn A' of the machine, being sustained by a small plate, a , secured across also and above the shuttle-course.

To give to the presser-foot E the necessary four motions it is rigidly connected to a plate, F, retained securely to one side of the head A^3 by means of screws a^2 and a^3 passing through slots f^2 and f^3 in said plate F. The slot f^2 is vertical to allow the plate F to have an up-and-down motion, but the slot f^3 is much wider than the diameter of the screw a^3 to allow the lower end of the plate F (and the feeding presser-foot attached thereto) to oscillate on the pivot-screw a^2 and be controlled by the cams actuating said plate together with the presser-foot. The lower opening, f^3 , has a vertical slot communicating upon one side with a nearly horizontal slot to allow the lower portion of the plate F to be pulled to one side, and be retained thus by a pendent projection, f^4 , extending slightly into the horizontal portion of the slot f^3 . The side plate, F, is provided with an arm, F' , extending about half-way across the rear of the head of the machine, it is then bent at right angle thereto, and carries an arm, E' , forming the head or upper portion of the presser-foot E.

To one side of the arm E' is pivoted, at e' , another arm, E^2 , having its upper end entering the lower portion of the arm A^2 of the machine between two small guide-plates, a' , se-

55

60

65

70

75

80

85

90

95

100

cured thereto and resting against the operating side or face of the cam D^2 . The angle made by the arm E^2 with the arm E' , or the amount of retraction of the presser-foot, is regulated by means of the thumb-screw e^2 passing through a lug, e^3 , on one side of the arm E' and resting against the back of the arm E^2 . The spring e^4 upon the adjusting-screw e^2 is simply to keep it from accidentally turning after it has been set.

The presser-foot E is advanced toward the needle g for a new feed of the material by means of a spring, h , secured at one end to the head of the machine and at the other to the arm E' . The advance of the presser-foot toward the needle is regulated by the screw f^5 engaging with the arm F' , and having its extremity bearing against the head of the machine. The plate F (and presser-foot) is lifted at every stitch by means of the arm f^6 , secured to the plate F , near the top thereof. The free end of the arm f^6 is made to enter between the cams D and D^2 in the path of the projecting lug or cam D' located between them, and is thus lifted thereby for an instant at each revolution of the main shaft B . The plate F is kept at the bottom of its course and the presser-foot down upon the material by a spring, i , having its lower end resting on the arm f^6 and its upper end engaged with the head A^3 of the machine. When the feeding-foot E is used to advance the material across the horn A' the ordinary presser-foot arm H is lifted either by the handle h' or by the operator's knee by means of the long lifter-lever H' , pivoted to the arm A^2 of the machine, the lower end of said arm H being provided either with a flat pressure-foot or presser-wheel, h^2 . After being lifted it is turned to one side, as shown in Fig. 1.

When it is desired to sew temporarily in a direction parallel with the axis of the horn the side plate, F , (and with it the presser-foot E), is lifted and its lower end swung to one side until the screw a^2 , having entered the horizontal portion of the slot f^3 , is retained by the pendent projection f^4 in said slot, and the presser-foot E is out of the way of the path of the material. If it is not desired to use the presser-foot E , it can be taken off the machine by simply removing the screw e^5 .

When it is desired to have the presser-foot H h^2 jump up at every stitch and relieve the material while the needle is therein, so that said material may be turned and uniform stitches be produced upon a curve, the arm I is secured to the plate F , so that it will strike at each stitch under the lower branch of the lifting-lever H' , causing the upper branch to engage under the plate H^2 , secured to the upper end of the presser-foot lever H , and make it jump up for an instant.

In connection with the presser-foot H h^2 , the material operated upon is advanced by a serrated feed-wheel, K , placed within the horn, as usual. This feed-wheel and its clutching

mechanism are shown in detail in the Patent granted to me March 23, 1875, No. 161,250. This wheel is intermittently rotated by means of clutches actuated by lever K' , pivoted to the horn A' at k , and having at the rear end thereof a roller, k' , adapted to slide (more or less, according to the length of stitch desired) along the incline l on the upper end of the oscillating arm L . Said arm being mounted loosely upon the shaft L' , its inclination is regulated by means of a thumb-screw, l' , passing through a short arm, L^2 , secured to the shaft L' , the arms L and L^2 being retained in an adjustable position toward each other by the spring l^2 . The shaft L' is rocked by means of the arm L^3 , having at the extremity thereof a vertical connecting-rod, L^4 , united to the eccentric C upon the main shaft B .

The above description relates mainly to means for feeding the material to be operated upon either lengthwise or crosswise of the supporting-horn; but the stitching has often to be on curved lines upon various parts of boots and shoes in many contracted or cramped situations where it is important to have the extremity of the horn as close to the needle as possible. To meet the requirements of the trade upon that point the horn is made at least one inch shorter than formerly, and it is cut transversely in two pieces, so as to be capable of being reduced three-quarters of an inch shorter still, the end piece, A^4 , being screwed to the end of the piece A' . When the two parts A' and A^4 are united an ordinary shuttle about two inches long may be used in the race-course thus produced; but if the end piece, A^4 , is removed a much shorter shuttle must be used.

To accommodate either of the shuttles the shuttle-carrier M is made adjustable. The front end, m , thereof is in one piece with the bottom of said carrier, but the rear support of the shuttle n is formed by the head m' of a rod, m^3 , passing through a lug, m^4 , in the heel of the shuttle-carrier, and a screw, m^5 , inserted in said lug retains the rod m^3 , with its head m' , close to the rear end of the shuttle, whatever may be its length. As a short shuttle requires to travel less than a long shuttle, the connecting-rod M' of the shuttle-carrier terminates at its rear end in a bell-crank or angular arm, M^2 , by which it is connected with the operating-arm N , secured to the oscillating shaft P . When a long shuttle is used the pin n' , uniting the shuttle-carrier connecting-rod M' with the arm N , is inserted in the upper hole of the angular arm M^2 and also in the upper hole of the arm N . When a short shuttle is used the pin n' is removed from the upper hole above stated and inserted into the lower hole, n^2 , of the angular arm N^2 and the corresponding hole in the lever N , screws n^3 inserted in the lever N retaining the pin n' in either one of the holes mentioned. The throw of the shuttle-carrier will correspond with the arc of a circle described by the pin n' in either hole of the arm N .

When the material operated upon is fed across the horn A' by the foot E, and the presser-foot H h^2 is lifted out of contact with the material, the feed-wheel K does not interfere materially with the operation; but the journal of the wheel K passing through a slot in the horn A', its periphery can be lowered even with the top of said horn, and its rotation can be substantially arrested by setting forward the feed-regulating screw l' until the lever L ceases to actuate the clutch-lever K'.

It is desirable that the upper and lower threads of a sewing-machine should be drawn at the same speed, so that the crossing of the threads will be in the interior of the material, and a perfect stitch be produced. This is accomplished in this machine by means of levers having an irregular motion, although receiving motion from the ordinary eccentric, C, having a uniform periphery, and the shuttle is driven rapidly forward through the loop of the needle while the latter is resting, and at a slower speed the balance of the course, or while the needle is going up. This irregular motion of the shuttle is produced as follows: Upon one extremity of the oscillating shaft P is secured an arm, Q, provided with an angular slot, g , through which passes a roller, r , placed between the forked ends R of the connecting-rod R', through which motion is transmitted from the cam C upon the main shaft B. While the roller r acts within the upper part of the slot g , it rapidly forces the arm Q downward and the upper end of the shuttle operating arm N forward. The roller r enters then the vertical portion of the slot g and moves the lever R very little farther down. When the roller r returns to its uppermost position within the slot the motion of the arm Q is more regular, and the motions of said arm Q are repeated for every stitch—that is, quickly at first, while the needle is down, and then with about the same speed as the needle, while the latter is being removed from the material. The lower end of the connecting-rod, R', or the roller r , is kept in proper relation with the oscillating shaft P and its arm Q by means of a forked link, S, pivoted at s , upon the lower end of an arm, T, having a hollow journal, T', surrounding the axle P within the pendent bearing A⁵. The upper end of the arm T is slotted at t , and is adjustably secured to the bearing A⁵ by means of the screw l' passing through the slot t . By this arrangement of levers the length of the throw or course of the shuttle can be adjusted with much precision, to make up for wear or for other causes. When the pivot s or lower end of the arm T is lowered it advances the roller r toward the vertical portion of the slot g , that is capable of receiving but little motion from said roller or from the cam C at the upper end of the rod R', and consequently the shuttle travels a shorter distance than when the pivot s is set at its highest point. The space on each side of the horn can be closed,

as usual, with a platform for general sewing and harness and carriage work. When the platform is removed the horn or shuttle-race arm will receive the smallest congress-gaiter upper, and by means of the feed-wheel and the cross-feed foxed gaiters can be stitched without turning them inside out, new gores can be stitched in old shoes, and boots can be stitched lengthwise and around the top without removing them from the horn.

Having now fully described my invention, I claim—

1. A sewing-machine provided with a four-motion feeding mechanism suspended from the head of the machine and a feed-wheel mechanism located under the top plate of the machine, each feeding mechanism being capable of acting independently of the other and operating at an angle to the other, substantially as and for the purpose described.

2. In combination with the main shaft B, arm A², and head A³ of a sewing-machine, the cams D' and D² upon said shaft, plate F, pivoted to said head, and presser-foot E, adapted to operate parallel with the axis of the main shaft, substantially as and for the purposes described.

3. The combination of the head of a sewing-machine and shaft provided with cams D' D², plate F, provided with slot f^3 and projection f^4 , and arms f^6 , F', E', and E², with spring h , secured to the head of the machine, substantially as and for the purpose described.

4. In combination with the horn A' and stitching mechanism of a sewing-machine, the plate F, pivoted to the head of the machine, and serrated presser-foot adapted to operate across the top of said horn and be retained at a distance above said horn, substantially as and for the purpose described.

5. The combination of the horn A' of a sewing-machine provided with a shuttle-race with a shuttle-carrier, M, and adjustable rod m^3 , provided with a head, m' , adapted to rest against the heel of the shuttle, substantially as and for the purpose described.

6. The combination of the horn A' of a sewing-machine with a shuttle-carrier having means to adjust its length, and the rod of said shuttle-carrier provided with a bell-crank or angular arm, M², substantially as and for the purpose described.

7. The combination of the horn A' of a sewing-machine with a shuttle-carrier having means to adjust its length, the rod M' of said shuttle-carrier provided with an angular arm, M², having a pivot-pin-receiving hole at the top and bottom thereof, and an operating-arm, N, having corresponding holes at unequal distances from the pivotal shaft thereof, substantially as and for the purpose described.

8. The combination of the frame and shaft B of a sewing-machine, its eccentric C, and rod R', having a roller, r , at the lower end thereof, with the shuttle-operating arm N, its shaft

P, slotted arm Q, adjustable arm T, and link S, substantially as and for the purpose described.

5 9. The combination of a shuttle-carrier made adjustable in regard to its length and a shuttle-carrier rod constructed to move the shuttle-carrier different distances, as may be desired, with a sewing-machine horn having its

outer end removable or its length adjustable, substantially as and for the purposes described. 10

IRA MANNING.

Witnesses:

W. K. SHRYOCK,
H. KENNEDY.