

J. B. STRAUSS.

BRIDGE.

APPLICATION FILED DEC. 18, 1905.

995,813.

Patented June 20, 1911.

3 SHEETS-SHEET 1.

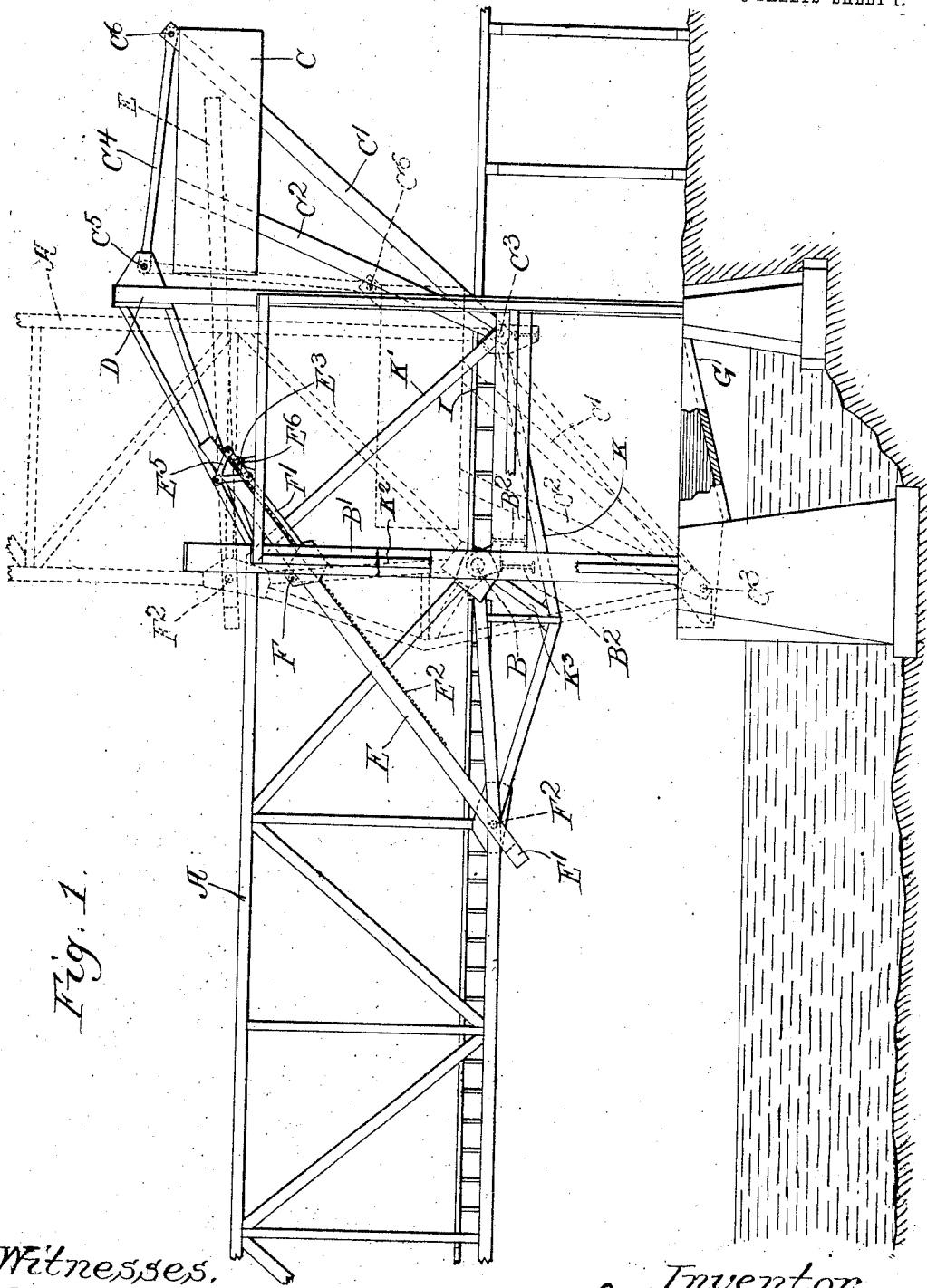

Fig. 1.

Witnesses,

Edward T. Neay.
Homer L. Craft

Inventor,
Joseph B. Strauss
by Parker & Carter
Attorneys.

J. B. STRAUSS.

BRIDGE.

APPLICATION FILED DEC. 18, 1905.

995,813.

Patented June 20, 1911.

3 SHEETS—SHEET 2.

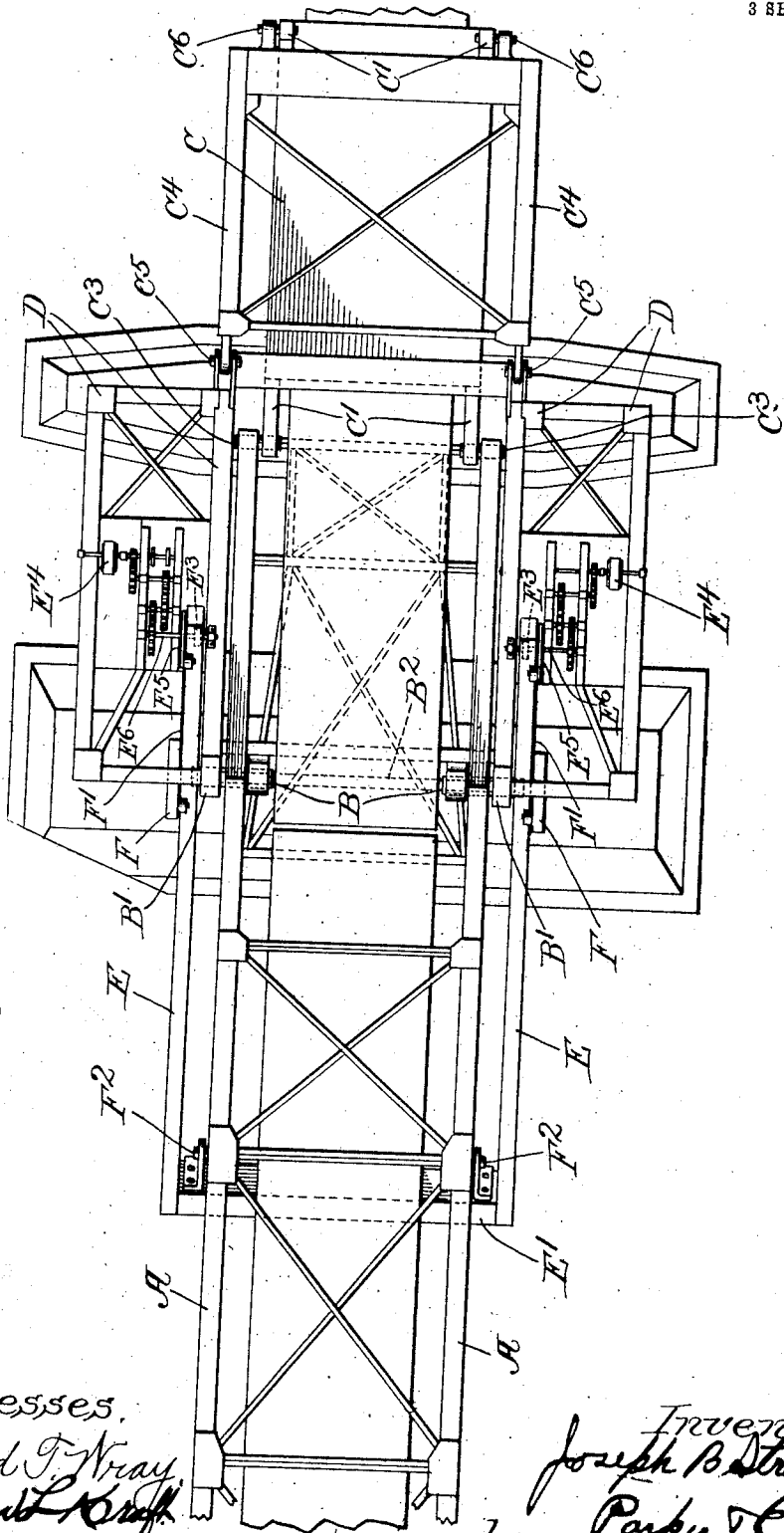

Fig. 2.

Witnesses,
Edward T. Wray,
Hornell Kniff.

Inventor,
Joseph B. Strauss,
Parker & Carter
Attorneys.

J. B. STRAUSS.
BRIDGE.

APPLICATION FILED DEC. 18, 1905.

995,813.

Patented June 20, 1911.

3 SHEETS-SHEET 3.

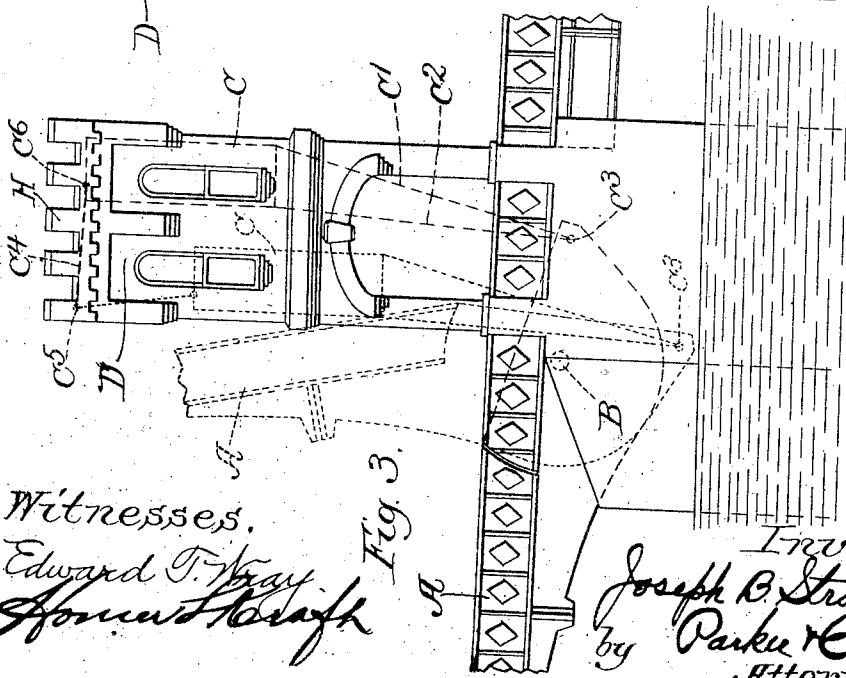
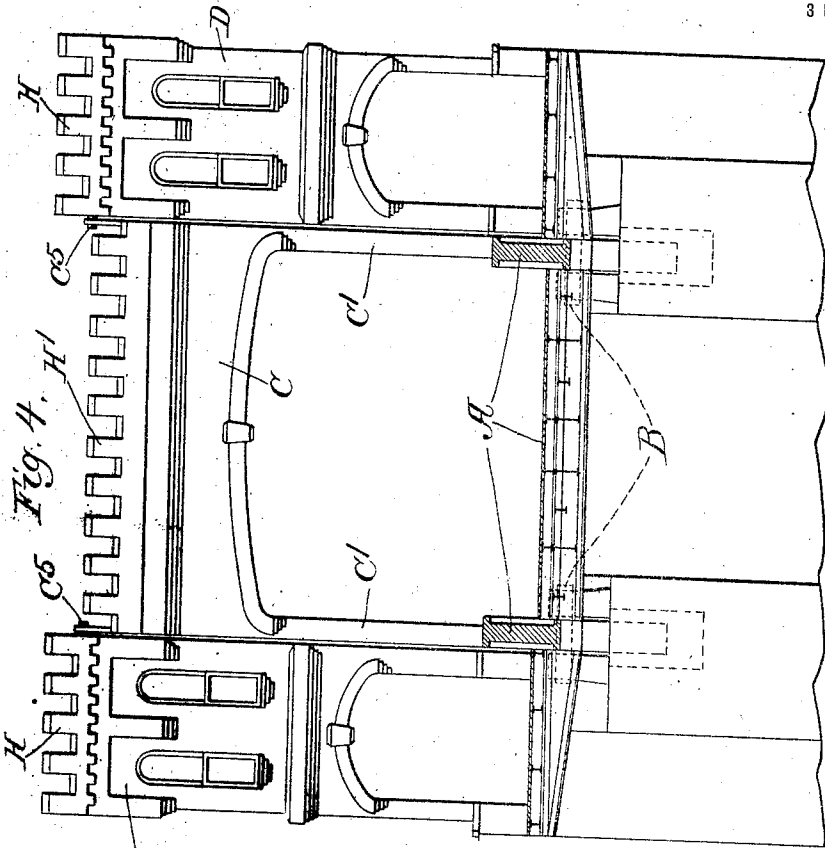

Witnesses,
Edward T. Gray
Howard Kraft

Fig. 3.

Inventor,
Joseph B. Strauss
by Parker & Carter
Attorneys

UNITED STATES PATENT OFFICE.

JOSEPH B. STRAUSS, OF CHICAGO, ILLINOIS, ASSIGNOR TO THE STRAUSS BASCULE AND CONCRETE BRIDGE COMPANY, OF CHICAGO, ILLINOIS, A CORPORATION OF ILLINOIS.

BRIDGE.

995,813.

Specification of Letters Patent. Patented June 20, 1911.

Application filed December 13, 1905. Serial No. 292,208.

To all whom it may concern:

Be it known that I, JOSEPH B. STRAUSS, a citizen of the United States, residing at Chicago, in the county of Cook and State of Illinois, have invented a certain new and useful Improvement in Bridges, of which the following is a specification.

My invention relates to bridges and particularly to bascule, and has for its object to provide a new and improved bridge of this description.

My invention is illustrated in the accompanying drawings, wherein—

Figure 1 is a side elevation of a bridge embodying my invention; Fig. 2 is a plan view of the device shown in Fig. 1; Fig. 3 is a side elevation with parts omitted showing a modified construction; Fig. 4 is an end view of Fig. 3.

Like letters refer to like parts throughout the several figures.

Referring now to the drawings, A is the movable leaf, span or section extending across the part to be bridged. This movable section may be made up in any desired manner, and is mounted upon a support so that it may be lifted to open the way spanned by the movable section. The movable section has a rearwardly projecting part which extends to the rear of the points where it is supported. As herein shown, the stationary supporting parts B¹ are provided, one on each side of the roadway to which are riveted the cross girders B² carrying the trunnions or bearings B on which the movable section rests and turns. Associated with the movable section is a counterweight C which may be of any desired construction. This counterweight is provided with connecting pieces C¹ and C², by means of which it is connected to the end of the movable section by a pivotal connection C³. The counterweight C is also connected by links C⁴ with a stationary supporting device projecting above the roadway. As herein shown, there are two such devices, D, one on each side of the roadway. It will thus be seen that the counterweight ordinarily stands up above the roadway, and that it is pivotally connected to the movable section A, and that it is also pivotally connected to the upwardly projecting stationary supports or towers D extending up above the roadway. These stationary supporting devices D are

preferably arranged so that the movable section when lifted passes up between them. The counterweight at the same time passes downwardly and inwardly between them.

Some suitable apparatus is used to operate the movable section. As herein shown, this apparatus consists of the operating struts E which are connected at one end with the movable section in any desired manner, as, for example, by being connected with the cross girder E¹ running transversely across the movable section and underneath it. These operating struts are provided on their under surfaces with racks E² which are engaged by pinions E³ operatively connected with suitable motors E⁴. These operating struts pass through frames E⁵ which are pivoted on the pinion shafts E⁶ so as to be free to rock as the position of the struts varies. A compensating counterweight F is connected with each operating strut, said counterweight being connected by a link F¹ with the frame E⁵, the link being pivoted thereto. The compensating counterweight is mounted upon the strut so that the strut can move with relation to it, and this compensating counterweight therefore varies in position with relation to the strut so as to balance, as it were, the upwardly projecting end thereof as the strut is moved upwardly to lift the movable section. As the strut passes back its free end overhangs the pinion while the length and weight of the end attached to the movable section decreases in respect to the pinion so that there would ultimately be an uplift at point F². The counterweight, however, remains constant in relation to the pinion, and its mass is such that it overbalances the strut in its extreme position and thus keeps the effect on both the movable section and pinion constant. When it is desired to lift the movable section the motors are operated, and by means of the pinions and racks the struts are moved so as to pull the movable section upwardly moving it above the trunnion connections. When the bridge is completely lifted the movable section and counterweight take the position shown in dotted lines in Fig. 1. In this construction the connecting piece C⁴ is equal in length to the distance between the center of the trunnion B and the pivot C³ and is parallel to a line drawn through these two points. Also a line drawn through the

points B' and the pivotal point C' of the connection C' (see Fig. 1) is equal and parallel to a similar line drawn through the point C' and point C'. These lines with the two fixed points B and C' and two moving points C' and C' form the elements of a parallel motion so that as the movable section rises and moves in toward the trunnion the counterweight descends and moves in toward the trunnion in equal ratio, and thus the counterweight arm remains constant and the center of gravity remains in the center of the trunnion keeping the bridge in equilibrium throughout its movement.

I prefer to provide a means for protecting the end of the bridge from extreme high water, that is, to prevent the end of the bridge from dipping down into the water when the movable section is lifted. As shown in Fig. 1, for example, this result is secured by providing a casing G supported upon the piers or bridge supports and arranged so that the end of the bridge can pass down into it. This casing may be made of any desired material, such as concrete steel, or the like, and is provided with an automatic drip which allows all water that may accumulate thereon on account of rain or the like to escape. It will be seen that in case of high water this casing will provide a pit, as it were, for the rear end of the movable section, and thus protect it from the water. As will be seen the bottom of the casing is above the normal level of the water.

In Figs. 3 and 4 I have shown a modified construction wherein the counterweight and the supporting devices therefor are used for the purpose of producing an ornamental design. The parts of this construction are similar to those illustrated in Fig. 1, except that the supporting parts D are provided with some suitable ornamental design, H, and the counterweight C is located so as to bridge the space between the parts D and is also provided with some suitable ornamental design H'. The counterweight C in this case is preferably thinner and deeper and is arranged so that when the bridge is down the counterweight cooperates with the supporting parts so as to form a unitary design, as, for example, by having its face flush with the edges thereof. The counterweight C is shown in Fig. 3 in dotted lines, and is provided with connecting pieces C' and C'' pivoted to the end of the movable section, and also the connecting pieces C' at the top connecting the counterweight with the supporting devices D. The other parts of the bridge are similar to those shown in Fig. 1, and I have not, therefore, illustrated them in detail.

The floor of the main span ends at the trunnions and the floor, I, of the approach

from the shore end to this point is fixed. The trunnions B, which as before stated are supported upon the stationary cross girders B' form the pivotal points about which the bridge turns. It will thus be seen that if the truss members of the main span extended back beyond the trunnions they would engage these cross girders B' as the bridge was turned up, and thus prevent its further movement. In order to prevent this the main truss members end at the trunnions, and the rear end of the main span is provided with truss members K, K', K'', K''' which completely surround the cross girders B', that is the cross support for the main span. The truss member K' projects downwardly and forwardly and the truss member K projects from the rear end of the bridge downwardly and is engaged by the truss member K' and then passes upwardly to the main span. It will be seen that by this construction the cross support for the main span or movable section does not in any manner interfere with the lifting of the bridge.

In constructing the counterweight I prefer to first construct a box of suitable size and shape open so the interior is accessible. The box is then filled in with loose counterweight material of any suitable kind. I may, for example, first place in the box large pieces of material and then fill in the interstices with smaller pieces or fine material until the total weight of box and material and associated parts provide the desired weight. By means of the connections herein shown the box is prevented from tilting as the bridge is lifted and lowered, and hence the spilling of the counterweight material prevented. When the bridge is closed the counterweight is high enough above the roadway to leave a passageway beneath for vehicles and persons. When the bridge is opened the counterweight lowers to substantially the level of the roadway so as to act as a barrier across the roadway.

It will be noticed that the counterweight is associated with and supported by a compound lever having a member pivoted to a fixed support, and a second member pivoted to said first member at one end and to the shore or rearwardly projecting end of the bridge span at its other end, and that one of said lever members is substantially parallel to a line which passes through the pivot of the bridge span and the point of pivotal attachment of the second lever member to said bridge span, and the other lever member substantially parallel to a line through the said pivot of the bridge span and the point of pivotal attachment of said first lever member to its support.

It will be noted that the counterweight is separated by a considerable space from the bridge itself, that is, from the main girders,

- said counterweight being at a considerable height above them. It will further be noted that the counterweight moves in a curve between the clearance line of the bridge and the roadway as the bridge opens, that is, the path of the counterweight is a curve extending from the clearance line of the bridge toward the roadway. The counterweight is suspended from or attached to a fixed part, and also to a movable part.
- I claim:
1. A bridge comprising a movable section, a counterweight therefor, a supporting device for the counterweight extending upwardly above the roadway, a pivotal connection from said counterweight to the end of said movable section back of the point about which it moves and a second pivotal connection from said counterweight to said supporting device.
 2. A bridge comprising a movable section, a counterweight therefor, a supporting device for the counterweight projecting up above the roadway, a connection extending downwardly from said counterweight and pivoted to the end of the movable section, a second connection leading from the counterweight and pivoted to the said supporting device above said counterweight.
 3. A bridge comprising a movable section having a pivotal connection with a supporting device, the rear end of said section projecting past said pivotal connection, said supporting device extending upwardly above the roadway, means for moving the said section about said pivotal connection, a counterweight for said movable section and pivotally connected to the movable section at its extended rear end and the upwardly extending part of the said support.
 4. A bridge comprising a movable section, a counterweight therefor and a parallel link mechanism for said counterweight comprising at least two movable members connected together so as to be parallel to each other in all of their various positions.
 5. A bridge comprising a movable section, a counterweight therefor, two supports for the counterweight one on each side of the roadway and projecting thereabove, said counterweight carried upon the movable section and extending across the roadway so as to form a portal over said roadway.
 6. A bridge comprising a movable section, an overhead counterweight therefor, fixed supports on each side of the roadway, the counterweight mounted upon the movable section and connected with said fixed supports so as to form a portal across the roadway.
 7. A bridge comprising a movable section, a fixed support extending above the roadway, a counterweight extending across and above the said roadway and connected with said fixed support and mounted upon said movable section so as to leave a passageway beneath it when the bridge is closed.
 8. A bridge comprising a movable section, a fixed support extending above the roadway, a counterweight carried upon the movable section and extending across and above the said roadway and connected with said fixed support and said movable section so as to leave a passageway beneath it when the bridge is closed, mechanism for moving said movable section and counterweight so as to open the bridge, said counterweight acting as a barrier across the roadway when the bridge is open.
 9. A bridge comprising a movable section, a stationary cross support therefor, the rear end of the movable section having truss members which completely surround the said cross support.
 10. A bridge comprising a movable section, two upright supports therefor, one on each side of the roadway, a stationary cross support connected with said upright supports and upon which the movable section is mounted the main trusses of the movable section ending at the said cross support, the rear end of the movable section having truss members above and below said cross support and arranged so as to at all times be free from the cross support when the movable section is lifted.
 11. A bridge comprising a movable section, an ornamental portal associated therewith, a portion of said portal movably held in position and a rigid connection between said movable portion of said portal and said movable section so that said portal acts as the counterweight for the movable section.
 12. A bridge comprising a movable section mounted upon trunnions and having a rearwardly projecting end, a counterweight therefor located above the roadway when the movable section is in its operative position, and a connection between said counterweight and said rearwardly projecting end of the movable section.
 13. A bridge comprising a portal located above the roadway leading to the bridge and extending thereacross, a rigid connection from said portal to said movable section whereby said portal acts as a counterweight for said movable section.
 14. A bridge comprising a movable section, a box above the roadway and extending thereacross and pivotally connected with the end of said section and containing counterweight material and means for preventing the tilting of said box as the movable section is lifted so as to prevent the spilling of the counterweight material.
 15. A bridge comprising a movable section, a box connected with said movable section and located above the roadway, and containing removable counterweight material, and a connection from said box to a sta-

tionary part arranged to prevent said box from tilting when the movable section is lifted.

16. A bridge comprising a movable section, an ornamental device located above the roadway and a rigid connection between said ornamental device and said movable section, said ornamental device acting as the counterweight therefor.

17. A bridge comprising a movable section, stationary supports extending thereabove, a counterweight connected to said supports and to the movable section, the connection between the counterweight and said supports being pivoted both to the counterweight and the supports.

18. A bridge comprising a movable section, a stationary part, an operating mechanism comprising an operating strut connected with the movable section and the stationary part, a motor mechanism operatively connected with said operating strut so as to move it to lift the movable section, and means for preventing the weight of said strut from unbalancing the movable section.

19. A bridge comprising a movable section pivoted between its ends and having a rearwardly projecting part projecting beyond the pivotal points, a support extending above the roadway, a counterweight

mounted upon the rearwardly projecting end of the movable part and movably connected with said support.

20. A bridge comprising a movable section, an operating strut connected therewith, a rack on said operating strut, a pinion engaging said rack, a motor mechanism operatively connected with said pinion, and a counterweight for said strut movably mounted thereon.

21. A bridge comprising a movable section mounted upon pivots and provided at each side with a truss, a counterweight above the roadway pivotally connected to both trusses of said movable section so as to vary its distance from the pivots upon which said movable section is mounted as said section is lifted and lowered.

22. A bridge comprising a movable section, a counterweight therefor above the clearance line of the bridge a rigid connection between said counterweight and the bridge, said counterweight held in position so that it moves in a curve extending from the clearance line of the bridge toward the roadway when the bridge is open.

JOSEPH B. STRAUSS.

Witnesses:

HOMER L. KRAFT,
EDNA K. REYNOLDS.