

(19) World Intellectual Property Organization
International Bureau



(43) International Publication Date
31 August 2006 (31.08.2006)

PCT

(10) International Publication Number
WO 2006/091606 A2

(51) International Patent Classification:
E04F 13/08 (2006.01) *E04F 21/22* (2006.01)
E04F 21/18 (2006.01)

(21) International Application Number:
PCT/US2006/006134

(22) International Filing Date:
21 February 2006 (21.02.2006)

(25) Filing Language: English

(26) Publication Language: English

(30) Priority Data:
10/906,478 22 February 2005 (22.02.2005) US
11/307,678 16 February 2006 (16.02.2006) US

(71) Applicant (for all designated States except US): **DAVINCI ITALIA/USA GROUP, LLC** [US/US]; 100 W. Burlington, Fairfield, IA 52556 (US).

(72) Inventors; and

(75) Inventors/Applicants (for US only): **KUFNER, Edward, A.** [US/US]; P.O. Box 108, Fairfield, IO 52556 (US). **VOLPONI, Michele** [IT/US]; 110 1/2 South Main Street, Fairfield, IO 52556 (US).

(74) Agent: **STREIT, Richard, J.**; Ladas & Parry LLP, 224 South Michigan Avenue, Chicago, IL 60604 (US).

(81) Designated States (unless otherwise indicated, for every kind of national protection available): AE, AG, AL, AM, AT, AU, AZ, BA, BB, BG, BR, BW, BY, BZ, CA, CH, CN, CO, CR, CU, CZ, DE, DK, DM, DZ, EC, EE, EG, ES, FI, GB, GD, GE, GH, GM, HR, HU, ID, IL, IN, IS, JP, KE, KG, KM, KN, KP, KR, KZ, LC, LK, LR, LS, LT, LU, LV, LY, MA, MD, MG, MK, MN, MW, MX, MZ, NA, NG, NI, NO, NZ, OM, PG, PH, PL, PT, RO, RU, SC, SD, SE, SG, SK, SL, SM, SY, TJ, TM, TN, TR, TT, TZ, UA, UG, US, UZ, VC, VN, YU, ZA, ZM, ZW.

(84) Designated States (unless otherwise indicated, for every kind of regional protection available): ARIPO (BW, GH, GM, KE, LS, MW, MZ, NA, SD, SL, SZ, TZ, UG, ZM, ZW), Eurasian (AM, AZ, BY, KG, KZ, MD, RU, TJ, TM), European (AT, BE, BG, CH, CY, CZ, DE, DK, EE, ES, FI, FR, GB, GR, HU, IE, IS, IT, LT, LU, LV, MC, NL, PL, PT, RO, SE, SI, SK, TR), OAPI (BF, BJ, CF, CG, CI, CM, GA, GN, GQ, GW, ML, MR, NE, SN, TD, TG).

Published:

— without international search report and to be republished upon receipt of that report

For two-letter codes and other abbreviations, refer to the "Guidance Notes on Codes and Abbreviations" appearing at the beginning of each regular issue of the PCT Gazette.

(54) Title: TILE ALIGNMENT AND LEVELING DEVICE AND METHOD FOR USING SAME

(57) Abstract: A device for aligning and leveling tiles as they are laid in floors, walls, countertops, or the like. The device has a top plate with several spacer fins and a bottom plate. The plates are combined with a shaft that extends from the bottom plate through the top plate so that the top plate is movable along the length of the shaft. In use, the device is placed between adjacent tiles so that the top and bottom plates hold adjacent tiles at a desired height as the setting bed dries.

WO 2006/091606 A2

TILE ALIGNMENT AND LEVELING DEVICE
AND METHOD FOR USING SAME

RELATED APPLICATIONS

This patent application is a Continuation-in-Part of U.S. patent application serial number 10/906,478 filed on February 22, 2005 which is hereby incorporated by reference.

BACKGROUND OF THE INVENTION

This invention is directed to the field of laying and leveling tile and slabs. More particularly, the invention is directed to a device for aligning and leveling adjacent tiles as they are laid in floors, walls, countertops, or the like.

Tile has become a popular decorative and functional article for use in floors, walls, countertops, and the like. Both professional tile installers and do-it-yourselfers spend a great deal of time aligning and leveling tiles as they are being placed on a substrate's surface. Proper alignment and leveling of each tile is important for a number of reasons. One reason is that if one tile is improperly placed, the error will continue in adjacent tiles such that the installation will be unacceptable and the tiles will

have to be replaced and/or ground and polished until the tiles are level or flat. In addition to aesthetic reasons for properly laying tile, a level surface is essential in tile floors so that people do not trip and fall on unevenly laid tiles. Replacing or otherwise correcting errors in tile installation takes time that adds to the total cost of the tile installation.

Laying and leveling tile can be difficult because many substrates are uneven, such as the ground substrate when laying tile for an outdoor patio. In this case, it can be difficult to raise the low areas of the substrate with mortar or other objects so that all the tiles are level. Further, tiles can shift and sink into mortar as the mortar dries. It is therefore necessary to continually monitor newly laid tiles as the mortar dries to ensure that they remain level. If some of the tiles begin to sink into the mortar, it can be difficult to raise the sinking tiles without disturbing the adjacent tiles.

Tile installers have used a variety of methods to maintain quality tile installation while completing the installation process as fast as possible. One basic method uses markings on the substrate surface. Marking the installation surface requires the mortar to be carefully applied such that the marks remain visible. Although this technique aids in the alignment of the tiles, it does not keep the tiles level as they are laid in the mortar. Further, the use of this marking technique increases the amount of time required for the installation which results in increased cost.

Another device used for laying and leveling tile is a frame designed to space tiles an appropriate distance. This type of frame is typically a fixed grid which is designed for a specific tile size. The disadvantage of this type of device is that it is a fixed size

which requires a professional installer to carry multiple frames in order to be capable of installing any tile size. A further disadvantage of this type of frame is that it is only capable of installing one type of tile at a time.

Another device used to lay and align adjacent tiles is a spacer such as the one described in U.S. Patent Number 6,625,951 (McCarthy). The spacer disclosed in this patent provides a square edge for properly aligning adjacent tiles at right angles, and a height adjustment means for adjusting the height of the tiles relative to the mortar surface. One problem with this device is that it is difficult to set multiple spacers to the same height which often results in an uneven tile surface. A related problem with this device is that the adjustment means does not allow the height of the tiles to be adjusted after the tile is laid because the height adjustment means is located under the tile after the tile is laid.

Therefore, there is a need for an efficient and inexpensive tile leveling and alignment device that allows for the vertical adjustment of tiles relative to each other after the tiles have been laid in the mortar.

SUMMARY OF THE INVENTION

The present invention is directed to a tile leveling and alignment device for use in installing tiles on substrates such as floors, walls, countertops, or the like. The invention comprises a top plate and a bottom plate. The plates are combined with a shaft that extends from the bottom plate through the top plate so that the top plate is movable along the length of the shaft. A typical first step in laying tile is the application of a setting bed, such as a cement or mortar compound, to the substrate surface.

Thereafter, the tiles can be placed in the setting bed. During these steps the bottom plate of the present invention is positioned in the setting bed beneath the tiles so that the shaft extends upward between adjacent tiles. The bottom plate is preferably positioned so that it is in contact with more than one tile. The shaft extends from the bottom plate upward between adjacent tiles and is combined with the top plate. The top plate is movably combined with the shaft so that after the tiles are laid in the setting bed on top of the bottom plate, the top plate is moved toward the tiles until the tiles are between and in contact with both plates. The device preferably comprises a locking assembly to prevent the top plate from moving once it has been properly positioned. The plates support the tiles so that adjacent tiles remain level even if the substrate material is not level. In other words, the plates keep the tiles level relative to the adjacent tiles, not relative to the substrate surface. It is not even necessary that the bottom plate be in contact with the substrate in order for the device to achieve a level tile surface. The plates hold the tiles at the same height so that corners and/or edges of the adjacent tiles remain level in the setting bed as the setting bed dries and cures.

After the setting bed dries, thereby securing the tiles to the substrate, the shaft is separated from the bottom plate leaving the bottom plate beneath the set tiles. The top plate and the portion of the shaft above the separation point are released from the set tiles allowing the top plate to be reused in subsequent tile setting and leveling procedures.

In addition to the tile leveling feature described above, the preferred embodiment also comprises a tile spacer means for aligning adjacent tiles. The tile

spacer means is comprised of one or more vertical fins extending from the surface of the plates toward the tiles, i.e. the fins are on the lower surface of the top plate and/or the upper surface of the bottom plate. The fins are adapted to be placed between adjacent tiles so that adjacent tiles are spaced the proper distance apart. Different plates may comprise fins of different sizes so the user can choose the desired distance between adjacent tiles.

One of ordinary skill in the art would understand that a plurality of tile leveling devices can be simultaneously used between different tiles being laid on a substrate so as to level many tiles at the same time.

BRIEF DESCRIPTION OF THE DRAWING

FIG. 1 is a perspective view of the device of the present invention;

FIG. 2 is an elevational view of the device of the present invention in use between two adjacent tiles;

FIG. 3 is a perspective view of the lower side of the top plate showing the spacer fins and the sliding channel;

FIG. 4 is a perspective view of the upper side of the top plate wherein the locking assembly is combined with the top plate;

FIG. 5 is a perspective cut away view of the upper side of the top plate showing the locking assembly comprising locking tongues and tongue release;

FIG. 6 is a perspective view of an alternate embodiment of the invention wherein the shaft is threaded;

FIG. 7 is an elevational view of an embodiment wherein the bottom plate is shaped like a stair step to accommodate tiles of different thicknesses;

FIG. 8 is an elevational view of an embodiment wherein the top portion of the shaft is thicker than the bottom portion of the shaft;

FIG. 9 is an elevational view showing an embodiment wherein the top plate is separate from the locking assembly; and

FIG. 10 is a prospective view of the embodiment shown in FIG. 9 wherein the top plate is combined with the locking assembly.

DESCRIPTION OF THE PREFERRED EMBODIMENT OF THE INVENTION

The present invention is a tile 18 alignment and leveling device. The device can be used to align and level tiles 18 that are being secured to any suitable substrate, including floors, walls, and countertops. It should be noted that words used in this specification such as upper, lower, top, and bottom, are relative to the device as it is shown in FIG. 2 with the top plate 10 above the bottom plate 12.

As best seen in FIG. 1, the present invention comprises a top plate 10 and a bottom plate 12 combined with a shaft 14. The plates 10, 12 can be made from any suitable material, however, they are preferably comprised of plastic with a metal reinforcing insert embedded inside the plastic. The metal insert provides strength and rigidity to the plates 10, 12 that may be needed for leveling heavy tiles 18 or slabs, while the outer plastic portion prevents damage to the tiles 18 and does not rust.

FIGS. 4 and 5 show that the top plate 10 comprises an opening referred to as a sliding channel 24 which is adapted to receive the shaft 14. The top plate 10 is movable

along the length of the shaft 14 with the shaft passing through the sliding channel 24. The shaft 14 is preferably comprised of plastic, thereby making the shaft 14 semi-rigid.

In the embodiment shown in FIGS. 1 and 2, the shaft 14 is square with surface features 15 on all four of its sides. The surface features 15 of the shaft 14 are further described below. The square shape of the shaft 14 allows the locking assembly 33 to be combined with the shaft 14 in any of four orientations. This increases efficiency because the user does not need to spend time determining the directionality of the locking assembly 33 relative to the shaft 14 as the user slides the locking assembly 33 onto the shaft 14. In alternate embodiments, the shaft 14 has surface features 15 on only one or two of its sides. However, in these embodiments, the user may have to spend time determining which side of the shaft 14 aligns properly with the locking assembly 33. In addition to a square shape, the shaft 14 can be any other suitable shape, such as rectangular as shown in FIGS. 9 and 10, or round as shown in FIG. 6.

FIG. 2 is a side elevational view showing the device of the present invention between adjacent tiles 18. A typical first step in laying tile 18 is to apply a setting bed 20 such as mortar or cement to the substrate surface 22. After the setting bed 20 is applied, the tiles 18 can be placed in the setting bed 20. In use, the bottom plate 12 of the device is positioned in the setting bed 20 beneath the tiles 18 so that the shaft 14 extends upward between adjacent tiles 18, preferably at joint or corner locations. The shaft 14 extends from the bottom plate 12 upward between the tiles 18 and is combined with the top plate 10, which is positioned above the tiles 18. The top plate 12 is moved along the shaft 14 toward the tiles 18 until the tiles 18 are in contact with both plates 10, 12 as

shown in FIG. 2. The plates 10, 12 hold the tiles 18 at their desired height so that adjacent tiles 18 are level regardless of whether the underlying substrate material 22 is level. In other words, with the present invention the bottom plate 12 does not need to rest on the substrate in order for the tiles 18 to be level. The bottom plate 12 may even be suspended above the substrate as long as at least a portion of the tile 18 is contacting the setting bed 20 and as long as the tiles 18 are level relative to each other. The plates 10, 12 hold the tiles 18 at the same height so that corners and/or edges of the adjacent tiles 18 remain aligned and level as the setting bed 20 hardens.

Once the tiles 18 are properly positioned, it is important that the top plate 10 does not move upward along the shaft 14. To this end, the device comprises a locking assembly 33 combined with the shaft 14 above the top plate 10 which prevents the top plate 10 from moving upward along the shaft 14. In some embodiments, the locking assembly 33 comprises at least one locking tongue 30 which, together with the shaft 14, functions like a commercially available "zip tie." In other words, the locking tongue 30 allows the locking assembly 33 to move freely in a first direction (downward) along the length of the shaft 14, but not in a second direction (upward) along the length of the shaft 14. One way to accomplish this is shown in FIG. 1 wherein the shaft 14 has a plurality of horizontal surface features 15 along its length. These surface features 15 can be either indentations or elevated ridges. The locking tongue(s) 30 of the locking assembly 33, shown in FIG. 5, are angled and adapted to interfere with the surface features 15 to allow movement of the shaft 14 in only one direction. The surface

features 15 are preferably close enough together so as to provide a nearly infinite adjustment for the height of the locking assembly 33.

Another way the locking tongue(s) 30 can prevent movement in the upward direction is shown in FIG. 10 wherein the device comprises one or more vertical surface features 17. The vertical surface features 17 are preferably comprised of a plastic material similar to the shaft 14 so that the angled locking tongue(s) 30 digs into the surface features 17 and does not allow movement in the upward direction. The locking tongue(s) 30 could dig into the plastic shaft 14 directly without any surface features 14, 17; however, the vertical surface features 17 reduce the surface area into which the locking tongue(s) 30 must penetrate thereby allowing the locking tongue(s) 30 to dig deeper and hold better.

As shown in FIGS. 5, 6, 9 and 10, the locking tongues 30 may comprise tongue releases 31. Activation of the tongue release 31 enables the user to release the locking tongues 30 from the surface features 15 on the shaft 14 to allow movement of the locking assembly 33, and, thus, the top plate 10, in the second (upward) direction.

One of ordinary skill in the art will realize that the number of locking tongues 30 can vary depending on the shape of the shaft 14 and the desired holding strength of the device. Typically, an increased number of locking tongues 30 allows the locking assembly 33 to resist more force. For example, the locking assembly 33 may comprise four locking tongues 30 so that there is one tongue 30 on four different sides of the locking assembly 33. This arrangement is preferably for use with a square shaft 14 having surface features 15 on all four sides. Alternatively, as shown in FIG. 5, the

locking assembly 33 may comprise more than one locking tongue 30 per side of the locking assembly 33.

FIGS. 1, 2 and 5 show an embodiment wherein the locking assembly 33 is combined with the top plate 10 so that the top plate 10 and locking assembly 33 are one piece. FIGS. 9 and 10 show an alternate embodiment wherein the locking assembly 33 is detachable from the top plate 10 so that different top plates 10 having different sized fins 26 can be used with the same locking assembly 33. In this embodiment, top plate 10 preferably comprises members 35 which are received by openings (not shown) on the underside of locking assembly 33 to hold the top plate 10 together with the locking assembly 33 by an interference fit during use.

As best seen in FIG. 3, the lower side of the top plate 10 comprises several spacer fins 26 for spacing adjacent tiles 18 a proper and consistent distance from each other. The thickness of the spacer fins 26 may vary depending on the desired distance between adjacent tiles 18. Similarly, different plates 10, 12 having different sized spacer fins 26 may be used depending on the desired distance between adjacent tiles 18. The spacer fins 26 are preferably rectangular shaped and extend from the edge of the top plate 10 toward the center of the top plate 10. In the preferred embodiment, the top plate 10 comprises four spacer fins 26 when used at the intersection of four tiles 18, and two spacer fins 26 on either side of the sliding channel 24 when used between two tiles 18. Further, it is preferred that the spacer fins 26 extend from the edge of the plate 10 to the edge of the sliding channel 24 to reduce the opportunity for mud or mortar to seep through the channel 24. In an alternate embodiment, there are spacer fins 26 facing

upward from the upper portion of the bottom plate 12 which serve the same function as the above described spacer fins 26.

As seen best in FIGS. 1 and 6, the bottom plate 12 preferably comprises a plurality of openings 28. The openings 28 allow the setting bed material 20 to seep through the bottom plate 12. This seepage allows the setting bed material 20 to bond with the portion of the tile 18 directly above the bottom plate 12, which otherwise may not contact much of the setting bed material 20. Further, the seepage helps to ensure that the tiles 18 remain level as forces are applied to the plates 10, 12, setting bed material 20, and/or tiles 18 during tightening, leveling, and setting. If the setting bed material 20 was not allowed to seep through the bottom plate 12, the setting bed material 20 could raise the bottom plate 12 as it dried which would consequently affect the level of the tiles 18.

After the setting bed 20 dries, and the tiles 18 are secured to the substrate 22, the user removes the portion of the device that is visible above the laid tiles 18, i.e. the shaft 14, top plate 10, and locking assembly 33. To accomplish this, the shaft 14 comprises a separation point 16 near the connection of the shaft 14 and the bottom plate 12 as seen in FIGS. 1 and 2. In the preferred embodiment, the separation point 16 is structurally weaker than the remainder of the shaft 14 so that the user can twist the portion of the shaft 14 that extends above the tiles 18 and cause the shaft 14 to break at its separation point 16. Although the separation point 16 is capable of breaking when twisted, it is strong enough so that when force is applied along the length of the shaft 14, the shaft 14 does not break. Once separated at the separation point 16, the bottom plate 12 remains

below the tiles 18 and is therefore not reusable. The top plate 10 and locking assembly 33, however, can be removed from the shaft 14 and reused in subsequent tile 18 laying operations. As discussed above, the shaft 14 is preferably made of a semi-rigid plastic, and is preferably square in shape. This square shape and semi-rigid material allow the shaft 14 to more easily be broken at its separation point 16.

FIG. 6 shows an alternate embodiment preferably for use in laying tiles 18 in wall substrates 22. This embodiment also comprises a top plate 10a and a bottom plate 12a combined by a shaft 14a. In this embodiment, the top plate 10a is preferably metal with a plastic or rubber material on the bottom surface of the plate 10a. The shaft 14a in this embodiment is preferably threaded like a screw. The bottom plate 12a comprises a threaded opening into which the shaft 14a is screwed for securing the shaft 14a to the bottom plate 12a. Preferably, the opening in the bottom plate 12a is reverse threaded so that the shaft 14a does not become unscrewed from the bottom plate 12a as the nut 32 is tightened. Further, preferably, the opening in the bottom plate 12a only extends through a portion of the bottom plate 12a (not all the way through) so that the shaft 14a is secured to the bottom plate 12a, but does not penetrate or screw into the substrate 22 beneath the bottom plate 12a.

In the embodiment shown in FIG. 6, the top plate 10a is freely movable along the length of the shaft 14a. The locking assembly for this embodiment is a nut 32, preferably a wing nut, which is threaded onto the shaft 14a. As with the above described locking assemblies 33, the nut 32 prevents upward movement of the top plate 10a once properly positioned. The plates 10a, 12a are placed on either side of the tiles

18 as described in the previous embodiments, and then the nut 32 is tightened down the shaft 14a to hold the two plates 10a, 12a snugly on either side of the tile 18. After the tiles 18 are set in the setting bed 20, the screw/shaft 14a can be unscrewed from the bottom plate 12a. This allows the top plate 10a and screw/shaft 14a to be removed from the tile 18, while the bottom plate 12a remains underneath the set tile 18.

Alternatively, the screw/shaft 14a can be separated from the bottom plate 12a by using a weaker separation point 16 as described in the above embodiments.

FIG. 7 shows an alternate embodiment that can be used with any of the above embodiments. In this embodiment, the bottom plate 12 is shaped like two stairs in that there are two horizontal portions combined by a vertical portion. The top of the vertical portion is preferably where the bottom plate 12 is combined with the shaft 14. The purpose of this embodiment is so that the device can be used to lay and level two tiles 18, 18a of different thickness. This is shown in FIG. 7 wherein the device is being used to level tile 18 with thicker tile 18a.

FIG. 8 shows an alternate embodiment which can be used with any of the above embodiments wherein the upper portion 14a of the shaft 14 is thicker than the lower portion 14b of the shaft 14. The upper portion 14a of the shaft 14 is thicker so that the user can better grip the shaft 14 when tightening the top plate 10 against the tiles 18. The lower portion 14b of the shaft 14 that extends between adjacent tiles 18 toward the bottom plate 12 is thinner so that tiles 18 can be placed closer together, if desired, and so that it is easier to separate the shaft 14 from the bottom plate 12 in the embodiment comprising the separation point 16.

Having thus described the invention in connection with the preferred embodiments thereof, it will be evident to those skilled in the art that various revisions can be made to the preferred embodiments described herein without departing from the spirit and scope of the invention. It is my intention, however, that all such revisions and modifications that are evident to those skilled in the art will be included within the scope of the following claims.

CLAIMS

What is claimed is as follows:

1. A device for laying and leveling tiles, said device comprising:
 - a shaft having an upper portion and a lower portion;
 - a bottom plate combined with the shaft lower portion;
 - a top plate having an opening which is adapted to receive the shaft, said top plate having an upper side and a lower side; and
 - a locking assembly having an opening adapted to receive the shaft.
2. The device of claim 1 wherein the locking assembly is movable in a first direction along the shaft by not in a second direction along the shaft.
3. The device of claim 2 further comprising a tongue release combined with the locking assembly and adapted to allow the locking assembly to move in both the first and second directions when actuated.
4. The device of claim 1 wherein the shaft further comprises a separation point that is structurally weaker than the remainder of the shaft to allow the shaft to be separated from the bottom plate.
5. The device of claim 1 wherein the bottom plate comprises a plurality of openings.
6. The device of claim 1 wherein the bottom plate comprises two horizontal portions combined with a vertical portion to allow the device to be used between tiles of different thicknesses.

7. The device of claim 1 wherein the lower side of the top plate further comprises two spacer fins adapted for insertion between adjacent tiles.
8. The device of claim 1 wherein the lower side of the top plate further comprises four spacer fins adapted for insertion between adjacent tiles.
9. The device of claim 2 wherein the shaft is threaded.
10. The device of claim 9 wherein the bottom plate comprises a threaded opening adapted to receive the threaded shaft.
11. The device of claim 10 wherein the locking assembly is a nut, said nut adapted for tightening against the top plate as the top plate is moved in the first direction.
12. The device of claim 1 wherein the shaft upper portion is thicker than the shaft lower portion.
13. The device of claim 1 wherein the shaft is round.
14. A device for laying and leveling tiles, said device comprising:
 - a shaft having an upper portion, a lower portion, and a plurality of surface features;
 - a bottom plate combined with the shaft lower portion;
 - a top plate having an opening which is adapted to receive the shaft, said top plate having an upper side and a lower side; and
 - a locking assembly having an opening adapted to receive the shaft, wherein the locking assembly has at least one locking tongue which is adapted to interfere with the surface features on the shaft so that the locking assembly is movable in a first direction along the shaft but not in a second direction along the shaft.

15. The device of claim 14 wherein the locking tongue is angled relative to the shaft.
16. The device of claim 14 wherein the bottom plate, top plate, and locking assembly are combined with the shaft so that the top plate is between the bottom plate and the locking assembly.
17. The device of claim 14 wherein the locking assembly further comprises at least one tongue release adapted to reduce the interference between the locking tongue and the surface features so that when the tongue release is actuated the locking assembly is able to move in both the first direction and the second direction.
18. The device of claim 14 wherein the surface features are horizontal.
19. The device of claim 14 wherein the surface features are vertical.
20. A method for laying and leveling adjacent tiles using a device having a shaft with a bottom plate secured thereto and a top plate having an upper side and a lower side, said top plate being threaded onto and movable along the shaft, said method comprising:
 - applying a setting bed to a substrate material;
 - placing the bottom plate in the setting bed;
 - placing at least two tiles over the bottom plate so that the shaft extends upward between the tiles;
 - moving the top plate downward along the shaft until it is in contact with the tiles;
 - leveling the tiles using the device;
 - allowing the setting bed to dry; and

removing the top plate and the shaft from the bottom plate.

21. The method of claim 20 wherein the lower side of the top plate further comprises spacer fins which are placed between the adjacent tiles.
22. The method of claim 20 further comprising the step of removing the bottom plate from the shaft by breaking the shaft near the bottom plate.
23. The method of claim 20 wherein the shaft is threaded and the bottom plate comprises a threaded opening adapted to receive the threaded shaft; and
wherein the shaft is removed from the bottom plate by unscrewing the shaft from the bottom plate.

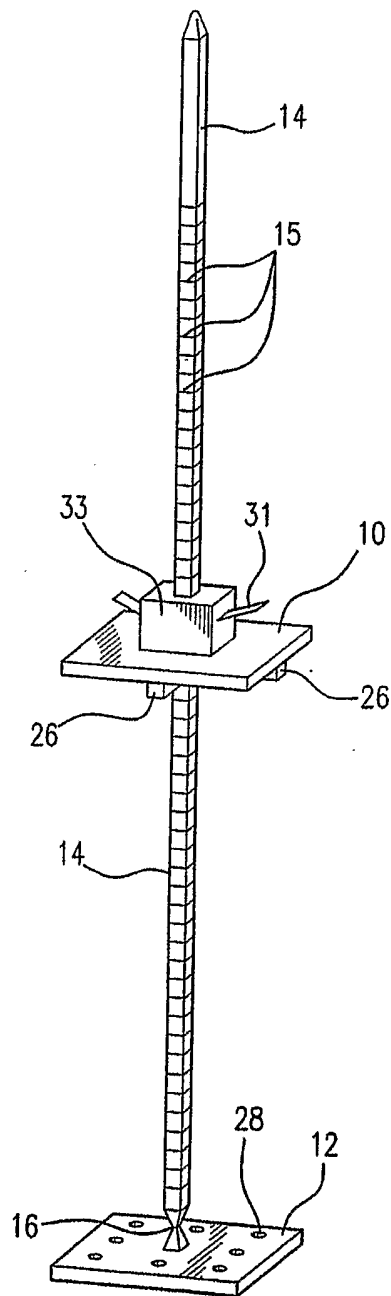

FIG. 1

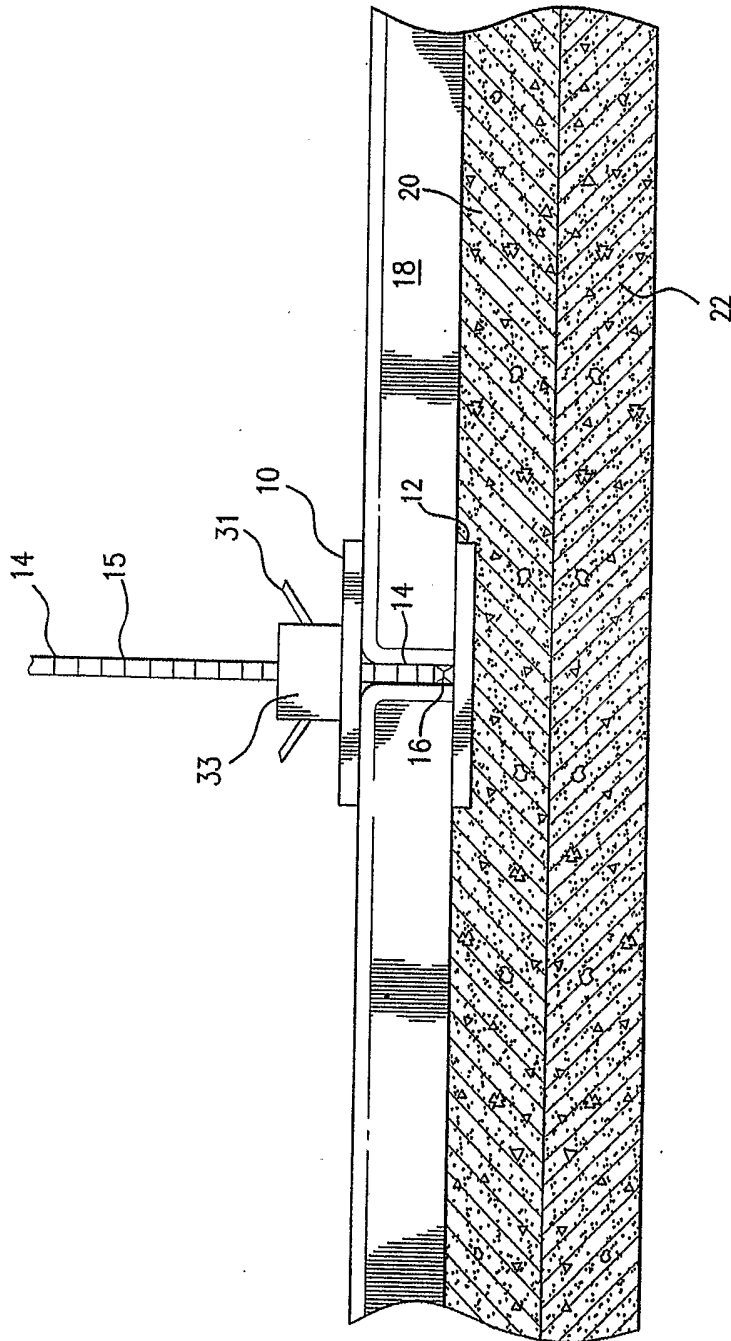

FIG.2

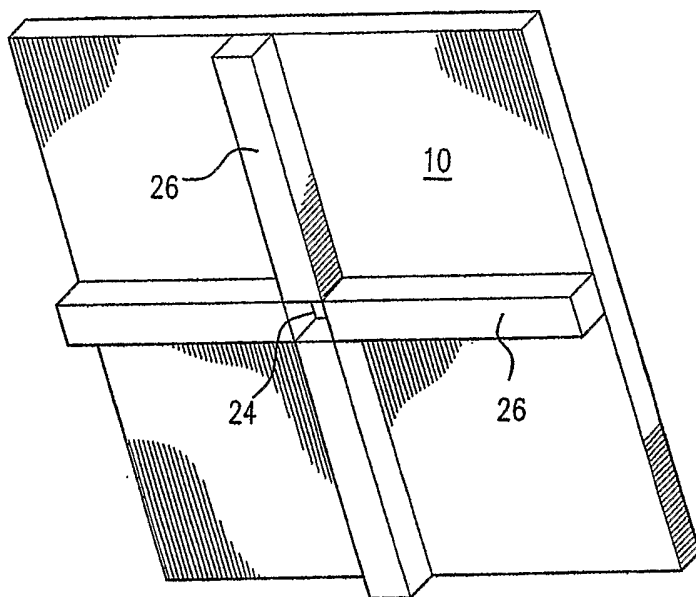

FIG. 3

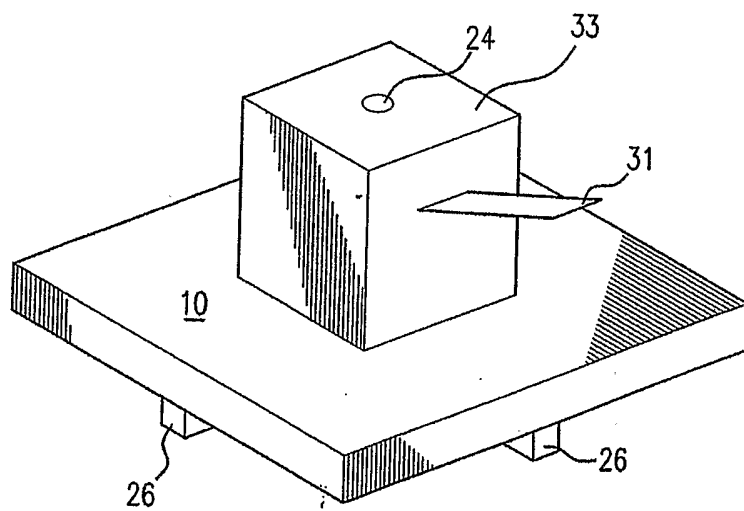

FIG. 4

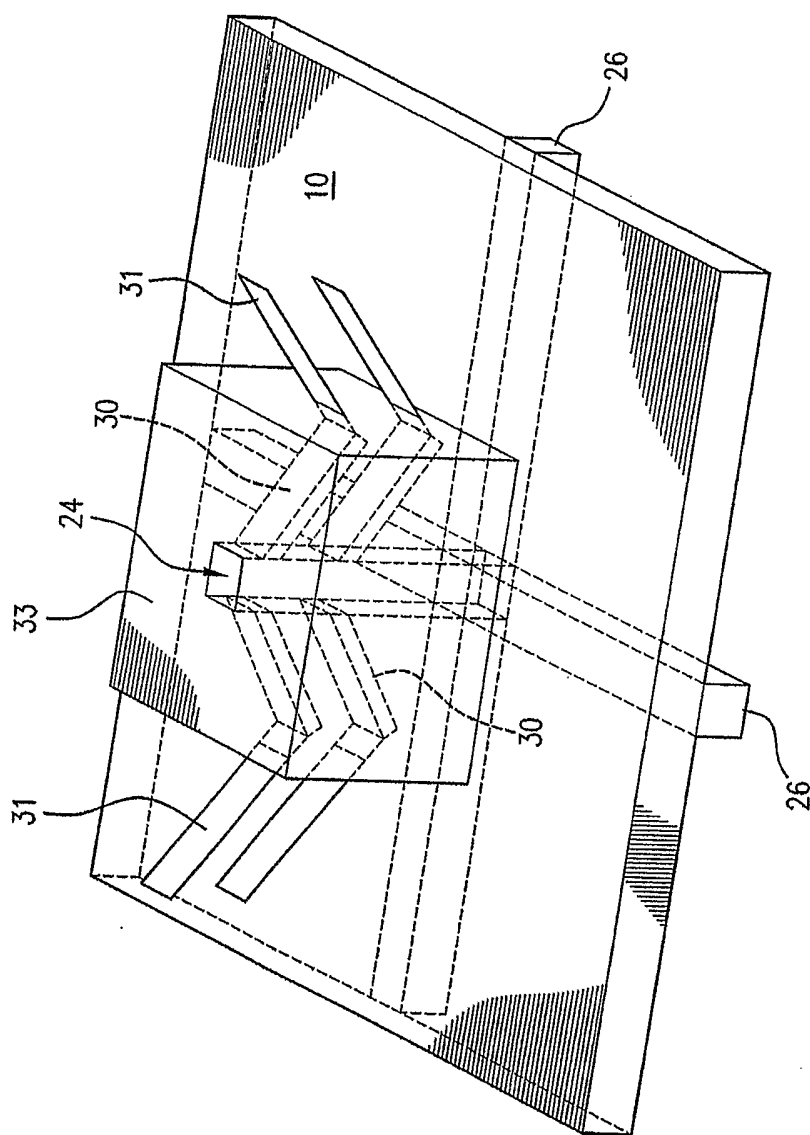

FIG. 5

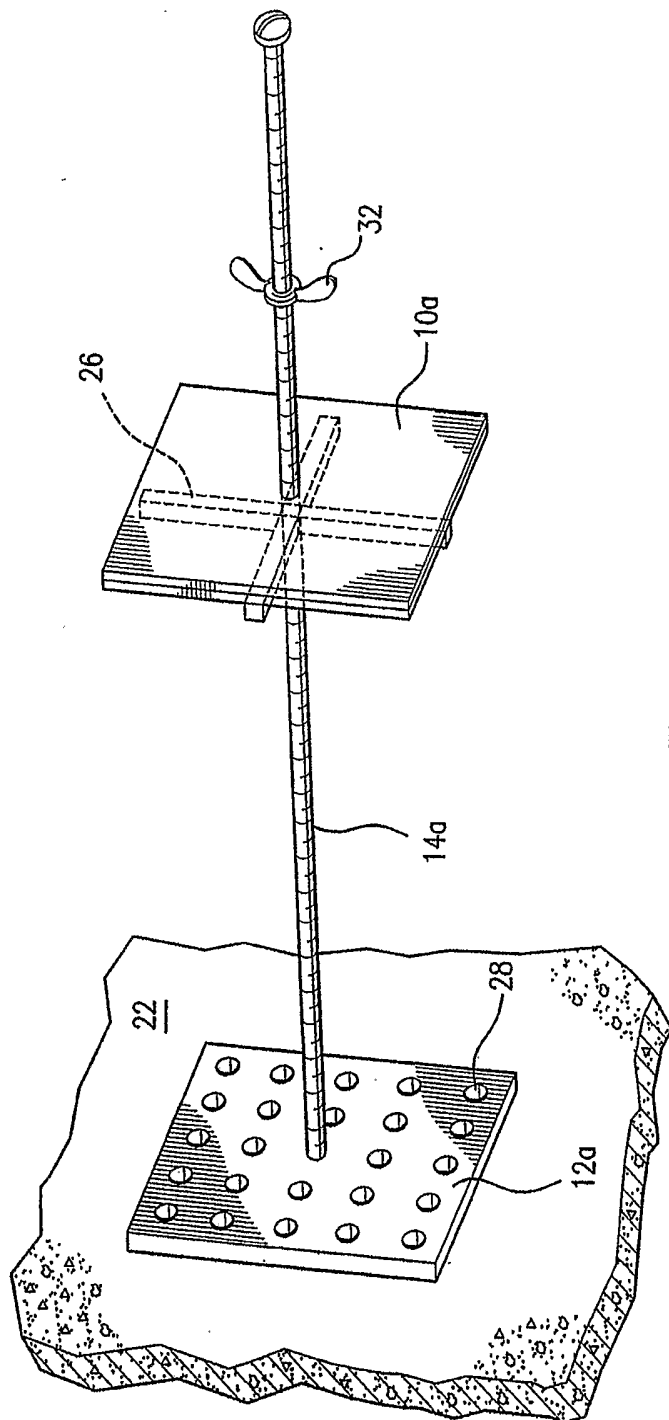

FIG.6

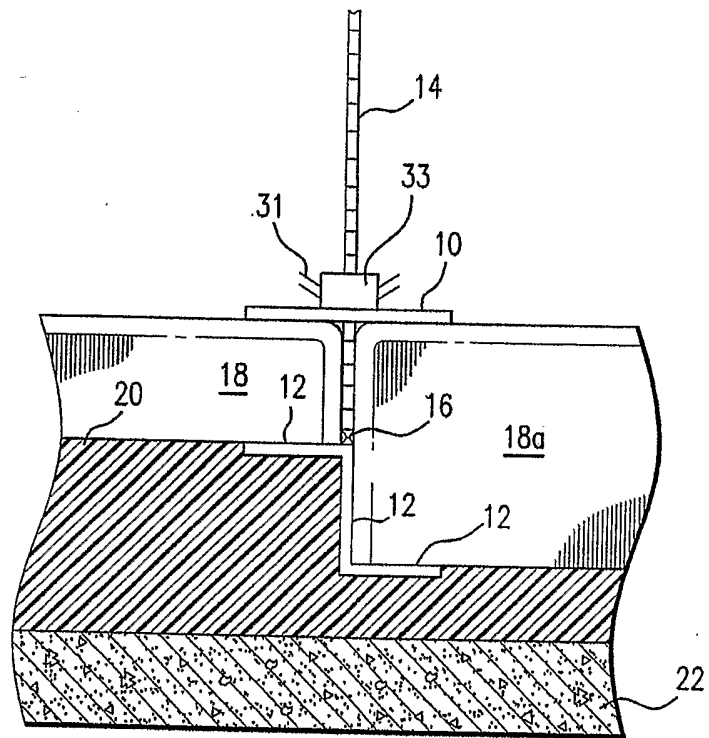

FIG. 7

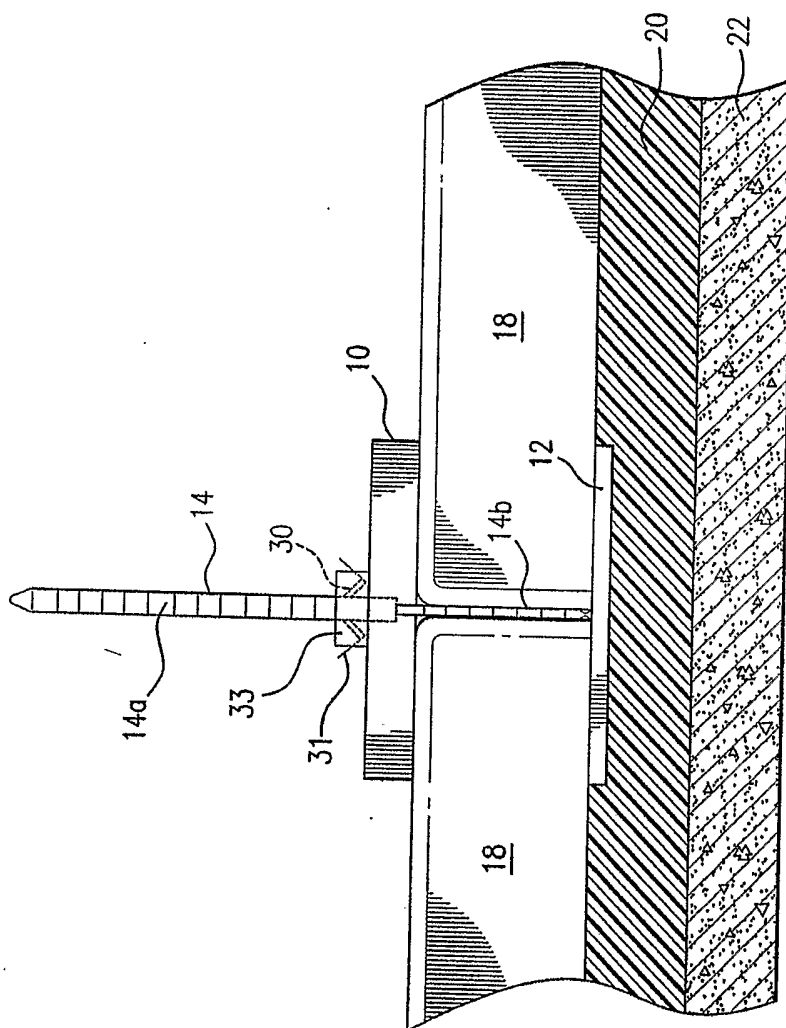

FIG.8

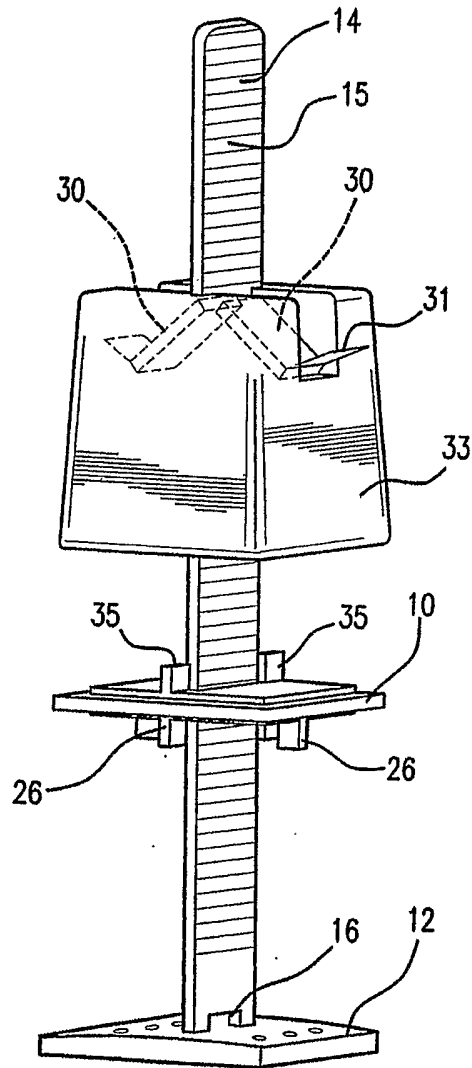

FIG. 9

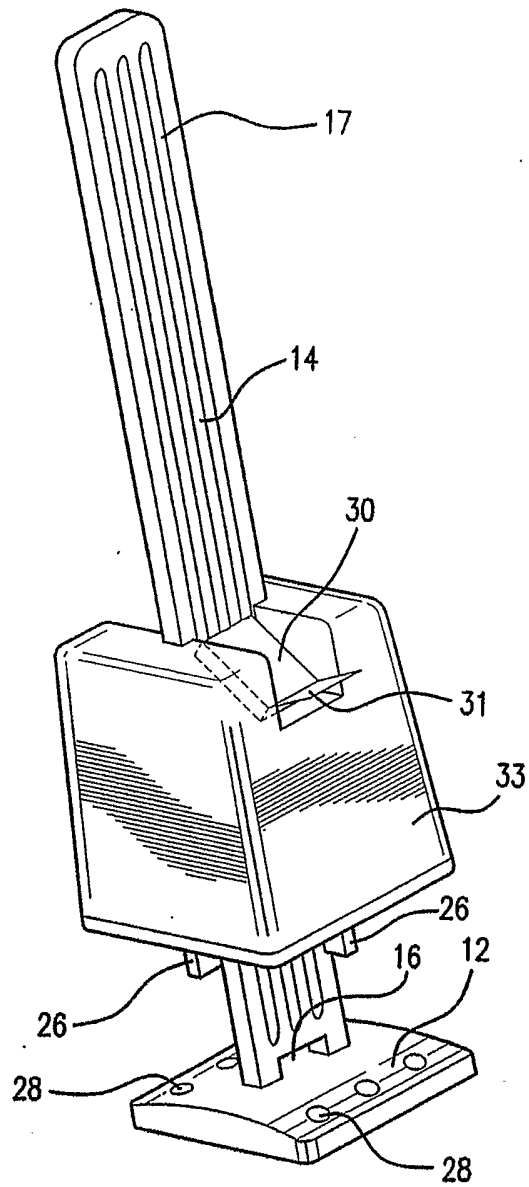

FIG. 10