

(No Model.)

2 Sheets—Sheet 1.

J. F. NOONAN.
SOLE CHANNELING MACHINE.

No. 522,799.

Patented July 10, 1894.

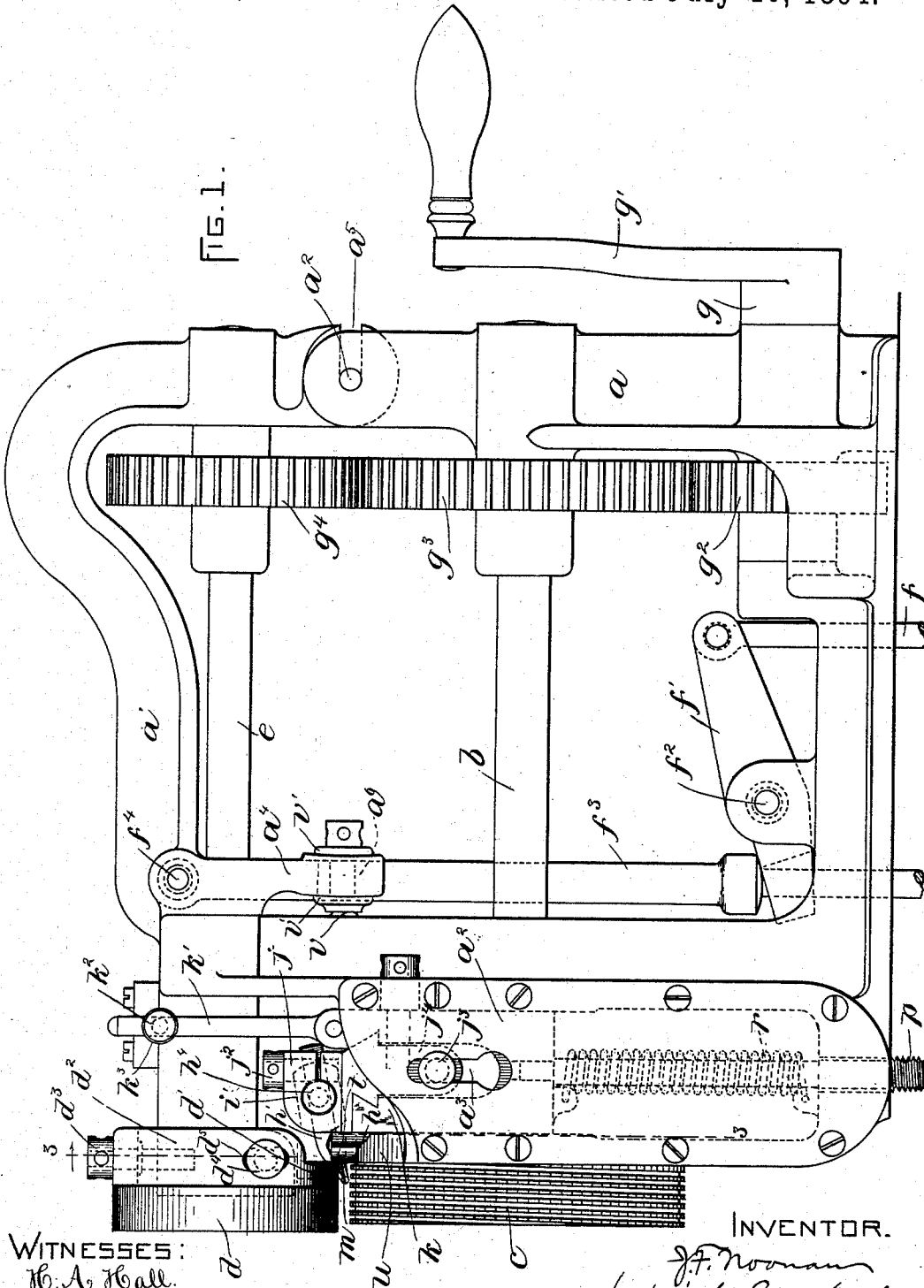

WITNESSES:
H. A. Hall.
A. D. Harrison.

INVENTOR.
J. F. Noonan
by Wright Pennell Crossley
Atty.

(No Model.)

2 Sheets—Sheet 2.

J. F. NOONAN.
SOLE CHANNELING MACHINE.

No. 522,799.

Patented July 10, 1894.

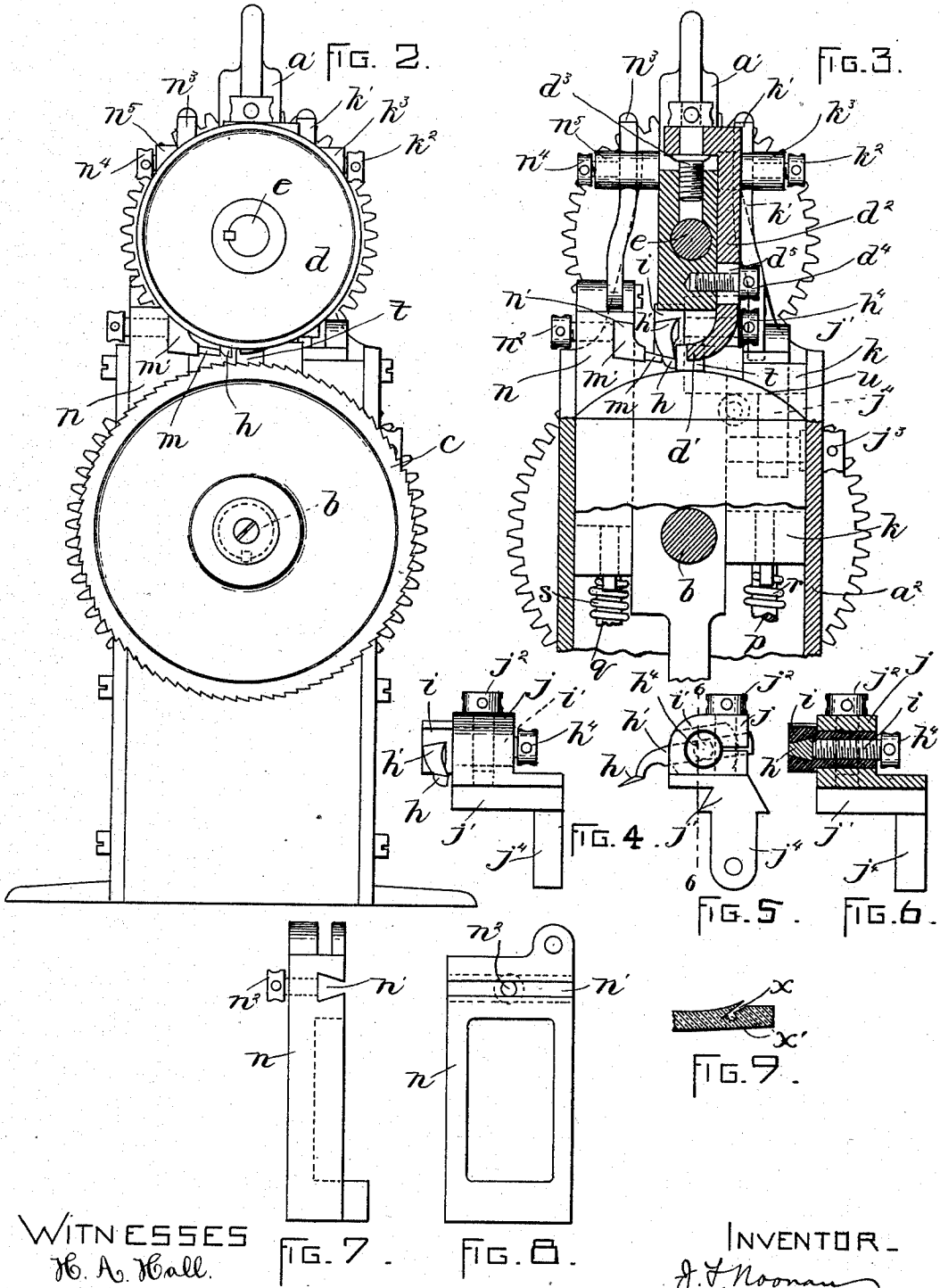

WITNESSES
H. A. Hall.
A. D. Hammons

INVENTOR
J. F. Noonan
by Wright & Brown
Atty.

UNITED STATES PATENT OFFICE.

JAMES F. NOONAN, OF LYNN, MASSACHUSETTS.

SOLE-CHANNELING MACHINE.

SPECIFICATION forming part of Letters Patent No. 522,799, dated July 10, 1894.

Application filed September 5, 1893. Serial No. 484,836. (No model.)

To all whom it may concern:

Be it known that I, JAMES F. NOONAN, of Lynn, in the county of Essex and State of Massachusetts, have invented certain new and useful Improvements in Sole-Channeling Machines, of which the following is a specification.

This invention has for its object to provide an improved machine, primarily for channeling boot and shoe soles, which can be readily adapted to perform feather edging and other operations.

The invention consists in the several improvements which I will now proceed to describe and claim.

Of the accompanying drawings, forming part of this specification: Figure 1 represents a side elevation of a channeling machine embodying my improvements. Fig. 2 represents an end elevation of the same. Fig. 3 represents a section on line 3—3 of Fig. 1, looking toward the right. Figs. 4 and 5 are elevations of the channel-cutter holder and the part that supports it. Fig. 6 represents a section on line 6—6 of Fig. 5. Figs. 7 and 8 are elevations of the slide or block that supports the groove-cutter. Fig. 9 represents a sectional view of a part of a channeled sole.

The same letters of reference indicate the same parts in all the figures.

In the drawings: a represents the fixed part of the supporting-frame, having bearings for the shaft b , which carries the work-supporting and feeding wheel c .

d represents the pressure-wheel, which is affixed to the shaft e , the latter being journaled in bearings in the movable part a' of the supporting-frame. Said movable part a' , which I hereinafter term a head, is pivotally connected at a^2 with the frame a , so that the said head can swing vertically to raise and lower the parts carried by and connected with it.

The head a' may be raised by means of a treadle (not shown), a rod f connected with said treadle, a lever f' connected at one end with said rod and pivoted at f^2 to the frame a , and a rod f^3 bearing on the other end of the lever f' and connected at f^4 with the swinging head a' .

Motion may be imparted to the shafts b e by means of a shaft g , journaled in the frame

a and having a crank g' and a gear g^2 , a gear g^3 on the shaft b meshing with the gear g^2 , and a gear g^4 on the shaft e meshing with the gear g^3 .

d' represents a presser-foot, adjustably secured to the head a' and standing beside the wheel d , said foot being arranged to bear on the upper side of the sole just in front of the point where the channel-cutter and the groove-cutter hereinafter described act on the sole. The foot d' is formed on a shank d^2 , which is vertically adjustable on the head a' .

A screw d^3 , the head of which is engaged with a flange on the shank d^2 (see Fig. 3) and the threaded portion with a threaded socket in the head a' , raises or lowers the shank or foot when rotated.

d^4 represents a clamping-screw, engaged with a threaded socket in the head a' and passing through a slot d^5 in the shank d^2 , the head of said screw being formed to bear on the said shank.

h represents the channel-cutter, the shank h' of which is of dovetail form, and is inserted in a dovetail groove formed in a block or holder i , and may be secured in said groove by a set-screw h^4 . Said holder is formed on a cylindrical stud i' , which is embraced by a split clamp j on a dovetail slide j' . The clamp is adjusted to grasp or release the stud i , by means of a screw j^2 . The slide j' is horizontally movable in a dovetail guide, formed in a slide or holder k , which is vertically movable between guides on the frame a , and is connected by a rod k' with the swinging head a' so that the cutter rises and falls with the head. The slide j' is adjustable horizontally by means of a screw j^3 , the head of which is grooved to engage the edges of a slot a^3 formed in a plate a^2 affixed to the frame a . The engagement of said head with the slot permits the screw j^3 to rotate and move up and down, but prevents it from moving endwise; so that, when the screw is rotated, the engagement of its threaded portion with a threaded socket in an ear j^4 formed on the slide causes the slide to move endwise.

The channel-cutter h is arranged to project into the space between the feed-wheel and the pressure-wheel, and is enabled by the above-described devices to be adjusted endwise, sidewise and vertically. An endwise adjust-

ment may be effected by loosening the screw h^4 and sliding the shank h of the knife in said stud, thus moving the cutter in a direction parallel with the shaft b . A sidewise adjustment may be effected by rotating the screw j^3 , and thus moving the slide j' and the cutter in a direction at right angles to the shaft b . A vertical adjustment may be effected by loosening the set-screw k^2 that secures the rod k' to a socket k^3 formed on the head a' , raising or lowering said rod and with it the block k and the channel-cutter, and then tightening said screw. The cutter may be further adjusted by turning the stud v' in the socket j , and thus swinging the cutter up or down and varying the angle of its cutting edge.

m represents the groove-cutter, which forms the groove x' (see Fig. 9) in the channel x made in a sole x^2 by the knife h . Said groove-cutter is affixed to a dovetail holder m' , which is fitted to move in a horizontal dovetail groove n' in a block or slide n , and is rigidly secured to said slide by a set-screw n^2 . The slide n is vertically movable between guides on the frame a , and is connected by a rod n^3 with the head a' , so that the groove-cutter, as well as the channel-cutter, moves vertically with the said head. The groove-cutter is made adjustable both endwise and vertically by the described devices. An endwise adjustment of said cutter, in a direction parallel with the shaft b , may be effected by moving the holder m' in the slide n ; while a vertical adjustment may be effected by loosening the set-screw n^4 that secures the rod n^3 to a socket n^5 on the head a' , and then raising or lowering said rod, the screw being subsequently tightened.

It will be seen that both the channel-cutter and the groove-cutter may be adjusted to suit a considerable variety of requirements, and that each may be adjusted independently of the other, the channel-cutter having a lateral movement toward and from the groove-cutter, in addition to the endwise and vertical movements. The slides k and n may be moved upwardly, to raise the cutters h and m , by means of screw-rods $p q$, which are engaged with threaded sockets in the base of the frame a and bear at their upper ends against said blocks, as shown in Figs. 1 and 3. When either rod is rotated to give it an upward movement, the slide against which it bears is correspondingly raised. Springs $r s$, surrounding the rods $p q$, are attached at their lower ends to the frame a , and at their upper ends respectively to the slides $k n$. Said springs exert a downward yielding pull on the slides $k n$, and through said slides and the rods $k' n^3$ on the head a' and its attachments, so that the presser-wheel d , presser-foot d' , channel-cutter h and groove-cutter m are all yieldingly held down by the springs as far as the adjustment of the rods $p q$ permits, said rods acting as stops to limit the downward movement of the described parts

by the springs, and as adjusting devices to raise the head and its attachments.

t represents a gage-roll, which rotates loosely on a stud affixed to the frame a , and projects upwardly from a curved fixed shoulder u on said frame, said shoulder and gage-roll being at the inner side of the feed-wheel. The presser-foot d' and wheel d project somewhat below the upper end of the gage-roll, as shown in Fig. 1, and may be adjusted horizontally toward and from said gage-roll, by means of an adjusting-screw v (Fig. 1), the head of which has flanges $v' v'$ engaged with an ear a^4 on the head a' , while the threaded part of said screw is engaged with a threaded socket in the frame a . A slot a^5 , receiving the pivot a^2 that connects the head a' with the frame a , permits the horizontal adjustment of the head and of the wheel d and foot d' , which may be effected by rotating the screw v . A slot a^6 in the arm a^4 permits the required vertical movement of the head a' independently of the screw v .

Operation: The sole to be channeled is inserted between the feed-wheel and presser-wheel and foot, the inner edge of the sole bearing against the gage-roll t . The wheels $c d$ are then rotated, and the sole is thus moved against the cutters h and m , until a channel of the desired length has been cut, the sole being then removed.

The machine constructed as described may be employed for feather-edging and other trimming operations, a cutter suited to the desired operation being substituted for the channel-cutter, and the groove-cutter removed, if desired.

I claim—

1. In a channeling machine, the combination of a supporting-frame having a feed-wheel, a vertically-swinging head pivotally connected with said frame and provided with a presser-foot, a block or slide substantially such as k movable on the frame, a connection between said block and the head whereby the block is caused to move with the head, a knife-carrying slide movable horizontally on said block, and means for vertically adjusting said block or slide k independently of the head, as set forth.

2. In a channeling machine, the combination of a supporting-frame having a feed-wheel, a vertically-swinging head pivotally connected with said frame and provided with a presser-foot, a block or slide substantially such as k movable on the frame, a connection between said block and the head whereby the block is caused to move with the head, a knife-carrying slide movable horizontally on said block, and a knife-holding block adjustably secured to said slide and movable at right angles to the direction of movement of the slide to adjust the knife in a direction at right angles with the axis of the feeding-wheel, as set forth.

3. In a channeling machine, the combination of a supporting-frame having a feed-

wheel, a vertically - swinging head pivotally connected with said frame and provided with a presser-foot, a block or slide substantially such as k movable on the frame, a connection
 5 between said block and the head whereby the block is caused to move with the head, a knife-carrying slide movable horizontally on said block and provided with a clamp, and a knife-
 10 holding block having a groove to hold the knife-shank and a stud rotatable in said clamp whereby the inclination or angle of the knife may be varied, as set forth.

4. In a channeling machine, the combination of a supporting-frame having a feed-
 15 wheel, a vertically swinging head pivotally connected with said frame and provided with a presser-foot, a block or slide substantially such as k movable on the frame, a connection
 20 between said block and the head whereby the block is caused to move with the head, a knife-carrying slide movable horizontally on said block and provided with a knife-holder, an adjusting-screw engaged with the supporting-
 25 frame and with the block or slide k and adapted to move said block or slide and the head up-

wardly, and a spring which normally exerts a downward pressure on said block or slide and head, as set forth.

5. In a channeling machine, the combination of a supporting-frame having a feed- 30
 wheel, a vertically - swinging head on said frame having a presser-foot, a block or slide
 35 n , adjustably connected with said head and provided with a horizontally-adjustable cutter-holder having a groove-cutter, a block or
 40 slide k adjustably connected with the head, a cutter-carrying slide movable horizontally on the block k and provided with a channel-cutter holder, and means for adjusting said slide to move the channel-cutter toward and from

In testimony whereof I have signed my name to this specification, in the presence of two subscribing witnesses, this 29th day of August, A. D. 1893.

JAMES F. NOONAN.

Witnesses:

C. F. BROWN,
 A. D. HARRISON.