

D. GOFF.

SMOKE AND GAS RETURNING APPARATUS FOR FURNACES.

(Application filed May 13, 1897. Renewed July 13, 1898.)

(No Model.)

5 Sheets—Sheet 1.

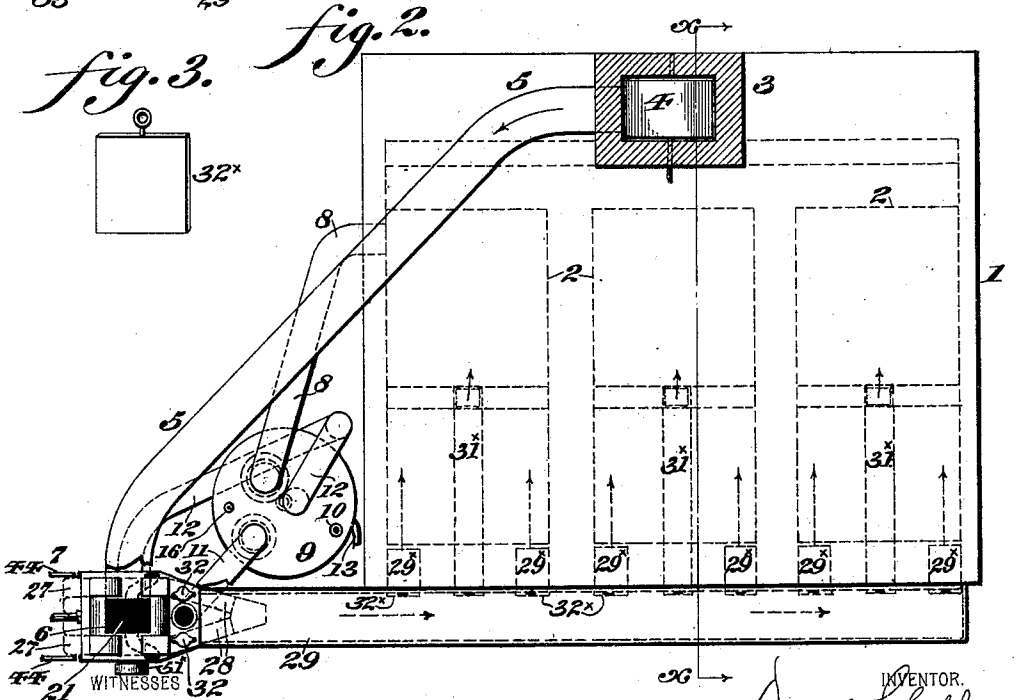
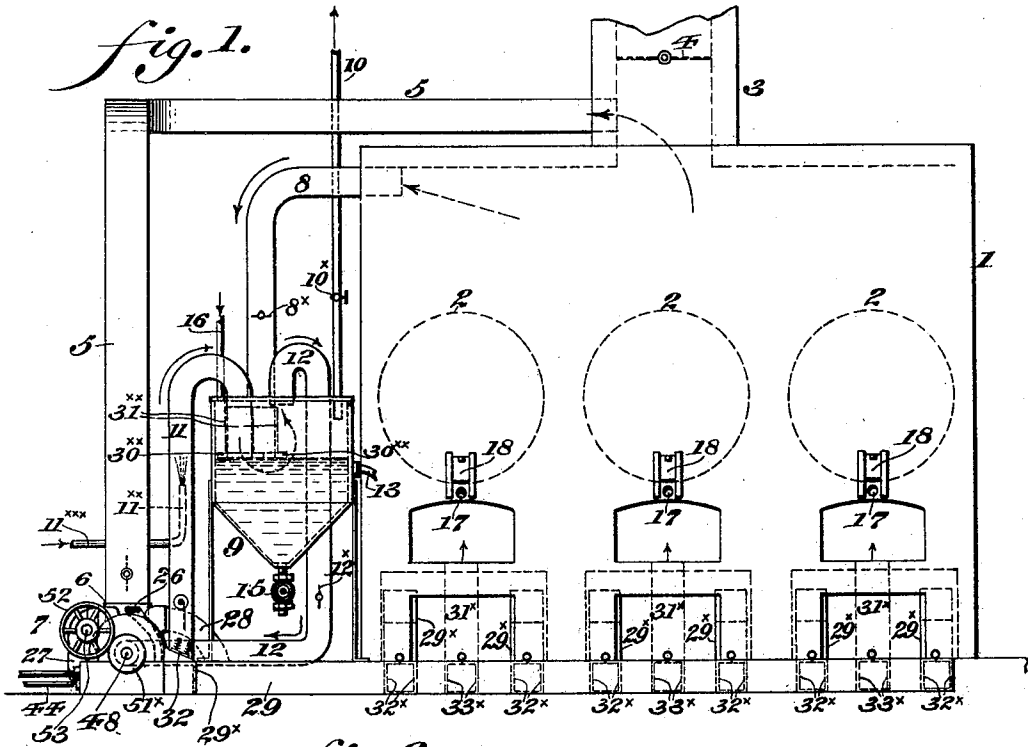

WITNESSES
 L. Douville,
 C. T. Angle.

INVENTOR.
 Daniel Goff.
 BY
 Wiederheim & Fairbanks
 ATTORNEYS

No. 618,863.

Patented Feb. 7, 1899.

D. GOFF.

SMOKE AND GAS RETURNING APPARATUS FOR FURNACES.

(Application filed May 13, 1897. Renewed July 13, 1898.)

(No Model.)

5 Sheets—Sheet 2.

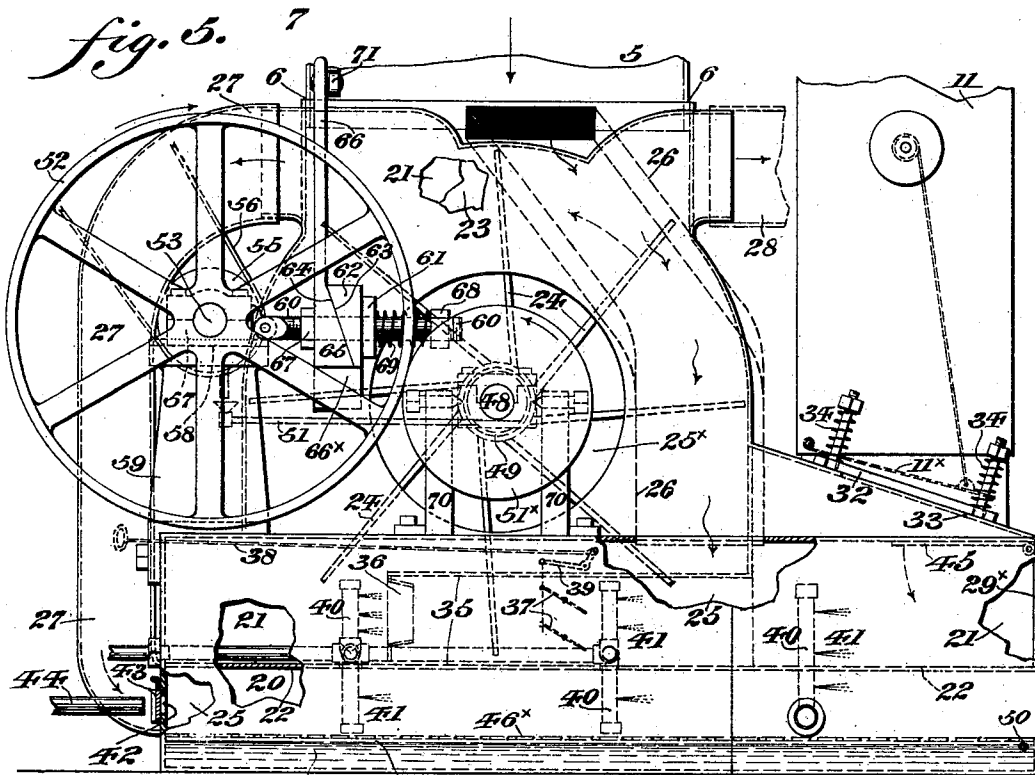
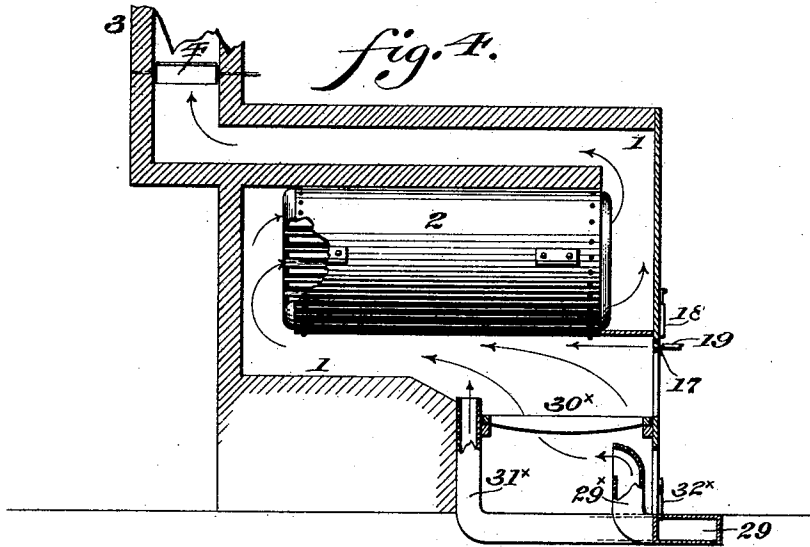

WITNESSES

L. Downille,
P. H. Bagley.

INVENTOR.

Daniel Goff.
BY
Wiederheim & Fairbanks
ATTORNEYS

D. GOFF.

SMOKE AND GAS RETURNING APPARATUS FOR FURNACES.

(Application filed May 13, 1897. Renewed July 13, 1898.)

(No Model.)

5 Sheets—Sheet 3.

fig. 6.

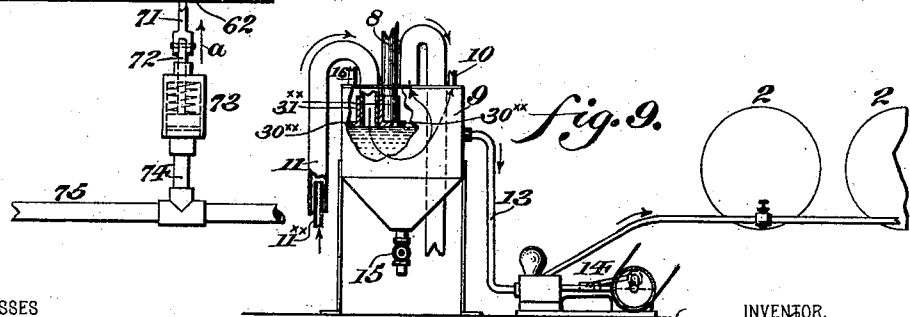
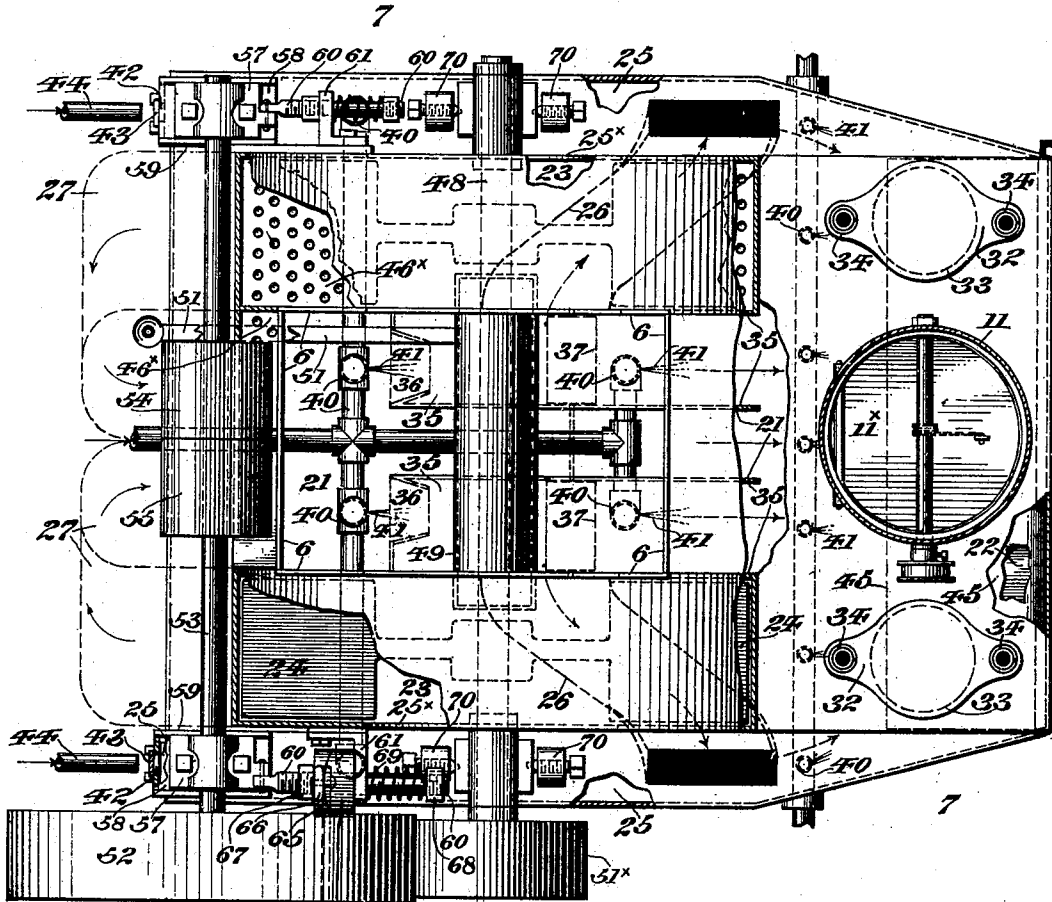

WITNESSES

L. Bouville,
P. F. Anger.

INVENTOR.

Samuel Goff.
BY
Wiederheim & Fairbanks
ATTORNEYS

No. 618,863.

Patented Feb. 7, 1899.

D. GOFF.

SMOKE AND GAS RETURNING APPARATUS FOR FURNACES.

(Application filed May 13, 1897. Renewed July 13, 1898.)

(No Model.)

5 Sheets—Sheet 5.

fig. 11.

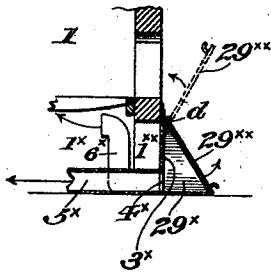
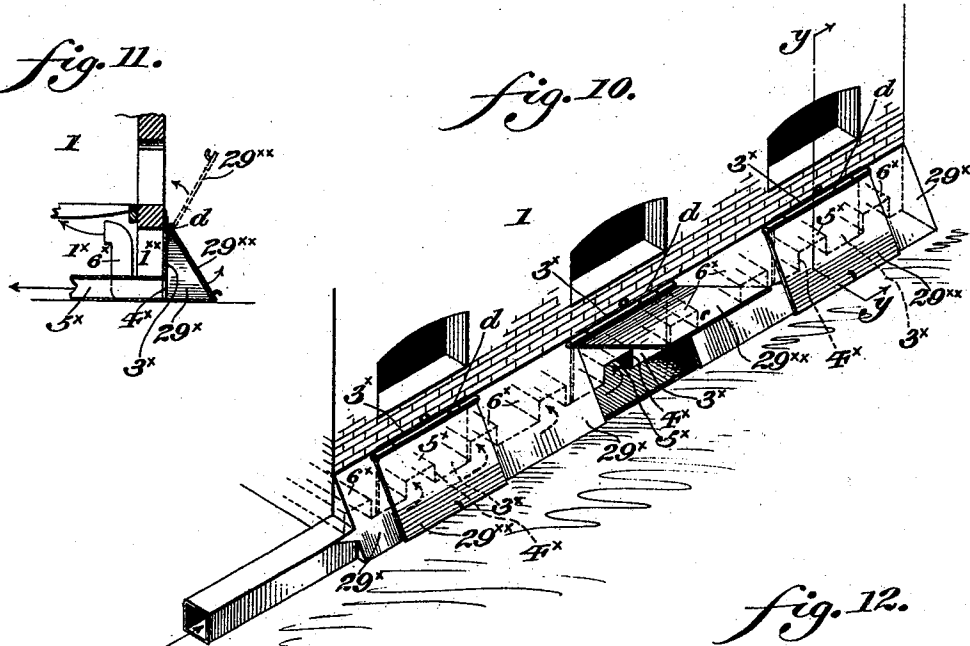
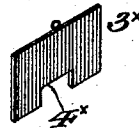

fig. 10.



PRODUCTS OF COMBUSTION
FROM APPARATUS 7.

fig. 12.



WITNESSES:

L. Douville.

P. H. Bagley.

INVENTOR

Daniel Goff.

BY

Wiedersheim & Fairbanks

ATTORNEYS

UNITED STATES PATENT OFFICE.

DANIEL GOFF, OF MILLVILLE, NEW JERSEY.

SMOKE AND GAS RETURNING APPARATUS FOR FURNACES.

SPECIFICATION forming part of Letters Patent No. 618,863, dated February 7, 1899.

Application filed May 13, 1897. Renewed July 13, 1898. Serial No. 685,878. (No model.)

To all whom it may concern:

Be it known that I, DANIEL GOFF, a citizen of the United States, residing at Millville, in the county of Cumberland, State of New Jersey, have invented a new and useful Improvement in Smoke-Preventing and Gas-Returning Apparatus, for Furnaces &c., which improvement is fully set forth in the following specification and accompanying drawings.

My invention consists of a novel construction of smoke-preventing and gas-returning apparatus for furnaces, &c., in which means are provided for cooling such portions of the same as are exposed to the greatest heat.

It further consists of means for automatically regulating the speed of the blower and of devices for conducting pure air into the furnace for the support of combustion therein or commingling air and smoke, if desired, prior to their return to the furnace, provision being further made for directing said commingled smoke and air to other points, if desired.

It further consists of novel details of construction, all as will be hereinafter fully set forth, and pointed out in the claims.

Figure 1 represents a side elevation of a smoke and gas returning apparatus embodying my invention and a portion of a furnace to which the same is applicable. Fig. 2 represents a partial plan view and partial horizontal section of the parts shown in Fig. 1. Fig. 3 represents a perspective view of a valve or damper employed on an enlarged scale.

Fig. 4 represents a transverse vertical section of the furnace, the section being taken on line *xx*, Fig. 2. Fig. 5 represents a side elevation, partly broken away, of the smoke and gas returning apparatus on an enlarged scale. Fig. 6 represents a partial plan view and partial horizontal section of the apparatus. Fig. 7 represents an end elevation, partly broken away, of the apparatus. Fig. 8 represents an end elevation, partly broken away, of the gas and smoke returning apparatus, showing the opposite end to that shown in Fig. 7. Fig. 9 represents a partial side elevation and partial vertical section of certain detached portions of the device on a reduced scale. Fig. 10

represents a perspective view of a modified form of flue which may be employed in con-

nection with my invention. Fig. 11 represents a vertical section on line *yy*, Fig. 10. Fig. 12 represents a perspective view of a plate employed in connection with the above-mentioned features of my invention.

Similar numerals of reference indicate corresponding parts in the figures.

Referring to the drawings, 1 designates a furnace with steam-boilers 2 located therein.

3 designates the smoke-stack of the furnace, said smoke-stack having therein a damper 4, which when opened permits the products of combustion in the furnace 1 to escape into the open air and when closed prevents the escape of said products of combustion.

5 designates a flue which leads from the smoke-stack 3 to the opening 6 in the gas and smoke returning apparatus 7, the object of said flue being to convey the products of combustion from the furnace 1 to the apparatus 7.

8 designates a flue leading from the furnace 1 to a tank or feed-water heater 9, so as to convey a portion of the products of combustion from the furnace 1 to said tank or heater, for a purpose to be hereinafter described.

10 designates a pipe connected to the tank or feed-water heater 9 and leading therefrom to the open air, so as to allow the gases in said tank or feed-water heater to escape there-through, and thus reach the atmosphere.

11 designates a pipe which leads from the apparatus 7 to the tank or feed-water heater 9, so as to convey a portion of the products of combustion from said apparatus to the tank or feed-water heater 9, for a purpose to be hereinafter described.

The pipe 11 is provided with a damper 11^x for opening and closing the communication between a chamber 21 in said apparatus and the tank 9. (See Fig. 5.)

12 designates a pipe which leads from the tank or feed-water heater 9 to the apparatus 7, so as to convey the gases contained in said tank or heater to said apparatus in order that the latter may, by means hereinafter described, force said gases into the furnace 1 for the purpose of combustion.

The tank or feed-water heater 9 has connected to it a pipe 13, and the latter is connected to a pump 14, which draws the water

from the tank 9 and forces it into the boilers 2. (See Fig. 9.)

The lower portion of the tank 9 is of conical or similar shape, so as to direct the sediment, &c., which may be contained in the water in said tank to the valve or spigot 15, which latter when opened permits the sediment, &c., to be withdrawn from said tank, the latter being provided with a pipe 16, which supplies the same with water.

In the front walls of the furnace 1 are openings 17, as best seen in Figs. 1 and 4, which are provided with gates 18 for closing the same to prevent the products of combustion from escaping therethrough. The object of the openings 17 is to permit a jet of steam to be forced through them and into the interior of the furnace, said jet carrying with it a supply of fresh air, so as to assist the combustion within the same.

19 designates a pipe which is in alinement with one of the openings 17, as seen in Fig. 4, and directs a jet of steam through the same and into the furnace 1.

The apparatus 7 consists of the two compartments 20 and 21, (see more particularly Figs. 5, 7, and 8,) it being noted that the said compartments are separated by a partition 22.

23 designates the chambers in which are located the fans 24.

Leading from the upper portion of the chambers 21 are flues 26, which connect with chambers 25 and direct a portion of the products of combustion from said chamber 21 to the chambers 25. The flues 26 are shown in dotted lines in Figs. 1, 2, and 5 for the sake of clearness of illustration.

Leading from the upper portions of the fan-chambers 23 are flues 27, which connect with the chamber 20 and direct a portion of the products of combustion and air in said chambers 23 to the chamber 20.

Leading from the upper portions of the fan-chambers 23 are flues 28, which connect with a flue 29 and direct a portion of the products of combustion in said chambers 23 to the flue 29.

The chamber 21 is provided with safety-valves 32, which are seated in the openings 33 in said chamber 21 and retained in their normal positions by springs 34. The object of said valves 32 is to permit the gases, &c., to escape through the openings 33 should an explosion occur within the apparatus 7.

Within the chamber 21 are chambers 35, which communicate with said chamber 21 through the ports 36, the object of said chamber being hereinafter described.

The chambers 21 and 35 are provided with dampers 37, which when open permit the products of combustion to pass from the upper portion of the chamber 21 to the flue 29, and when closed prevent the products of combustion in the furnace from returning through said flue 29 to a point beyond the dampers 37. The dampers 37 may be operated by a

rod 38 and bell-crank lever 39, as shown in Fig. 5, said dampers 37 not being shown in the chamber 21 for clearness of illustration of said chamber.

Located within the chambers 21, 25, and 35 are steam-pipes 40, provided with perforations through which the steam in said pipes escapes in the form of jets, as at 41, thereby producing a current which carries with it the products of combustion in said chambers 21, 25, and 35 and directs them to the furnace 1.

Each chamber 25 is provided with an opening 42, which may be closed when desired by a valve 43, and registering with each of said openings 42 is a steam-pipe 44, which when desired discharges a jet of steam into said chambers 25 so as to assist in forcing the products of combustion therein to the furnace 1 and also to reduce the temperature of the products of combustion in the chambers 25, so as to prevent the latter from becoming overheated. The jet of steam from the pipes 44 will also force pure air into the chambers 25, so as to commingle the same with the products of combustion therein.

The chamber 21 is provided with a damper 45, which when open permits the products of combustion in said chambers 21 and 25 to pass into the flue 29 and reach the furnace 1, and when partly closed permits the escape at this point of only a certain portion of the products of combustion in said chambers 21 and 25, the other portion passing through the pipe 11 to the tank 9, it being evident that the chambers 25 lead into the chamber 21.

In the lower portions of the chambers 20 and 23 are troughs 46, which contain water or other cooling medium 47, the function of which is to prevent the products of combustion within the apparatus 7 from overheating the same. The liquid in each trough 46 is covered by a perforated plate 46^x, which prevents said liquid from being dislodged by the action of the fans 24. The perforations in the plates 46^x permit the vapor from the liquid 47 to escape therethrough and reach the portions of the apparatus above the same.

The shaft 48 of the fans 24 is protected from the heat of the products of combustion by a cylinder 49 partly filled with the cooling medium 47. Both ends of the cylinder 49 are partly open to permit the cooling medium in said cylinder to escape at these points and drop into the troughs 46, from which latter said cooling medium may be withdrawn by a discharge-pipe 50, as seen in the lower right-hand portion of Fig. 5. The water or other cooling medium 47 may be fed to the cylinder 49 by a pipe 51, which can be supplied from any suitable source.

Keyed or otherwise secured to the shaft 48 is a friction-pulley 51^x, which is normally in contact with a friction-pulley 52 on the driving-shaft 53 of the apparatus 7. The shaft 53 carries a fixed and a loose pulley 54 and 55, respectively, the driving-belt 56 passing

around the former when the apparatus is in operation and around the latter when the same is inoperative.

The shaft 53 is journaled in sliding boxes 57, which are guided in ways 58 in the standards 59, so that said boxes 57, and consequently the shaft 53 and friction-pulley 52 thereon, may be moved in a direction at a right angle to the axis of the shaft 53 for a purpose to be hereinafter described.

The journal-boxes 57 are pivotally connected to rods 60, which pass freely through openings in the brackets 61, so that said rods 60 may be moved in the direction of their length, so as to cause the pulley 52 at certain times to bear firmly against the pulley 51 and at others to loosely contact with the same for a purpose to be hereinafter explained.

The bracket 61, adjacent to the friction-pulley 52, has secured to it a collar 62, (see more particularly Fig. 5,) whose inclined face 63 contacts with the inclined face 64 of the hub 65 of an arm or lever 66, loosely mounted on the rod 60. The hub 65 contacts with a nut 67 on the rod 60, so that when a rotary motion is imparted in a certain direction to the arm 66 the latter will, owing to the inclined face 64 of its hub 65 and the inclined face 63 of the collar 62, cause the nut 67, the rod 60, the journal-box 57, the shaft 53, and pulley 52 thereon to move away from the pulley 51, so as to reduce the friction of the contacting surfaces of said pulleys 51 and 52 for a purpose to be hereinafter described.

The rod 60 is provided with a nut 68, against which abuts one end of a spring 69, which encircles the rod 60 and whose opposite end abuts against the bracket 61, the object of said nut and spring being to cause the nut 67 to at all times bear against the hub 65, so as to cause its inclined face 64 to remain in contact with the inclined face 63 of the collar 62 and also restore the shaft 53, and consequently the pulley 52 thereon, to their original positions when the arm or lever 66 is returned to its normal position, and thereby cause the pulley 52 to bear firmly against the pulley 51.

The shaft 48, on which are mounted the fans 24, is journaled in standards 70, which rise from the lower portion of the casing of the apparatus 7.

In order to automatically regulate the amount of friction between the pulleys 51 and 52, the arm or lever 66 is pivotally connected to one end of a rod 71, (seen in Fig. 6,) the other end thereof being connected to the stem 72 of the friction-regulating device 73, which latter is connected by a branch pipe 74 to the steam-main 75, so that any variation of steam-pressure in the boilers 2 will act upon said device 73 in a manner hereinafter described and cause the pulley 52 to drive the pulley 51, and consequently the fans 24, faster or slower, according to the condition of the fire in the furnace 1.

The flue 29 is provided with branches 29^x,

(see Figs. 1, 2, and 4,) which discharge the products of combustion at a point below the grate 30^x, so that said products of combustion may be consumed while passing upwardly between the bars of the grate 30^x in the furnace. The flue 29 is also provided with branches 31^x, which discharge the products of combustion fed to them from said flue 29 at a point above and in the rear of the grate 30^x, so that said products of combustion may be consumed at a point above said grate 30^x. The object in thus locating the branches 29^x and 31^x is to distribute the products of combustion discharged from the same over a larger area in order to facilitate the combustion in the furnace 1. The branches 29^x and 31^x are each provided with a damper 32^x and 33^x, respectively, so that any one of said branches may be shut off from the flue 29 when so required.

The portions of the flues 8 and 11 which are within the tank 9 have each loosely fitted thereon a sleeve 31^{xx}, which latter is secured to a float 30^{xx}, which rests on the water within the tank 9 and rises and falls with the varying levels of the same.

The object of the sleeves 31^{xx} and float 30^{xx} are for the purpose of forming a close connection between the flues 8 and the water in the tank 9 and also between the flue 11 and said water, so that the products of combustion fed to the tank by said flues 8 and 11 will be compelled to pass through the water in said tank so as to be converted into a gas before the same can escape therefrom through either the flue 12 or pipe 10.

The modification shown in Figs. 10 and 11 illustrates a flue 29^x, whose object is the same as that described in connection with the flue 29, the former of these, however, being triangular in cross-section instead of rectangular, as is the flue 29, thereby permitting said flue 29^x to be provided with doors 29^{xx}, which may be hinged, as at *d*, to the flue 29^x, so that said doors may be opened in order to gain access to the ash-pit 1^x of the furnace 1, (see Figs. 10 and 11,) whereby I avoid the necessity of digging up the floor of a boiler-room for the insertion of the flue which conveys the products of combustion from the apparatus 7 to the furnace 1. The openings 1^{xx}, which lead into the furnace 1 from the flue 29^x, are each normally closed by a sliding plate 3^x, formed with an opening 4^x, which registers with the inlet of the flues 5^x, which latter correspond with the flues 31^x seen in Figs. 1, 2, and 4. The plates 3^x when in their normal or closed positions prevent the products of combustion in the flue 29^x from passing therefrom directly into the ash-pit 1^x and compel the same to pass through the branch flues 5^x before reaching the fire in the furnace 1.

When it is desired to gain access to the ash-pits 1^x, the sliding plates 3^x are raised, so as to remove the same from the openings 1^{xx}, which lead thereto from the flue 29^x, and

thereby leave said openings clear of obstruction.

The flues 6^x shown in Figs. 10 and 11 correspond to the flues 29^x seen in Figs. 1, 2, and 4, and the flues 5^x and 6^x are provided with dampers of any well-known form.

The operation is as follows: The friction-regulating device 73 is adjusted to a predetermined steam-pressure, and as long as this pressure remains the same the pulley 52 will bear firmly against the pulley 51. When a fire is started in the furnace 1, the damper 4 in the stack 3 is opened, so as to initially permit the products of combustion in said furnace to escape through the stack 3 and discharge into the open air, and when the fire in the furnace 1 is well under way and is burning freely the damper 4 is then closed to prevent the products of combustion in said furnace from escaping through said stack. The driving-belt 56 is then shifted from the loose pulley 55 to the fixed one 54, thereby imparting a rotary motion to the fans 24. The fans in rotating will produce a suction in the flue 5, and thus cause the products of combustion in the furnace 1 to enter the same and be drawn into the chamber 21 of the apparatus 7. A portion of the products of combustion in the furnace 1 may enter the flue 8, but cannot escape therefrom as the damper 8^x in said flue is closed. The products of combustion in the chamber 21 will be drawn into the fan-chambers 23 through the openings 23^x (see Fig. 7) by the rotation of the fans 24, and a portion of said products of combustion in the chambers 23 will be driven therefrom by said fans and forced into the flue 28, which leads from each fan-chamber 23 and connects with the flue 29, it being evident that the products of combustion in said flues 28 will likewise be forced into the flue 29 and be fed to the furnace 1 through the branches 29^x and 31^x, it being understood that the dampers 32^x and 33^x are open to permit the products of combustion in the flue 29 to pass therefrom and into said branches 29^x and 31^x. The rotation of the fans 24 will draw air into the fan-chambers 23 through the openings 25^x (see Figs. 5 and 6) and will discharge a portion of the same, combined with the products of combustion, through the flues 27 into the chamber 20 and force the same therefrom and into the flue 29, so as to cause the air and the products of combustion to commingle before being fed to the furnace 1. The remaining portion of the air and products of combustion in the fan-chambers 23 is driven by the fan 24 therein and caused to enter the flue 29 through the flue 28. When the products of combustion in the chamber 21 are too dense to be easily removed therefrom by the fans 24, the steam-jets in the chambers 25 are turned on, so as to produce a draft within said chambers and thereby produce a suction in the flues 26 and cause a portion of the air and products of combustion in the chamber 21 to pass down through said flues 26 and into the chamber 25

and from the latter to the flue 29 and finally to the furnace 1. When the quantity of air drawn into the apparatus by the fans 24 proves insufficient to produce free combustion in the furnace 1, a jet of steam from each pipe 44 is forced through the openings 42 (see Figs. 5 and 6) and carries with it a certain quantity of air and injects the same into said chambers 25 and causes it to commingle with the products of combustion therein before the latter is fed to the furnace 1, the jets of steam also reducing the temperature of the products of combustion within the apparatus, so as to prevent the latter from becoming overheated. When the steam-jets from the pipes 44 are not in use, the valves 43 are closed to prevent the escape of the products of combustion through the openings 42. When the steam-jets in the chambers 35 are not in use, the dampers 37 are closed, so as to prevent the return of the products of combustion through said chambers 35 into the chamber 21. The jets of steam in the chambers 35 serve also to reduce the temperature of the products of combustion in the apparatus, so as to prevent the latter from becoming overheated. When it is desired to convert a portion of the products of combustion from the furnace 1 into a gas to be used as a fuel in said furnace, the damper 45 is partly closed, so as to prevent a portion of the products of combustion in the apparatus 7 from reaching the flue 29 through the part 29^x (see Fig. 5) of the chamber 21. The damper 11^x is then opened, so as to permit a portion of the products of combustion in the apparatus 7 to be driven or forced by the mechanism hereinbefore described into the flue 11, as well as into the flue 29. The products of combustion forced through the flue 11 are directed by the same into the tank 9, where said products of combustion are compelled to pass through the water in said tank before they reach the upper portion thereof. The products of combustion when passing through the water in the tank 9 are converted into a gas, which is drawn from said tank through the flue 12 by the action of one of the fans 24, it being noted that said flue 12 leads from the tank 9 to one of the openings 25^x in the casing of the fan-chamber 23. (See Figs. 1 and 2.) The gas from the tank 9 which enters the fan-chamber 23 commingles with the products of combustion therein and is forced by the fan 24 in said chamber in two directions, one of these being through the flue 28, so as to be directed by the same into the flue 29, and the other direction being through one of the flues 27 to and through the chamber 20 to the flue 29, and finally to the furnace 1. When the products of combustion from the furnace 1 are to be discharged into the atmosphere, the valve 12^x in the flue 12 is closed, so as to prevent the gas in the tank 9 from reaching the fans 24 through said flue 12. The valves 8^x and 10^x in the flue 8 and pipe 10, respectively, are

then opened, so as to permit the products of combustion to pass from the furnace 1 into and through the flue 8 and thus enter the tank 9, where the same pass through the water in said tank and are converted into a gas, which escapes from said tank into the atmosphere through the pipe 10. The products of combustion fed to the tank by the apparatus 7 will also escape into the atmosphere through the pipe 10, said products of combustion having been, as hereinbefore stated, converted into a gas when passing through the water in said tank 9. When the pressure of steam in the boilers 2 is in excess of the predetermined amount, the same will cause the piston in the friction-regulating device 73 to advance and carry with it the stem 72, which will cause the rod 71 to move in the direction indicated by the arrow *a* in Fig. 6. This will throw the arm or lever 66 out of its normal position by rotating it on the rod 60 as an axis. The inclined faces 63 and 64 will then cause the hub 65 to move away from the collar 62, and as said hub bears against the nut 67, which is fitted on the rod 60, it will, as is evident, cause said rod, and consequently the boxes 57, shaft 53, and friction-pulley 52, to move in the same direction, thereby reducing the friction between the pulleys 52 and 51, and thus reduce the speed of the fans 24 and consequently diminish the draft in the furnace 1. The reduction in the draft in the furnace will produce a corresponding decrease of steam-pressure in the boilers, and when the desired pressure of steam is restored the lever 66 may be returned to its normal position by a weight 66^x, which depends from the hub 65. The water in the tank 9 becomes heated, due to the products of combustion passing therethrough, and said water in its heated condition may, if desired, be forced into the boilers 2 by the pump 14. In the preferred embodiment of my invention I locate within the pipe 11 a portion 11^{xx} of a steam-pipe 11^{xxx}, the object of the latter being to inject steam into said pipe 11, so as to assist the apparatus 7 in forcing the products of combustion from the same into the tank 9. The steam fed through the pipe 11^{xxx} may be obtained from any desired source.

Having thus described my invention, what I claim as new, and desire to secure by Letters Patent, is—

1. In a smoke-preventing and gas-returning apparatus, a furnace, a tank for containing water, a conduit leading from said furnace directly to said tank, a blower, a conduit separate and distinct from the first-mentioned conduit leading from the furnace to said blower, a conduit leading from the blower to the tank, and means for conveying gas from said tank.

2. In a smoke-preventing and gas-returning apparatus, a furnace, a tank for containing water, a conduit leading from said furnace directly to said tank, a blower, a conduit

separate and distinct from the first-mentioned conduit leading from said furnace to said blower, a conduit leading from said blower to said tank, and means for conveying gas from said tank to the combustion-chamber of said furnace.

3. In a smoke-preventing and gas-returning apparatus, a furnace, a tank for containing water, a conduit leading from said furnace directly to said tank, a blower, a conduit separate and distinct from the first-mentioned conduit leading from said furnace to said blower, a conduit leading from said blower to the furnace, a conduit leading from said blower to said tank, means governing the conduits leading from the blower for controlling the passage of the products of combustion therethrough, and means for conveying gas from said tank.

4. In a smoke-preventing and gas-returning apparatus, a conduit leading from a furnace-stack, an angular-shaped conduit to the combustion-chamber and ash-pit respectively, the doors 29^x arranged in proximity to the ash-pits, and a recessed plate or valve 3^x adapted to be supported adjacent to the furnace.

5. In a smoke-preventing and gas-returning apparatus, a shaft having a fan mounted thereon, a pulley mounted on said shaft and adapted to contact with an adjacent pulley, a shaft on which the latter is mounted, boxes in which said last-mentioned shaft is supported, means for rotating said last-mentioned shaft, a connection from one of said boxes to a suitable support, a nut mounted on said connection having a collar 65, bearing against the same and rotatably supported, said collar having an inclined face bearing against an adjacent collar, a spring intermediate said last-mentioned collar and an adjacent fixed point, an arm attached to one of said collars, a rod pivotally secured thereto, a cylinder having a piston therein in communication with a steam-main, a spring interposed between a side of said piston and a wall of said cylinder, and a connection from said piston to said rod.

6. In a smoke-preventing and gas-returning apparatus, a furnace having an outlet leading from the stack thereof to a water-holding tank 9, and another outlet separate and distinct from the first-mentioned outlet leading to a blowing apparatus 7 constructed substantially as shown, connections common to said blowing apparatus and tank, and a conduit leading from said blowing apparatus to the boiler-furnace.

7. In a smoke-preventing and gas-returning apparatus, a water-holding tank, having inlet and outlet pipes communicating with the upper portion thereof, certain of said inlet-pipes leading from the stack of the boiler, adjustable sleeves mounted on the ends of said pipes within said tank, and floats for said sleeves in combination with means for forcing the products of combustion through

said tank from said furnace, and means for feeding the heated water in said tank to a boiler.

5 8. In a smoke-preventing and gas-returning apparatus, a tank 9 adapted to receive water, a connection from the smoke-stack of a furnace leading to said tank, a blowing apparatus, a connection from the latter to said stack, a connection from said blowing apparatus to said tank, a connection from the latter leading to said blowing apparatus, means for supplying steam to the latter, and means for conducting the commingled products of combustion and steam to a furnace.

15 9. In a smoke-preventing and gas-returning apparatus, a blowing apparatus having therein the chambers 20 and 21, a trough for the reception of water in the lower portion of said apparatus provided with a perforated plate extending over the surface of said water, the chambers 25 located in a side of said blowing apparatus, steam-pipes communicating with said chambers and means for conducting products of combustion to a furnace.

25 10. In a smoke-preventing and gas-returning apparatus, a blowing apparatus consisting of an intermediate chamber 21, the fan-chambers 23 located on either side thereof, a passage 5, leading to said chamber 21 from the stack of a boiler, side chambers 25 in communication with the passage 5 by means of the flues 26, the chambers 35 having the contracted inlets 36, steam-jets located in said chambers 21 and 35, fans located in said fan-chambers, and means for actuating said fans.

35 11. In a smoke-preventing and gas-returning apparatus, fan-chambers 23 having fans therein, a chamber 21 intermediate said fan-chambers, a chamber 20 located below said chamber 21 and separated therefrom by a partition, a flue 27 leading from the chamber 21 to the chamber 20, a common outlet for said chambers 20 and 21, the latter leading to the flue 29, which discharges into a furnace, means for introducing steam into the chambers 21 and 20, and means for regulating the discharge of the commingled gases and steam and air through the flue 29.

45 12. In a smoke-preventing and gas-returning apparatus, a chamber 21 having a communication with the stack of the boiler, a fan-chamber 23, a chamber 20 located below said chamber 21, and having its lower portion

filled with water, an apertured plate located 55 near the surface of said water, the chambers 25 located exteriorly to said fan-chamber and having flues 26 leading thereto, said chambers 20 and 21 discharging at a common point and safety-valves therefor. 60

13. In a smoke-preventing and gas-returning apparatus, a chamber 21 adapted to receive the products of combustion, fan-chambers on either side thereof, a discharge from said chambers to a water-tank, a passage 65 leading from said water-tank back to said fan-chambers, the latter discharging into a furnace, and means for introducing steam and air into said products of combustion.

14. In a smoke-preventing and gas-returning apparatus, a blowing apparatus, having an intermediate chamber, and fan-chambers on the sides thereof, in combination with the stack of a boiler-furnace, a connection from said apparatus leading to a water-tank, a connection from said water-tank leading directly 75 to an outlet-flue of the furnace, an outlet from said water-tank leading back to said blowing apparatus, steam-jets located in the latter, and means for discharging the commingled air and steam into the furnace. 80

15. In a smoke-preventing and gas-returning apparatus, a blowing apparatus, a conduit leading therefrom to a furnace-stack, a water-chamber, a connection from said apparatus to the upper portion of said water-chamber, a connection from the latter leading to a fan-chamber of said blowing apparatus, a connection 27 leading to a lower chamber 20 of said apparatus, said chamber 90 having openings in the rear thereof, into which steam is adapted to be introduced, and means for conducting the commingled steam, products of combustion and air into the furnace.

16. In a smoke-preventing and gas-returning apparatus, a blowing apparatus consisting of upper and lower chambers 21 and 20, passages 35 located within said upper chamber and provided with the ports 36, a steam-pipe discharging into the latter and into said lower chamber, a series of dampers 37 located in said passage 35 and means for operating said dampers from the exterior. 100

DANIEL GOFF.

Witnesses:

WM. C. WIEDERSHEIM,
E. H. FAIRBANKS.