

G. S. BAKER.

MACHINE FOR SPREADING WAFERS, &c., WITH PASTE, &c.

APPLICATION FILED JUNE 9, 1902.

NO MODEL.

7 SHEETS—SHEET 1.

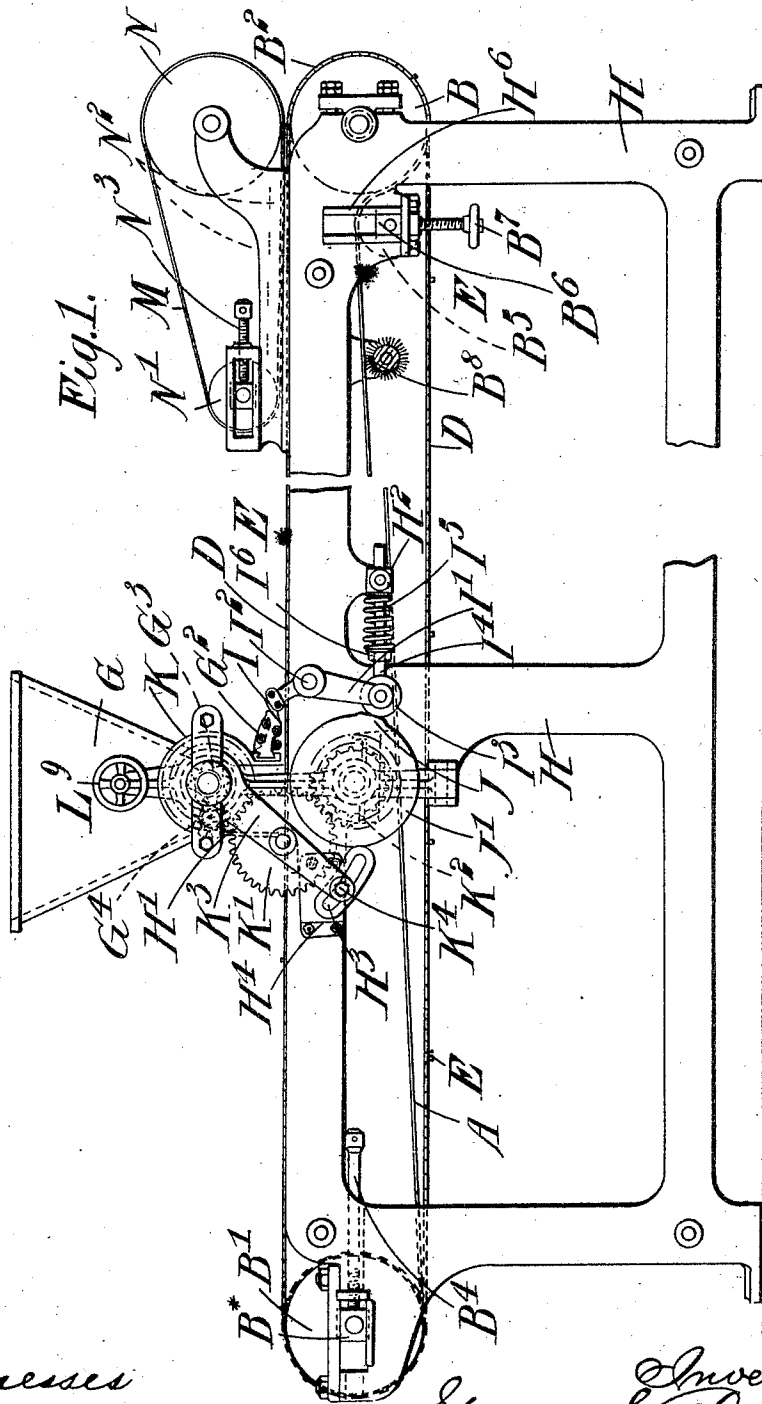

Fig. 1.

Witnesses
 W. K. Bunker
[Signature]

Inventor
 George S. Baker
 By *[Signature]*
 Attorney

G. S. BAKER.

MACHINE FOR SPREADING WAFERS, &c., WITH PASTE, &c.

APPLICATION FILED JUNE 9, 1902.

NO MODEL.

7 SHEETS—SHEET 2.

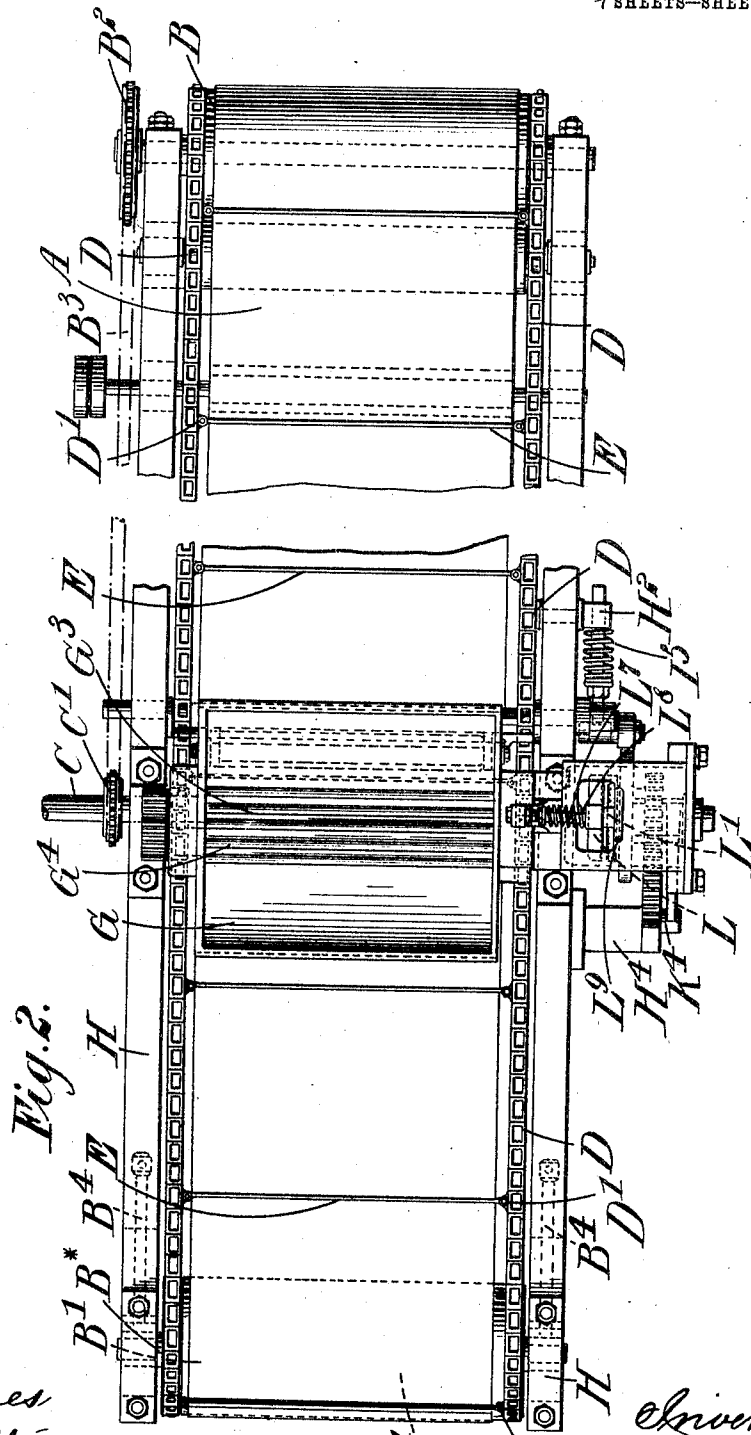

Fig. 2.

Witnesses
 W. K. Boullie
[Signature]

Inventor
 George S. Baker
 By *[Signature]*
 Attorney

No. 776,485.

PATENTED DEC. 6, 1904.

G. S. BAKER.
MACHINE FOR SPREADING WAFERS, &c. WITH PASTE, &c.

APPLICATION FILED JUNE 9, 1902.

NO MODEL.

7 SHEETS—SHEET 3.

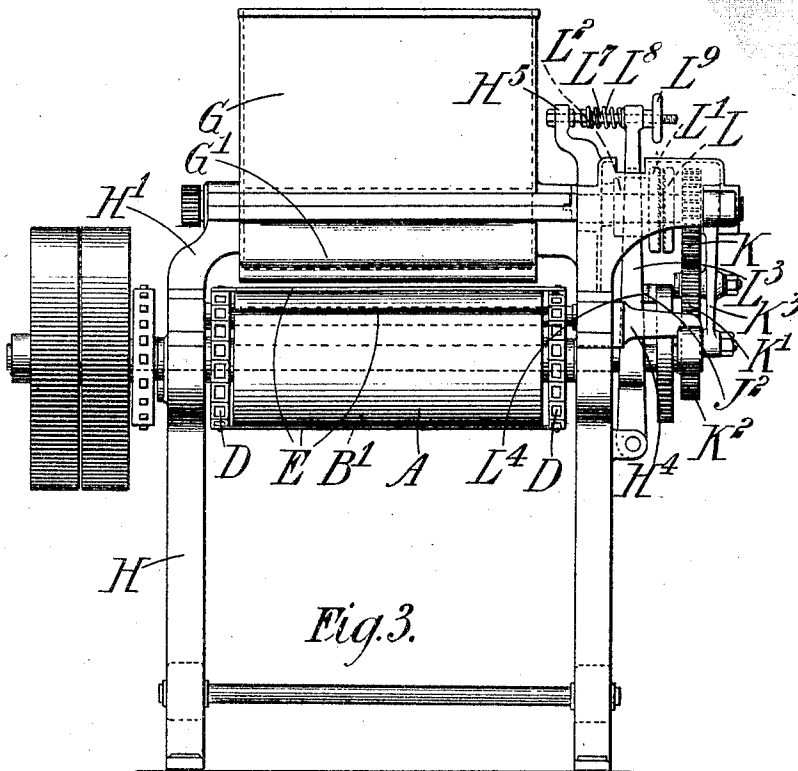

Fig. 3.

Witnesses
W. K. Borelin
C. H. Smith

Inventor
George S. Baker
By O. B. Faulster
Attorney

G. S. BAKER.

MACHINE FOR SPREADING WAFERS, &c., WITH PASTE, &c.

APPLICATION FILED JUNE 9, 1902.

NO MODEL.

7 SHEETS—SHEET 4.

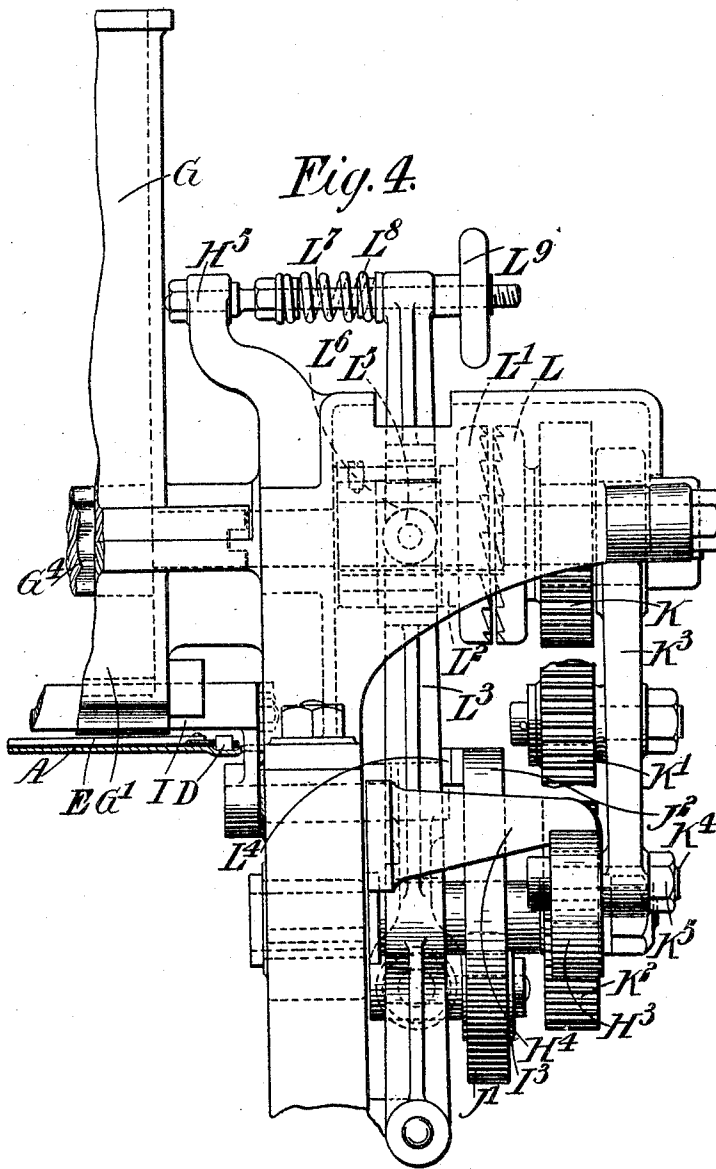

Witnesses:
 W. K. Bonelin
 W. H. H. H. H.

Inventor
 George S. Baker,
 By W. B. Paulsen,
 attorney.

No. 776,485.

PATENTED DEC. 6, 1904.

G. S. BAKER.

MACHINE FOR SPREADING WAFERS, &c., WITH PASTE, &c.

APPLICATION FILED JUNE 9, 1902.

NO MODEL.

7 SHEETS—SHEET 5.

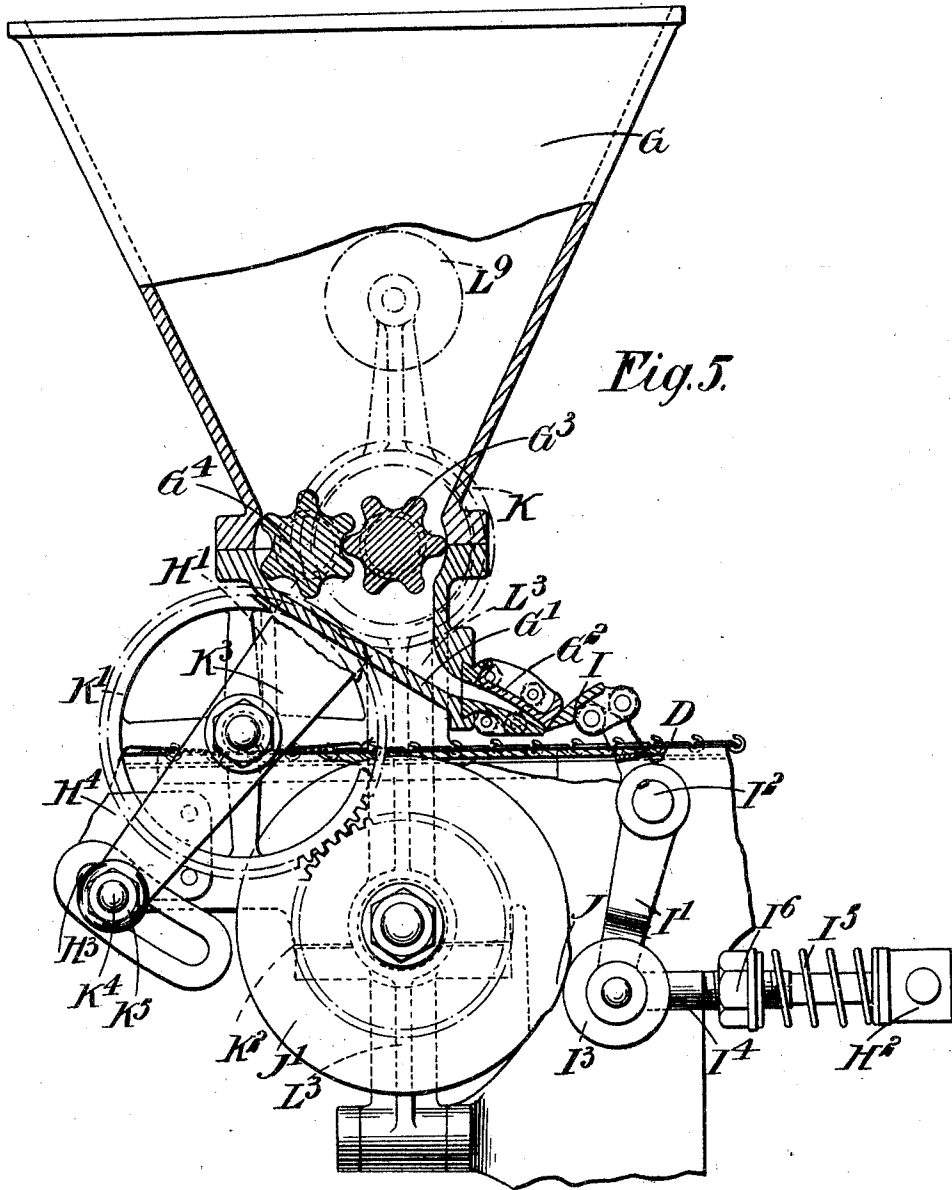

Fig. 5.

Witnesses
 W. K. Boullin
 W. H. H. H.

Inventor
 George S. Baker
 By W. H. H. H.
 Attorney

No. 776,485.

PATENTED DEC. 6, 1904.

G. S. BAKER.

MACHINE FOR SPREADING WAFERS, &c., WITH PASTE, &c.

APPLICATION FILED JUNE 9, 1902.

NO MODEL.

7 SHEETS—SHEET 6.

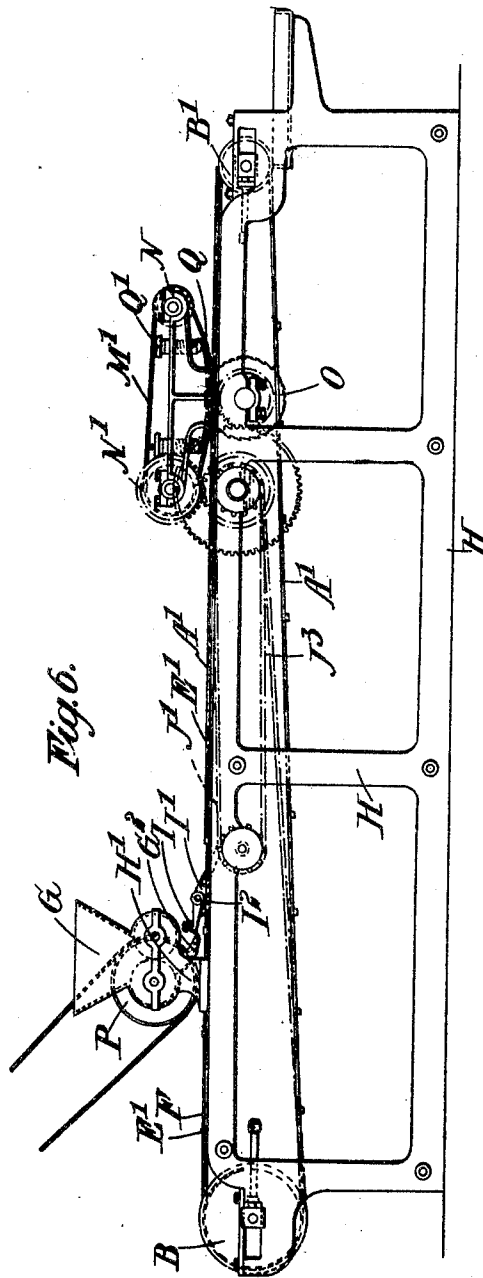

Witnesses
W. K. B. Smith
Montgomery

Inventor
George S. Baker
By Wm. B. Boulter
attorney

UNITED STATES PATENT OFFICE.

GEORGE SAMUEL BAKER, OF LONDON, ENGLAND.

MACHINE FOR SPREADING WAFERS, &c., WITH PASTE, &c.

SPECIFICATION forming part of Letters Patent No. 776,485, dated December 6, 1904.

Application filed June 9, 1902. Serial No. 110,843. (No model.)

To all whom it may concern:

Be it known that I, GEORGE SAMUEL BAKER, a subject of the King of England, residing at London, England, have invented certain new and useful Improvements in or Relating to Machines for Spreading Wafers or Similar Articles with Paste or Adhesive Substances, of which the following is a specification.

This invention relates to machines for spreading wafers and similar articles with paste or adhesive substances, and has for its chief object to provide a machine for spreading or coating one surface of a sheet of baked wafer with a paste or adhesive substance upon which a second wafer-sheet is then placed, the two wafer-sheets thereby being caused to adhere together and preferably being passed finally under rollers or their equivalent to settle the sheets together.

According to this invention the sheet of baked wafer to be coated is placed upon an endless band or conveyer and is passed under a hopper containing the paste or adhesive substance, a portion of which is delivered onto the surface of the wafer-sheet. After passing from under the hopper the second sheet of baked wafer is placed upon the coated surface of the first wafer-sheet and they are or may be then carried by the conveyer under a pressure band or roller to cause them to adhere. Saws or other appropriate cutting devices are provided for dividing the completed wafer into convenient strips or sections.

Referring to the drawings, Figure 1 is a side elevation, Fig. 2 a plan, and Fig. 3 an end elevation, of a wafer-spreading machine constructed in accordance with my invention. Fig. 4 is a side elevation, partly in section, and Fig. 5 an end view, of the hopper and parts connected therewith. Fig. 6 is a side elevation, and Fig. 7 a plan, of a modified construction of machine.

Referring more particularly to Figs. 1 to 5, the endless band or conveyer A is mounted at each end on rollers B B', and the roller B has fixed to it a sprocket-wheel B², which is rotated from a sprocket-wheel C' on the main driving-shaft C by a chain B³. D D are chains placed at each side of the conveyer A and provided at intervals with lugs D', to

which are attached bars or rods E, that extend across the band and lie in close contact with the surface thereof. These chains move at the same speed as the band, which is divided transversely by the bars into trays or divisions, each adapted to receive a sheet of baked wafer. G is the hopper containing the paste or adhesive substance for coating the wafer and is carried on supports or brackets H' on the machine-frame H. The bottom G' of the hopper slopes downward to a chute or delivery-spout G², down which the paste is forced by corrugated or fluted rollers G³ G⁴, (see Figs. 4 and 5,) which are supported in bearings in the lower part of the hopper. At the delivery end of the spout, which is situated in close proximity to the band, is mounted a reciprocating knife or divider I, carried at one end of a bell-crank or rocking lever I', which is pivoted to the machine-frame I². The other end of the lever I' carries a roller I³ and has also pin-jointed to it one end of a sliding rod I⁴. The knife is operated to sever or cut off a portion of the paste and also to close the mouth of the spout and prevent any more than the predetermined amount of paste being delivered. The lever I' is moved in one direction by a cam J, mounted on a disk J', carried by the driving-shaft C and when free from the raised part of the cam is returned to again open the mouth of the spout by a spring I⁵, mounted between a nut I⁶ on the rod I⁴ and a boss H² on the frame H, or the knife may be returned by a weight or it may be reciprocated in both directions by an eccentric or otherwise. The feed-rollers G³ G⁴ in the hopper mesh with each other, and the roller G³ is driven from the shaft C by pinions K K' K². The pinion K² is fast on the shaft C, and the pinion K' is mounted in a lever K³, one end of which is carried loosely on the shaft of the roller G³, the other end being provided with a bolt K⁴, adapted to slide in a slot H³ in a bracket H⁴ on the machine-frame. This end of the lever can be clamped in the slot by a nut K⁵, and by moving the lever various-sized pinions can be employed in place of the pinion K², so as to vary the speed of rotation of the rollers. The pinion K is mounted loosely on the shaft of the roller G³

and has formed integral with it or connected to it one member L of a clutch, the other member L' of which is mounted on a sliding sleeve L², connected to the roller-shaft by a groove and feather or other suitable connection. The sleeve L² is operated to engage or disengage the clutch members at the requisite time by a lever L³, having a projection L⁴, which is engaged by a cam J² on the disk J'. This cam is so arranged that the clutch members are disengaged simultaneously with the closing of the mouth of the spout by the knife I. The lever L³ is connected to the clutch member by rollers or projections L⁵, which are adapted to rest in a groove L' on the sleeve L². The lower end of the lever is pivoted to the machine-frame and has passed through a hole in its upper end a rod L⁷, carried in a bracket H⁵, between which and the end of the lever is disposed a spring L⁸, the tension of which can be adjusted by a hand wheel or nut L⁹, fitted on the end of the rod L⁷. The roller B' is mounted in sliding bearings B, which can be moved laterally by adjusting-screws B⁴. After passing round the roller the band A is passed over a jockey-roller B⁵, mounted in bearings B⁶ in a bracket H⁶ and capable of adjustment therein by a screw B⁷. The chains D do not pass over the jockey-roller, but are led under it direct to the roller B', so as to permit of the band being cleaned by a brush B⁸ or other rubber or cleaning device.

One sheet of baked wafer is placed in each division of the band as it approaches the hopper, and as the sheet passes under the spout G² the feed and dividing mechanism, above described, are set in motion and a portion of paste is delivered onto the sheet, after which the spout is again closed and the feed-rollers stopped, so as to prevent any paste falling onto the band itself. After passing from under the hopper a second sheet of baked wafer is placed on top of the coated surface of the first sheet, and as the superposed sheets approach the delivery end of the band they are passed under an endless pressure-band M, mounted over the band A and carried by rollers N N'. The band M is preferably so arranged that it approaches nearer to the surface of the conveyer A in such a way as to give a gradually-increasing pressure to the wafers to cause them to adhere and settle, or the bands A and M may be arranged parallel to each other.

In order to increase the pressure of the band M, weights N² are or may be placed on the inside of the band. The roller N' is adjustable to regulate the tension of the band M by a screw N³, and the roller N can be driven from the main shaft by a chain gearing or otherwise.

The cams J J² for operating the dividing-knife and feed-rollers in the hopper are arranged so as to deliver a portion of paste once

in every revolution of the cam-shaft; but, if desired, they may be arranged to deliver a portion of paste twice in each revolution or otherwise, according to the speed at which the endless band is traveling.

Referring to the modified construction of machine shown in Figs. 6 and 7, the carrier or conveyer consists of a number of ribbons A', preferably of steel and mounted on rollers B B'. Each ribbon is provided at intervals with bars or blocks E', and in order to retain the bars on the various ribbons in alignment with each other the roller B is provided with studs or projections B⁹, which engage with holes or openings A² on the ribbons A', which are further prevented from moving laterally by means of flanges B¹⁰ on the rollers B B'. The superposed sheets of wafer pass under a pressure-band, which in this case also consists of a number of ribbons M', and the roller N' is driven from the shaft C by gear-wheels or pinions. The pressure-band is forced onto the wafers by a spring-plate Q, provided at each corner with adjusting-screws Q', and is slotted to allow free movement to the saws O. Before passing from under the ribbons M' the wafer is operated upon by saws O, which are mounted between the ribbons and cut the wafer longitudinally into strips. Additional saws are placed at the outer edges of the sheet to trim its edges, and the saws are all mounted on a single shaft O', which is driven from the main shaft C by toothed gearing. The shaft carrying the cam to operate the knife I is in this case driven from the shaft C by a chain J³. The feed-rollers, which in this case are smooth, are driven through toothed gearing from a belt-pulley P.

If it is desired to cut the strips of the wafer transversely as well as longitudinally, additional saws may be provided at the delivery end of the machine for this purpose.

What I claim as my invention, and desire to secure by Letters Patent, is—

1. In a machine for spreading paste or the like, the combination of an endless conveyer-band, a hopper for the paste, intermeshing feed-rollers in the hopper, a divider at the outlet of the hopper cooperating with the feed-rollers to cut off a portion of paste and close the outlet of the hopper, a driving-clutch on the feed-rollers, an operating-arm for the clutch, means for intermittently operating the clutch and the divider, a change-wheel between the feed-rollers and the operating means, an adjustable support for the wheel and a presser-band mounted above the conveyer-band at one end of the machine substantially as described.

2. In a machine for spreading paste or the like the combination with an endless conveyer-band of a hopper for the paste, intermeshing feed-rollers in the hopper, a divider at the outlet of the hopper cooperating with the feed-rollers to cut off a portion of paste and close

the outlet of the hopper, a driving-clutch on the feed-rollers, an operating-arm for the clutch, a rotating shaft, a cam on the shaft for the clutch-arm, a cam on the shaft for the divider, a change-wheel mounted on an adjustable support, a gear-wheel on the cam-shaft for driving the change-wheel, a gear-wheel on the roller-clutch meshing with the change-wheel and a loaded presser-band mounted above the conveyer-band at one end of the machine substantially as described.

3. In a machine for spreading paste or the like, the combination with an endless conveyer-band, of a hopper for the paste, intermeshing feed-rollers in the hopper, a divider at the outlet of the hopper cooperating with the feed-rollers to cut off a portion of paste and close the outlet of the hopper, a driving-clutch on the feed-rollers, an operating-arm for the clutch, a change-wheel for driving the feed-rollers, an adjustable support for the change-wheel, a rotating shaft, a cam on the shaft for the clutch-operating arm, a cam on the shaft for the divider, a gear-wheel on the shaft for rotating the change-wheel, a gear-wheel on the roller-clutch meshing with a change-wheel, a loaded presser-band mounted above the conveyer-band at one end of the machine and cutters substantially as described.

4. In a machine for spreading paste or the like, the combination of an endless conveyer-band, a hopper for the paste, intermeshing feed-rollers in the hopper, a divider at the outlet of the hopper cooperating with the feed-rollers to cut off a portion of paste and close the outlet of the hopper, a driving-clutch on the feed-rollers, an operating-arm for the clutch, a change-wheel for rotating the feed-rollers, an adjustable support for the change-wheel, a rotating shaft, a cam on the shaft for the clutch-operating arm, a cam on the shaft for the divider, a gear-wheel on the shaft for rotating the change-wheel, a loaded presser-band mounted above the conveyer-band at one end of the machine, bars carried by chains so as to divide the conveyer-band transversely into trays adapted to lie in close contact with the upper or tight side of the band and means whereby the band is carried away from the bars on its return or slack side substantially as and for the purpose described.

5. In a machine for spreading paste or the like, the combination with an endless conveyer-band, of a hopper for the paste, feed-rollers in the hopper, a divider at the outlet of the hopper cooperating with the feed-rollers to cut off a portion of paste and close the outlet of the hopper, a driving-clutch on the feed-rollers, an operating-arm for the clutch, a change-wheel for rotating the feed-rollers, an adjustable support for the change-wheel, a rotating shaft, a cam on the shaft for the clutch-operating arm, a cam on the shaft for the divider, a gear-wheel on the shaft for rotating the change-wheel, a loaded presser-band mounted

above the conveyer-band at one end of the machine, bars carried by chains dividing the conveyer-band transversely into trays, and adapted to lie in close contact with the upper or tight side of the band, means whereby the band is carried away from the bars on its return side and a scrubber for the band substantially as described.

6. In a machine for spreading paste or the like, the combination with an endless conveyer-band, of a hopper for the paste, feed-rollers in the hopper, a divider at the outlet of the hopper cooperating with the feed-rollers to cut off a portion of paste and close the outlet of the hopper, a driving-clutch on the feed-rollers, an operating-arm for the clutch, a change-wheel for rotating the feed-rollers, an adjustable support for the change-wheel, a rotating shaft, a cam on the shaft for the clutch-operating arm, a cam on the shaft for the divider, a gear-wheel on the shaft for rotating the change-wheel, a loaded presser-band mounted above the conveyer-band at one end of the machine, bars carried by chains dividing the conveyer-band transversely into trays and adapted to lie in close contact with the upper or tight side of the band, a jockey-roller carrying the band away from the bars on its return or slack side, a scrubber for the band, and rotary cutters mounted at the delivery end of the band substantially as and for the purpose described.

7. In a machine for spreading paste or the like, the combination with an endless conveyer-band consisting of a number of separate ribbons provided on their upper surface with bars dividing the band transversely into trays, of a hopper, feed-rollers in the hopper, a spout to the hopper, a divider on the spout cooperating with the feed-rollers to cut off a portion of paste and close the spout, a driving-clutch on the feed-roller shaft, an operating-arm for the clutch, a change-wheel for rotating the feed-rollers, an adjustable support for the change-wheel, a rotating shaft, a cam on the shaft for the clutch-operating arm, a cam on the shaft for the divider, a gear-wheel on the shaft for rotating the change-wheel, a loaded presser-band mounted above the conveyer-band at one end of the machine, and rotary cutters mounted at the delivery end of the conveyer-band substantially as and for the purpose described.

8. In a machine for spreading paste or the like, the combination with an endless conveyer-band, of a hopper for the paste, a delivery-spout for the hopper having its delivery end arranged in proximity to the band, a feeding device in the hopper, a divider arranged at the delivery end of the spout and adapted to have a reciprocable movement in a path across the delivery end of the spout, a rocking lever carrying the said divider and means for operating the rocking lever to cause the divider to intermittently cut off the exact quantity of

paste intended to be delivered onto the articles carried by the band and said divider in its movement forming a closure for the delivery end of the spout to prevent any further amount of the paste being delivered through said delivery end.

9. In a machine for spreading paste or the like, the combination with an endless conveyer-band, of a hopper for the paste, a delivery-spout for the hopper having its delivery end arranged in proximity to the band, a divider arranged at the delivery end of the spout and adapted to have a reciprocable movement in a path across the delivery end of the spout, a rocking lever carrying the said divider and means for operating the rocking lever to cause the divider in its movement to form a closure for the delivery end of the spout and intermittently cut off the exact quantity of paste intended to be delivered onto the articles carried by the band and prevent any further amount of paste being delivered through said delivery end.

10. In a machine for spreading paste or the like, the combination with an endless conveyer-band, of a hopper for the paste, a delivery-spout for the hopper having its delivery end arranged in proximity to the band, a feeding device in the hopper, a divider arranged at the delivery end of the spout, and adapted to have a reciprocable movement in a path across the delivery end of the spout, a rocking lever carrying the said divider and means for intermittently operating the rocking lever and the feeding device to cause said feeding device and divider to cooperate to intermittently cut off the exact quantity of paste intended to be delivered onto the articles carried by the band and cause said divider to close the forward end of the spout and to prevent any further amount of paste being delivered through said delivery end.

11. In a machine for spreading paste or the like, the combination with an endless conveyer-band, of a hopper for the paste, a delivery-spout for the hopper having its delivery end arranged in proximity to the band, feeding-

rollers arranged in the hopper, a divider arranged at the delivery end of the spout and adapted to have a reciprocable movement in a path across the delivery end of the spout, a rocking lever carrying said divider, means for operating the feeding-rollers and rocking lever to cause said feeding-rollers and divider to cooperate to intermittently cut off the exact quantity of paste intended to be delivered onto the articles carried by the band and to cause said divider to close the delivery end of the spout to prevent any further amount of paste being delivered through said delivery end, a rotatable shaft, means intermediate said shaft and the shaft of one of the feed-rollers comprising intermeshing pinions, a lever carrying one of said pinions, one end of which lever is loosely mounted on the shaft of one of the feed-rollers and means for adjustably securing the other end of the lever, as and for the purpose specified.

12. In a machine for spreading paste or the like, the combination with an endless conveyer-band, of a hopper for the paste, a delivery-spout for the hopper having its delivery end arranged in proximity to the band, a feeding device in the hopper, a divider arranged at the delivery end of the spout and adapted to have a reciprocable movement in a path across the delivery end of the spout, a rocking lever carrying the divider, a presser-band mounted above the conveyer-band at one end of the machine, and means for operating the rocking lever to cause the divider to intermittently cut off the exact quantity of paste intended to be delivered onto the articles carried by the band and close the delivery end of the spout to prevent any further amount of paste being delivered through said delivery end.

In testimony whereof I have signed my name to this specification in the presence of two subscribing witnesses.

GEORGE SAMUEL BAKER.

Witnesses:

FRANK CHAPLIN,
HENRY JOHN BARNETT.