



- (51) **International Patent Classification:**
B60C 11/24 (2006.01) *G01D 11/24* (2006.01)
- (21) **International Application Number:**
PCT/US2019/038872
- (22) **International Filing Date:**
25 June 2019 (25.06.2019)
- (25) **Filing Language:** English
- (26) **Publication Language:** English
- (30) **Priority Data:**
62/691,948 29 June 2018 (29.06.2018) US
- (71) **Applicant:** TYRATA, INC. [US/US]; 101 West Chapel Hill Street, Suite 200, Durham, North Carolina 27701 (US).
- (72) **Inventors:** KOESTER, David Alan; 512 Meadowood Drive, Burlington, North Carolina 27215 (US). SUMMERS III, James Barton; 4900 Kinross Court, Raleigh, North Carolina 27613 (US).
- (74) **Agent:** HATFIELD, Scott; Sage Patent Group, P.O. Box 30789, Raleigh, North Carolina 27622-0789 (US).
- (81) **Designated States** (*unless otherwise indicated, for every kind of national protection available*): AE, AG, AL, AM,

AO, AT, AU, AZ, BA, BB, BG, BH, BN, BR, BW, BY, BZ, CA, CH, CL, CN, CO, CR, CU, CZ, DE, DJ, DK, DM, DO, DZ, EC, EE, EG, ES, FI, GB, GD, GE, GH, GM, GT, HN, HR, HU, ID, IL, IN, IR, IS, JO, JP, KE, KG, KH, KN, KP, KR, KW, KZ, LA, LC, LK, LR, LS, LU, LY, MA, MD, ME, MG, MK, MN, MW, MX, MY, MZ, NA, NG, NI, NO, NZ, OM, PA, PE, PG, PH, PL, PT, QA, RO, RS, RU, RW, SA, SC, SD, SE, SG, SK, SL, SM, ST, SV, SY, TH, TJ, TM, TN, TR, TT, TZ, UA, UG, US, UZ, VC, VN, ZA, ZM, ZW.

(84) **Designated States** (*unless otherwise indicated, for every kind of regional protection available*): ARIPO (BW, GH, GM, KE, LR, LS, MW, MZ, NA, RW, SD, SL, ST, SZ, TZ, UG, ZM, ZW), Eurasian (AM, AZ, BY, KG, KZ, RU, TJ, TM), European (AL, AT, BE, BG, CH, CY, CZ, DE, DK, EE, ES, FI, FR, GB, GR, HR, HU, IE, IS, IT, LT, LU, LV, MC, MK, MT, NL, NO, PL, PT, RO, RS, SE, SI, SK, SM, TR), OAPI (BF, BJ, CF, CG, CI, CM, GA, GN, GQ, GW, KM, ML, MR, NE, SN, TD, TG).

Published:
— with international search report (Art. 21(3))

(54) **Title:** STRUCTURES AND METHODS PROVIDING TREAD SENSOR INTEGRATION

Figure 12
Cross sectional view of sensor housing including TPMS unit

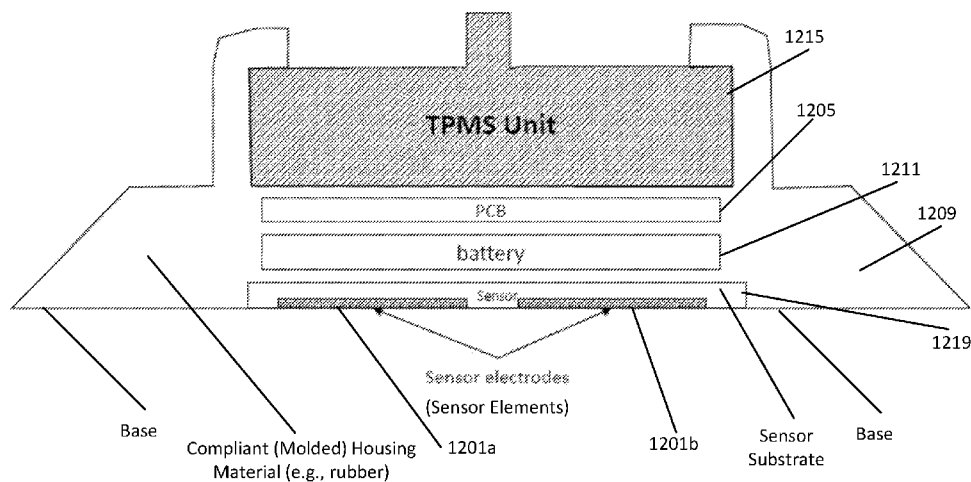

(57) **Abstract:** A tire monitoring system may include first and second sensor elements, a circuit board, and a housing. The circuit board includes control circuitry coupled with at least one of the first and second sensor elements, wherein the control circuitry is configured to generate tire tread information based on an electrical response of at least one of the first and second sensor elements. The housing includes a housing material that surrounds the circuit board in a direction parallel with respect to a surface of the circuit board. Related methods are also discussed.



STRUCTURES AND METHODS PROVIDING TREAD SENSOR INTEGRATION

TECHNICAL FIELD

The present disclosure relates generally to tires, and more particularly, to tire sensors and related methods.

BACKGROUND

Currently, tire pressure sensors may be provided in vehicle tires. Such sensors may be used to automatically monitor tire pressure, and a warning (e.g., a warning light) may be provided to the driver when low pressure is detected. Other aspects of the tire, however, may require manual monitoring and failure to adequately monitor such aspects may cause issues relating to safety. Accordingly, improved monitoring of vehicle tires may be desired.

SUMMARY

According to some embodiments of inventive concepts, a tire monitoring system may include first and second sensor elements, a circuit board, and a housing. The circuit board may include control circuitry coupled with at least one of the first and second sensor elements, wherein the control circuitry is configured to generate tire tread information based on an electrical response of at least one of the first and second sensor elements. The housing may include a housing material that surrounds the circuit board in a direction parallel with respect to a surface of the circuit board.

According to some other embodiments of inventive concepts, a method may provide a tire monitoring system. First and second sensor elements may be provided, and a circuit board may be provided including control circuitry coupled with at least one of the first and second sensor elements. The control circuitry may be configured to generate tire tread information based on an electrical response of at least one of the first and second sensor elements. A housing may be formed on the circuit board using a housing material that surrounds the circuit board in a direction parallel with respect to a surface of the circuit board.

BRIEF DESCRIPTION OF THE DRAWINGS

The accompanying drawings, which are included to provide a further understanding of the disclosure and are incorporated in and constitute a part of this application, illustrate certain non-limiting embodiments of inventive concepts. In the drawings:

Figure 1 is a photograph illustrating a lid and a carrier according to some embodiments of inventive concepts together with a 1 Euro coin provided to illustrate scale;

Figure 2 is a photograph illustrating a rubber mount according to some embodiments of inventive concepts;

Figure 3 is a cross-sectional/side view of a tread wear sensor mounted inside a carrier of Figure 1 according to some embodiments of inventive concepts;

Figure 4 to a top view of a tread wear sensor of Figure 3 according to some embodiments of inventive concepts;

Figure 5 is a cross-sectional/side view of a tread wear sensor mounted in the carrier of Figure 1 with a battery and a printed circuit board according to some embodiments of inventive concepts;

Figure 6 is a block diagram illustrating elements of a tire monitoring system according to some embodiments of inventive concepts;

Figures 7A and 7B are schematic diagrams illustrating operation of a tread wear sensor according to some embodiments of inventive concepts;

Figure 8 illustrates a printed circuit board PCB that may be used according to some embodiments of inventive concepts;

Figure 9 illustrates a dielectric substrate that may be used according to some embodiments of inventive concepts;

Figure 10 illustrates a battery that may be used according to some embodiments of inventive concepts;

Figure 11 illustrates a housing that may be used according to some embodiments of inventive concepts;

Figure 12 is a cross-sectional view of a sensor housing including a tire pressure monitoring system according to some embodiments of inventive concepts;

Figure 13 illustrates top and bottom views of the sensor housing of Figure 12 according to some embodiments of inventive concepts;

Figure 14 is a cross-sectional view illustrating a sensor housing according to some embodiments of inventive concepts; and

Figure 15 is a cross-sectional view of a sensor housing mounted on an inside surface of a tire according to some embodiments of inventive concepts.

DETAILED DESCRIPTION

Inventive concepts will now be described more fully hereinafter with reference to the accompanying drawings, in which examples of embodiments of inventive concepts are shown. Inventive concepts may, however, be embodied in many different forms and should not be construed as limited to the embodiments set forth herein. Rather, these embodiments are provided so that this disclosure will be thorough and complete, and will fully convey the scope of present inventive concepts to those skilled in the art. It should also be noted that these embodiments are not mutually exclusive. Components from one embodiment may be tacitly assumed to be present/used in another embodiment.

The following description presents various embodiments of the disclosed subject matter. These embodiments are presented as teaching examples and are not to be construed as limiting the scope of the disclosed subject matter. For example, certain details of the described embodiments may be modified, omitted, or expanded upon without departing from the scope of the described subject matter.

According to some embodiments of inventive concepts, tire tread monitoring systems (TTMS) may be used to monitor vehicle tire tread wear. A tire tread monitoring system according to such embodiments may use a sensor including two electrodes that may be formed, for example, by printing or other means on a rigid or flexible dielectric substrate. There may be different ways to package such tread wear sensors for tire deployment. One approach for Tire Pressure Monitoring Systems TPMS is a package scheme like the one presented by VDO (<http://www.vdo.com/passenger-cars/tire-pressure-monitoring-systems-tpms/the-vdo-redi-sensor/>). In this approach, the TPMS sensors, battery, sense electronics and RF communications are all housed inside a small carrier roughly 1 inch in diameter as shown in Figure 1 including a carrier and a lid. The lid is placed over the contents of the carrier and sealed, and this “package” is then placed inside a rubber mount (shown in Figure 2) that is attached to the inside surface of the tire by an adhesive. The base of the package carrier may thus be mounted adjacent to the

inside surface of the tire. According to some embodiments of inventive concepts, a tread wear sensor may be mounted in the same carrier and share the power management and RF communications hardware used for TPMS. According to some embodiments of inventive concepts, methods may be provided to integrate tire tread wear and pressure monitoring systems. U.S. Provisional Patent Application No. 62/650,714 (“Structures and Methods Providing Sensor-Package Integration”) discusses integration of a tread sensor into a standard tire pressure monitoring system (TPMS) style package similar to that described by VDO. The disclosure of U.S. Provisional App. No. 62/650,714 is hereby incorporated herein in its entirety by reference.

Tread wear sensor structures/designs and methods according to some embodiments disclosed herein may enable integration with a tire pressure monitor into a carrier/package.

According to some embodiments, the tread wear sensor may be placed at the base of the carrier (also referred to as the bottom of the carrier) to position the sensor close to the inner tire surface. In some TPMS designs, the battery may be placed at the bottom of the carrier.

According to some embodiments, the tread wear sensor (e.g., the tread wear sensor elements) may be positioned between the battery and a base of the carrier. This design may position the tread wear sensor close to the tire surface (e.g., as close as possible) and may reduce/avoid RF (radio frequency) interference from the battery and/or electronics in the package. According to some embodiments, an epoxy or similar underfill or potting material may be used underneath and/or above the tread wear sensor to secure the tread wear sensor. In addition, this underfill/potting material may protect the tread wear sensor from harsh operating conditions including varying humidity and/or mechanical shock/vibration. The orientation of the tread wear sensor could be either upward facing or downward facing.

Figure 3 is a cross-sectional/side view of a tread wear sensor (labeled “sensor”) mounted inside the carrier of Figure 1. As shown, the tread wear sensor may be provided adjacent a base of the carrier, and an underfill/potting material may be provided on the tread wear sensor. Moreover, sensor leads (e.g., pigtail sensor leads) from the sensor may extend through the underfill/potting material to provide electrical coupling with control circuitry. Figure 4 is a top view of the tread wear sensor of Figure 3 in the carrier. For purposes of illustration, the tread wear sensor is shown through the underfill/potting material in Figure 4, but it will be understood that the underfill/potting material may cover the tread wear sensor (except for the pigtail sensor leads).

Figure 5 is a cross-sectional/side view of the tread wear sensor mounted inside the carrier of Figure 1 with a battery and printed circuit board PCB. The pigtail sensor leads (“leads”) of the tread wear sensor may extend out of the carrier and may wrap around the battery and printed circuit board PCB. The leads of the tread wear sensor may then be attached to the PCB by soldering (surface mount technology), conductive epoxy, or by a connector or socket. It may be useful to include additional dielectric shielding (not shown in Figure 5) between the battery and the tread wear sensor. According to some embodiments, the underfill/potting material may provide adequate dielectric shielding, but in other embodiments, different/additional layers may be added.

Additional modifications to the tread wear sensor may further facilitate integration with the tire pressure monitor in the final package. According to some embodiments, the tread wear sensor may be encapsulated by applying a thin Kapton, PET (polyethylene terephthalate), or other layer over the top surface of the tread wear sensor after printing. This encapsulation may extend down the length of the leads but leave exposed the ends of the leads for subsequent electrical connection. Metal vias or feedthroughs may be provided in the tread wear sensor substrate (e.g., Kapton), particularly at the ends of the leads to improve subsequent electrical connection. These metal vias/feedthroughs may allow electrical and mechanical interface to the printed traces from either the top or bottom side of the sensor substrate. This may provide a thick, mechanically robust metal layer for connection either by solder, conductive epoxies or socket connectors, allowing for electrical connection from either side of the substrate. In addition, a metal layer may be provided on the backside of the sensor substrate (away from the carrier base and the tire surface) to provide an effective RF ground plane. This ground plane layer may be continuous or discontinuous based on RF characteristics of the sensor.

According to some embodiments, the sensor elements may be provided on a flexible sensor substrate, and mounted so that the sensor elements are between the flexible sensor substrate and the carrier base, and so that the sensor elements are between the flexible sensor substrate and the inner surface of the tire. Moreover, a metal layer may be provided (e.g., as an RF ground plane) on the backside of the sensor substrate so that the sensor substrate is between the metal layer and the sensor elements. In such embodiments, the sensor elements may be between the backside metal layer and the carrier base, and between the backside metal layer and the inner surface of the tire.

A lid (e.g., as shown in Figure 1) may be provided over the carrier of Figure 5 to seal the tread wear sensor, battery, and PCB within the carrier/lid package, and the carrier base may be mounted on an inside surface of the tire to be monitored. The structure of Figure 5 may thus be used to provide an integrated tread wear sensor and pressure monitor. While one PCB is shown in Figure 5 for purposes of illustration, control circuitry may be provided using one or a plurality of PCBs. Moreover, a pressure sensor (e.g., a micro-electro-mechanical-system MEMS pressure sensor) may be provided (inside the carrier/lid package) with the PCB (e.g., mounted on the PCB) to provide tire pressure monitoring. Components of the integrated tire monitoring system are illustrated in the block diagram of Figure 6.

As shown in Figure 6, circuitry may be provided in/on the printed circuit board to provide controller 601, wireless interface 603, and/or pressure sensor 605. Controller 601 and/or wireless interface 603 may be implemented using one or more integrated circuit devices that may be mounted (soldered) on PCB (or otherwise coupled with PCB). Moreover, pressure sensor 605 may be a MEMS pressure sensor that is provided as a discrete device on/in the PCB, and/or pressure sensor 605 may be integrated with circuits used to provide controller 601 and/or wireless interface 603. As shown in Figure 5, battery 609 may be positioned between the PCB and tread wear sensor 607 in the carrier, with the tread wear sensor positioned between battery 609 and the base of the carrier (which is mounted to the inside surface of the tire).

Controller 601 (also referred to as a control circuit or control circuitry) may thus generate tire pressure information based on signals received from pressure sensor 605, and controller 601 may thus generate tread wear information based on signals received from tread wear sensor 607. The tire pressure information and/or tread wear information may thus be transmitted through wireless communication interface 603 (also referred to as a wireless interface circuit or wireless interface circuitry) to a receiver in the vehicle that provides the information to a controller in the vehicle. The wireless interface 603 may thus provide wireless communication (e.g., radio communication) with a receiver in the vehicle to facilitate wireless transmission of tire pressure and/or tread wear information from the spinning tire to the vehicle controller. The wireless interface 603 may also receive information (e.g., instructions) from a transmitter in the vehicle, such as instructions to transmit tire pressure and/or tread wear information. While pressure and tire wear sensors are discussed by way of example, other sensors (e.g., a temperature sensor) may also be included in the tire monitoring system. With a temperature sensor, for example,

controller 601 may generate tire temperature information based on signals received from the temperature sensor, and controller 601 may transmit such temperature information through wireless communication interface 603 to the receiver in the vehicle.

Operations of the tire monitoring system may be performed by controller 601 and/or wireless communication interface 603. For example, controller 601 may control wireless communication interface 603 to transmit communications (e.g., tread wear and/or tire pressure information) through wireless communication interface 603 over a radio interface to a vehicle receiver and/or to receive communications (e.g., requests for information) through wireless communication interface 603 from a vehicle transmitter over a radio interface. Moreover, modules may be stored in memory, and these modules may provide instructions so that when instructions of a module are executed by controller 601, controller 601 performs respective operations (e.g., operations discussed below with respect to the claims).

Figures 7A and 7B are schematic diagrams illustrating operation of a tread wear sensor according to some embodiments of inventive concepts. In the illustration of Figures 7A and 7B, the tread wear sensor is shown on an inside surface of the tire without the other elements of Figures 5/6 to more clearly illustrate operations thereof. Operation of the tread wear sensor is based on the mechanics of how electric fields interact with different materials. As shown in Figures 4 and 7B, the tread wear sensor (TWS) includes two electrically conductive sensor elements (also referred to as sensor electrodes) side-by-side and very close to each other, and the two sensor elements are positioned adjacent to the inside of the tire as shown in Figures 7A and 7B. As shown in Figure 5, the carrier base may be between the sensor elements and the inside surface of the tire, but the carrier has been omitted from Figures 7A and 7B for each of illustration.

The controller 601 may thus apply an oscillating electrical voltage to one of the sensor elements while the other sensor element is grounded to generate an electrical field between the two sensor elements (shown as arcs in Figures 7A and 7B). While most of the electric field may pass directly between edges of the sensor elements, some of the electric field arcs from the face of one electrode to the face of the other electrode through the tire tread (shown by arcs in Figures 7A and 7B). The tire rubber and tread structure interfere with this “fringing field,” and by measuring this interference through the electrical response of the grounded sensor element, the controller 601 may thus determine a thickness of the tire above the tread wear sensor.

According to further embodiments of the present disclosure, a modification of the above disclosed integration scheme is presented where the tread sensor (also referred to as a tread wear sensor), its associated electronics, battery and communications chips are molded inside a rubber mount having outer dimensions similar to those shown in the “boot” of Figure 2, instead of placing the sensor inside a plastic housing including a lid and carrier of Figure 1. Aspects of such embodiments are discussed below:

A custom Printed Circuit PC Board is illustrated in Figure 8 according to some embodiments of inventive concepts. The custom PC board may include source electronic signal and sense, computation, RF data transmission and power management circuitry. Such circuitry may be provided using one or more discrete and/or integrated circuit (IC) electronic devices interconnected using conductive traces of the PC board. The PCB of Figure 8 may provide circuitry as discussed above with respect to PCB of Figure 5 and/or controller 601 of Figure 6.

The sensor is illustrated in Figure 9 according to some embodiments of inventive concepts. The sensor interfaces with the tire and is electrically connected to the PCB of Figure 8. As shown, the sensor includes two electrodes (Electrode 1 and Electrode 2) on a dielectric substrate, and the sensor may be mounted on an inside surface of the tire (opposite a tread block) so that the electrodes are between the dielectric substrate and the inside surface of the tire. The sensor (e.g., tread wear sensor or a tread monitoring sensor) of Figure 9 may be provided using structures as discussed above, for example, with respect to Figures 3, 4, 5, 6, 7A, and/or 7B.

The battery of Figure 10 may be a coin style battery according to some embodiments of inventive concepts. The power source for the sensor may be a coin cell battery but could be another stored energy device. The battery of Figure 10 may be used as discussed above with respect to the battery of Figures 5 and 6.

A rubber housing or “boot” according to some embodiments of inventive concepts is illustrated in Figures 11, 12, 13 and/or 14. The housing may be a rubber housing specific to the tread sensor components of Figures 8-10, the rubber housing may be a shared housing for a TPMS system as shown in Figures 1-2, and/or the rubber housing may be made of compliant materials other than rubber.

According to some embodiments of inventive concepts, a tire tread monitoring system (TTMS) may be mounted and/or encased inside a rubber housing (housing) or “boot.” The components encased in the housing may include the sensor, a battery and a PCB that includes

circuitry for sensor drive and sense, power management and RF communication. The PCB may also include temperature, humidity, and/or pressure sensors. In embodiments of Figures 12 and 13, the sensor electrodes may be encased flush with the surface of the housing such that the sensor electrodes directly contact the tire surface upon mounting. In other embodiments, the electrodes might be fully encased in the housing and not directly in contact with the tire surface. As also shown in Figure 12, the battery may be mounted directly above the sensor and below the PCB. In another embodiment, the battery may be mounted above the PCB or to the side depending on the battery size and shape. Figure 13 shows top and bottom views of the housing with the TPMS unit installed. Figure 14 shows a cross section of some embodiments that do not include a TPMS unit.

In some illustrated embodiments, the housing may also provide a housing for a tire pressure monitoring sensor (TPMS). In other embodiments, there may be no TPMS and the housing may house only the tire tread sensor elements. In Figure 13, the housing is shown to have a round shape but the shape may vary depending on sizes and shapes of tire tread sensor components.

According to some embodiments, the TTMS may measure tire tread and transmit tread data via Radio Frequency RF signaling outside the tire to an RF receiver. The RF receiver could be a component of a vehicle or a stand-alone mobile receiver. In some other embodiments, the TTMS may transmit data directly to the integrated TPMS system whereby the TPMS system collects the tread data, and retransmits the data to either a vehicle mounted receiver or mobile device, so that the TPMS system acts as a repeater. The TPMS system may simply act as a repeater or may collect the data, compile it with pressure and/or temperature data and transmit it to either a vehicle mounted receiver or mobile device.

Figure 12 is a cross sectional view of a sensor housing including a TPMS unit according to some embodiments. Figure 13 provides top and bottom views of the sensor housing of Figure 6 including a TPMS unit according to some embodiments. Figure 14 is a cross sectional view of a sensor housing that includes only the TTMS components (without TPMS components) according to some embodiments. Figure 15 is a cross sectional view of a sensor housing mounted inside a tire according to some embodiments.

The housing of Figure 12 may be formed by molding the housing material on/around the PCB, the battery, and/or the sensor (including sensor substrate and sensor electrodes). As

shown, the housing material may extend between portions of the PCB and battery, between portions of the battery and the sensor, and/or between portions of the PCB and sensor. According to some other embodiments, the PCB, the battery, and/or the sensor may be bonded before forming the housing. For example, a bonding material (different than the housing material) may be used to bond the PCB, the battery, and/or the sensor, and then a molding process (e.g., an injection molding process) may be used to form the housing (also referred to as a boot).

As shown, the housing may include a recess to accept a tire pressure monitoring system TPMS (or portions thereof) that may be provided after forming the housing. A wireless communicative coupling may be provided between the TPMS and the PCB, or an electrical coupling may be provided through the housing between the TPMS and the PCB. With an electrical coupling, for example, a wireless communication interface of TPMS may be used to transmit tread wear information generated by PCB, and/or power may be provided from TPMS to PCB so that a battery is not required in the housing. According to some other embodiments, TPMS, a wireless interface, and/or a power source may be provided separate from the housing, and an electrical coupling with the PCB may be provided through the housing.

The tire monitoring system of Figure 12 may thus include first and second sensor elements 1201a and 1201b, a printed circuit board PCB 1205, and a housing 1209. The circuit board 1205 may include control circuitry coupled with at least one of the first and second sensor elements 1201a and/or 1201b, where the control circuitry is configured to generate tire tread information based on an electrical response of at least one of the first and second sensor elements.

The housing 1209 may include a housing material that surrounds the printed circuit board 1205 in a direction parallel with respect to a surface of the circuit board. The housing material, for example, may be a compliant housing material, such as rubber, and the housing material may be molded around the printed circuit board 1205.

In addition, a power source 1211 (e.g., a battery) may be coupled with the printed circuit board, wherein the housing material surrounds the power source (e.g., battery) in the direction parallel with respect to the surface of the printed circuit board 1205. The power source may be between the printed circuit board 1205 and at least one of the first and second sensor elements 1201a and/or 1201b.

According to some embodiments, the housing material of housing 1209 may define a base adapted to provide an interface with an inside surface of a tire, and respective surfaces of the first and second sensor elements 1201a and 1201b may be exposed through the base of the housing material. According to some other embodiments, the housing material may define a base adapted to provide an interface with an inside surface of a tire, and respective surfaces of the first and second sensor elements 1201a and 1201b adjacent the base may be covered by the housing material.

A wireless communication interface may be provided on the printed circuit board 1205, and the wireless communication interface may be coupled with control circuitry on the printed circuit board 1205. The wireless communication interface may be configured to wirelessly transmit the tread wear information to a remote receiver. For example, at least a portion of the control circuitry and/or at least a portion of the wireless communication interface may be provided using one or more integrated circuit electronic devices mounted on the printed circuit board 1205.

A pressure sensor may also be coupled with the control circuitry, wherein the control circuitry is configured to generate tire pressure information based on an electrical response of the pressure sensor, and wherein the wireless communication interface is configured to wirelessly transmit the tire pressure information to the remote receiver. The pressure sensor, for example, may be provided as a MEMS based pressure sensor on printed circuit board 1205 and/or in TPMS unit 1215.

As shown, sensor elements 1201a and 1201b may be provided on a dielectric sensor substrate 1219, and the housing material and a material of the dielectric sensor substrate may be different. Moreover, at least a portion of the dielectric sensor substrate 1219 may be between the printed circuit board 1205 and at least one of the first and second sensor elements 1201a and/or 1201b. As discussed with respect to Figures 4 and 5, first and second leads may extend through the housing material, wherein the first lead provides electrical coupling between the first sensor element 1201a and the printed circuit board 1205, and wherein the second lead provides electrical coupling between the second sensor element 1201b and the printed circuit board 1205.

In the above-description of various embodiments of present inventive concepts, it is to be understood that the terminology used herein is for the purpose of describing particular embodiments only and is not intended to be limiting of present inventive concepts. Unless

otherwise defined, all terms (including technical and scientific terms) used herein have the same meaning as commonly understood by one of ordinary skill in the art to which present inventive concepts belong. It will be further understood that terms, such as those defined in commonly used dictionaries, should be interpreted as having a meaning that is consistent with their meaning in the context of this specification and the relevant art and will not be interpreted in an idealized or overly formal sense unless expressly so defined herein.

When an element is referred to as being "connected", "coupled", "responsive", or variants thereof to another element, it can be directly connected, coupled, or responsive to the other element or intervening elements may be present. In contrast, when an element is referred to as being "directly connected", "directly coupled", "directly responsive", or variants thereof to another element, there are no intervening elements present. Like numbers refer to like elements throughout. Furthermore, "coupled", "connected", "responsive", or variants thereof as used herein may include wirelessly coupled, connected, or responsive. As used herein, the singular forms "a", "an" and "the" are intended to include the plural forms as well, unless the context clearly indicates otherwise. Well-known functions or constructions may not be described in detail for brevity and/or clarity. The term "and/or" includes any and all combinations of one or more of the associated listed items.

It will be understood that although the terms first, second, third, etc. may be used herein to describe various elements/operations, these elements/operations should not be limited by these terms. These terms are only used to distinguish one element/operation from another element/operation. Thus, a first element/operation in some embodiments could be termed a second element/operation in other embodiments without departing from the teachings of present inventive concepts. The same reference numerals or the same reference designators denote the same or similar elements throughout the specification.

As used herein, the terms "comprise", "comprising", "comprises", "include", "including", "includes", "have", "has", "having", or variants thereof are open-ended, and include one or more stated features, integers, elements, steps, components or functions but does not preclude the presence or addition of one or more other features, integers, elements, steps, components, functions or groups thereof. Furthermore, as used herein, the common abbreviation "e.g.", which derives from the Latin phrase "exempli gratia," may be used to introduce or specify a general example or examples of a previously mentioned item, and is not intended to be limiting of such

item. The common abbreviation "i.e.", which derives from the Latin phrase "id est," may be used to specify a particular item from a more general recitation.

The dimensions of elements in the drawings may be exaggerated for the sake of clarity. Further, it will be understood that when an element is referred to as being "on" another element, the element may be directly on the other element, or there may be an intervening element therebetween. Moreover, terms such as "top," "bottom," "upper," "lower," "above," "below," and the like are used herein to describe the relative positions of elements or features as shown in the figures. For example, when an upper part of a drawing is referred to as a "top" and a lower part of a drawing is referred to as a "bottom" for the sake of convenience, in practice, the "top" may also be called a "bottom" and the "bottom" may also be a "top" without departing from the teachings of the inventive concept (e.g., if the structure is rotate 180 degrees relative to the orientation of the figure).

Example embodiments are described herein with reference to block diagrams and/or flowchart illustrations of computer-implemented methods, apparatus (systems and/or devices) and/or computer program products. It is understood that a block of the block diagrams and/or flowchart illustrations, and combinations of blocks in the block diagrams and/or flowchart illustrations, can be implemented by computer program instructions that are performed by one or more computer circuits. These computer program instructions may be provided to a processor circuit of a general purpose computer circuit, special purpose computer circuit, and/or other programmable data processing circuit to produce a machine, such that the instructions, which execute via the processor of the computer and/or other programmable data processing apparatus, transform and control transistors, values stored in memory locations, and other hardware components within such circuitry to implement the functions/acts specified in the block diagrams and/or flowchart block or blocks, and thereby create means (functionality) and/or structure for implementing the functions/acts specified in the block diagrams and/or flowchart block(s).

These computer program instructions may also be stored in a tangible computer-readable medium that can direct a computer or other programmable data processing apparatus to function in a particular manner, such that the instructions stored in the computer-readable medium produce an article of manufacture including instructions which implement the functions/acts specified in the block diagrams and/or flowchart block or blocks. Accordingly, embodiments of present inventive concepts may be embodied in hardware and/or in software (including

firmware, resident software, micro-code, etc.) that runs on a processor (also referred to as a controller) such as a digital signal processor, which may collectively be referred to as "circuitry," "a module" or variants thereof.

It should also be noted that in some alternate implementations, the functions/acts noted in the blocks may occur out of the order noted in the flowcharts. For example, two blocks shown in succession may in fact be executed substantially concurrently or the blocks may sometimes be executed in the reverse order, depending upon the functionality/acts involved. Moreover, the functionality of a given block of the flowcharts and/or block diagrams may be separated into multiple blocks and/or the functionality of two or more blocks of the flowcharts and/or block diagrams may be at least partially integrated. Finally, other blocks may be added/inserted between the blocks that are illustrated, and/or blocks/operations may be omitted without departing from the scope of inventive concepts. Moreover, although some of the diagrams include arrows on communication paths to show a primary direction of communication, it is to be understood that communication may occur in the opposite direction to the depicted arrows.

Many variations and modifications can be made to the embodiments without substantially departing from the principles of the present inventive concepts. All such variations and modifications are intended to be included herein within the scope of present inventive concepts. Accordingly, the above disclosed subject matter is to be considered illustrative, and not restrictive, and the examples of embodiments are intended to cover all such modifications, enhancements, and other embodiments, which fall within the spirit and scope of present inventive concepts. Thus, to the maximum extent allowed by law, the scope of present inventive concepts are to be determined by the broadest permissible interpretation of the present disclosure including the following claims and their equivalents, and shall not be restricted or limited by the foregoing detailed description.

CLAIMS:

1. A tire monitoring system comprising:
first and second sensor elements;
a circuit board including control circuitry coupled with at least one of the first and second sensor elements, wherein the control circuitry is configured to generate tire tread information based on an electrical response of at least one of the first and second sensor elements; and
a housing comprising a housing material that surrounds the circuit board in a direction parallel with respect to a surface of the circuit board.
2. The tire monitoring system of Claim 1, wherein the housing material comprises a compliant housing material.
3. The tire monitoring system of Claim 2, wherein the housing materials comprises rubber.
4. The tire monitoring system of any of Claims 1-3, wherein the housing material is a molded housing material.
5. The tire monitoring system of Claim 4, wherein the housing material is molded around the circuit board.
6. The tire monitoring system of any of Claims 1-5 further comprising:
a power source electrically coupled with the printed circuit board, wherein the housing material surrounds the power source in the direction parallel with respect to the surface of the circuit board.
7. The tire monitoring system of Claim 6, wherein the power source is between the circuit board and at least one of the first and second sensor elements.

8. The tire monitoring system of any of Claims 6-7, wherein the power source comprises a battery.

9. The tire monitoring system of any of Claims 1-8, wherein the housing material defines a base adapted to provide an interface with an inside surface of a tire, and wherein respective surfaces of the first and second sensor elements are exposed through the base of the housing material.

10. The tire monitoring system of any of Claims 1-8, wherein the housing material defines a base adapted to provide an interface with an inside surface of a tire, and wherein respective surfaces of the first and second sensor elements adjacent the base are covered by the housing material.

11. The tire monitoring system of any of Claims 1-10 further comprising:
a wireless communication interface coupled with the control circuitry, wherein the wireless communication interface is configured to wirelessly transmit the tread wear information to a remote receiver.

12. The tire monitoring system of Claim 11, wherein at a least portion of the control circuitry and/or at least a portion of the wireless communication interface comprise an integrated circuit electronic device mounted on the circuit board.

13. The tire monitoring system of any of Claims 11-12 further comprising:
a pressure sensor coupled with the control circuitry, wherein the control circuitry is configured to generate tire pressure information based on an electrical response of the pressure sensor, and wherein the wireless communication interface is configured to wirelessly transmit the tire pressure information to the remote receiver.

14. The tire monitoring system of any of Claims 1-13 further comprising:

a dielectric sensor substrate, wherein the first and second sensor elements are provided on the dielectric sensor substrate, and wherein the housing material and a material of the dielectric sensor substrate are different.

15. The tire monitoring system of Claim 14, wherein at least a portion of the dielectric sensor substrate is between the circuit board and at least one of the first and second sensor elements.

16. The tire monitoring system of any of Claims 14-15 further comprising:
first and second leads extending through the housing material, wherein the first lead provides electrical coupling between the first sensor element and the circuit board, and wherein the second lead provides electrical coupling between the second sensor element and the circuit board.

17. The tire monitoring system of any of Claims 1-12, wherein an electrical coupling with the circuit board is provided through the housing material, the tire monitoring system further comprising:

a pressure sensor and/or a tire pressure monitoring system electrically coupled with the circuit board through the electrical coupling.

18. The tire monitoring system of any of Claims 1-10, wherein an electrical coupling with the circuit board is provided through the housing material, the tire monitoring system further comprising:

a wireless communication interface coupled with the circuit board through the electrical coupling, wherein the wireless communication interface is configured to wirelessly transmit the tread wear information to a remote receiver.

19. The tire monitoring system of any of Claims 1-5, wherein an electrical coupling with the circuit board is provided through the housing material, the tire monitoring system further comprising:

a power source electrically coupled with the circuit board through the electrical coupling.

20. A method providing a tire monitoring system, the method comprising:
providing first and second sensor elements;
providing a circuit board including control circuitry coupled with at least one of the first and second sensor elements, wherein the control circuitry is configured to generate tire tread information based on an electrical response of at least one of the first and second sensor elements; and
forming a housing on the circuit board using a housing material that surrounds the circuit board in a direction parallel with respect to a surface of the circuit board.
21. The method of Claim 20, wherein the housing material comprises a compliant housing material.
22. The method of Claim 21, wherein the housing materials comprises rubber.
23. The method of any of Claims 20-22, wherein forming the housing comprises molding the housing material on and/or around the first and second sensor elements and the circuit board.
24. The method of Claim 23, wherein molding comprises injection molding.
25. The method of any of Claims 20-24 further comprising:
providing a power source electrically coupled with the printed circuit board;
wherein forming the housing comprises forming the housing so that the housing material surrounds the power source in the direction parallel with respect to the surface of the circuit board.
26. The method of Claim 25, wherein the power source is between the circuit board and at least one of the first and second sensor elements.
27. The method of any of Claims 25-26, wherein the power source comprises a battery.

28. The method of any of Claims 20-27, wherein forming the housing comprises forming the housing so that the housing material defines a base adapted to provide an interface with an inside surface of a tire and so that respective surfaces of the first and second sensor elements are exposed through the base of the housing material.

29. The method of any of Claims 20-27, wherein forming the housing comprises forming the housing so that the housing material defines a base adapted to provide an interface with an inside surface of a tire and so that respective surfaces of the first and second sensor elements adjacent the base are covered by the housing material.

30. The method of any of Claims 20-29 further comprising:
providing a wireless communication interface coupled with the control circuitry, wherein the wireless communication interface is configured to wirelessly transmit the tread wear information to a remote receiver.

31. The method of Claim 30, wherein at least a portion of the control circuitry and/or at least a portion of the wireless communication interface comprise an integrated circuit electronic device mounted on the circuit board.

32. The method of any of Claims 30-31 further comprising:
providing a pressure sensor coupled with the control circuitry, wherein the control circuitry is configured to generate tire pressure information based on an electrical response of the pressure sensor, and wherein the wireless communication interface is configured to wirelessly transmit the tire pressure information to the remote receiver.

33. The method of any of Claims 20-32, wherein providing the first and second sensor elements comprises providing the first and second sensor elements on a dielectric sensor substrate, and wherein the housing material and a material of the dielectric sensor substrate are different.

34. The method of Claim 33, wherein at least a portion of the dielectric sensor substrate is between the circuit board and at least one of the first and second sensor elements.

35. The method of any of Claims 33-34 further comprising:
providing first and second leads, wherein the first lead provides electrical coupling between the first sensor element and the circuit board, wherein the second lead provides electrical coupling between the second sensor element and the circuit board, and wherein forming the housing comprises forming the housing so that the first and second leads extend through the housing material.

36. The method of any of Claims 20-31, wherein an electrical coupling with the circuit board is provided through the housing material, the method further comprising:
after forming the housing, providing a pressure sensor and/or a tire pressure monitoring system electrically coupled with the circuit board through the electrical coupling.

37. The method of any of Claims 20-28, wherein an electrical coupling with the circuit board is provided through the housing material, the method further comprising:
after forming the housing, providing a wireless communication interface coupled with the circuit board through the electrical coupling, wherein the wireless communication interface is configured to wirelessly transmit the tread wear information to a remote receiver.

38. The method of any of Claims 20-24, wherein an electrical coupling with the circuit board is provided through the housing material, the method further comprising:
after forming the housing, providing a power source electrically coupled with the circuit board through the electrical coupling.

39. The method of any of Claims 20-38 further comprising:
bonding the first and second sensor elements and the circuit board using a bonding material before forming the housing.

40. The method of Claim 39, wherein the housing material and the bonding material are different.

Lid

Figure 1

Carrier

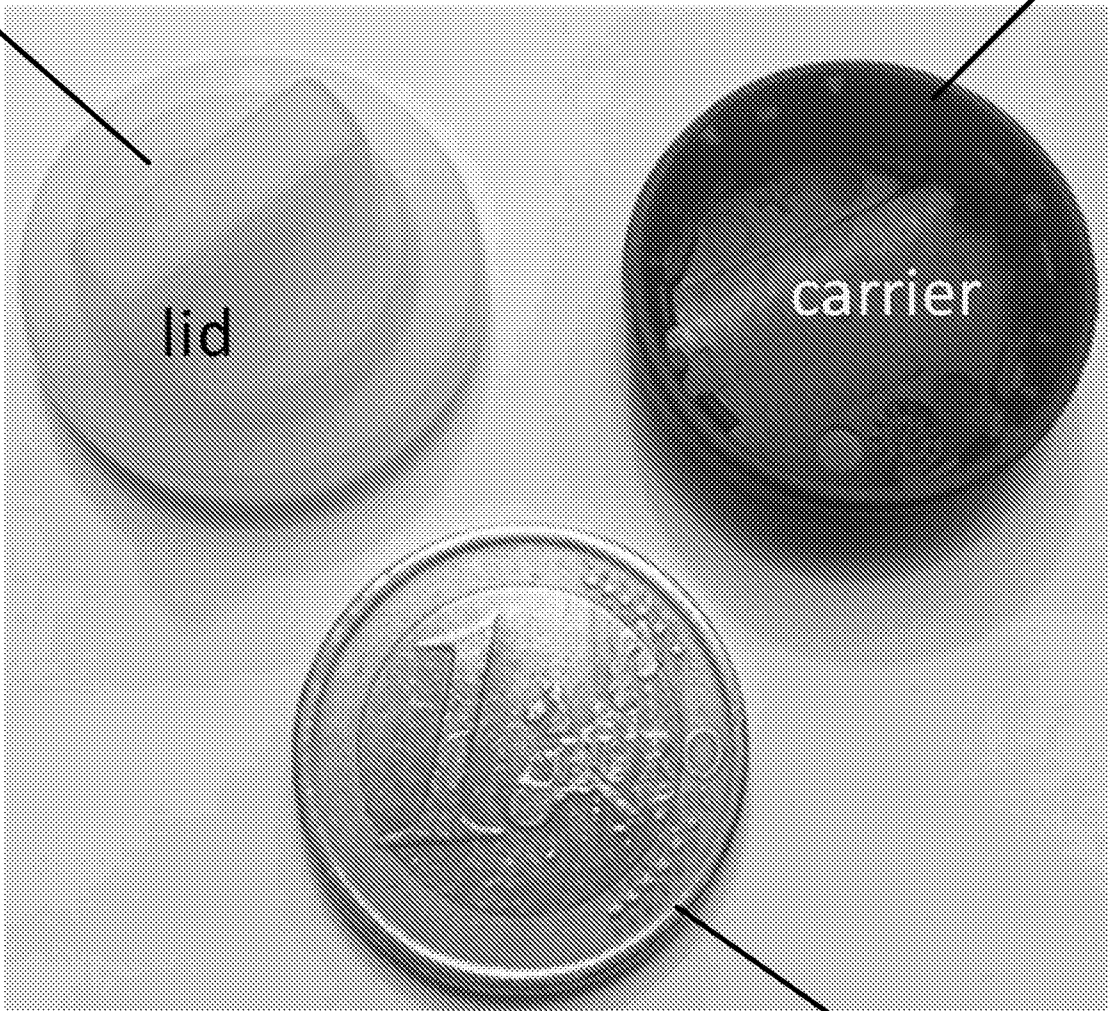

1 Euro Coin For Scale

Figure 2

Rubber mount

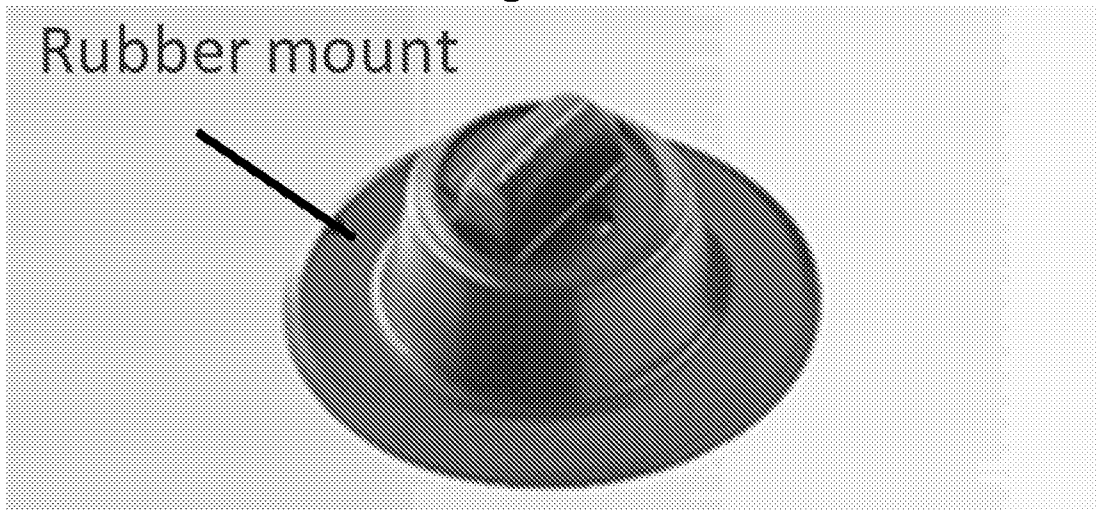

Figure 3

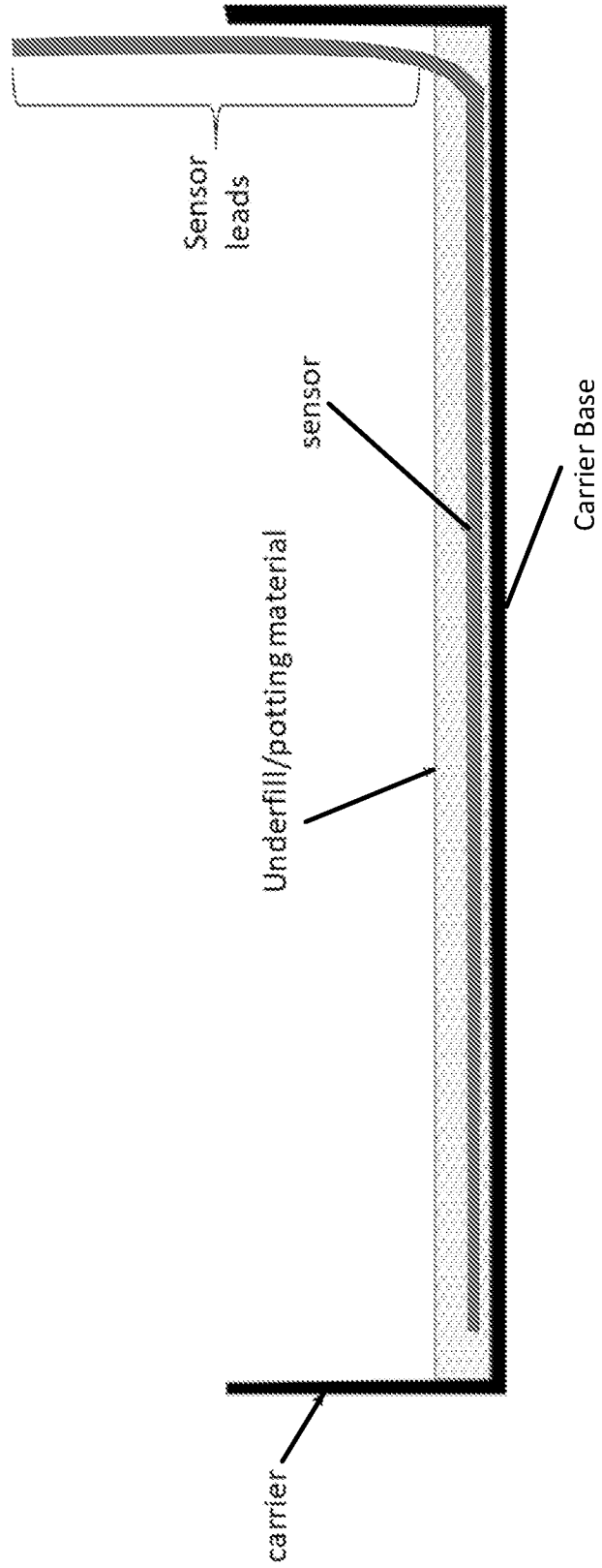

Figure 4

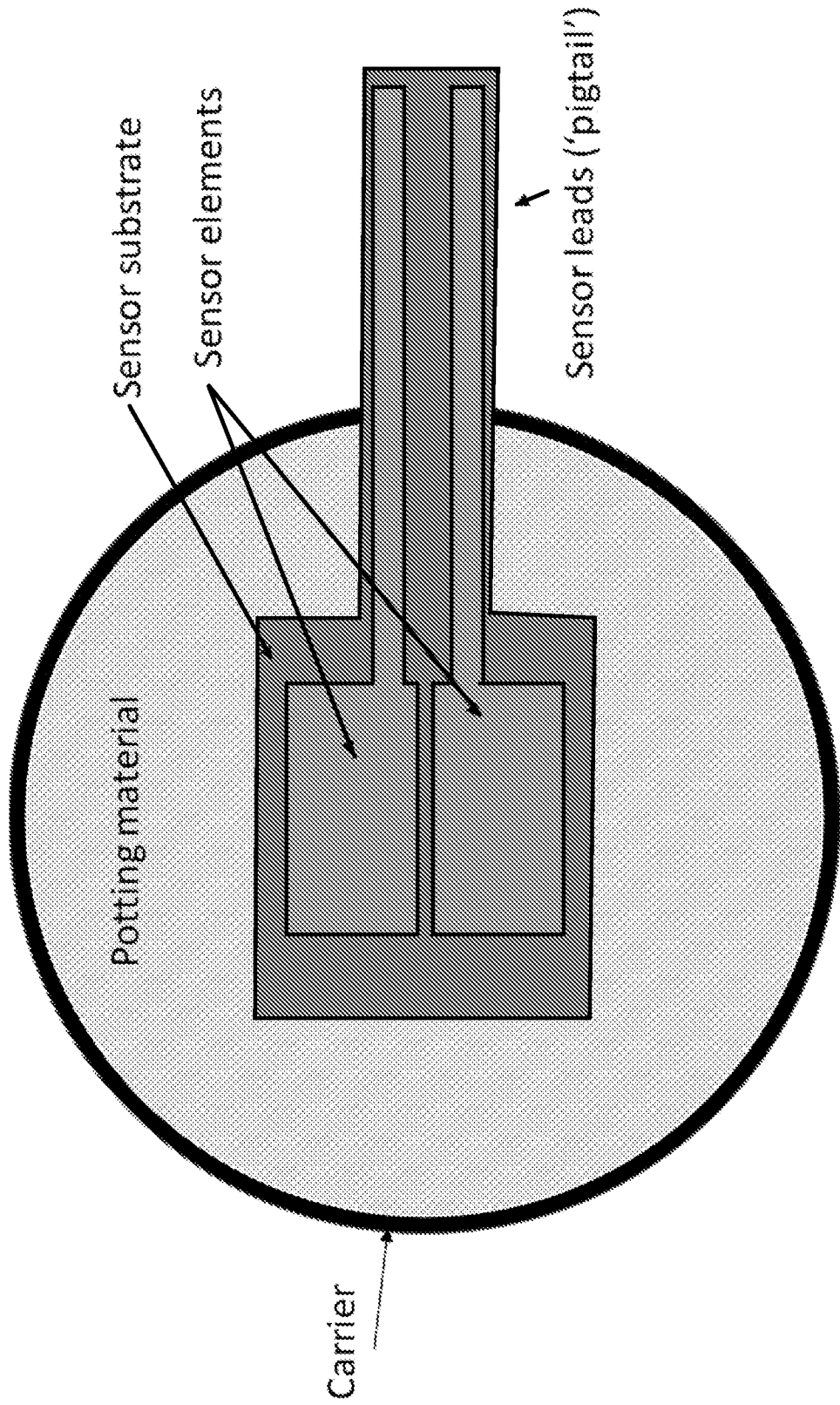

Figure 5

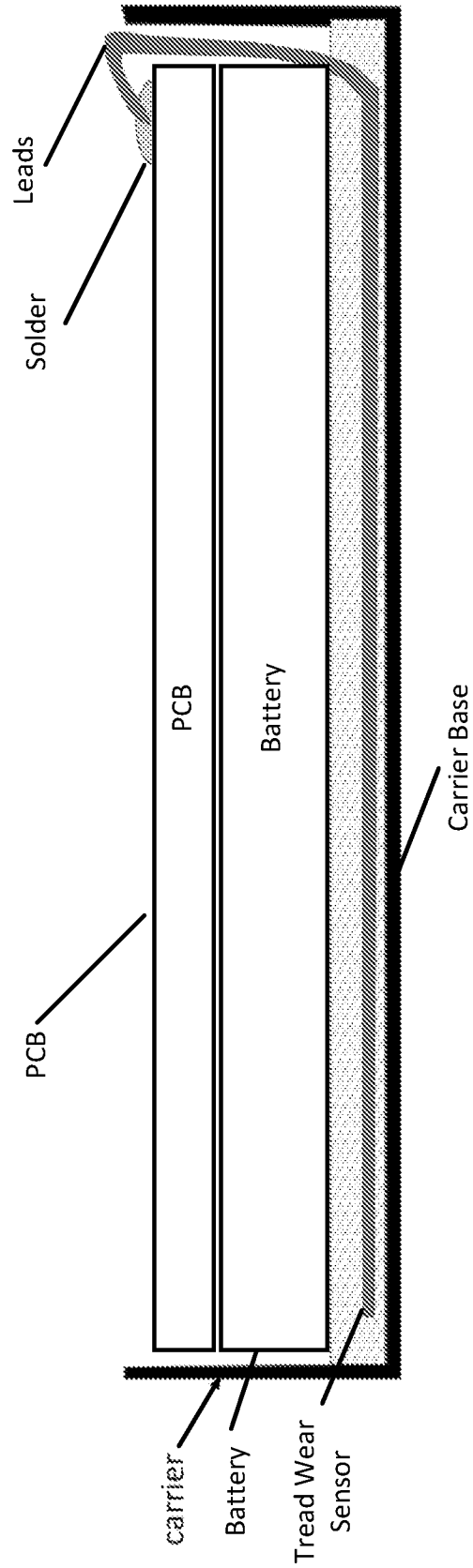

Figure 6

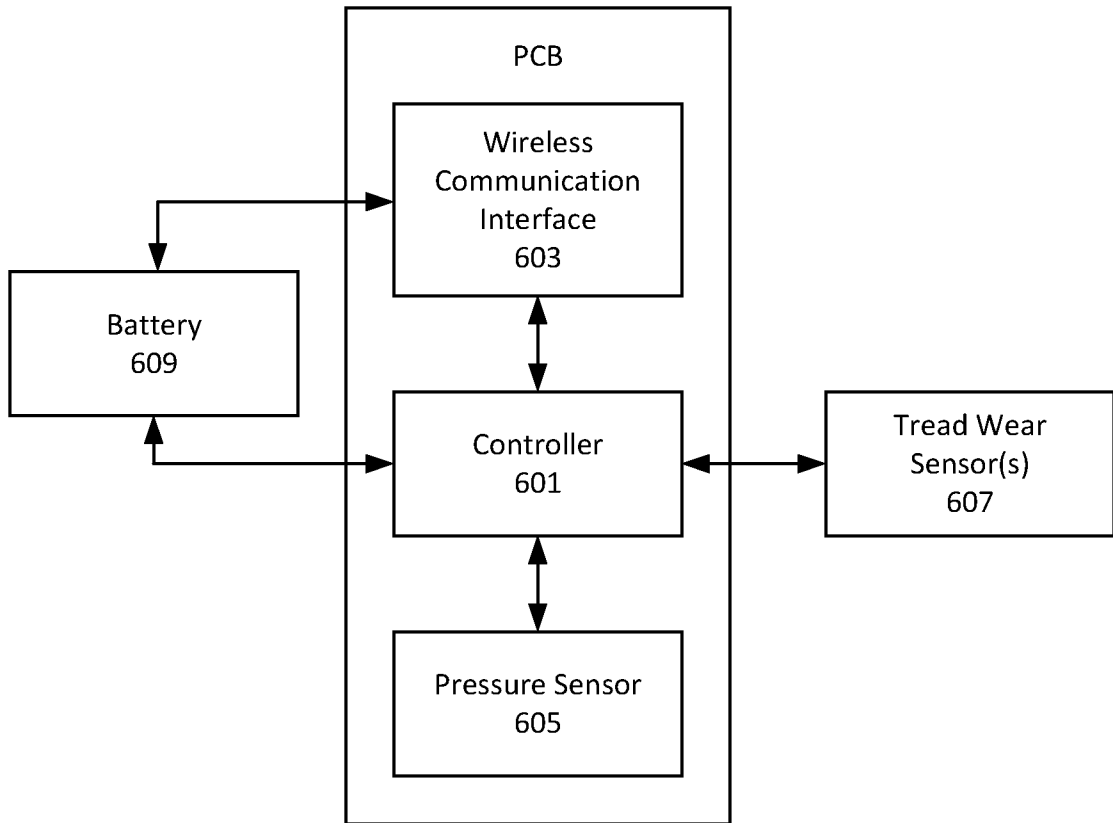

Figure 7A

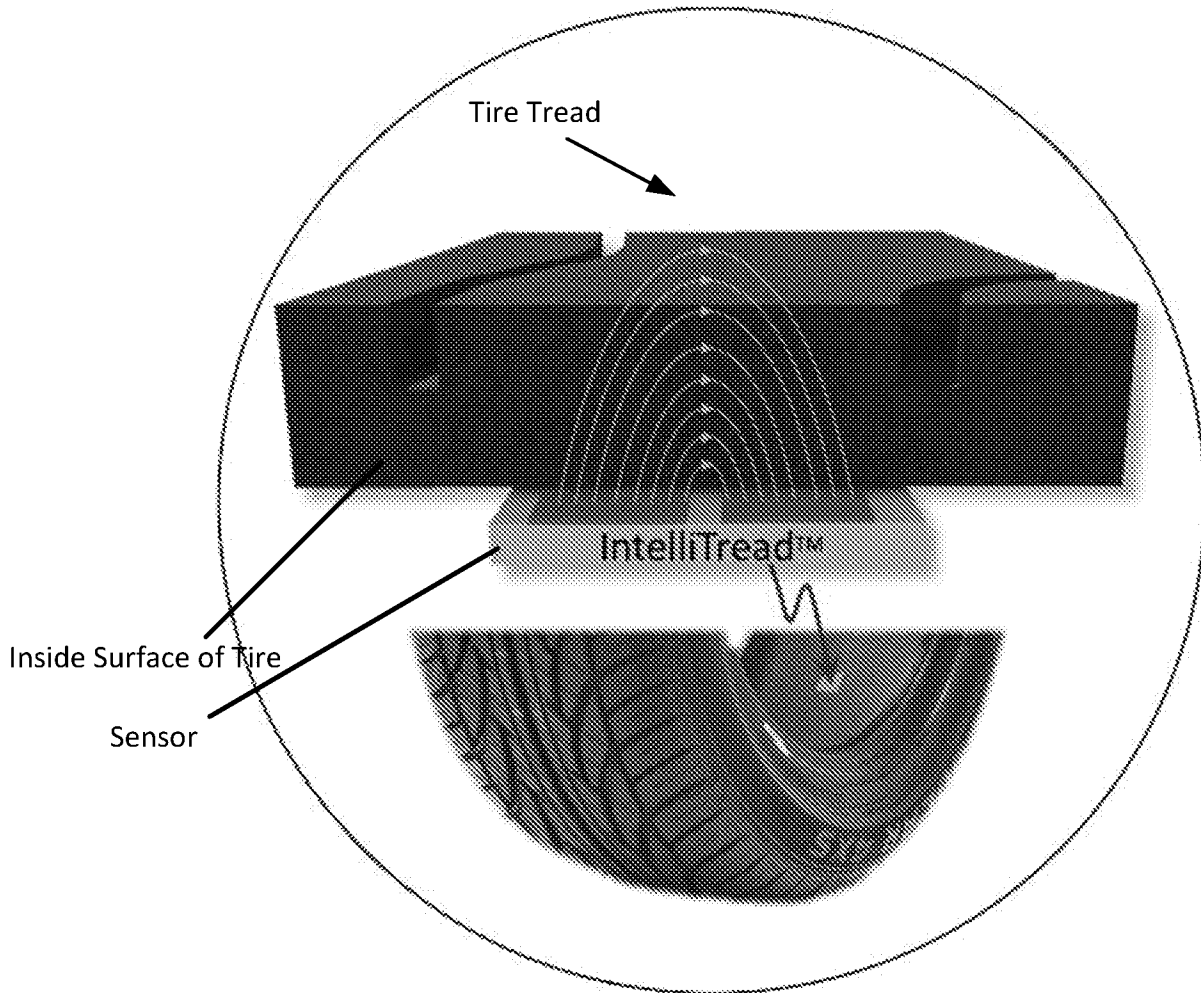

Figure 7B

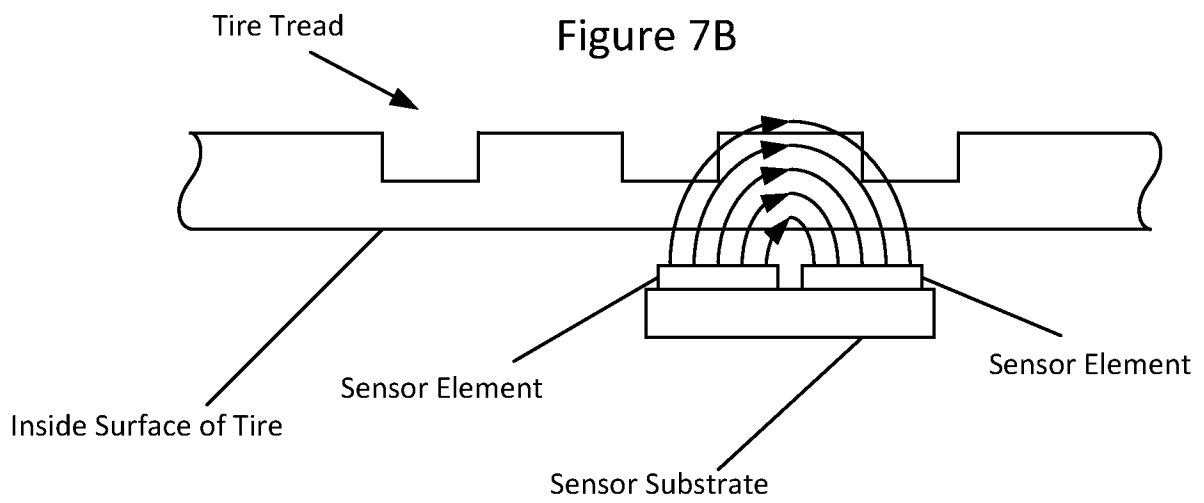

Figure 8
Custom PC Board

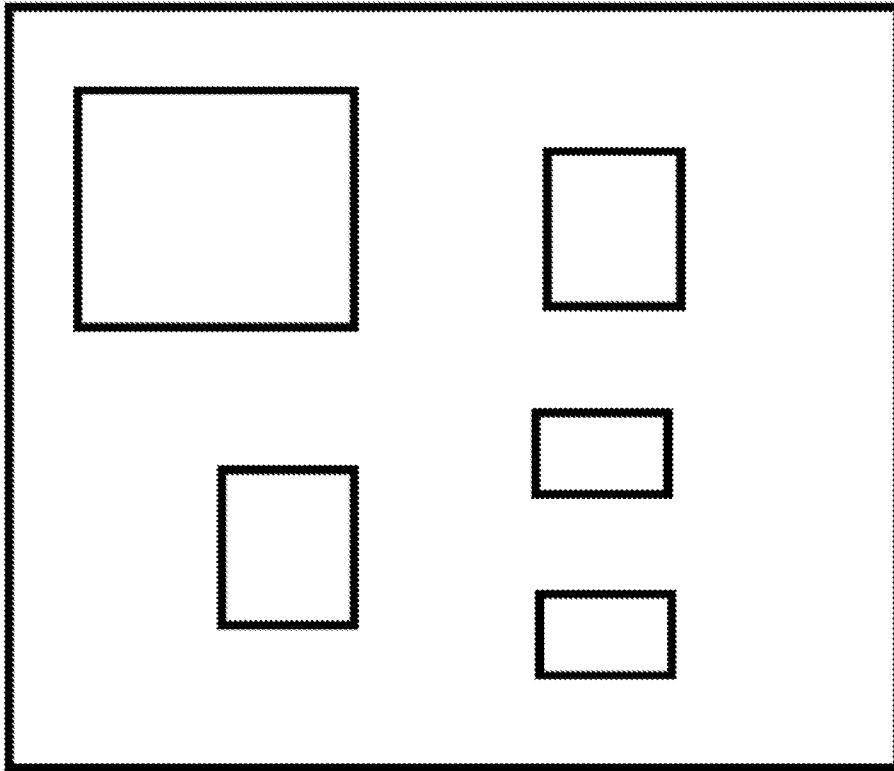

Figure 9
Sensor

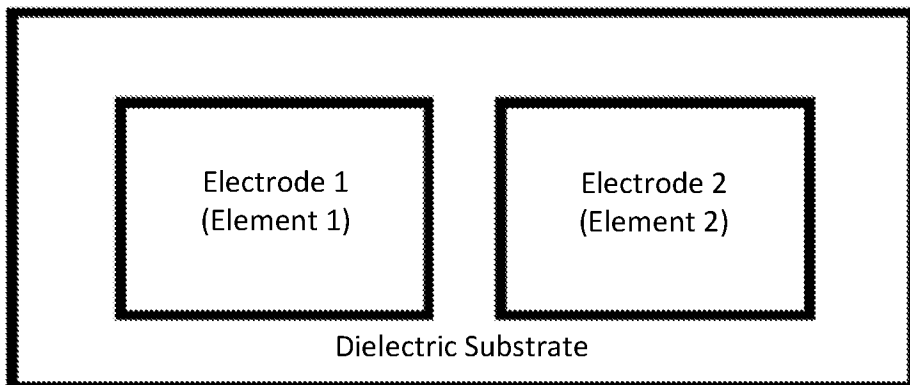

Figure 10
Battery

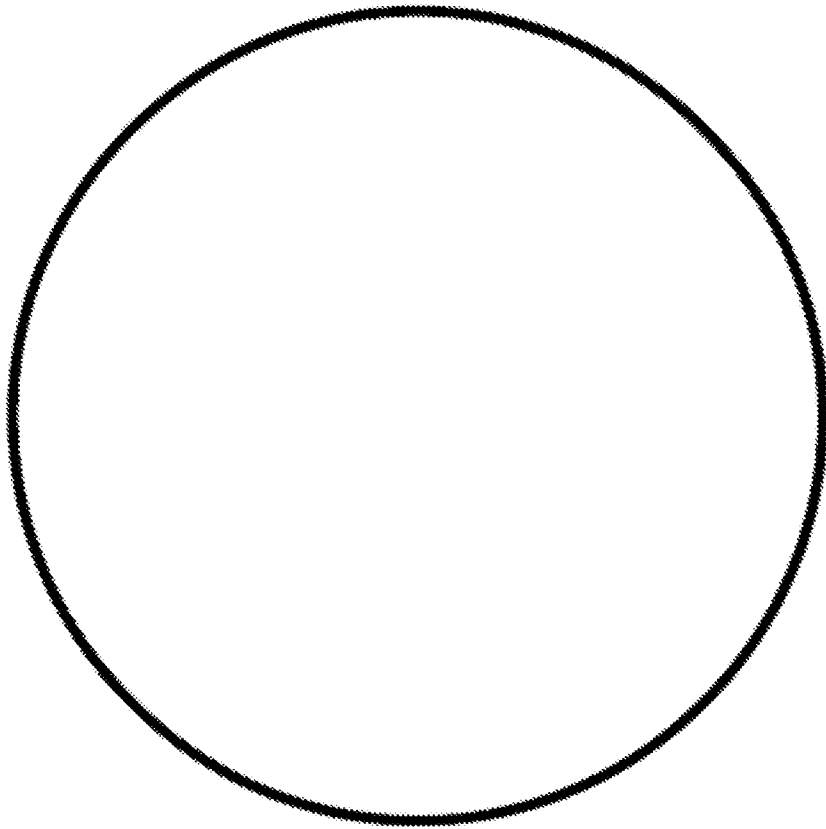

Figure 11
Housing

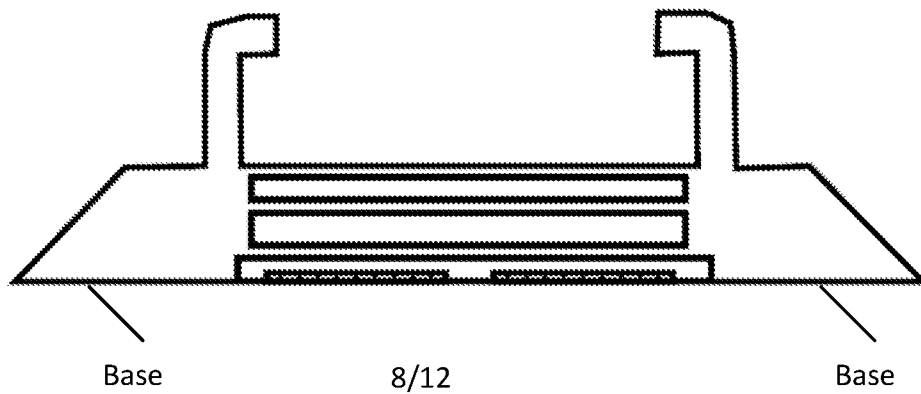

Figure 12
Cross sectional view of sensor housing including TPMS unit

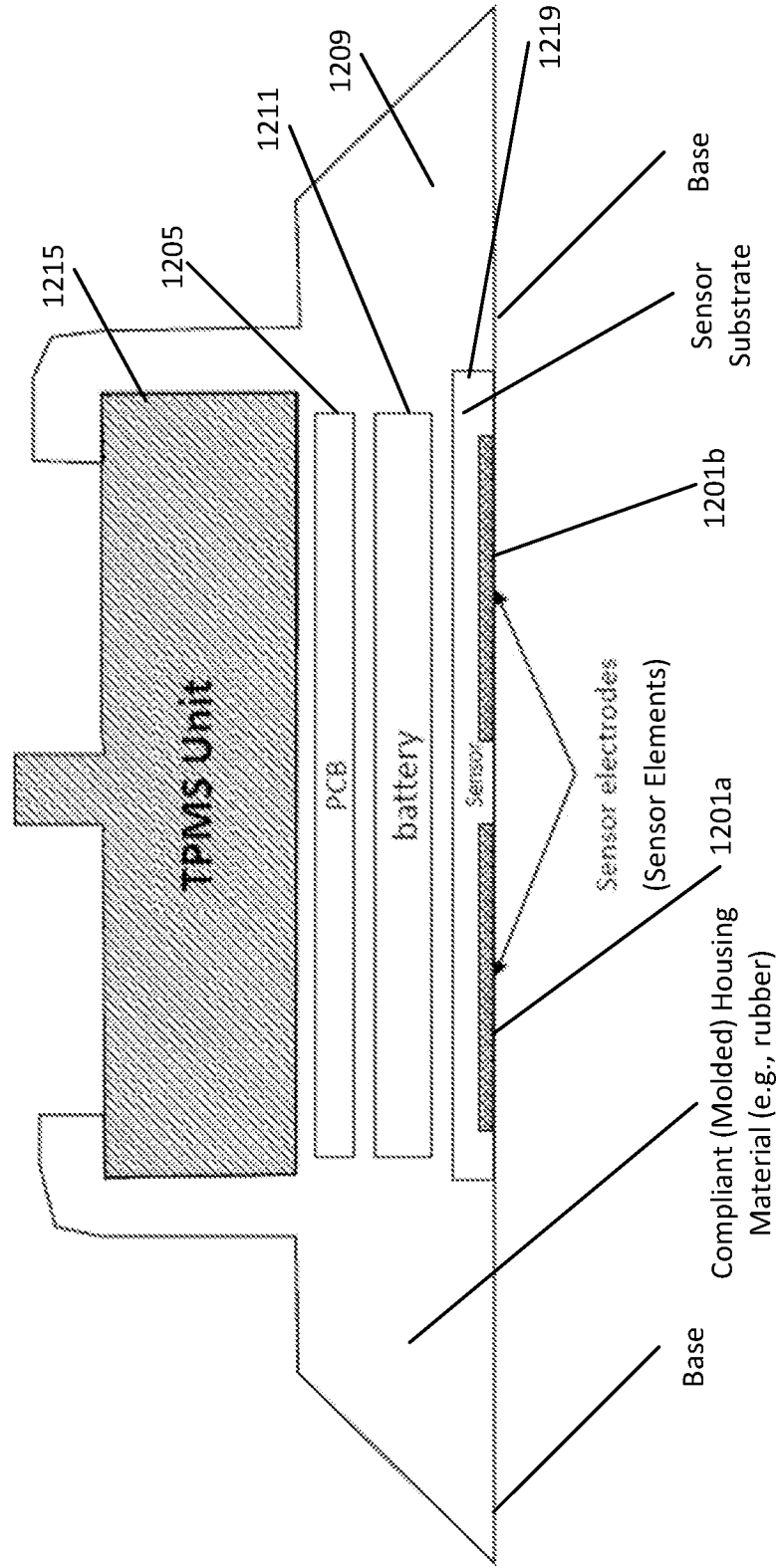

Figure 13
Top and Bottom Views of the Sensor Housing of Figure 12

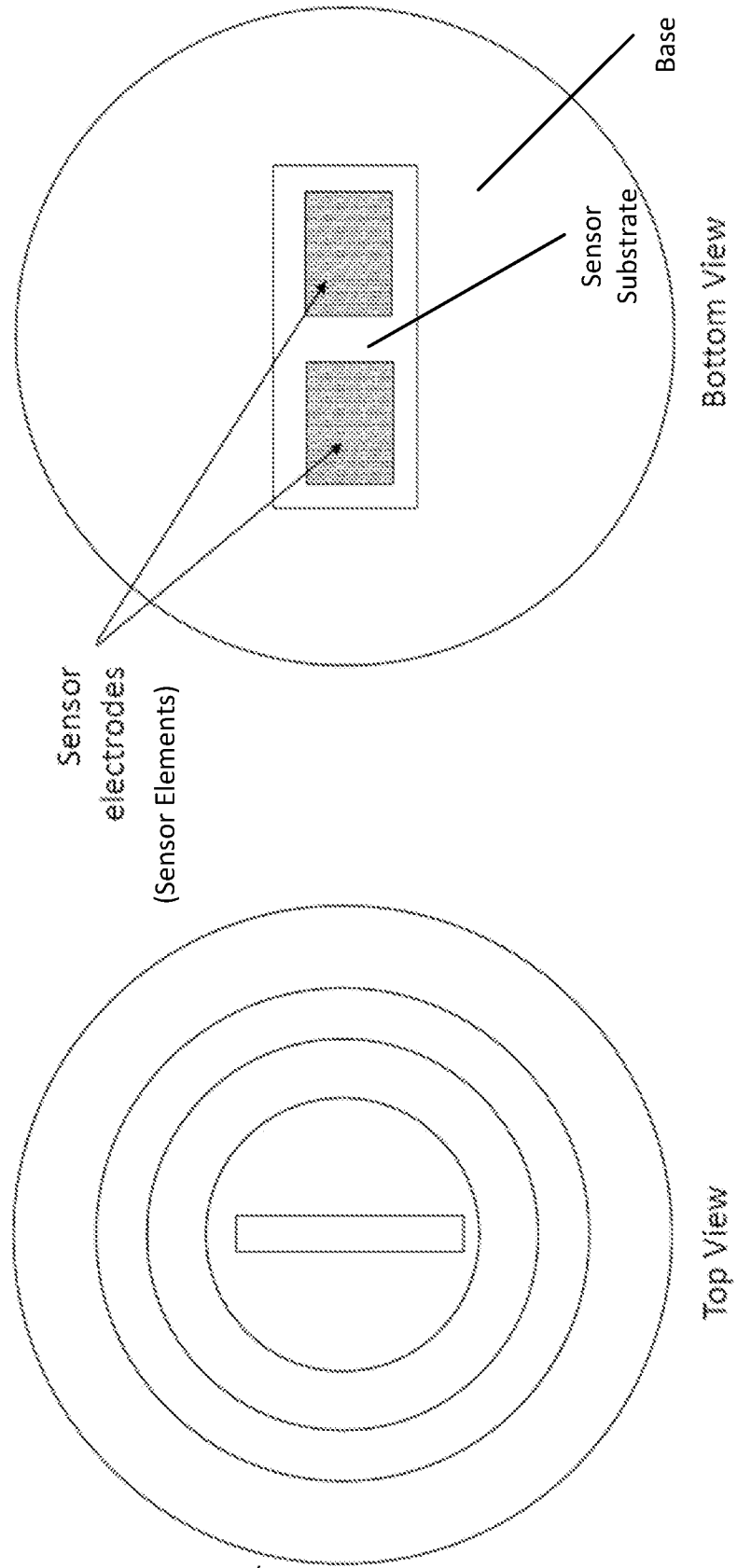

Figure 14
Cross sectional view of sensor housing that includes only the TTMS components

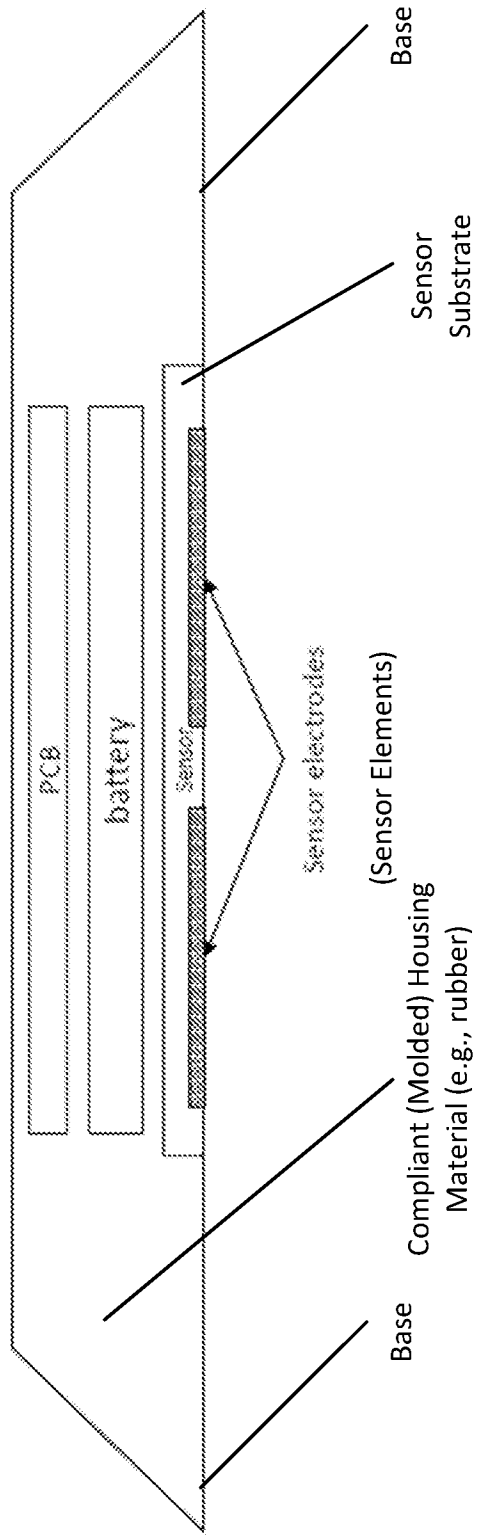
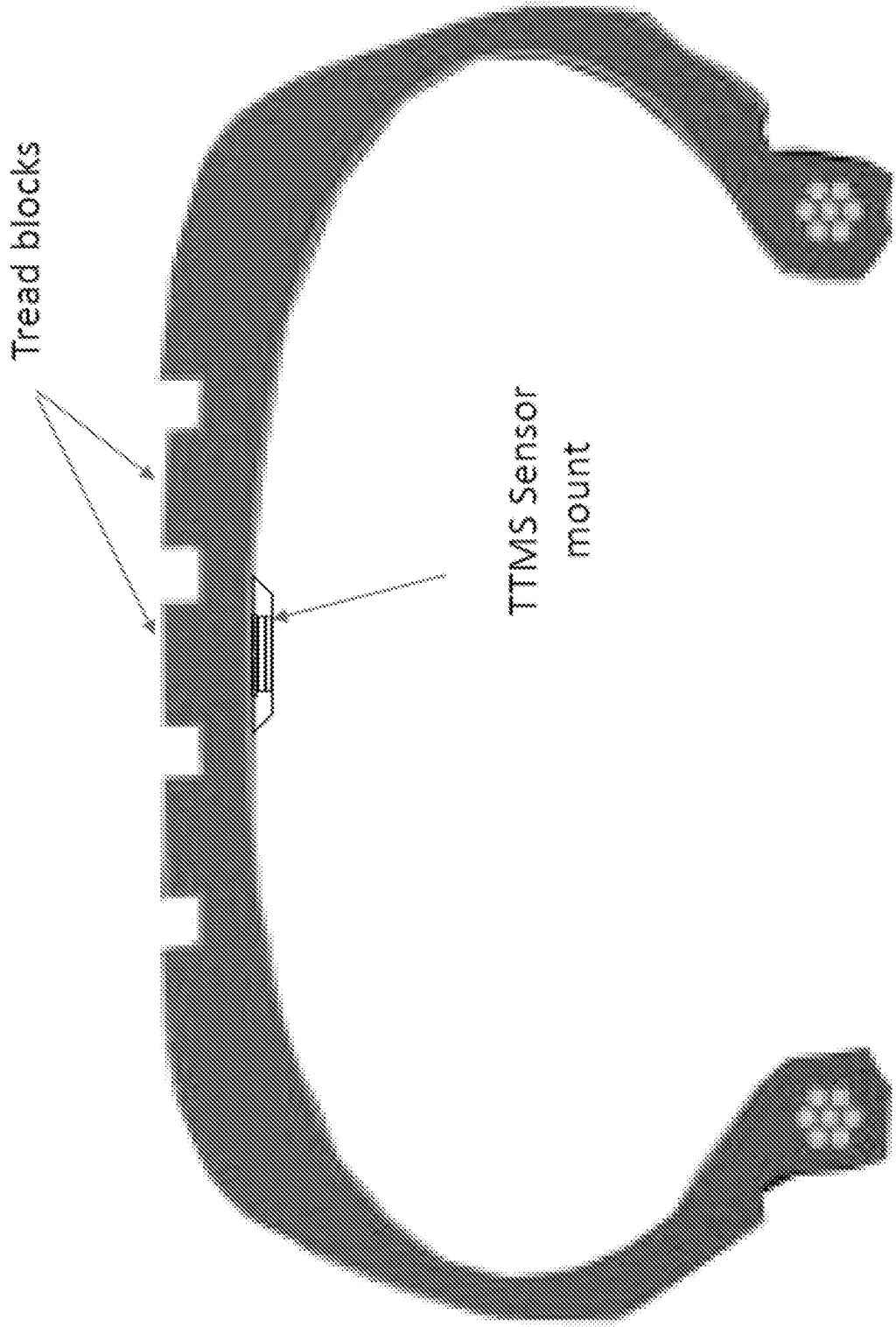

Figure 15
Cross sectional view of sensor housing mounted inside a tire



INTERNATIONAL SEARCH REPORT

International application No.
PCT/US2019/038872

A. CLASSIFICATION OF SUBJECT MATTER
IPC(8) - B60C 11/24; G01D 11/24 (2019.01)
CPC - B60C 11/243; B60C 11/246 (2019.08)

According to International Patent Classification (IPC) or to both national classification and IPC

B. FIELDS SEARCHED

Minimum documentation searched (classification system followed by classification symbols)
See Search History document

Documentation searched other than minimum documentation to the extent that such documents are included in the fields searched
USPC - 340/442; 340/443; 340/425.5; 340/426.33 (keyword delimited)

Electronic data base consulted during the international search (name of data base and, where practicable, search terms used)
See Search History document

C. DOCUMENTS CONSIDERED TO BE RELEVANT

Category*	Citation of document, with indication, where appropriate, of the relevant passages	Relevant to claim No.
X	US 6,087,930 A (KULKA et al) 11 July 2000 (11.07.2000) entire document	1-5, 20-23
Y		24
Y	US 2009/0261962 A1 (BUCK et al) 22 October 2009 (22.10.2009) entire document	24
A	US 2016/0025585 A1 (DAMMEN et al) 28 January 2016 (28.01.2016) entire document	1-5, 20-24
A	US 8,047,068 B2 (HAMM et al) 01 November 2011 (01.11.2011) entire document	1-5, 20-24
A	US 2017/0174014 A1 (SCHRADER ELECTRONICS LIMITED) 22 June 2017 (22.06.2017) entire document	1-5, 20-24
A	US 7,775,115 B2 (THEUSS et al) 17 August 2010 (17.08.2010) entire document	1-5, 20-24

Further documents are listed in the continuation of Box C. See patent family annex.

* Special categories of cited documents:

"A" document defining the general state of the art which is not considered to be of particular relevance	"T" later document published after the international filing date or priority date and not in conflict with the application but cited to understand the principle or theory underlying the invention
"E" earlier application or patent but published on or after the international filing date	"X" document of particular relevance; the claimed invention cannot be considered novel or cannot be considered to involve an inventive step when the document is taken alone
"L" document which may throw doubts on priority claim(s) or which is cited to establish the publication date of another citation or other special reason (as specified)	"Y" document of particular relevance; the claimed invention cannot be considered to involve an inventive step when the document is combined with one or more other such documents, such combination being obvious to a person skilled in the art
"O" document referring to an oral disclosure, use, exhibition or other means	"&" document member of the same patent family
"P" document published prior to the international filing date but later than the priority date claimed	

Date of the actual completion of the international search
14 August 2019

Date of mailing of the international search report
17 SEP 2019

Name and mailing address of the ISA/US
Mail Stop PCT, Attn: ISA/US, Commissioner for Patents
P.O. Box 1450, Alexandria, VA 22313-1450
Facsimile No. 571-273-8300

Authorized officer
Blaine R. Copenheaver
PCT Helpdesk: 571-272-4300
PCT OSP: 571-272-7774

INTERNATIONAL SEARCH REPORT

International application No.

PCT/US2019/038872

Box No. II Observations where certain claims were found unsearchable (Continuation of item 2 of first sheet)

This international search report has not been established in respect of certain claims under Article 17(2)(a) for the following reasons:

1. Claims Nos.:
because they relate to subject matter not required to be searched by this Authority, namely:

2. Claims Nos.:
because they relate to parts of the international application that do not comply with the prescribed requirements to such an extent that no meaningful international search can be carried out, specifically:

3. Claims Nos.: 6-19, 25-40
because they are dependent claims and are not drafted in accordance with the second and third sentences of Rule 6.4(a).

Box No. III Observations where unity of invention is lacking (Continuation of item 3 of first sheet)

This International Searching Authority found multiple inventions in this international application, as follows:

1. As all required additional search fees were timely paid by the applicant, this international search report covers all searchable claims.
2. As all searchable claims could be searched without effort justifying additional fees, this Authority did not invite payment of additional fees.
3. As only some of the required additional search fees were timely paid by the applicant, this international search report covers only those claims for which fees were paid, specifically claims Nos.:

4. No required additional search fees were timely paid by the applicant. Consequently, this international search report is restricted to the invention first mentioned in the claims; it is covered by claims Nos.:

Remark on Protest

- The additional search fees were accompanied by the applicant's protest and, where applicable, the payment of a protest fee.
- The additional search fees were accompanied by the applicant's protest but the applicable protest fee was not paid within the time limit specified in the invitation.
- No protest accompanied the payment of additional search fees.