



US 20050148410A1

(19) **United States**

(12) **Patent Application Publication**

**DeLisle et al.**

(10) **Pub. No.: US 2005/0148410 A1**

(43) **Pub. Date: Jul. 7, 2005**

(54) **GOLF TEE WITH SUPPORT PRONGS**

**Publication Classification**

(51) **Int. Cl.<sup>7</sup> ..... A63B 57/00**

(52) **U.S. Cl. .... 473/387**

(76) **Inventors: Stephen P. DeLisle**, Carolina Shores, NC (US); **Benjamin J. Maloy**, Carolina Shores, NC (US)

(57) **ABSTRACT**

Correspondence Address:

**MYERS BIGEL SIBLEY & SAJOVEC**  
**PO BOX 37428**  
**RALEIGH, NC 27627 (US)**

A golf tee includes: an elongate shaft having opposed upper and lower ends, the lower end configured to be inserted into an underlying surface; and a support cup that is configured to support a golf ball from beneath and that merges with the shaft. The support cup has a base portion and further includes at least three arcuate support prongs projecting upwardly from the base portion. The support prongs define a discontinuous annulus about the periphery of the support cup.

(21) **Appl. No.: 10/750,710**

(22) **Filed: Jan. 2, 2004**

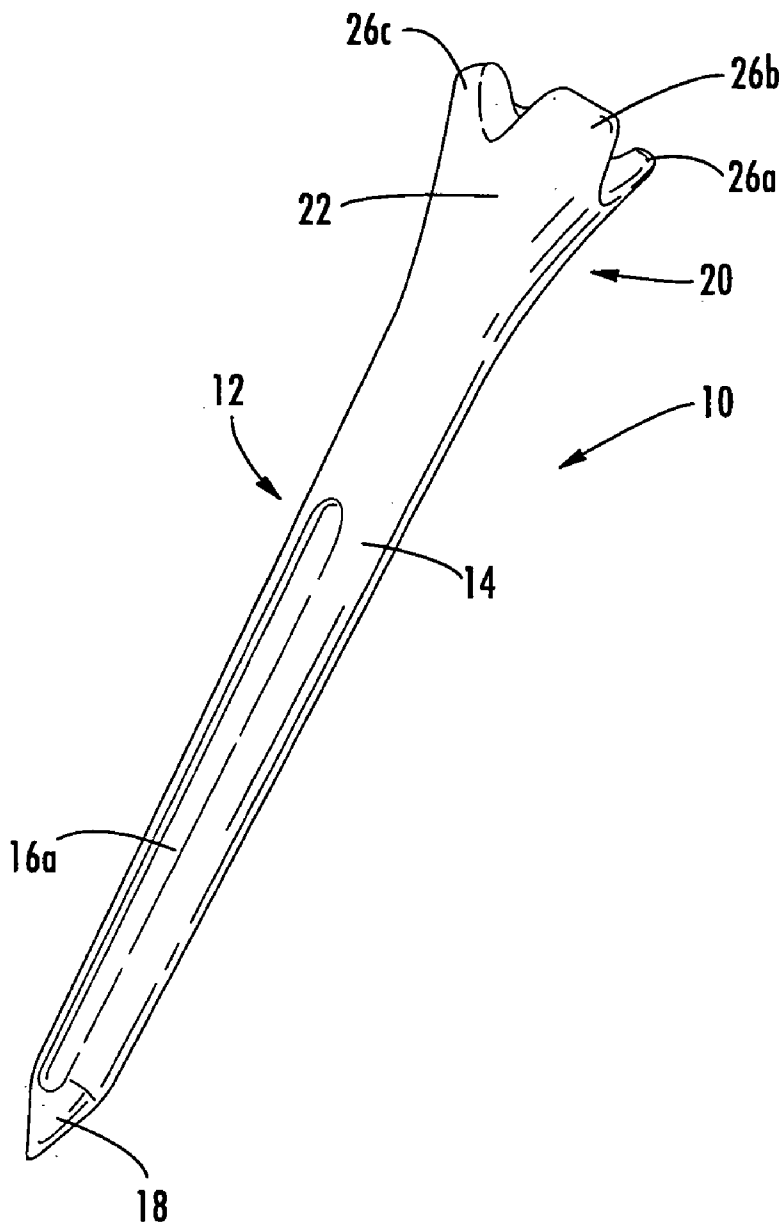

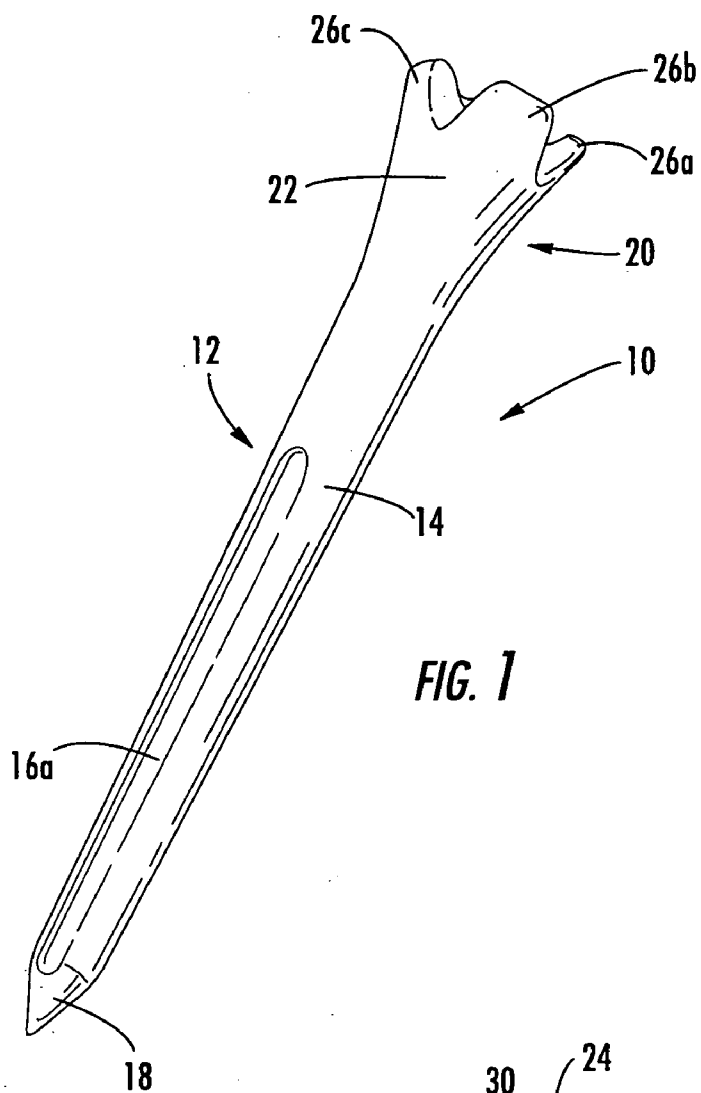

FIG. 1

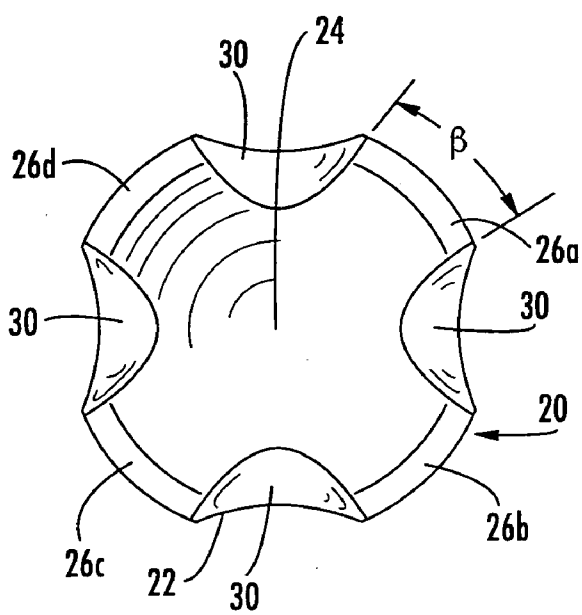

FIG. 2

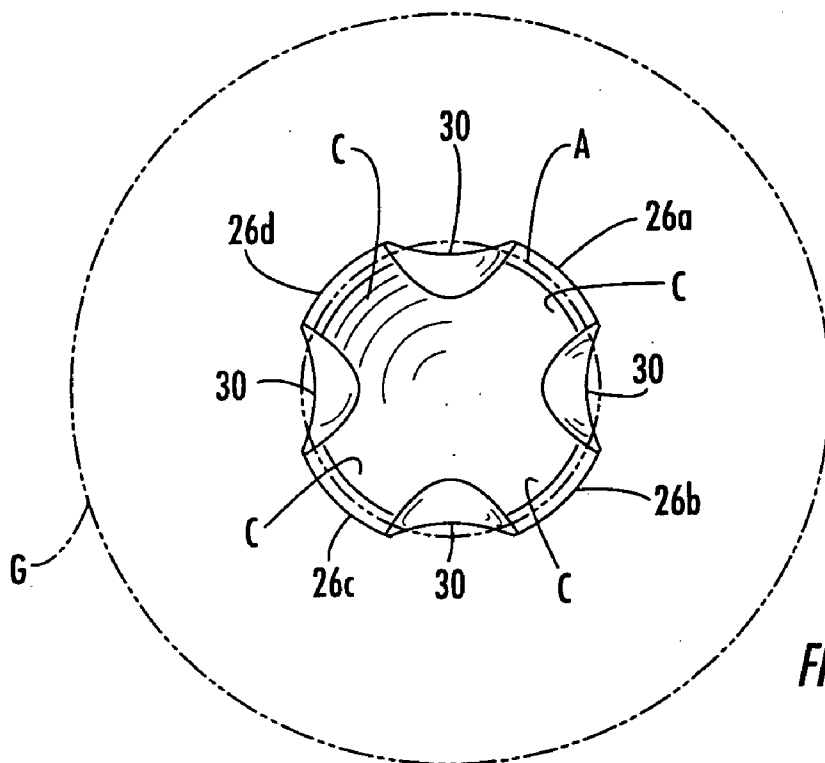

FIG. 2A

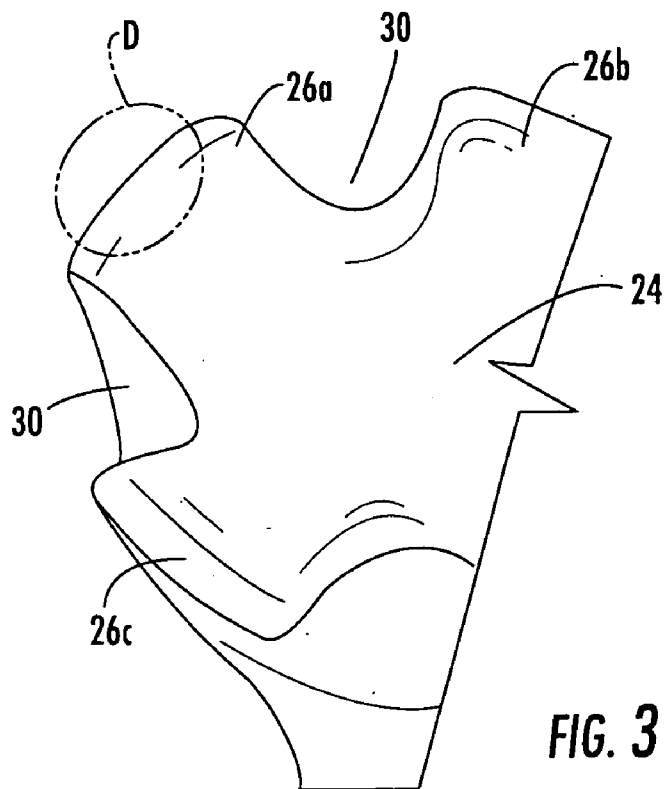
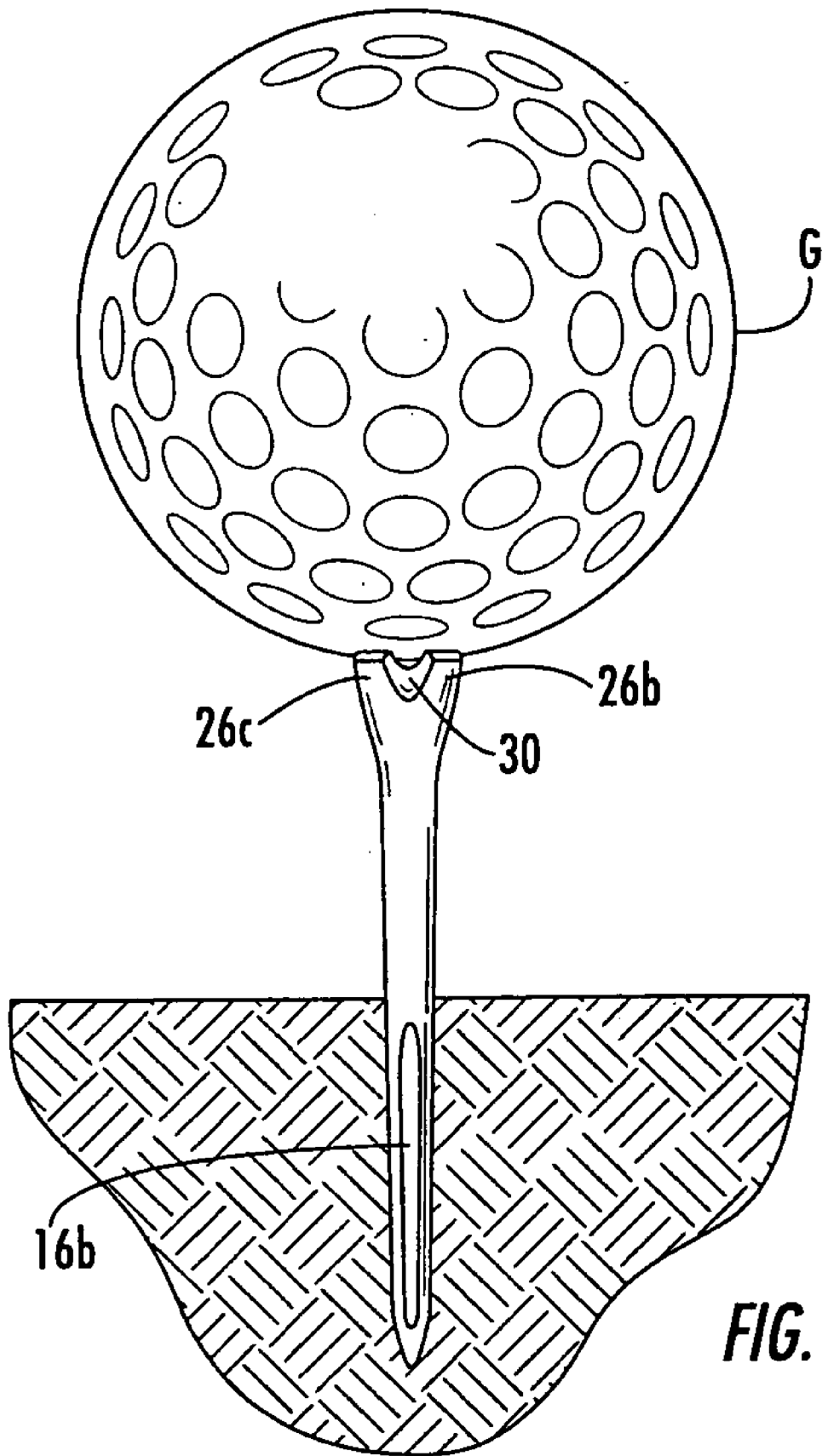

FIG. 3



**FIG. 4**

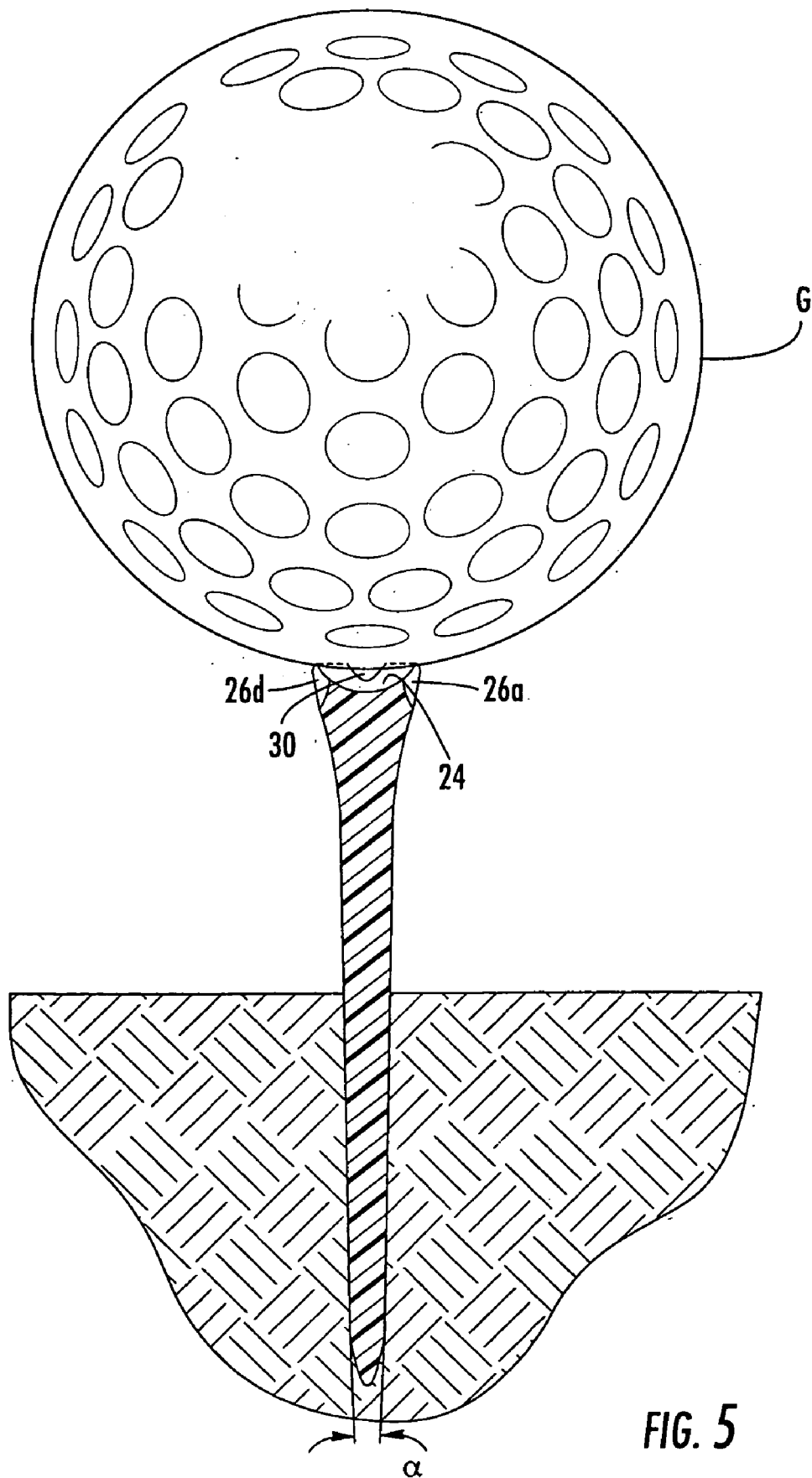

FIG. 5

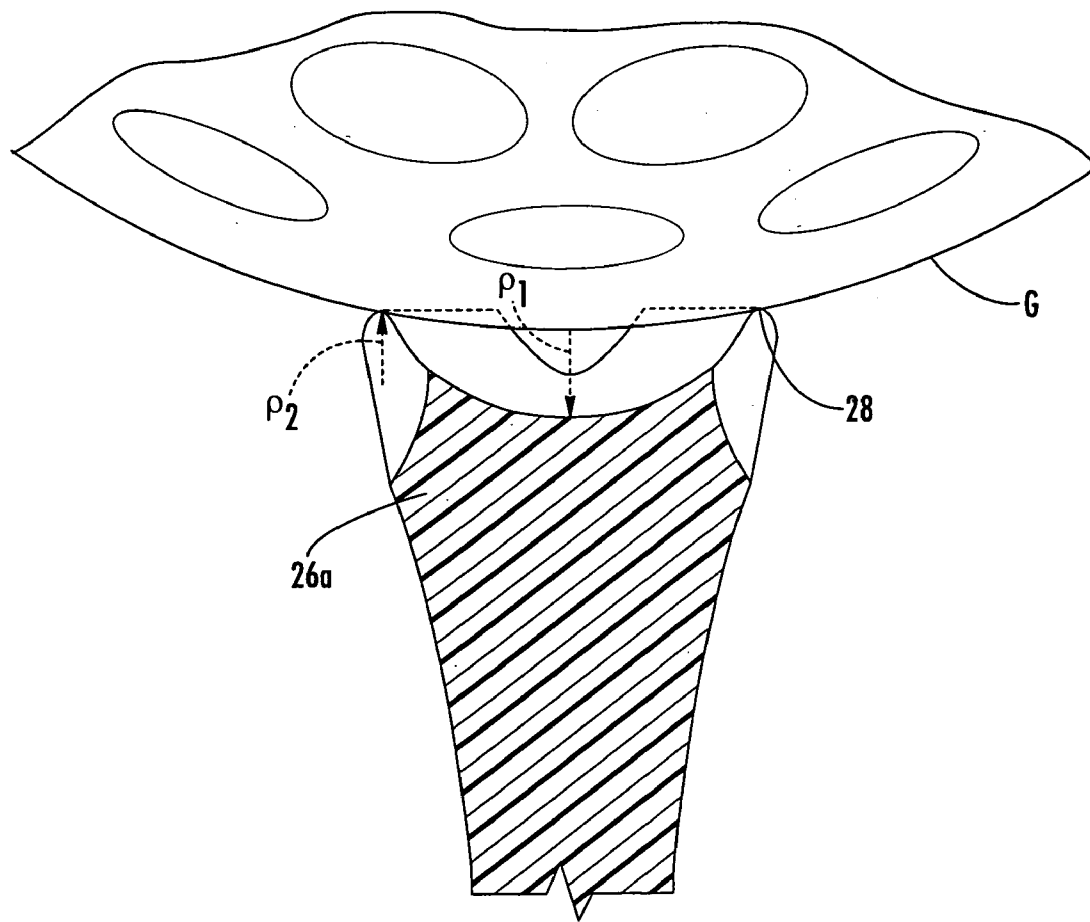

FIG. 5A

**GOLF TEE WITH SUPPORT PRONGS**

**FIELD OF THE INVENTION**

[0001] The present invention relates generally to golf equipment, and more specifically to golf tees employed in striking a golf ball.

**BACKGROUND OF THE INVENTION**

[0002] The overwhelming majority of golfers use golf tees during their rounds of golf. As is well-known, a golf tee is placed in the ground or other underlying surface, and the ball rests atop the tee; because the ball resides above the ground, there is more margin for error in striking the ball with a golf club, and often greater distance can be achieved when a tee is used. A golfer is permitted to use a tee on the first shot of every hole.

[0003] A conventional golf tee is formed of wood and typically includes a cupped support surface upon which a golf ball rests and a cylindrical shaft underlying the support surface that penetrates the ground. The support surface has a radius of curvature that is approximately equal to that of a golf ball. The rim of the support surface, which typically has a diameter of about 0.500 inch, ordinarily has a relatively sharp edge. The shaft of a conventional tee is substantially cylindrical and terminates in a pointed tip to facilitate insertion into the ground.

[0004] One of the problems with a conventional tee results from the interaction between the support surface and the ball as the ball is struck. More specifically, most, if not all, of the support surface of the tee is in contact with the ball as the ball rests thereon. This contact creates friction that can negatively impact the launch of the ball from the tee. In addition, the sharp edges and any imperfections of the rim of the tee can "catch" on the surface of the ball and further increase the friction on the launched ball as well as impart a degree of side spin onto the ball that can reduce accuracy. Also, the sharp rim of the tee is also somewhat fragile and can be damaged as the club face strikes it.

[0005] In addition, a conventional tee typically has a cylindrical shank that is uniform in diameter from just below the cupped support surface to within about 0.150" of the tee bottom, at which point the tee tapers sharply to the tip. The uniform diameter of a conventional tee tends to create a cylindrical hole in the ground. When the ball/tee is struck with a golf club, a significant portion of the force (often about 30-40 lbs) is concentrated into the tee to ground interface. A common failure mechanism of wooden tees is fracture at that interface point because the tee cannot smoothly exit the ground from the cylindrical hole.

**SUMMARY OF THE INVENTION**

[0006] These and other issues may be addressed by a golf tee of the present invention. As a first aspect, the present invention is directed to embodiments of a golf tee comprising: an elongate shaft having opposed upper and lower ends, the lower end configured to be inserted into an underlying surface; and a support cup that is configured to support a golf ball from beneath and that merges with the shaft. The support cup has a base portion and further includes at least three arcuate support prongs projecting upwardly from the base portion. The support prongs define a discontinuous

annulus about the periphery of the support cup. In this configuration, the contact area between the support cup and the ball can be reduced, which can in turn reduce the amount of friction between the ball and tee and decrease the risk of imperfections in the tee negatively impacting ball flight.

[0007] In some embodiments, the upper surface of the base portion of the support cup is recessed from the support prongs. In certain embodiments, the shaft includes flutes or other projections or recesses that can resist twisting of the tee during impact.

[0008] As a second aspect, the present invention is directed to embodiments of a golf tee comprising: an elongate shaft having opposed upper and lower ends, the lower end configured to be inserted into an underlying surface; and a support cup that is configured to support a golf ball from beneath and that merges with the shaft. As with the embodiments described above, the support cup has a base portion and further includes at least three arcuate support prongs projecting upwardly from the base portion. In these embodiments, each of the support prongs has a convex contact surface and is of a secant length that is greater than that of a dimple of a golf ball. Again, in this configuration, the contact area between the support cup and the ball can be reduced to that portion of the golf ball that is outside the golf ball dimples.

[0009] As a third aspect, the present invention is directed to embodiments of a golf tee comprising a shaft and a support cup as described immediately above, wherein each of the support prongs has a convex contact surface and a secant length such that the total contact area between the contact surfaces and a golf ball resting on the contact surfaces is between about 0.0036 and 0.0045 in<sup>2</sup>.

**BRIEF DESCRIPTION OF THE FIGURES**

[0010] FIG. 1 is a bottom perspective view of an embodiment of a golf tee in accordance with the present invention.

[0011] FIG. 2 is a top view of the golf tee of FIG. 1.

[0012] FIG. 2A is a top view of the golf tee of FIG. 1 with a golf ball illustrated in phantom line.

[0013] FIG. 3 is an enlarged partial top perspective view of the golf tee of FIG. 1 showing an exemplary golf ball dimple in comparison to the support prong.

[0014] FIG. 4 is a side view of the golf tee of FIG. 1 inserted into the ground with a golf ball resting on the support prongs of the tee.

[0015] FIG. 5 is a section view of the golf tee of FIG. 1 inserted into the ground with a golf ball resting on the support prongs of the tee.

[0016] FIG. 5A is an enlarged section view of FIG. 4 showing support prongs supporting a golf ball.

**DETAILED DESCRIPTION OF EMBODIMENTS OF THE INVENTION**

[0017] The present invention will be described more particularly hereinafter with reference to the accompanying drawings. The invention is not intended to be limited to the illustrated embodiments; rather, these embodiments are intended to fully and completely disclose the invention to those skilled in this art. Like numbers refer to like compo-

nents throughout, and certain dimensions and thicknesses may be exaggerated for clarity.

[0018] Referring now to **FIG. 1**, a golf tee, designated broadly at **10**, is illustrated therein. The tee **10** includes an elongate shaft **12** and a support cup **20** attached to and merging with the upper end thereof. These structures are described in greater detail below.

[0019] Referring now to **FIGS. 1 and 3**, the shaft **12** comprises a main body **14** and a tip **18** at its lower end. The body **14** has a length of between about 2.7 and 3.0 inches. In the illustrated embodiment, the body **14** is tapered (i.e., it decreases in diameter with increasing distance from the support cup **20**), with the maximum dimension being between about 0.2 and 0.3 inch and the minimum dimension being between about 0.16 and 0.19 inch. When viewed from the side as in **FIG. 5**, the taper of the body **14** is such that the body defines a taper angle  $\alpha$  of between about 0.75 and 1.5 degrees. The body **14** may optionally include one or more recessed flutes **16a**, **16b** that are positioned diametrically opposed from one another and that extend over a major portion of the length of the body **14**. The flutes **16a**, **16b** (or other recesses into or projections from the main body **14**) may prevent twisting of the tee **10** during impact. The tip **18** tapers quickly from the end of the body **14** to terminate in a sharp point; the tip typically has a length of between about 0.15 and 0.25 inch.

[0020] Referring now to **FIGS. 1, 2 and 3**, the support cup **20** includes a base portion **22** and four support prongs **26a**, **26b**, **26c**, **26d**. The base portion **22** is connected to and merges with the upper end of the shaft body **14**. The base portion **22** has a concave upper surface **24**. In certain embodiments, the upper surface **24** has a radius of curvature  $\rho_1$  (see **FIG. 5A**) that is less than that of a conventional golf ball (a conventional golf ball has a radius of curvature of about 0.84 inch); typically, the radius of curvature  $\rho_1$  of the upper surface **24** is less than 0.6 inch, and can be between 0.3 and 0.5 inch. Having a radius of curvature  $\rho_1$  that is less than the diameter of a golf ball can result in the golf ball resting above the upper surface **24** when on the tee **10**, thereby reducing the contact area (and, in some embodiments, friction and surface irregularities) between the golf ball and the tee.

[0021] Referring now to **FIGS. 1, 2, 3 and 5A**, the prongs **26a**, **26b**, **26c**, **26d** project upwardly from the periphery of the base portion **22**. In the illustrated embodiment, each of the prongs **26a**, **26b**, **26c**, **26d** is identical to the other prongs. As such, only one prong **26a** will be described in detail herein; those skilled in this art will appreciate that the discussion is applicable to the remaining prongs **26b**, **26c**, **26d** also.

[0022] The prong **26a** is arcuate when viewed from above (**FIGS. 2 and 3**). In some embodiments, the prong **26a** has a secant length  $\beta$  that is greater than the diameter of the largest dimple of a conventional golf ball (i.e., about 0.160 inch). Typically, the secant length of the prong **26a** is between about 0.170 and 0.200 inch. With a prong that has a secant length that is greater than the diameter of a golf ball dimple **D** (see **FIG. 3**), the interaction between the prong and the golf ball should be limited to the outer skin of the golf ball (i.e., that portion of the outer surface of the golf ball between the dimples), which can reduce the friction between the tee **10** and the golf ball.

[0023] Referring now to **FIG. 5A**, the prong **26a** also has a convex contact surface **28** upon which a golf ball rests. This contact surface **28** typically has a radius of curvature  $\rho_2$  that is between about 0.040 and 0.060 inch. The inclusion of the convex contact surface **28** on the prong **26a** can reduce the amount of contact area between the tee and a golf ball resting thereon, which in turn can reduce the friction between the ball and the tee **10** and the influence of surface imperfections in the tee on ball flight.

[0024] As can be seen in **FIG. 2**, the prongs **26a**, **26b**, **26c**, **26d** are separated from each other by notches **30**. As such, they define a discontinuous annulus **A** about the periphery of the support cup **20** that can support a golf ball. This discontinuous annulus **A** typically has a diameter of between about 0.4 and 0.6 inch. In the illustrated embodiment, the prongs **26a**, **26b**, **26c**, **26d** are positioned diametrically opposite from one another across the base portion **22**; however, in other embodiments prongs may be arranged about the periphery of the support cup **22** differently. Also, although four prongs **26a**, **26b**, **26c**, **26d** are included in the illustrated embodiment, other embodiments in which at least three prongs are included are also contemplated (e.g., a tee of the present invention may have three, five or six prongs).

[0025] As can be seen in **FIG. 2A**, a golf ball **G** resting on the tee **10** contacts the tee **10** only along four contact arcs **C** (one arc for each prong), with the result that the ball has very little contact area in its interaction with the tee **10**. As a result, a golf ball struck from a resting position atop the tee **10** may experience less friction and, thus, may travel farther than a golf ball struck with a conventional tee. Further, the reduced contact area can diminish the possibility of surface imperfections in the tee **10** influencing ball flight. In some embodiments, the contact area may be less than 0.0045 in<sup>2</sup>, and even as low as 0.0036 in<sup>2</sup>.

[0026] Other aspects of the tee **10** may also improve performance. For example, the presence of the flutes **16a**, **16b** may assist in preventing twisting of the tee **10** on off-center shots. An off-center shot can tend to "spin" a tee into the ground; this twisting motion can adversely impact the launch of the golf ball at impact. The presence of the flutes **16a**, **16b** can prevent such twisting and thereby provide a more stable launch platform.

[0027] Also, the tapering of the main body **14** can improve the life of the tee **10**. As described above, a tee can experience significant force when struck with a golf club and tends to fracture at its interface with the ground. The tapered shape of the main body **14** creates a tapered hole in the ground upon insertion. As a result, at impact the tee **10** can easily exit the tapered hole rather than simply snapping, enabling the tee **10** to be re-used.

[0028] The tee **10** may be made of any number of materials known to those skilled in this art to be suitable for tees. Exemplary materials include polymers such as polylactic acid (PLA), PHA, and, in some instances, wood. In some embodiments, the tee **10** may be formed of a biodegradable material such as those described in U.S. Pat. No. 5,844,066 to Kakizawa, U.S. Pat. No. 5,914,381 to Terado et al., and U.S. Pat. No. 6,213,970 to Anderson et al., the disclosures of each of which are hereby incorporated herein in their entireties. In certain embodiments, it may be desirable to employ a biodegradable polymer, such as a polylactic acid-based material, and in some embodiments it may even be desirable



to employ a biocompostable material. An exemplary material is a polylactic acid-based material with flax fiber or other impact modifier. It may be desirable to select a material that has a low coefficient of friction, as doing so may decrease the amount of ball-tee friction.

[0029] The tee **10** may be formed by any technique known to those skilled in this art to be suitable for the production of items formed of the material of choice. For example, if a polymeric material is used, injection or compression molding or machining may be a suitable manufacturing technique.

[0030] The foregoing is illustrative of the present invention and is not to be construed as limiting thereof. Although exemplary embodiments of this invention have been described, those skilled in the art will readily appreciate that many modifications are possible in the exemplary embodiments without materially departing from the novel teachings and advantages of this invention. As such, all such modifications are intended to be included within the scope of this invention. The scope of the invention is to be defined by the following claims.

**1.** A golf tee, comprising:

an elongate shaft having opposed upper and lower ends, the lower end configured to be inserted into an underlying surface; and

a support cup that is configured to support a golf ball from beneath, the support cup merging with the shaft, the support cup having a base portion having a concave upper surface and further including at least three arcuate support prongs projecting upwardly from the base portion, the support prongs defining a discontinuous annulus about the periphery of the support cup, wherein the base portion upper surface has a radius of curvature of less than 0.6 inch, such that a golf ball resting on the support prongs does not contact the base portion upper surface.

**2.** The golf tee defined in claim 1, wherein each of the support prongs has a secant length that is greater than a dimple on a golf ball.

**3.** The golf tee defined in claim 2, wherein each of the support prongs has a secant length of at least 0.170 inch.

**4.** The golf tee defined in claim 3, wherein each of the support prongs has a secant length of less than 0.200 inch.

**5.** The golf tee defined in claim 1, wherein each of the support prongs has a convex contact surface adapted to contact a golf ball.

**6.** The golf tee defined in claim 1, wherein the at least three support prongs comprises four support prongs.

**7.** (canceled)

**8.** The golf tee defined in claim 1, wherein the elongate shaft includes flutes that resist twisting of the tee when the tee is inserted into the ground.

**9.** The golf tee defined in claim 1, wherein the elongate shaft includes a pointed tip at its lower end and a main body, the main body decreasing in diameter with increasing distance from the support cup.

**10.** The golf tee defined in claim 9, wherein in side view the main body of the elongate shaft forms a taper angle of between about 0.75 and 1.0 degrees over a length of between about 2.7 and 3.0 inches.

**11.** (canceled)

**12.** The golf tee defined in claim 1 formed of a biodegradable material.

**13.** The golf tee defined in claim 11 formed of a biocompostable material.

**14.** The golf tee defined in claim 11, wherein the biodegradable material comprises polylactic acid.

**15.** A golf tee, comprising:

an elongate shaft having opposed upper and lower ends, the lower end configured to be inserted into an underlying surface; and

a support cup that is configured to support a golf ball from beneath, the support cup merging with the shaft, the support cup having a base portion and further including at least three arcuate support prongs projecting upwardly from the base portion, each of the support prongs having a convex contact surface and being of a secant length that is greater than that of a dimple of a golf ball.

**16.** The golf tee defined in claim 15, wherein the secant length of the support prongs is at least 0.170 inches.

**17.** The golf tee defined in claim 16, wherein the secant length of the support prongs is between about 0.170 and 0.200 inch.

**18.** The golf tee defined in claim 15, wherein the convex contact surfaces of the support prongs have a radius of curvature of less than 0.060 inches.

**19.** The golf tee defined in claim 18, wherein the convex contact surfaces of the support prongs have a radius of curvature of between about 0.040 and 0.060 inches.

**20.** The golf tee defined in claim 15, wherein the at least three support prongs comprises four support prongs.

**21.** The golf tee defined in claim 15, wherein the base portion upper surface has a radius of curvature of less than 0.600 inch, such that a golf ball resting on the support prongs does not contact the base portion upper surface.

**22.** The golf tee defined in claim 15, wherein the elongate shaft includes flutes that resist twisting of the tee when the tee is inserted into the ground.

**23.** The golf tee defined in claim 15, wherein the elongate shaft includes a pointed tip at its lower end and a main body, the main body decreasing in diameter with increasing distance from the support cup.

**24.** The golf tee defined in claim 23, wherein in side view the main body of the elongate shaft forms a taper angle of between about 0.75 and 1.5 degrees over a length of between about 2.7 and 3.0 inches.

**25.** The golf tee defined in claim 15 formed of a biodegradable material.

**26.** The golf tee defined in claim 25 formed of a biocompostable material.

**27.** The golf tee defined in claim 15, wherein the base portion further comprises a generally concave upper surface

**28.** The golf tee defined in claim 25, wherein the biodegradable material comprises polylactic acid.

**29.** A golf tee, comprising:

an elongate shaft having opposed upper and lower ends, the lower end configured to be inserted into an underlying surface; and

a support cup that is configured to support a golf ball from beneath, the support cup merging with the shaft, the support cup having a base portion and further including at least three arcuate support prongs projecting

upwardly from the base portion, the support prongs defining a discontinuous annulus about the periphery of the support cup, each of the support prongs having a convex contact surface and being of a secant length that is greater than that of a dimple of a golf ball.

**30.** The golf tee defined in claim 29, wherein the secant length of the support prongs is at least 0.170 inches.

**31.** The golf tee defined in claim 29, wherein the secant length of the support prongs is between about 0.170 and 0.200 inches.

**32.** The golf tee defined in claim 29, wherein the convex contact surfaces of the support prongs have a radius of curvature of less than 0.060 inch.

**33.** The golf tee defined in claim 32, wherein the convex contact surfaces of the support prongs have a radius of curvature of between about 0.040 and 0.060 inch.

**34.** The golf tee defined in claim 29, wherein the at least three support prongs comprises four support prongs.

**35.** The golf tee defined in claim 29, wherein the base portion upper surface has a radius of curvature of less than 0.6 inch, such that a golf ball resting on the support prongs does not contact the base portion upper surface.

**36.** The golf tee defined in claim 29, wherein the elongate shaft includes flutes that resist twisting of the tee when the tee is inserted into the ground.

**37.** The golf tee defined in claim 29, wherein the elongate shaft includes a pointed tip at its lower end and a main body, the main body decreasing in diameter with increasing distance from the support cup.

**38.** The golf tee defined in claim 37, wherein in side view the main body of the elongate shaft forms a taper angle of between about 0.75 and 1.5 degrees over a length of between about 2.7 and 3.0 inches.

**39.** The golf tee defined in claim 29 formed of a biodegradable material.

**40.** The golf tee defined in claim 39 formed of a biocompostable material.

**41.** The golf tee defined in claim 39, wherein the biodegradable material comprises polylactic acid.

**42.** The golf tee defined in claim 29, wherein the base portion further comprises a generally concave upper surface

**43.** A golf tee, comprising:

an elongate shaft having opposed upper and lower ends, the lower end configured to be inserted into an underlying surface; and

a support cup that is configured to support a golf ball from beneath, the support cup merging with the shaft, the support cup having a base portion and further including at least three arcuate support prongs projecting upwardly from the base portion, each of the support prongs having a convex contact surface and being of a secant length such that the total contact area between the contact surfaces and a golf ball resting on the contact surfaces is between about 0.0036 and 0.0045 in<sup>2</sup>.

\* \* \* \* \*