

(19) World Intellectual Property Organization
International Bureau



(43) International Publication Date
4 October 2001 (04.10.2001)

PCT

(10) International Publication Number
WO 01/73989 A1

- (51) International Patent Classification⁷: H04J 3/17, (74) Agent: FRANK B. DEHN & CO.; 179 Queen Victoria Street, London EC4V 3EL (GB).
H04Q 7/38
- (21) International Application Number: PCT/GB01/01353
- (22) International Filing Date: 27 March 2001 (27.03.2001)
- (25) Filing Language: English
- (26) Publication Language: English
- (30) Priority Data: 0007655.4 29 March 2000 (29.03.2000) GB
- (71) Applicant (for all designated States except US): SIMOCO INTERNATIONAL LIMITED [GB/GB]; P.O. Box 24, St. Andrews Road, Cambridge CB4 1DP (GB).
- (72) Inventors; and
- (75) Inventors/Applicants (for US only): STEPHENS, Peter, William [GB/GB]; 10 St. Catherines, Ely, Cambridge CB6 1AP (GB). FRAYLING-CORK, Robert [GB/GB]; 51 Barkham Road, Wokingham, Berkshire RG41 2RG (GB).
- (81) Designated States (national): AE, AG, AL, AM, AT, AT (utility model), AU, AZ, BA, BB, BG, BR, BY, BZ, CA, CH, CN, CO, CR, CU, CZ, CZ (utility model), DE, DE (utility model), DK, DK (utility model), DM, DZ, EE, EE (utility model), ES, FI, FI (utility model), GB, GD, GE, GH, GM, HR, HU, ID, IL, IN, IS, JP, KE, KG, KP, KR, KZ, LC, LK, LR, LS, LT, LU, LV, MA, MD, MG, MK, MN, MW, MX, MZ, NO, NZ, PL, PT, RO, RU, SD, SE, SG, SI, SK, SK (utility model), SL, TJ, TM, TR, TT, TZ, UA, UG, US, UZ, VN, YU, ZA, ZW.
- (84) Designated States (regional): ARIPO patent (GH, GM, KE, LS, MW, MZ, SD, SL, SZ, TZ, UG, ZW), Eurasian patent (AM, AZ, BY, KG, KZ, MD, RU, TJ, TM), European patent (AT, BE, CH, CY, DE, DK, ES, FI, FR, GB, GR, IE, IT, LU, MC, NL, PT, SE, TR), OAPI patent (BF, BJ, CF, CG, CI, CM, GA, GN, GW, ML, MR, NE, SN, TD, TG).

Published:
— with international search report

[Continued on next page]

(54) Title: DIGITAL TRANSMISSION

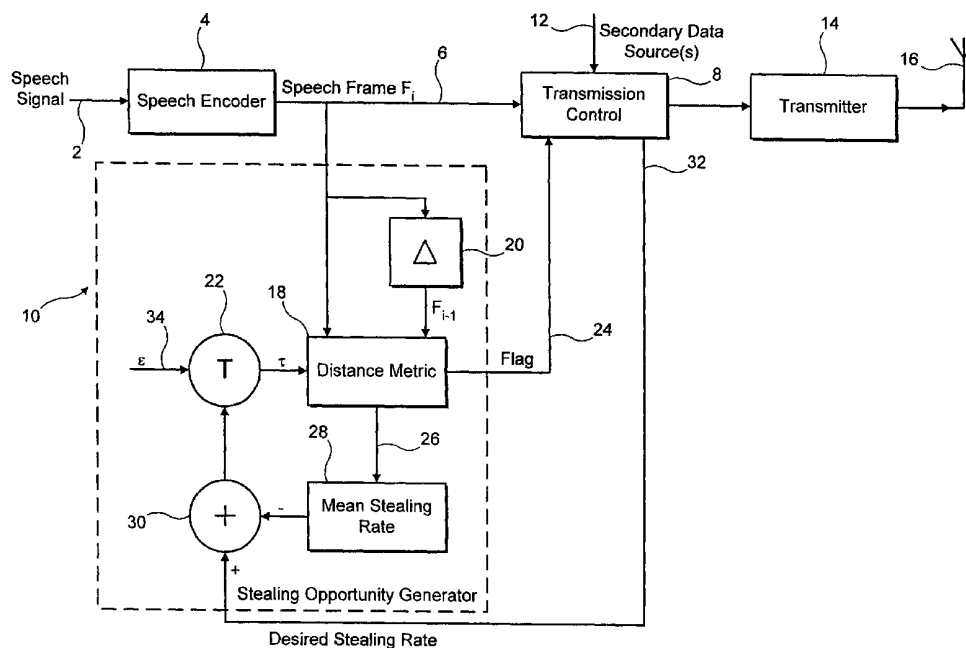

(57) Abstract: A method is disclosed of indicating when parts of a main transmission in the form of encoded speech may be stolen in order to transmit a secondary transmission such as signalling or user data in its place. The parameters of adjacent frames of the encoded speech are compared to determine a difference parameter. If the difference is below a threshold, an indication is given that the frame may be stolen and therefore be replaced at the receiver by repeating the adjacent frame. The threshold may be varied to give a desired average rate at which stealing indications are given.

WO 01/73989 A1



For two-letter codes and other abbreviations, refer to the "Guidance Notes on Codes and Abbreviations" appearing at the beginning of each regular issue of the PCT Gazette.

Digital Transmission

5 This invention relates to digital transmission and particularly, but not exclusively, to a method of and apparatus for replacing certain portions of one digital transmission with another.

10 Many digital communication systems are used primarily to transmit speech or other sound. It is also a feature of such digital systems that non-speech data, such as signalling and control information or other data is often required to pass between the two parties. If there is a large amount of such information it is
15 usually transmitted on a separate channel from the actual speech data. This may be done in the frequency domain - i.e. using a channel with a different carrier frequency, or in the time domain - i.e. by allocating time slots for signalling and control information.

20 However, if only a relatively small amount of non-speech data needs to be transmitted, that other data is sometimes transmitted using a technique known as "frame stealing", in which the other data is transmitted in place of portions of speech data by replacing certain
25 portions (e.g. frames) of speech with the non-speech signalling. In such a system the receiving unit detects that non-speech data has been transmitted (which is dealt with separately) and typically masks what would otherwise be a gap in the reproduced speech by
30 interpolating the contents of the missing speech frame from other received speech data, e.g. by repeating the previously received speech frame. Such frame stealing degrades the intelligibility of the reproduced speech since original speech data is lost.

35 The effect that frame stealing has on the intelligibility of the reproduced speech depends to a large degree on the precise contents of the lost speech

- 2 -

frame. For example if the frame happens to fall within
a period of silence such as a pause between words, the
effect will be imperceptible. For this reason, known
frame stealing techniques typically try to steal speech
5 frames selectively based on their energy content so as
to try to steal only essentially silent speech frames.

It has now been realised however that this
technique suffers from a number of problems. Most
importantly an energy measurement is unable to
10 distinguish between actual speech data and noise. As
the noise level rises therefore, the algorithm starts to
break down and will typically begin to replace low
energy parts of the speech proper effectively at random,
which can lead to a serious degradation in
15 intelligibility. Another particular problem recognised
by the Applicants is that within ordinary speech,
consonants are typically of low energy but are of very
high importance to intelligibility. This is especially
so of so-called stop-consonants which tend to have small
20 gaps, which if removed greatly degrade the
intelligibility. An "energy content" stealing algorithm
will tend to steal preferentially consonants and stop-
consonants.

It is an object of the present invention to provide
25 a better frame stealing system and when viewed from a
first aspect the invention provides a method of
determining which portions of a main digital
transmission may be replaced with a second transmission,
comprising determining a difference parameter
30 representing the difference between a certain portion of
the main transmission and a predetermined signal,
comparing said difference parameter with a threshold and
selectively issuing an indication that said portion of
the main transmission may be replaced with the second
35 transmission on the basis of said comparison.

The invention also extends to the corresponding
apparatus and thus when viewed from another aspect

- 3 -

provides an apparatus for determining which portions of a main digital transmission may be replaced with a second transmission comprising means for determining a difference parameter representing the difference between a certain portion of the transmission, and a predetermined signal, and means for selectively issuing an indication that the said portion of the first transmission may be replaced with the second transmission on the basis of said comparison.

Thus it will be seen that in accordance with the invention an indication can be given of appropriate portions of a digital transmission to 'steal' for use in transmitting something else - e.g. signalling. The decision on whether a given portion of the main transmission may appropriately be 'stolen' is made by comparing the portion of the main transmission to be replaced and a predetermined signal, i.e. by in effect determining the effect of replacing that portion with the predetermined signal. The indication that the main signal portion can be stolen is given on the basis of the threshold comparison i.e. whether the effect of replacing it with the predetermined signal portion is sufficiently small. In other words, the transmitter effectively assumes that the receiver will replace the main signal portion with the predetermined signal portion in the event that the main signal portion is stolen and assesses the effect of that replacement to make its stealing decision. Preferably the comparison is such that the indication is given if the difference parameter is below the threshold. However alternative arrangements may be envisaged whereby the threshold is defined such that an indication is given only if it is exceeded. In other words, the difference parameter may instead be thought of as a 'similarity' parameter.

The above technique provides a means for identifying better those portions of the original transmission that may be replaced with another

- 4 -

transmission whilst minimising the effect upon the reproduced received signal.

Considering the system as a whole therefore when viewed from a further aspect the invention may be seen
5 as providing a method of determining which part of a main transmission may be stolen to transmit secondary data in its place, comprising determining what the stolen part would be replaced with at the receiver, assessing the effect of performing said replacement and
10 indicating whether the replacement is allowable on the basis of said assessment.

Similarly the invention extends to apparatus for determining which part of a main transmission may be stolen to transmit secondary data in its place,
15 comprising means for determining what the stolen part would be replaced with at the receiver, means for assessing the effect of performing said replacement and means for indicating whether the replacement is allowable on the basis of said assessment.

In the above aspects of the invention, the replacement allowable indication is preferably given if the assessed effect compares favourably with (e.g. is below) a particular threshold. The assessment is preferably carried out by comparing the part of the main
20 transmission that it is desired to steal with what it is determined that it would be replaced with at the receiver, i.e. the effect of replacement is assessed by determining the difference between the original part and its replacement.

The invention is applicable to any suitable data link e.g. a fixed link such as a wire or optical link. It is likely to have greater application however in radio communications where bandwidth tends to be more acutely limited.

35 Although the invention may find application whatever the nature of the main transmission, it is of greatest benefit when the main transmission is speech.

- 5 -

Preferred embodiments of the invention allow portions of speech to be successfully stolen and used, e.g. for signalling data, whilst having a minimal impact on intelligibility. Indeed preferred embodiments of the invention can provide significantly improved intelligibility over "energy content" algorithms for the same average level of stealing.

The predetermined signal with which the main signal portion is compared should be the signal which it is expected that the receiver would use to fill the gap in the main transmission if a portion thereof is replaced with the second transmission. The transmitter will typically know what the receiver will replace the missing main signal portion with, since such transmission systems typically use predetermined signals and/or algorithms to compensate for missing data.

The predetermined signal could be fixed - e.g. a null signal representing silence. More preferably however this signal is dependent upon the content of the main transmission (since typically any compensation algorithm will use the original signal as a base). In particularly preferred embodiments the signal is based on or derived from, another portion of the main transmission, most preferably a portion adjacent the portion which it is proposed to remove (the portions being adjacent at least in the original signal, i.e. ignoring the effects of interleaving, etc.).

Thus where the main transmission is of a series of speech frames, the predetermined signal could be based on the immediately preceding or immediately succeeding speech frame, or indeed a combination of the two. These techniques would be applicable where the receiver compensates for missing data portions by extrapolating the transmission forwards or backwards or both to fill the gap. In a simple compensation arrangement a previously transmitted portion of the main signal, or one about to be transmitted could be repeated and thus

- 6 -

the predetermined signal portion should be a previously transmitted portion of the main signal or one about to be transmitted accordingly. This would tend to work best when the data being transmitted is temporarily stationary - i.e. is not changing with time. Another, slightly more complex, possibility would be an interpolation between the preceding and succeeding portions - e.g. an average of the two. This would not require the data to be stationary but merely changing at a constant rate and it is therefore preferred in some embodiments. Although not preferred, it would of course also be possible to measure the way in which the data was changing in preceding and/or succeeding portions and calculate a more complex extrapolation/interpolation. Of course if any use is made of succeeding portions, a buffer and consequent reception delay are necessary.

The main transmission, upon which the effect of stealing is assessed, could be the original, raw, e.g. speech, data. In other words the difference parameter in accordance with the invention can be determined as a suitable function of differences between the raw data in the main transmission portion and the predetermined signal in a corresponding form. However, where the raw speech, etc., is converted into a series of parameters for transmission, the comparison is preferably between the parameterised speech and the predetermined signal in a corresponding form e.g. an adjacent portion of parameterised transmission in the preferred embodiment. Most preferably, the main transmission comprises a coded speech signal, e.g. coded in accordance with a communication protocol such as GSM or preferably TETRA (TERrestrial Trunked RADio).

Comparing parameterised data such as coded speech is advantageous since it can allow a large reduction in the amount of processing required since the parameterised data, for example, generally occupies far fewer bits than the raw data. It also gives a more

- 7 -

accurate indication of the effect of stealing on the transmission since it is the parameterised form which is actually transmitted.

5 Alternatively one or more parameters may be derived from the raw data or another derivative thereof in order to characterise it specifically for determining the difference parameter in accordance with the invention.

10 The portion of the main transmission which is tested for potential replacement may be of variable length, but preferably it is of fixed length. This simplifies processing and avoids the possibility of excessively long portions of the main transmission being replaced. Where the main transmission is in the form of regular discrete signal portions, e.g. frames or
15 timeslots, the main transmission portion preferably corresponds to those portions, e.g. frames or timeslots.

20 Thus, for example, where, as in the TETRA protocol or another similar protocol, the speech encoding results in the transmission of periodically repeating frames, each of which comprises a series of parameters derived from the sound data, the main transmission portion tested for possible replacement is preferably in units of such frames, most preferably a single frame. In the most preferred embodiment the difference parameter is
25 then determined using the differences between corresponding values of suitable speech parameters in adjacent frames. In the TETRA protocol for example parameters are defined representing the shape of the spectral envelope, the residual excitation signal after
30 inverse filtering by a whitening filter to remove the spectral characteristic, the energy content and the extracted pitch period.

35 In a simple embodiment the difference parameter could be determined by calculating the cumulative sum of the differences between the elements of data being compared. However it has been appreciated that in some cases certain of the parameterised data could be much

- 8 -

more important to the intelligibility of the main signal, e.g. speech, eventually obtained when the signal is decoded. This would be the case for TETRA encoded speech. Preferably therefore a weighting factor is
5 assigned to each respective parameter, data, bit, etc. of the main signal portion being compared according to its importance to the reproducibility and intelligibility of the main signal.

In the case of a TETRA speech signal, for example,
10 a weight of say 100 might be applied to class 2 bits, a weight of 10 for class 1 bits and a weight of 1 for class 0 bits. Of course many different distributions of weights are possible, even for a given protocol as well as for different protocols. In some embodiments it may
15 be decided for example to use only certain data bits in the comparison - i.e. effectively to apply a zero weight to the other bits. In preferred embodiments however all or substantially all of the parameters are compared.

The Applicants have further appreciated that since
20 the gaps in speech are inherently unpredictable, the frequency with which suitable frames are indicated as being available for stealing when using a "speech energy" stealing algorithm is similarly unpredictable, which limits the usefulness of that stealing assessment
25 technique since the rate at which data can therefore be transmitted is variable.

However, it has been further appreciated that in the case of the present invention, by adjusting the stealing decision threshold up or down, stealing
30 opportunities will, on average, be given with a greater or lesser frequency respectively. Thus in a particularly preferred embodiment the replacement indicating threshold is adjusted, e.g. in accordance with the desired secondary data transmission rate, in
35 order that the average frequency with which said indication (that a portion of the main transmission may be replaced) is given corresponds to a desired given

frequency. This preferred arrangement is considered to represent an additional invention since it gives the benefit that a predictable frequency of stealing can be ensured to allow e.g. signalling or a low-rate data-
5 stream to be transmitted without unpredictable intervals which might, especially in the case of signalling, not be tolerable. This is in addition to the improved intelligibility provided by the invention.

Thus when viewed from a yet further aspect the
10 present invention provides a method of replacing portions of one digital transmission with a second transmission comprising establishing a parameter derived from a portion of the main transmission proposed for replacement, comparing said parameter with a threshold
15 and indicating whether said portion may be replaced with said second transmission on the basis of said comparison, said method further comprising adjusting said threshold to achieve a desired average proportion of replacement.

Correspondingly the invention provides apparatus
20 for replacing portions of one digital transmission with a second transmission comprising means for establishing a parameter derived from a portion of the main transmission proposed for replacement, means for
25 comparing said parameter with a threshold and means for indicating that said portion may be replaced with said second transmission on the basis of said comparison, said apparatus further comprising means for adjusting said threshold to achieve a desired average proportion
30 of replacement of said main transmission with said second transmission.

The preferred embodiments which compare the main signal portion which it is proposed to replace with other main signal portions effectively look for slowly
35 varying portions of the signal, e.g. speech, i.e. those portions for which adjacent portions will be very similar and so may be easily interchanged. It has been

appreciated that in the case of ordinary speech, this will tend to result in portions of vowel sounds being replaced since these tend to vary slowly over their duration. This is advantageous to intelligibility since
5 vowels tend to be of high energy, and thus suffer less from the effects of noise, and have a relatively long duration so that a relatively higher rate of stealing portions is achievable without too adverse an effect on intelligibility.

10 When viewed from a further aspect therefore the present invention provides a method of determining which portions of a main digital transmission may be replaced with a second transmission, comprising analysing said main transmission to determine which portions thereof
15 are varying more slowly than a threshold amount and indicating that those portions may be replaced with the second transmission. It also correspondingly provides an apparatus for determining which portions of a main digital transmission may be replaced with a second
20 transmission, comprising means for analysing said main transmission to determine which portions thereof are varying more slowly than a threshold amount and means for indicating that those portions may be replaced with the second transmission.

25 It will be appreciated that if interpolation or a more complex method of extrapolation than repeating portions is used, the statements of invention above will be equally applicable with the comparison of the rate of change of the main transmission being replaced by a
30 comparison between the variation of said rate of change and a threshold.

The second transmission, i.e. that transmitted during the portions of the first transmission which are 'stolen' could be related to the first transmission -
35 e.g. signalling such as encryption synchronisation data required for the successful decryption of an encrypted first transmission. Alternatively it could be

signalling for another transmission such as a different channel, or even a completely separate low-rate data channel - e.g. for transmitting text.

The method and apparatus of the invention may be implemented using pure hardware means such as discrete components or hard-wired logic gates. Alternatively, the invention may be implemented at least partially using software, e.g. computer programs. It will thus be seen that when viewed from a further aspect, the present invention provides computer software specifically adapted to carry out the methods hereinabove described when installed on data processing means.

Furthermore it will be appreciated that the means specified in the apparatus of the invention may similarly comprise computer software specifically adapted to carry out the methods hereinabove described when installed on data processing means, and a computer program element comprising computer software code portions for performing the methods hereinabove described when the program element is run on a computer.

The invention also extends to a carrier comprising such software which when used to operate an apparatus for determining which portions of a first digital transmission may be replaced with a second transmission comprising a digital computer, causes, in conjunction with said computer, said apparatus to carry out the steps of the method of the present invention. Such a carrier could be a physical storage medium such as a ROM chip, CD ROM or disk, or could be a signal such as an electronic signal over wires, an optical signal or a radio signal such as to a satellite or the like.

It will further be appreciated that not all steps of the invention need be carried out by computer software and thus from a further broad aspect the present invention provides computer software such software installed on a carrier for carrying out at least one of the steps of the methods set out

- 12 -

hereinabove. Similarly, not all of the means specified in the apparatus of the invention need comprise computer software and thus in the general preferred case, it is at least one of such means which comprises computer software.

5 A preferred embodiment of the present invention will now be described, by way of example only, with reference to the accompanying Figure which is a schematic block diagram of a digital radio transmitter apparatus embodying the present invention.

10 Firstly, giving a broad overview, a raw digitised speech signal 2 is operated upon by a speech encoder unit 4 to give an encoded speech signal 6. This codes the speech using the TETRA protocol. This output signal 6 is fed into one input of a transmission control unit 8 and also as the input to a stealing opportunity generator 10. The stealing opportunity generator 10 also receives an input from the transmission control unit 8 to indicate the desired stealing rate and gives a corresponding output to the transmission control unit to indicate whether to transmit from the encoded speech signal 6 or a secondary data source 12. The chosen transmission is transmitted by a transmitter 14 via an aerial 16.

25 In the present example, it is assumed that the receiver will compensate for missing speech data by simply repeating the immediately preceding speech frame. However, as discussed above, other compensation arrangements can be used.

30 The detailed operation of the device will now be described as follows. The stream of raw digitised speech data 2 is encoded by the encoder 4 into a series of frames, each of which comprises a number of parameters representing the original data. Each frame is fed simultaneously to a comparison unit 18 and a delay buffer 20 which in turn also feeds into the comparison unit 18. The delay buffer 20 delays each

35

- 13 -

frame by exactly one frame so that the comparison unit therefore acts on a given frame (received directly) and the preceding frame (received via the buffer 20) (which it is assumed that the receiver will replace the current
5 frame with if it is stolen).

The comparison unit 18 calculates a difference parameter S_i between the two frames by employing the following metric:

$$S_i = \sum_{j=1}^n |F_{i,j} - F_{i-1,j}| \cdot W_j$$

10 Where S_i is the difference parameter for the i th frame, F_i is the i th encoded frame (comprising n parameter codes) and W_j is the weight of the j th bit in the frame. A weight of 100 is applied to each class 2 bit in the frame, a weight of 10 is applied to each class 1 bit and
15 a weight of 1 is applied to each class 0 bit.

The comparison unit 18 compares the difference parameter S_i with a threshold value set in accordance with a threshold input from a threshold setting unit 22. If the difference parameter is higher than the threshold
20 the comparison unit 18 gives an output 24 to the transmission control unit 8 to indicate that the frame F_i should be transmitted. However if S_i is lower than the threshold, a different signal is given on the output 24 to indicate that a frame of data from the secondary data
25 source 12 may be transmitted instead.

An output flag 26 similar to the output 24 is fed into a computing unit 28 which computes the ratio of frames for which the difference parameter S_i is lower than the present threshold, i.e. the average rate at
30 which frames are indicated as being appropriate for stealing. The resulting current mean stealing rate R' is fed to the inverting input of an adder unit 30 which compares the actual stealing rate with the desired rate

- 14 -

R_D set by the transmission control unit 8 in response to the data rate of the secondary data source 12, and fed to the non-inverting input of the adder 30 from an output 32. The difference between the two rates is used
5 by the threshold setting unit 22 to update the threshold using the following formula:

$$t_i = t_{i-1} + e(R_D - R')$$

10 where t_i =threshold at time i ,
e=loop gain
 R_D =desired stealing rate
 R' =current mean stealing rate.

Thus it will be seen that the threshold setting
15 unit will increase the threshold (to increase the average stealing rate) or to decrease it (to lower the average stealing rate) until the desired rate is achieved. The loop gain e is determined by a further input 34 to the threshold setting unit 22 which
20 determines the rate at which the threshold is varied. This is adjusted to ensure stability in the system.

It will be appreciated by those skilled in the art that whilst an embodiment of the invention has been described with reference to discrete blocks, the
25 embodiment may equally be realised in hardware or in software, in which case some or all of the blocks described would merely represent functional modules within the software. It will also be understood that although the exemplary embodiment described operates
30 under the TETRA protocol, any other suitable protocol could be used.

Claims

1. A method of determining which portions of a main digital transmission may be replaced with a second transmission, comprising determining a difference parameter representing the difference between a certain portion of the main transmission and a predetermined signal, comparing said difference parameter with a threshold and selectively issuing an indication that said portion of the main transmission may be replaced with the second transmission on the basis of said comparison.
2. A method as claimed in claim 1 comprising issuing said indication if said difference parameter is below said threshold.
3. A method as claimed in claim 1 or 2 wherein said predetermined signal comprises what it is determined that the portion of the main transmission would be replaced with at the receiver.
4. A method as claimed in claim 2 wherein said predetermined signal is based on or derived from the main transmission.
5. A method as claimed in claim 4 wherein said predetermined signal comprises a portion of the main transmission adjacent the portion it is proposed to replace.
6. A method as claimed in any preceding claim wherein said certain portion of the main transmission comprises at least one frame or timeslot.
7. A method as claimed in any preceding claim wherein said main transmission comprises speech.

8. A method as claimed in any preceding claim wherein said main transmission comprises a parameterised signal.

5 9. A method as claimed in claim 8 comprising encoding a speech signal prior to determining said difference parameter.

10 10. A method as claimed in claim 8 or 9 comprising comparing adjacent frames or timeslots of encoded speech in order to determine said difference parameter.

15 11. A method as claimed in claim 8, 9 or 10 comprising comparing all or substantially all of the parameters of said parameterised signal.

20 12. A method as claimed in any preceding claim comprising assigning a weighting factor to respective parts of the main transmission portion according to their importance to the reproducibility and intelligibility of the main transmission.

25 13. A method of determining which part of a main transmission may be stolen to transmit secondary data in its place, comprising determining what the stolen part would be replaced with at the receiver, assessing the effect of performing said replacement and indicating whether the replacement is allowable on the basis of said assessment.

30 14. A method as claimed in claim 13 comprising comparing the assessed effect with a threshold and selectively indicating that said replacement is allowable on the basis of said comparison.

35 15. A method as claimed in any one of claims 1 to 12 or 14 comprising adjusting said threshold to give a desired

- 17 -

average frequency of indicating that a portion of the main transmission may be replaced.

5 16. A method of replacing portions of one digital transmission with a second transmission comprising establishing a parameter derived from a portion of the main transmission proposed for replacement, comparing said parameter with a threshold and indicating whether said portion may be replaced with said second
10 transmission on the basis of said comparison, said method further comprising adjusting said threshold to achieve a desired average proportion of replacement.

15 17. A method of determining which portions of a main digital transmission may be replaced with a second transmission, comprising analysing said main transmission to determine which portions thereof are varying more slowly than a threshold amount and indicating that those portions may be replaced with the
20 second transmission.

18. Computer software specifically adapted to carry out a method as claimed in any of the preceding claim when installed on data processing means.

25

19. A data carrier comprising computer software for carrying out a method as claimed in any of the preceding claims.

30 20. An apparatus for determining which portions of a main digital transmission may be replaced with a second transmission comprising means for determining a difference parameter representing the difference between a certain portion of the transmission, and a
35 predetermined signal, and means for selectively issuing an indication that the said portion of the first transmission may be replaced with the second

- 18 -

transmission on the basis of said comparison.

21. An apparatus as claimed in claim 20 wherein said
means for issuing is arranged to issue said indication
5 if said difference parameter is below said threshold.

22. An apparatus as claimed in claim 21 or 22
comprising means for comparing adjacent frames or
timeslots of an encoded speech signal in order to
10 determine said difference parameter.

23. An apparatus for replacing portions of one digital
transmission with a second transmission comprising means
for establishing a parameter derived from a portion of
15 the main transmission proposed for replacement, means
for comparing said parameter with a threshold and means
for indicating that said portion may be replaced with
said second transmission on the basis of said
comparison, said apparatus further comprising means for
20 adjusting said threshold to achieve a desired average
proportion of replacement of said main transmission with
said second transmission.

24. Apparatus for determining which part of a main
25 transmission may be stolen to transmit secondary data in
its place, comprising means for determining what the
stolen part would be replaced with at the receiver,
means for assessing the effect of performing said
replacement and means for indicating whether the
30 replacement is allowable on the basis of said
assessment.

25. An apparatus for determining which portions of a
main digital transmission may be replaced with a second
35 transmission, comprising means for analysing said main
transmission to determine which portions thereof are
varying more slowly than a threshold amount and means

- 19 -

for indicating that those portions may be replaced with the second transmission.

INTERNATIONAL SEARCH REPORT

International Application No

PCT/GB 01/01353

A. CLASSIFICATION OF SUBJECT MATTER
 IPC 7 H04J3/17 H04Q7/38

According to International Patent Classification (IPC) or to both national classification and IPC

B. FIELDS SEARCHED

Minimum documentation searched (classification system followed by classification symbols)

IPC 7 H04J G10L H04Q

Documentation searched other than minimum documentation to the extent that such documents are included in the fields searched

Electronic data base consulted during the international search (name of data base and, where practical, search terms used)

EPO-Internal, WPI Data, PAJ, INSPEC

C. DOCUMENTS CONSIDERED TO BE RELEVANT

Category *	Citation of document, with indication, where appropriate, of the relevant passages	Relevant to claim No.
X Y	US 5 511 072 A (DELPRAT MARC) 23 April 1996 (1996-04-23) column 1, line 10 -column 4, line 44 column 4, line 65 -column 9, line 16; figures 2,3 column 9, line 37 -column 10, line 61; figure 4 ---	1-14, 17-22,25 15,16, 23,24
X	US 5 812 965 A (MASSALOUX DOMINIQUE) 22 September 1998 (1998-09-22) column 1, line 5 -column 2, line 15 column 2, line 41 -column 3, line 25 column 4, line 8 -column 17, line 52; figures 1-4B --- -/--	1-9,13, 14, 17-22, 24,25

Further documents are listed in the continuation of box C.

Patent family members are listed in annex.

* Special categories of cited documents:

A document defining the general state of the art which is not considered to be of particular relevance

E earlier document but published on or after the international filing date

L document which may throw doubts on priority claim(s) or which is cited to establish the publication date of another citation or other special reason (as specified)

O document referring to an oral disclosure, use, exhibition or other means

P document published prior to the international filing date but later than the priority date claimed

T later document published after the international filing date or priority date and not in conflict with the application but cited to understand the principle or theory underlying the invention

X document of particular relevance; the claimed invention cannot be considered novel or cannot be considered to involve an inventive step when the document is taken alone

Y document of particular relevance; the claimed invention cannot be considered to involve an inventive step when the document is combined with one or more other such documents, such combination being obvious to a person skilled in the art.

& document member of the same patent family

Date of the actual completion of the international search

12 July 2001

Date of mailing of the international search report

19/07/2001

Name and mailing address of the ISA

European Patent Office, P.B. 5818 Patentlaan 2
 NL - 2280 HV Rijswijk
 Tel. (+31-70) 340-2040, Tx. 31 651 epo nl,
 Fax: (+31-70) 340-3016

Authorized officer

Roldán Andrade, J

INTERNATIONAL SEARCH REPORT

In ternational Application No
PCT/GB 01/01353

C.(Continuation) DOCUMENTS CONSIDERED TO BE RELEVANT		
Category °	Citation of document, with indication, where appropriate, of the relevant passages	Relevant to claim No.
Y	<p>US 4 672 669 A (DESBLACHE ANDRE ET AL) 9 June 1987 (1987-06-09) column 1, line 7 -column 2, line 7 column 2, line 23 -column 3, line 11; figure 1 column 4, line 52 -column 7, line 58; figures 7-9</p> <p style="text-align: center;">---</p>	<p>15,16, 23,24</p>
A	<p>US 5 757 851 A (SAEGUSA YASUHIRO) 26 May 1998 (1998-05-26) column 1, line 10 - line 64 column 2, line 23 -column 3, line 54; figure 1 column 4, line 1 - line 53; figure 3 column 5, line 65 -column 6, line 25; figure 6</p> <p style="text-align: center;">-----</p>	<p>1-25</p>

INTERNATIONAL SEARCH REPORT

 International Application No
 PCT/GB 01/01353

Patent document cited in search report	Publication date	Patent family member(s)	Publication date
US 5511072 A	23-04-1996	FR 2709893 A	17-03-1995
		AT 173874 T	15-12-1998
		DE 69414789 D	07-01-1999
		DE 69414789 T	22-04-1999
		DK 642285 T	09-08-1999
		EP 0642285 A	08-03-1995
		ES 2123736 T	16-01-1999
		FI 944038 A	07-03-1995
		JP 3072881 B	07-08-2000
		JP 7254879 A	03-10-1995
US 5812965 A	22-09-1998	FR 2739995 A	18-04-1997
		EP 0768770 A	16-04-1997
		JP 9179590 A	11-07-1997
US 4672669 A	09-06-1987	EP 0127718 A	12-12-1984
		CA 1231473 A	12-01-1988
		DE 3370423 D	23-04-1987
		JP 1600727 C	31-01-1991
		JP 2026901 B	13-06-1990
		JP 60003240 A	09-01-1985
US 5757851 A	26-05-1998	JP 2601160 B	16-04-1997
		JP 7123462 A	12-05-1995
		EP 0651523 A	03-05-1995
		KR 150246 B	02-11-1998