

(19) World Intellectual Property
Organization
International Bureau



(43) International Publication Date
18 August 2005 (18.08.2005)

PCT

(10) International Publication Number
WO 2005/076094 A2

(51) International Patent Classification⁷: G05B 19/4099

(21) International Application Number:

PCT/EP2005/000646

(22) International Filing Date: 24 January 2005 (24.01.2005)

(25) Filing Language: English

(26) Publication Language: English

(30) Priority Data:

MI2004A000166 3 February 2004 (03.02.2004) IT

(71) Applicant (for all designated States except US): **FIN-TRADE S.R.L.** [IT/IT]; 60, Via Mazzini, I-25020 Alfianello (IT).

(72) Inventors; and

(75) Inventors/Applicants (for US only): **BERTOLA, Paolo** [IT/IT]; 30, Viale della Vittoria, I- Introbio (IT). **JULITA, Francesca** [IT/IT]; 24, Via Lungo Lario Cadorna, I-22053 Lecco (IT).

(74) Agents: **FERRAILOLO, Ruggero** et al.; Via Napo Torriani, 10, I-20124 Milano (IT).

(81) Designated States (unless otherwise indicated, for every kind of national protection available): AE, AG, AL, AM, AT, AU, AZ, BA, BB, BG, BR, BW, BY, BZ, CA, CH, CN, CO, CR, CU, CZ, DE, DK, DM, DZ, EC, EE, EG, ES, FI, GB, GD, GE, GH, GM, HR, HU, ID, IL, IN, IS, JP, KE, KG, KP, KR, KZ, LC, LK, LR, LS, LT, LU, LV, MA, MD, MG, MK, MN, MW, MX, MZ, NA, NI, NO, NZ, OM, PG, PH, PL, PT, RO, RU, SC, SD, SE, SG, SK, SL, SY, TJ, TM, TN, TR, TT, TZ, UA, UG, US, UZ, VC, VN, YU, ZA, ZM, ZW.

(84) Designated States (unless otherwise indicated, for every kind of regional protection available): ARIPO (BW, GH, GM, KE, LS, MW, MZ, NA, SD, SL, SZ, TZ, UG, ZM, ZW), Eurasian (AM, AZ, BY, KG, KZ, MD, RU, TJ, TM), European (AT, BE, BG, CH, CY, CZ, DE, DK, EE, ES, FI, FR, GB, GR, HU, IE, IS, IT, LT, LU, MC, NL, PL, PT, RO, SE, SI, SK, TR), OAPI (BF, BJ, CF, CG, CI, CM, GA, GN, GQ, GW, ML, MR, NE, SN, TD, TG).

Declaration under Rule 4.17:

— of inventorship (Rule 4.17(iv)) for US only

Published:

— without international search report and to be republished upon receipt of that report

[Continued on next page]

(54) Title: ELECTRONIC PHOTO-OPTICAL SYSTEM FOR SURVEYING, DIGITALIZING AND REPRODUCING THE EXTERNAL SURFACE OF A THREE-DIMENSIONAL OBJECT, EITHER VIRTUALLY OR IN PLASTIC, COMPOSITE OR PAPERY MATERIAL

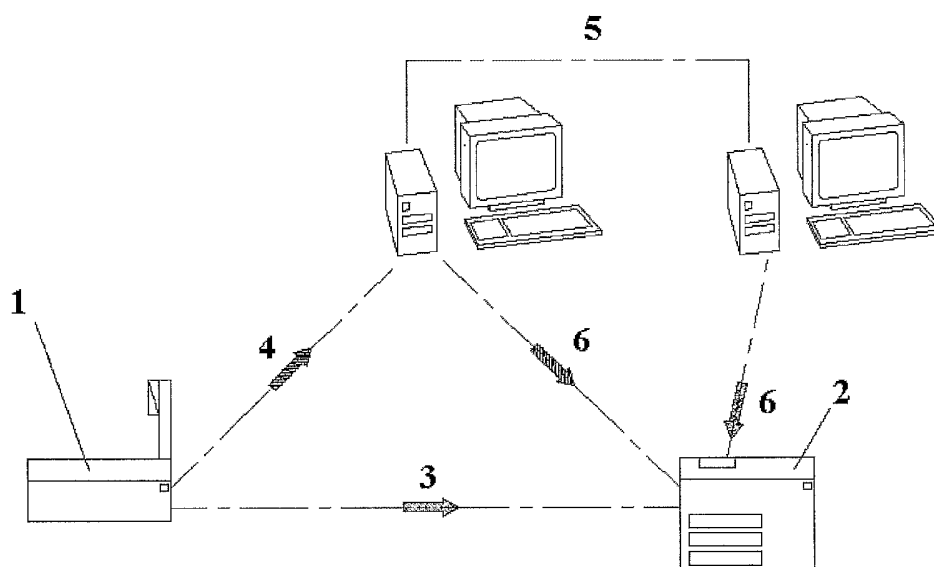

(57) Abstract: The acquisition and reproduction units of the system (1, 2) are interconnected by means of a network (3, 4, 6) in order to survey and regenerate the outline of any kind of object and to reproduce it either virtually in a CAD 3D system or materially in plastic, composite or papery material.

WO 2005/076094 A2



For two-letter codes and other abbreviations, refer to the "Guidance Notes on Codes and Abbreviations" appearing at the beginning of each regular issue of the PCT Gazette.

Electronic photo-optical system for surveying, digitalizing and reproducing the external surface of a three-dimensional object, either virtually or in plastic, composite or papery material.

5

Field of the invention

The present invention relates to an electronic photo-optical system capable of surveying the external outline any kind of object and transform it into a set of Cartesian coordinates (x,y,z) ; transmitting the mathematical data of these geometries via networks both to a personal computer (to realize a three-dimensional graphical representation of the object and render possible the further processing of its geometry by means of three-dimensional, computer-assisted design, CAD 3D) and directly to an on-line device of the fax-reproducer type for the reproduction in plastic, composite or papery material of the volume of the surveyed object, in an automatic manner and in accordance with a predetermined logic, composite material being here understood as referring to a material obtained by the union of at least two components having chemical and physical characteristics such as to render them different, insoluble and capable of being separated from each other.

10
15

Prior art

The prior art relating to the transformation in a personal computer of the outline of any kind of surveyed and digitalized object into the external surface of a three-dimensional (3D) virtual object consists principally of the use of lasers and feelers for determining the space coordinates of the object or three-dimensional reconstruction by means of the acquisition of images from video cameras and video projectors.

20

The prior art relating to the realization of an object in plastic material or other material by means of data obtained from a CAD 3D system comprises principally the

25

- 2 -

use of lasers and milling cutters; rapid prototyping like stereolithography (SLA); laser sintering (SLS); the LOM method; the FDM method, the 3DP method; the SGC method. Furthermore, the prior art comprises the device for thermoforming, digitalizing and reproducing the external surface of an object in three-dimensions, 5 virtually and/or in thermoformable plastic material, object of Italian Patent Application No. MI 2003 A 000177 and International Application No. PCT/EP 04/00855, in which an integrated module for the calculation and management of information technology (IT) data, a scanner module and a reproduction module are capable of thermoforming external surfaces of objects from panels (sheets) of 10 thermoformable plastic material without having to rely on negative or positive moulds, carrying out 3D scannings of pre-existing objects taken as model, translating them into the external surfaces of virtual objects that can be processed by means of CAD 3D programs, carrying out operations of remote reproduction by means of 3D fax of previously digitalized surfaces or surfaces of objects designed by means of 15 CAD 3D and conserved in a data base, in the form of surfaces of objects thermoformed in thermoplastic material.

Disadvantages of the prior art

The disadvantages of the prior art consist of the very considerable sophistication associated with the conventional scanners and 3D reproducers, with 20 consequent high costs of first purchase and maintenance, which relegate these products to a very restricted and very sectorial market area, principally concentrated in the compartment of fast prototyping for mechanical design and architecture.

Description of the invention

The symbols used in the present description are explained in the following 25 Table 1:

Symbol	Description
Dides	Employed roll-type and sheet-type supports specifically formulated to be of the plastic, composite or papery material
3D	Numerical matrix of the Cartesian coordinates of the object obj
3Dc	Numerical matrix associated with the colours of the object obj
3Dr	Numerical matrix of the Cartesian coordinates of the real-scale object obj
3Drr	Numerical matrix describing the geometry of the object obj in the radial system
3Drrt	Numerical matrix describing the geometry of the object obj in the radial system with template-cutting information
c	Centre of rotation of the plane π
C	Colour vector
c1	Centre of the plane $\pi 1$
d	Horizontal distance between the centre c of the base plane (π) and the centre c1 of the reading plane ($\pi 1$)
i, j, k	Indices utilized in the matrix computation
m	Number of divisions along the n^{th} individual profile of the object obj
Mod. A printing	Modality for printing the module VT-MF ^{II} for plastic, composite or papery supports of the sheet-type, operated by logic 3Dr and 3Dc
Mod. B printing	Modality for printing the module VT-MF ^{II} for plastic, composite or papery supports of the roll-type, operated by logic 3Drrt and 3Dc
n	Number of planes utilized for scanning the object obj
N image	Number of images = $t \times nf$
nf	= [images/s]

obj	Object that is being scanned
P	Matrix of the profiles associated with the levels z_i
PC	Personal Computer
P_i	Generic point of the profile of the object obj
R	Rotation matrix of the system
R_g	Winding radius with respect to the axis of rotation
R_{g0}	Radius of the initial axis of rotation
RP_i	Rotation radius described by P_i
S	Thickness of the sheet wound as a spiral around the axis of rotation
S image	Displacement associated with the image N image = $t \times Vz$
Sf	Scale factor matrix
T	Translation matrix from the system $\pi 1$ to the system π
t	Generic instant of film (image) shooting
tg	Cutting information vector
Tr	Total time of film shooting
v	Vertical distance between the centre c of the base plane (π) and the centre c1 of the reading plane ($\pi 1$)
VT^{II}	Electronic photo-optical device for surveying, digitalizing and reproducing in three-dimensions the external surfaces of an object
VT-Data^{II}	Integrated module for mathematically calculating and managing informatics data relating to the external surface of the object obj
VT-MF^{II}	Three-dimensional reproduction module
VT-MS^{II}	Three-dimensional scanner module

V_z	= [mm/s]
x	x -axis of Cartesian reference system placed at the centre c of the plane π
X	X -axis of Cartesian reference system placed at the centre c1 of the plane π1
y	y -axis of Cartesian reference system placed at the centre c of the plane π
Y	Y -axis of Cartesian reference system placed at the centre c1 of the plane π1
z	z -axis of Cartesian reference system placed at the centre c of the plane π
Z	Z -axis of Cartesian reference system placed at the centre c1 of the plane π1
α	Angle of inclination of the plane π1 with respect to the plane π
π	Base plane (plane on which there rests the object obj)
π1	Reading plane (plane in which the images of the object obj are obtained by means of the digital acquisition system)
θ	Winding angle [in degrees]

The device VT^{II} consists of modules interfaced with each other and capable of virtually acquiring and materially reproducing the external surfaces of any kind of object **obj**.

The scanning module VT-MS^{II} acquires the external coordinates of the outlines of the objects **obj** subjected to surveying, translating them into an ordered set of three-dimensional Cartesian coordinates.

This information, ordered into a specific numerical matrix, can be utilized for the purposes of carrying out the following operations:

- a) Reproduction of the object **obj** subjected to scanning in plastic, composite or papery material: direct passage from the scanning module VT-MS^{II} to the reproduction module VT-MF^{II}, without intervention to modify the originally acquired data;
- b) Reproduction of the object **obj** subjected to scanning as view of a 3D virtual object **obj** in a PC: direct passage from the scanning module VT-MS^{II} to a PC to be available for both viewing and modification in a three-dimensional computer-assisted design environment;
- 10 c) Reproduction in plastic, composite or papery material of the object **obj** subjected to scanning and modified in a PC or of a virtual object **obj** designed by means of CAD 3D: direct passage from a PC to reproduction module VT-MF^{II} (**Mod. A printing** and/or **Mod. B printing**).

Informatics interfaces of the following types may be created with the device:

- 15 - type 10/100 ethernet board;
- modem board;
- serial communication port; USB port;
- wireless network transmission board.

These solutions assure every type of dialogue between the systems for data
20 transmission and reception; in particular, using the modem board on the scanning device (VT-MS^{II}) and on the reproduction device (VT-MF^{II}), direct on-line transmission can be realized between the devices (case [a] of the preceding paragraph) and this makes it possible to regard the former as a transmitting fax and the latter as a receiving fax interlinked for automatic
25 reception.

With a view to making full use of the capacities of the module systems of the device VT^{II}, the CAD 3D systems are equipped with specific softwares (VT^{II} softwares) capable of generating files having a format compatible with the reproduction system VT-MF^{II}, thus making possible the three-dimensional reproduction of objects **obj** generated entirely by means of CAD 3D and/or modified by information received from the scanning module VT-MS^{II}.

The electronic photo-optical system VT^{II} for digitalizing and reproducing the outline of an object **obj** in three-dimensions, virtually and/or in plastic, composite or papery material, is characterized in that it comprises:

10 A - Module VT-Data^{II}: integrated mathematical calculation module for managing informatics data that describe the mathematical logic employed by the hardware present in the modules B and C;

B - Module VT-MS^{II}: scanner module for acquisition of the three-dimensional space coordinates of any kind of surface;

15 C - Module VT-MF^{II}: fax-type reproduction module for realizing the three-dimensional outline of scanned surfaces (case B) or of purely virtual surfaces designed in a CAD 3D environment;

said modules being capable of carrying out the operations of:

1 Surveying, by means of a digital photo camera or a digital survey and image acquisition system, the external surface and the associated colour information of any kind of object **obj** subjected to scanning, obtaining the numerical matrix of the space coordinates of the object **obj** of type **3Dr** and type **3Dc**;

2 Generating files compatible with the CAD 3D standards to render the object **obj** that has been scanned and acquired (as in 1 above) visible in a CAD 3D environment by rendering its surfaces, thus making it possible to intervene and process the data to

modify parts of the object **obj** and/or to add some new ones, and eventually, by means of specific VT^{II} drivers, generate the dedicated files that can be directly interpreted by the reproduction module VT-MF^{II};

3 Generating record files to be transferred to the data base of a PC and containing
5 the mathematical data of the numerical matrices **3Dr** and **3Dc** of the scanned object **obj** (as per 1 and 2 above), so that they can subsequently be re-used not only for viewing and/or modification, but also for being sent to the reproduction module VT-MF^{II} for being reproduced;

4 Transferring the mathematical data of the numerical matrices **3Dr**, **3Dr_{rt}** and
10 **3Dc** of the scanned object **obj** (as in 1 above) by means of modem from the scanner module VT-MS^{II} to the reproduction module VT-MF^{II} with a view to realizing the coloured outline of the scanned object **obj** in plastic, composite or papery material of appropriate formulation and creating one or more physical reproductions (**Mod. A printing** and/or **Mod. B printing**);

15 5 Transferring the mathematical data of the numerical matrices **3Dr**, **3Dr_{rt}** and **3Dc** of the scanned object **obj** (as in 1, 2 and 3 above) or of a virtual object **obj** generated by means of a CAD 3D program from the data base of a PC to the reproduction module VT-MF^{II} with a view to realizing the coloured outline of the object **obj** in plastic, composite or papery material of appropriate formulation and creating one
20 or more physical reproductions (**Mod. A printing** and/or **Mod. B printing**).

Advantages of the invention

The advantages of the invented system are as follows:

The scanner module VT-MS^{II} consists of a digital photo camera or a digital survey and image acquisition system of common use, a rotating plane, a LED system mounted
25 on a motor-controlled axis and an integrated hardware part, so that the set of parts

constituting the scanner device gives rise to a component cost that is markedly less than the cost standards associated with present-day three-dimensional scanning equipment.

In constructional terms, the reproduction module VT-MF ^{II} is comparable to the conventional multifunctional printing systems for office use, such as fax, scanner and photocopier. The overall cost of the device VT-MF ^{II} is markedly less than the cost of the present-day rapid prototyping technologies; furthermore, it employs consumption materials (of a plastic, composite or papery nature) that are likewise less costly than the materials (resins, fibres, powders, thermoplastic reagent gels, etc.) employed by the present-day prototyping systems; assuring also the colouring of the reproduced object.

The low cost of the devices and the consumption material, together with the fact that the devices can be interfaced with the external systems, assure that both these devices can be commonly and easily used and render them particularly suitable for an office-type standard with the cost and use requirements peculiar of a consumer-type market.

Embodiments of the invention

Particular embodiments of the invention will now be described in greater detail with the help of the attached diagrammes and drawings, of which:

- Figure 1 schematically illustrates the functioning of the device VT ^{II};
- 20 - Figure 2 illustrates the composition of the planes ($\pi - \pi 1$);
- Figure 3 illustrates the scanning system with the object **obj** in position and the LED beam;
- Figure 4 illustrates the scanning system with the object **obj** in position and a single LED;
- 25 - Figure 5 shows an example of an object **obj** to be subjected to scanning;

- Figure 6 shows the object **obj** subjected to scanning as seen in the planes **xy**, **yz**, **xz**;
- Figure 7 illustrates the composition of a section at level z_i of the object **obj** subjected to scanning;
- 5 - Figure 8 shows the employed sheet specifically formulated to be of the plastic, composite or papery type (module VT-MF^{II}- **Mod. A printing**);
- Figure 9 illustrates the phases of printing – cutting the profile of the outline template – separation of the outline template from the counter-template – activation of the adhesivation – printing the colour on the
10 template profile – positioning on the assembly tray, adhesivation of the sheets – separation of the edge of the sheet-type support (module VT-MF^{II}- **Mod. A printing**);
- Figure 10 is a schematic representation of the scanned and reproduced object **obj** in plastic, composite or papery material (module VT-MF^{II}-
15 **Mod. A printing**);
- Figure 11 is a schematic representation of the scanned object **obj** in the printing phase in the fax device (module VT-MF^{II}- **Mod. A printing**); indicating also the cut-outs for the positioning of the assembly pins, with the cut-outs made so as to be flush with the separation insert of the
20 employed plastic, composite or papery sheet-type support;
- Figure 12 is a schematic representation of the scanned object **obj** in the printing phase in the fax device, indicating also the cut-outs for the positioning of the assembly pins, with the cut-outs made in the plane surface of the employed sheet-type support (module VT-MF^{II}- **Mod. A
25 printing**);

- Figure 13 is a schematic representation of the scanned object **obj** in the printing phase in the fax device in the adhesivation stage of the planes of the sheet-type support processed in accordance with matrix **3Dr** logic (module VT-MF^{II}- **Mod. A printing**);
- 5 - Figure 14 is a schematic representation of the object **obj** in the final assembly phase (module VT-MF^{II}- **Mod. A printing**), with the coupling pins to be inserted into the cavities aligned with each other and distributed along the plane union surface of the parts into which the object **obj** has been decomposed (in accordance with matrix **3Dr** logic);
- 10 - Figure 15 is a schematic representation of the three-dimensional scanning device VT-MS^{II}.
- Figure 16 shows the employed roll-type support specifically formulated to be of the plastic, composite or papery type (module VT-MF^{II}- **Mod. B printing**);
- Figure 17 is a schematic representation of another scanned and reproduced
15 object **obj** in plastic, composite or papery material, as seen in the planes **xy**, **yz**, **xz** (module VT-MF^{II}- **Mod. B printing**).

The manner in which the device VT^{II} functions is schematically illustrated by Figure 1, where the reference number 1 indicates the three-dimensional scanner apparatus VT-MS^{II}, 2 indicates the three-dimensional fax module VT-MF^{II}, 3 indicates
20 the system for transmitting data directly from the module VT-MS^{II} to the module VT-MF^{II}, 4 indicates the system for transmitting data from the module VT-MS^{II} to the PC for processing, 5 indicates the internet/intranet-type dialogue system between personal computers, and 6 indicates the system for transmitting data from the PC to the module VT-MF^{II}.

Figure 2 shows the composition of the planes (π - $\pi 1$), where the reference number 7 indicates the plane π on which there is positioned the object **obj** to be acquired, with reference axes (x,y,z) and centre of rotation **c**, α = angle between the plane π and the plane $\pi 1$, and 8 indicates the image reception plane $\pi 1$, with reference system (X,Y,Z) and centre **c1**, **d** = horizontal distance between **c** and **c1**, **v** = vertical distance between **c** and **c1**.

Figure 3 illustrates the scanning system with the object **obj** in position and the LED beam activated, where the reference number 7 indicates the plane π on which the object **obj** to be acquired is positioned, with reference axes (x,y,z) and centre of rotation **c**, α = angle between plane π and plane $\pi 1$, 8 indicates the image reception plane $\pi 1$, with reference system (X,Y,Z) and centre **c1**, **d** = horizontal distance between **c** and **c1**, **v** = vertical distance between **c** and **c1**, 9 indicates the profile of the section identified by the LED beam associated with the vertical level of the LED as per 11, 10 indicates the activated LED beam, 11 indicates the vertical level of the LED and its projection level, 12 indicates the base plane rotating about the centre **c** as per 7, and 13 indicates the parallel-beam-type observer.

Figure 4 illustrates the scanning system with the object **obj** in position and a single-LED beam activated, where the reference number 7 indicates the plane π on which the object **obj** to be acquired is positioned, with reference axes (x,y,z) and centre of rotation **c**, α = angle between plane π and plane $\pi 1$, 8 indicates the image reception plane $\pi 1$, with reference system (X,Y,Z) and centre **c1**, **d** = horizontal distance between **c** and **c1**, **v** = vertical distance between **c** and **c1**, 9 indicates the profile of the section identified by the LED beam associated with the vertical level of the LED as per 11, 11 indicates the vertical level of the LED and its projection level, 12 indicates the base plane rotating about the centre **c** as per 7, 13 indicates the parallel-beam-type observer,

14 indicates the activated single-LED beam, and 15 indicates the rotating plane, the rotation being continuous and coordinated with the digital survey on the image plane as in Figure 2.

Figure 5 shows an example of an object **obj** to be subjected to scanning, the reference number 16 indicates an example of an object **obj** to be scanned.

Figure 6 shows views of the object **obj** subjected to scanning as seen in the planes **xy**, **yz**, **xz**, where the reference number 17 indicates the views of the object **obj** as seen in the planes **xy**, **yz**, **xz**.

Figure 7 illustrates the composition of a section at level z_i of the object **obj** subjected to scanning, where the reference number 7 indicates the plane π on which the object **obj** to be acquired is positioned, with reference axes **(x,y,z)** and centre of rotation **c**, α = angle between plane π and plane π_1 , 18 indicates the object **obj** sectioned at a level **z** as per 11, 19 indicates the system for composing images with 90° segments, and 20 indicates the recomposition of the scanned profile of the object **obj** with respect to the reference plane **(x,y,z)** as per 7.

Figure 8 shows the employed sheet-type support specifically formulated to be of the, plastic, composite or papery type (module VT-MF^{II}- **Mod. A printing**), with the reference number 21 indicating the format and 22 the specific separation insert.

Figure 9 illustrates the phases of printing – cutting the profile of the outline template – separation of the template from the counter-template – activation of the adhesivation – printing the colour on the template profile – positioning on the assembly tray, adhesivation of the sheets – separation of the edge of the sheet-type support (module VT-MF^{II}- **Mod. A printing**), where the reference number 23 indicates the separation of the counter-template obtained by the cutting of the

support, 24 indicates the colouring of the profile with colour information obtained in accordance with matrix **3Dc** logic.

Figure 10 is a schematic representation of the scanned and reproduced object **obj** in plastic, composite or papery material (module VT-MF^{II}- **Mod. A printing**), where the reference number 25 indicates the composition sequence into which the scanned object **obj** has been subdivided in accordance with matrix **3Dc** logic.

Figure 11 is a schematic representation of the scanned object **obj** in the printing phase in the reproduction device, showing also the cut-outs for the positioning of the assembly pins, with the cut-outs made so as to be flush with the separation insert of the employed plastic, composite or papery sheet-type support (module VT-MF^{II}- **Mod. A printing**); the reference number 26 indicates the cut-out for the coupling pins positioned so as to be flush with the separation insert of the support.

Figure 12 is a schematic representation of the scanned object **obj** in the printing phase in the reproduction device, showing also the cut-outs for the positioning of the assembly pins, with the cut-outs made in the plane surface of the employed sheet-type support (module VT-MF^{II}- **Mod. A printing**); the reference number 26 indicates the cut-out for the coupling pins positioned on the plane surface of the support.

Figure 13 is a schematic representation of the scanned object **obj** in the printing phase in the reproduction device (module VT-MF^{II}- **Mod. A printing**), in the adhesivation stage of the planes of the sheet-type support processed in accordance with matrix **3Dr** logic, the reference number 27 indicates the separation edge of the guide plinth that has to be removed when the reproduced parts are assembled by means of the coupling pins.

Figure 14 is a schematic representation of the object **obj** in the final assembly phase (module VT-MF^{II}- **Mod. A printing**), with the coupling pins to be inserted into

the corresponding cavities aligned with each other and distributed along the plane union surface of the parts into which the object **obj** has been decomposed in accordance with matrix **3Dr** logic, the reference number 16 indicates the object **obj** to be assembled in accordance with matrix **3Dr** logic, 26 indicates the cavities for accommodating the pins, and 28 indicates the coupling pins.

Figure 15 is a schematic representation of the three-dimensional scanning device VT-MS^{II}, where the reference number 1 indicates the scanner device VT-MS^{II}, 7 indicates the rotating plane π on which the object **obj** to be acquired is positioned, with reference axes (x,y,z) and centre of rotation **c**, 8 indicates the image reception plane π_1 , with reference system (X,Y,Z) and centre **c1**, 10 indicates the activated LED beam, 13 indicates the observer/image survey system of the parallel-beam type, 16 indicates object **obj** that is being acquired, and 29 indicates the guides in which the LED system moves along the vertical directrix **z**.

Figure 16 shows the employed roll-type support specifically formulated to be of the plastic, composite or papery type (module VT-MF^{II}- **Mod. B printing**), with the reference number 21 indicating the format and 22 the specific separation insert.

Figure 17 is a schematic representation of another scanned and reproduced object **obj** in plastic, composite or papery material, as seen in the planes **xy**, **yz**, **xz** (module VT-MF^{II}- **Mod. B printing**), the reference number 16 indicates an example of an object **obj** to be scanned and reproduced, 17 indicates the views of the reproduced object **obj** as seen in the planes **xy**, **yz**, **xz**.

Detailed descriptions will now be provided of the following:

1. Integrated module for the mathematical calculation and management of the informatics data (VT-Data^{II});
2. Scanner module (VT-MS^{II})

3. Fax-reproduction module (VT-MF^{II}).

Module VT-Data^{II}:

The operating principle of the electronic photo-optical system VT^{II} for the acquisition of the Cartesian coordinates (x,y,z) of any kind of object **obj** is based on the mathematico-geometrical relationships between the object **obj** and the reference system.

Description of the logic of the reference system:

A. Acquisition of desired Cartesian coordinates (numerical matrices **P**, **3D**, **3Dr** and **3Dc**):

10 a) Given a plane π on which the object **obj** is positioned, let said plane be rotatable about a point **c**, centre of rotation of π , with the axis of rotation perpendicular to the plane;

b) Position of the object **obj** with the condition that at least one point of the object **obj** should form part of the axis of rotation of π passing through **c** (as in [a] above);

15 c) Given a rotation of the plane π and the object **obj** resting on it about the axis of rotation, it follows that each point of the plane and the object **obj** describes a circumference having a radius equal to the distance between the generic point **P_i** and the projection of **P_i** onto the axis of rotation. Let the radius of rotation described by **P_i** be called **RP_i**;

d) Given a second plane π_1 , the exact description of which is defined by the matrix of the direction cosines of π_1 , positioned in space, let us consider the orthogonal projections of the circumferences described by the points **P_i** on π_1 ;

25 e) Since the projection of a circumference onto a non-parallel plane generates an ellipse, one concludes that: an observer at an observation point situated at infinity (i.e.

a parallel-beam-type observer) with respect to the perpendicular passing through π_1 would see the circular motion of the point P_i as an elliptic motion;

f) Let us utilize the rototranslation equations of a reference system with the first system (x,y,z) situated at the centre c of the plane π and the second reference system (X,Y,Z) positioned on the plane π_1 with the directrix Z coincident with the straight line passing through c of π and perpendicular to π_1 (directrix Z coincident with the straight line $c-c_1$);

g) The matrix system associated with the rototranslation makes it possible to define coordinates from the system (x,y,z) to the system (X,Y,Z) and vice versa;

h) The observer at infinity with respect to π_1 , who observes according to (X,Y,Z) , is capable of deducing the exact positions on (x,y,z) by making use of the matrix equations. Given the positions X,Y on (X,Y,Z) and given also the position of the corresponding point z measured with respect to (x,y,z) , the matrix system can be solved.

B. Description of the acquisition of the coordinates $[x,y,z]$:

a) Let the object **obj** be positioned on the base plane (π);

b) The initial position of the object **obj** with respect to the plane (π) and the digital image survey system (π_1) is defined with an angle equal to 0° ;

c) A linear light beam projected parallel to the base plane (π), initially strikes the object **obj** at a position such that $z_1 = \text{vertical level} = 0 + (\text{beam thickness})/2$;

d) The digital image survey system photographs (shoots) the object **obj** and associates the position of angle= 0° and z_1 with this "instant image photogramme/frame";

e) Subsequently the digital image survey system produces a series of n "instant image photogrammes/frames" associated with positions of angle= 0° and z_i with $i = 1: n$ corresponding to the levels $z_i = z_1 + (p \times i)$ for $i = 2 \dots n$, with $p = \text{vertical scanning step}$ (electronically manageable parameter);

- f) Following completion of the sequence at angle=0°, the base plane (π) is made to rotate through angle=90°;
- g) A sequence of n “instant image photogrammes/frames” associated with angle=90°/ z_i is then shot as in (e) above;
- 5 h) Following completion of the sequence at angle=90°, the base plane (π) is made to rotate to angle=180°;
- i) A sequence of n “instant image photogrammes/frames” associated with angle=180°/ z_i is then shot as in (e) above;
- j) Following completion of the sequence at angle=180°, the base plane (π) is made to rotate to angle=270°;
- 10 k) A sequence of n “instant image photogrammes/frames” associated with angle=270°/ z_i is then shot as in (e) above;
- l) For the purposes of composing the 360° closed profile of the object **obj**, let us now consider, for each one of the 4 sequences of n photogrammes/frames of the surveyed digital images (angle=0°, angle=90°, angle=180°, angle=270°), the profile segment equal to 90° calculated on the bisectrix of the angle of incidence as interval – 45°/+45° (Fig. 7);
- m) The composition of the 4 surveyed profile segments is obtained by bringing
- 20 the appropriate profiles back to the plane of angle=0° as follows:
- the profile of angle=90° by changing the coordinates from: x_{90° to y_{0° , and y_{90° to x_{0° ;
 - the profile of angle=180° by changing the coordinates from: x_{180° to x_{0° , and y_{180° to $-y_{0^\circ}$;
 - 25 - the profile of angle=270° by changing the coordinates from:

$x270^\circ$ to $y0^\circ$, and $y270^\circ$ to $-x0^\circ$;

where the coordinates x,y for each system are positioned on the centre of rotation c , evaluated as projection of the incident ray onto the axis of rotation of the base plane π .

C. Data processing modalities:

5 a) Each image photogramme/frame, with which there is associated the angle parameter and the level z , is processed by means of optical filters and/or mathematical operations with a view to showing only the part of the object **obj** struck by the activated LED scanning beam;

b) The image processes as in (a) above is reduced by means of mathematical
10 processing to a matrix of numbers corresponding to the image pixels;

c) The image decomposed in this manner can be associated with the plane coordinate reference system X,Y of which the points highlighted by the light beam represent the profile of the object **obj** projected onto the digital image-shooting plane $\pi 1$;

d) The matrix generated in this manner is of the (0,1) type, such that to each
15 numerical information 1 there corresponds a point of the profile of the object **obj**, and to each numerical information 0 there corresponds everything else; the continuous-line that unites all the points of type 1 corresponds to the profile of the object **obj** (referred to the angle and to z), projected onto the digital image-shooting plane $\pi 1$;

e) Having obtained the image profile associated with the angle and the level z ,
20 the composition of the 90° segments is carried out as in (l) and (m) of paragraph B in the image composition phase (Fig. 7);

f) At the end of the operation one obtains a set of n closed profiles corresponding to the level z_i ; profile is here understood as a set of m coordinates of the type (x_k, y_k, z_i) with k = number of subdivisions of the profile = from 1 to m ; each
25 profile corresponds to a vector of the type m rows, 3 columns $[x,y,z]$;

- g) The composition of all the \mathbf{n} vectors associated with the levels z_i eventually generates the space matrix $\mathbf{3D}$ of type and dimension $\mathbf{3D} = [\mathbf{m} \ \mathbf{n} \ 3]$;
- h) Since the dimension of the matrix that is being acquired is a function of the resolution of the digital image shooting (example 480x640, 1200x600 pixel), a scaling operation is carried out with a view to re-proportioning the horizontal subdivision (640) and the vertical subdivision (480) of the photograph scale to the real dimensions of the field of view, that is to say, given a known horizontal measure on the base plane, everything is re-proportioned to this value; for example: given the known measure of 10 cm on the base plane π corresponding to an interval equal to 400 pixel, to every pixel there corresponds a reading interval equal to $(10 \text{ cm})/400 = 0,4 \text{ cm} = 4 \text{ mm}$; this scaling operation is carried out only once at the end of the computation process by multiplying the matrix $\mathbf{3D}$ by \mathbf{Sf} (\mathbf{Sf} = scale factor matrix), thus obtaining the matrix of the real coordinates of the object $\mathbf{3Dr} = \mathbf{3D} \times \mathbf{Sf}$, still of the type $[\mathbf{m} \ \mathbf{n} \ 3]$ – (module VT-MF^{II} - Mod. A printing);
- i) Generation of the colour information: prior to the digital shooting of every sequence of \mathbf{n} images for the positions angle=0°, angle=90°, angle=180°, angle=270°, there is obtained a digital shot of the object \mathbf{obj} without any position information associated with the activated LED beam; each of the 4 images obtained is defined as a colour sampling image 0°, 90°, 180°, 270°;
- j) The map of profile points identified on the plane π_1 can be associated with the corresponding image points of which the colour information is also known, as in (h) above;
- k) The printing system integrated in the reproduction device VT-MF^{II} utilizes the colour information associated with the points on π_1 , of the type $[\mathbf{X}, \mathbf{Y}, \text{Colour}]$, rectified on the plane π $[\mathbf{x}, \mathbf{y}, \text{Colour}]$.

D. Operation of rectifying the colour of the object **obj**:

a) Association of the coordinates on π_1 with the image colour $3Dc = [X,Y,C]$, where C =number corresponding to the colour, which may be of type: figure comprised between 0 and 255 (information about 256-colour scale), or by using the RGB method with 3 numerical-type information items [0-255,0-255,0-255];

b) Association of the points translated onto the reference system (x,y,z) with the corresponding (X,Y,C) ;

c) Creation of colour curve: the realization of the cutting profile in the reproduction systems VT-MF^{II} (Mod. A printing) utilizes the coordinates of the matrix $3Dr$; for the purpose of colouring the aforesaid profiles, the positions of the points of $3Dr$ are associated with the positions of the matrix $3Dc$ in the following manner: considering the i^{th} profile of $3Dr$ as a vector of type $[x,y,z_i]$ consisting of m rows, the information of $3Dc [X,Y,C]$ with coordinates X,Y is associated with the positions i of the matrix $3D$. With a view to realizing a continuous colour curve, use is made of broken-lines that unite consecutive points by linearly interpolating the known points of (X,Y,C) and real points (x,y,z_i) .

E. Formulation of the matrices P , $3D$, $3Dr$, $3Dc$; the operation is subdivided as follows:

1. Shooting digital image photogrammes/frames on plane π_1 : images taken with the LEDs not activated, for the generation of the colour information: No.4 images corresponding to the positions of the object **obj**: colour sampling image 0° , 90° , 180° , 270° ;

2. Shooting digital image photogrammes/frames on plane π_1 : images shot with the LEDs activated: I_{i,z_i} = acquired image associated with the indices $i = 1:4$

(images at angle=0°, angle=90°, angle=180°, angle=270°), $z_i = 1: n$ (scanning levels);

3. Processing of the images acquired in 1 and 2 above:

a) Processing the images I_{i,z_i} with a colour filter (optical filter or mathematical filter) that brings out only the image portions struck by the activated LED beam;

b) Extraction of the profile matrices P_{i,z_i} with indices $i = 1:4$ (images at angle=0°, angle=90°, angle=180°, angle=270°), $z_i = 1: n$ (scanning levels) containing the profiles, utilizing the pixel position as coordinate system and associating the numerical information 1 with the profile points and the numerical information 0 with all the others; this extraction considers the profile segment corresponding to $-45^\circ/+45^\circ$, valued with respect to the directrix passing through the projection point of the level plane on the axis of rotation of the base plane and the straight line perpendicular to the image plane;

c) Rototranslation of the information from the digital image plane π_1 to the rotating base plane π ; the parameters are defined as:

- d = horizontal measure of the distance between the centre c of the rotating base plane π and the projection of the centre c_1 of the digital image plane π_1 ;
- v = vertical measure of the distance between the centre c of the rotating base plane π and the projection of the centre c_1 of the digital image plane π_1 ;
- $\alpha = \arctan (v/d)$;
- T = vector of the translation coordinates of the Cartesian system from the image base plane: $n = [0 - d \ v]$
- R = rotation matrix of the Cartesian system from the image base plane:

$$\mathbf{R} = \begin{bmatrix} 1 & 0 & 0 \\ 0 & \cos(\alpha - 90^\circ) & \cos(\alpha) \\ 0 & \cos(\alpha - 180^\circ) & \cos(\alpha - 90^\circ) \end{bmatrix}$$

- \mathbf{P} = vector of the coordinates identified on digital image plane π_1 with level Z associated with LED position = $(\mathbf{X}, \mathbf{Y}, \mathbf{Z})$;
 - \mathbf{X} = coordinate points of profile obtained from image;
 - \mathbf{Y} = coordinate points of profile obtained from image;
 - 5 - $\mathbf{Z} = + z * \sin(\alpha) - (\mathbf{Y} - z * \cos(\alpha)) / \tan(\alpha) - (\mathbf{d}^2 + \mathbf{v}^2)^{1/2}$;
 - z = level of the LED position associated with the image.
- F. Rototranslation of the Cartesian system from the plane π_1 to the plane π :
- a) $\mathbf{3D}$ = matrix rototranslated from the plane π_1 to the base plane π ;
 - b) $\mathbf{3D} = [\mathbf{P} - \mathbf{T}] * \mathbf{R}$
- 10 G. Generation of the matrix set $\mathbf{3D}_{rr}$, $\mathbf{3D}_{rrt}$ for the radial coordinates system:
- a) Given the matrices $\mathbf{3D}_r$ and $\mathbf{3D}_c$, let us consider their re-computation in accordance with a new coordinate system of the radial-type. Having defined $\mathbf{3D}_r$ as a matrix of type $[\mathbf{x} \ \mathbf{y} \ \mathbf{z}]$ and the associated matrix $\mathbf{3D}_c$ $[\mathbf{x} \ \mathbf{y} \ \mathbf{C}]$, which has a composition of the type $[\mathbf{x} \ \mathbf{y} \ \mathbf{z} \ \mathbf{C}]$, we can compute the transformation of the Cartesian coordinates from orthogonal to radial in accordance with the following definition:
- $\mathbf{R}_g = \mathbf{R}_g0 + \mathbf{S}/360 * \theta$ = winding radius with respect to the axis of rotation;
 - $\mathbf{R}_g = (\mathbf{x}^2 + \mathbf{y}^2)^{1/2}$;
 - 20 - \mathbf{R}_g0 = initial radius of the axis of the spiral winding;
 - $\theta = (\mathbf{R}_g - \mathbf{R}_g0) * 360 / \mathbf{S}$ = winding angle [in degrees];
 - \mathbf{S} = thickness of the spiral-wound sheet;

b) We now define the matrix describing the geometry of the object **obj** in the radial system as the matrix $3Drr = [Rg \theta z]$ associated with the corresponding matrix $3Dc$ such as compose a space and surface-colour matrix of the type $[Rg \theta z C]$;

5 c) The matrix $3Drr$ makes it possible to construct the volume of the object **obj** on the basis of a spiral-wound axis of rotation having a thickness **S**; the templates to be consecutive cut can be obtained, respectively, from the space confine edges of the matrix set that describes the volume of the object **obj** (module VT-MF^{II} – **Mod. B** printing);

10 d) Given the matrix $3Drr$, the cutting condition **tg** is obtained in accordance with the following logic: given $3Drr = [Rg \theta z]$ ordered in accordance with increasing values θ, z , one defines the information:

$$tg = active = 1 \text{ (when } z_i \neq z_{i+1} \text{)}$$

$$tg = inactive = 0 \text{ (when } z_i = z_{i+1} \text{ Drr)}$$

15 Having composed all the information into the vector **[tg]**, one then composes the new matrix $3Dr rt$:

$$3Dr rt = 3Drr + [tg] = [Rg \theta z tg]$$

In the rectification plane of the spiral, the cutting information vector **[tg]** constitutes the external confine of the object **obj** (module VT-MF^{II}- **Mod. B**
20 **printing**).

Modulo VT-MS^{II}:

The digital photo-optical scanner module VT-MS^{II} is the system that makes possible the acquisition of the data necessary for defining the numerical matrices $3Dr$ and $3Dc$ of the chromatic and space coordinates of the object **obj** and is made up of:

25 1. Rotating base plane on which there are placed the objects **obj** to be surveyed;

2. Digital image survey and acquisition system (photo camera or video camera);
3. System of luminescent LEDs capable of generating a linear light beam projected parallel to the rotating base plane on which the objects **obj** to be surveyed are supported.

5 The following points set out the definition of the characteristics:

- a) The rotating base plane has a rotation pin at its centre, said pin enabling it to rotate through angles comprised between 0° and 360° , the movement may be of the manual rotation type, by mean of adjustment screws or of the motorized type, connected with the data management board;
- 10 b) The digital image survey and acquisition system is arranged such as to confer upon the photo camera or video camera employed the macro-type/parallel beam modality, with a specific angle (α) respect to the base plane (π);
- c) The LED system is situated on the vertical of the digital image acquisition device, it generates a linear light beam projected parallel to the rotating base plane in
15 accordance with predetermined distances and movements that are either stepped or of the continuous, motor-controlled type. The positioning of the light beam is coordinated with the shooting sequence of the image photogrammes/frames, so that a particular position of the projected beam is associated with each acquired image; the LED system is linked to an electronically controlled kinematic mechanism that
20 makes possible a movement in steps determined in accordance with z of the base plane π ; when the images are acquired by means of a digital photo camera, the number of the images in the sequence from 1 to n is associated with the step position of the scanning light beam, i.e. to image 1 there corresponds a displacement step led/1, equal to a known measure that corresponds to the projection of the light beam
25 moved along the extension of the vertical sliding axis of the device, image 2

corresponds to step $led/2$, etc. When the images are acquired by means of a video camera capable of realizing a sequence of nf images per second [images/s] and the LED system is displaced with a continuous-type motion at a speed of Vz [mm/s], the shooting parameters are associated in the following manner: let t be a generic instant of the shooting motion of the digitally acquired photogrammes/frames, measured from the beginning of the motion sequence, as regards the video camera shooting/movement of the LED scanning plane, we define:

- **N image** = image number = $t \times nf$
- **S image** = displacement associated with image **N image** = $t \times Vz$

When the shooting parameters nf and vz are understood in this manner, the level z of the object **obj** subjected to scanning can be defined by subdividing the total shooting time Tr into n steps, such that $t = Tr/n =$ time interval between two consecutive images, i.e. when n is increased, one increases the definition of the numerical matrix **3D**;

d) The hardware integrated in the module envisages the use of the method described in connection with the module VT-Data^{II}, paragraphs (A) to (E).

Module VT-MF^{II}:

The defined reproduction-fax module VT-MF^{II} consists of a printer that makes possible the coloured three-dimensional duplication in plastic, composite or papery material of the external surface of objects **obj** that have been scanned or designed by means of CAD 3D.

This reproduction module provides to printing modalities, namely **Mod. A printing**, operated by means of the logic **3Dr** and **3Dc** when the supports of the plastic, composite or papery type are available in the form of sheets; and **Mod.**

B printing, operated by means of the logic **3Dr_{rt}** and **3Dc** when the supports of the plastic, composite or papery type are available in the form of rolls.

Mod. A printing of the module VT-MF^{II} reproduces the external surface of the object **obj** by processing by means of templating and superposing the plane surfaces
5 (corresponding to the subdivision into parallel layers of the virtual object **obj** to be reproduced, in accordance with matrix **3Dr**) of the chosen and employed supports of the plastic, composite or papery type when they are in the form of sheets (Figure 12).

Mod. B printing of the module VT-MF^{II} reproduces the external surface of the object **obj** by processing by means of templating and winding around an axis of rotation
10 of the continuous surface (corresponding to the subdivision into consecutive spiral-shaped layers of the virtual object **obj** to be reproduced, in accordance with matrix **3Drr**) of the chosen and employed supports of the plastic, composite or papery type when they are in the form of rolls (Figure 17).

Associated with the cutting device of the reproduction module VT-MF^{II} for
15 processing the employed supports of the sheet-type and/or the roll-type (cut management in accordance with VT-Data^{II} logic of type **3Dr** and **3Dr_{rt}**), is a printing device for the coloured reproduction of the external surface of the object **obj** with fidelity to detail and reproduction of the digital photographic type (printer management in accordance with VT-Data^{II} logic of type **3Dc**). Also comprised in the module is the data processing
20 hardware and the system for connecting it to a PC and/or a network, with connection typologies that have already been described hereinabove.

The sequential cutting operation of the plane profiles (VT-MF^{II}- **Mod. A printing**), is contained in the data of the matrix **3Dr**, because this matrix was generated by using the **n** planes of level **z_i** into which the virtual volume of the object **obj** was
25 decomposed; these decomposition planes, which are parallel and adjacent to each other,

correspond physically to the employed supports of the sheet-type with their specific composition and structure of plastic, composite or papery material.

The continuous cutting operation of the spiral-shaped profiles of the angles of revolution paired (VT-MF^{II}- **Mod. B printing**), is contained in the data of the matrix **3Dr**, and envisages the construction of the object **obj** by means of wrapping around an axis of rotation that corresponds to the vertical axis **z** positioned at the centre of the plane π and passing through the object **obj**; the continuous radial-coordinate surface of the object **obj** around this axis of rotation corresponding physically to the employed support of the roll-type having a thickness **S** and composed of plastic, composite or papery material.

The hardware contained in the system of the module VT-MF^{II} assures the decomposition of the matrix **3Dr** into **n** planes and the decomposition of the matrix **3Dr** into **n** spirals (Maximum value of radius= $Rg_{max}=Rg_0 + S/360*\theta_{max}$; $n=\theta_{max}/360$), scaling the resolution and the subdivision of the planes and spirals in accordance with the needs of the user.

The in-the-round construction of the three-dimensional volume of the object **obj** is realized by means of the composition by specific jointing of the sections into which the initial volume of the object **obj** was subdivided and recomposed. This combinatorial property makes it possible to manage the reproduction of the dimensional volume of the object **obj** in a practically unlimited manner, so that there comes into being the possibility of reproducing the outline of any kind of object **obj** in plastic, composite or papery material and with dimensions that are neither restricted nor restricting by means of the subdivision into modular parts of a scale as required by the volume to be realized, previously processed by VT-Data^{II} as numerical matrices **3Dr**, **3Dr** and **3Dc**.

The reproduction module VT-MF^{II} described as fax-receiving apparatus is schematically made up as follows:

- 1) Space in which there are contained the trays on which the use material of the sheet-type is accommodated (**Mod. A printing**);
- 5 2) Space in which there is contained the axis/pin on which the use material of the roll-type is accommodated (**Mod. B printing**);
- 3) System for loading, aligning and predisposing the support of the sheet-type (in plastic, composite or papery material) for the cutting phase (**Mod. A printing**);
- 10 4) System for loading, aligning and predisposing the support of the roll-type (in plastic, composite or papery material) for the cutting phase (**Mod. B printing**);
- 5) Low-power laser cutting system brought into action in accordance with matrix **3Dr** (**Mod. A printing**) and matrix **3Drrt** (**Mod. B printing**);
- 15 6) System for separating the processed support of the sheet-type from its counter-outline (template) - (**Mod. A printing**);
- 7) System for separating the processed support of the roll-type from its counter-outline (template) - (**Mod. B printing**);
- 8) Colour printing system dedicated to the employed support of the sheet-type and the roll-type (in plastic, composite or papery material), brought into action in accordance with matrix **3Dc** (**Mod. A printing** and **Mod. B printing**);
- 20 9) System for activating the obtained surface of the sheet-type (in accordance with the specific characteristics of the employed type of support), for the consequent adhesivation (**Mod. A printing**);
- 25

- 10) System for stacking and compacting the supports of the sheet-type processed (**Mod. A printing**);
- 11) System for compacting the supports of the roll-type processed (**Mod. B printing**).

5 The shaping of the objects **obj** as previously described is carried out with the help of cutting system of the low-power-laser type, the cutting head being electronically managed by the hardware of the module VT-MF^{II} based on information obtained by means of the matrices **3Dr** and **3Dr_{rt}**; these modellings also permit the cutting of particular notches (pin spaces) arranged flush with and/or
10 within the plane surface of the worked support (indicated by 26 in Figure 11) of the specific separation insert of the employed support in plastic, composite or papery material (indicated by 22 in Figure 8) for a predefined, subsequently consecutive series of pre-established planes and spirals of the object **obj** to be reconfigured.

These cut-outs generate the pin spaces utilized for uniting the processed parts
15 of the object **obj**, union that is effected by inserting the corresponding coupling pins, which are of a shape identical with and equivalent to the cut-outs that have been made (indicated by 26 and 28, Figure 14, reproduced with **Mod. A printing** – the position and the number of the pins necessary for joining the decomposed parts of the three-dimensional volume of the objects **obj** to be reconfigured is a function
20 of the previously defined scale size of the objects **obj**).

The system is capable of reproducing the coloration of the outline (template) of the supports made of plastic, composite or papery material produced by both cutting systems of VT-MF^{II} (**Mod. A printing** and **Mod B printing**), with a reproduction fidelity of the digital photography type; coloration corresponding to the **nth** profile colour of the
25 volume of the object **obj** (matrix **3Dc**), where the corresponding colour information is

associated with each profile point and/or defined by the user by means of information transferred from a CAD 3D design.

The plastic, composite or papery materials constituting the various types of supports (sheet-type/**Mod. A printing** and roll-type/**Mod. B printing**) employed by the devices VT-MF^{II} for the realization of the outlines of objects **obj** are standardized as regards shape, perimeter and specific separation insert (indicated by 21 and 22, Figures 8 and 16). Each support typology has specific composition characteristics that envisage its being paired with the appropriate specific material of adhesivation and coloration.

Mod. A printing and **Mod. B printing** phases of the module VT-MF^{II} can be described as follows:

1. Loading of the plastic, composite or papery support of the sheet-type from its feeder contained onto the cutting base plane (**Mod. A printing**);
2. Loading of the plastic, composite or papery support of the roll-type from its axis/pin contained onto the cutting base plane (**Mod. B printing**);
3. Sequential cutting of the n^{th} profile plane into which the object **obj** has been subdivided by mean of matrix **3Dr** (**Mod. A printing**), and separation of the positive templates (outlines) obtained from theirs correspondingly generated negative counter-templates;
4. Continuous cutting of the n^{th} angles of revolution paired into which the object **obj** has been subdivided by mean of matrix **3Dr_{rt}** (**Mod. B printing**), and separation of the positive templates (outlines) obtained from theirs correspondingly generated negative counter-templates;
5. Colour printing by means of an inkjet system or a specific system compatible with the employed sheets of a plastic, composite or papery type, in accordance with matrix **3Dc** (**Mod. A printing**);

6. Colour printing by means of an inkjet system or a specific system compatible with the employed rolls of a plastic, composite or papery type, in accordance with matrix 3Dc logic (**Mod. B printing**);
7. Sensitization and activation of the processed support of the sheet-type for adhesivation in accordance with the specific characteristics of the employed plastic, composite or papery material (**Mod. A printing**) processed as 1, 3 and 5 above;
8. Position of the processed support of the sheet-type on the stacking tray to receive the subsequent supports of the sheet-type processed as in 1, 3, 5 and 7 above (**Mod. A printing**);
9. Compaction of the supports of the sheet-type, processed as in 1, 3, 5; 7 and 8 above, by means of consecutive adhesivation of the step-by-step type and final fixing, in accordance with the specific characteristics of the employed material (**Mod. A printing**);
10. Compaction of the supports of roll-type, processed as in 2, 4 and 6 above, by means of consecutive adhesivation in accordance with the specific characteristics of the employed material (**Mod. B printing**);
11. (The presence in the module VT-MF ^{II} of a printing head makes it possible for the machine to operate also as a simple fax device in common use, drawing the common paper to be employed for this purpose from an attached dedicate store).

The final three-dimensional configuration of the object **obj** acquired from the scanner module VT-MS ^{II} and/or generated in a PC by means of CAD 3D design that is to be reproduced by means of the reproduction module VT-MF ^{II} in plastic, composite or papery material is obtained from the combination by jointing and

blockage of the shaped pieces of the sheet-type and/or the roll-type by means of the joints assured by the coupling pins inserted in the generated cavities corresponding to them made on the supports in accordance with the enounced logic, these cavities being specular and perfectly aligned.

- 5 These shaped and jointed pieces, which determine the sectioned parts of the volume of the object **obj** to be recomposed, are coloured in accordance with the enounced logic and a chromaticity and tonal gradation corresponding to the real colour of the surface of the object **obj** subjected to scanning, with a reproduction fidelity of the digital photography type for both **Mod. A printing** and **Mod. B**
- 10 **printing** modalities.

Claims

1. An electronic photo-optical system for surveying, digitalizing and reproducing the external surface of a three-dimensional object, virtually or in plastic, composite or papery material, comprising an integrated module for calculating and managing informatics data, a scanner module and a reproduction module, characterized in that said integrated calculation module (VT-Data ^{II}) describes the mathematical logic utilized in the hardware in the scanner module (VT-MS ^{II}) and the reproduction module (VT-MF ^{II}) and carries out the operations of:

i) surveying, by means of a digital photo camera or a digital image survey and acquisition system, an image sequence of the object to be acquired associated with a consecutive and synchronized sequential projection, positioned and moved in predetermined steps, of a linear light beam projected parallel to the plane (x,y) on which the object is placed and striking the surface of the object to be surveyed;

ii) processing the information acquired as in i) above and reproducing the mathematics that describe the geometry of the external surface of the acquired object taken as model, generating the space coordinates of said object in accordance with a Cartesian reference system with three axes (x,y,z) as logic of the integrated calculation model (VT-Data ^{II});

iii) transferring the mathematical data acquired as in i) and ii) above to a PC for a virtual reproduction of the acquired object; rendering it available by means of specific software to the CAD 3D systems in order to be able to carry out modification interventions;

iv) transferring to a remote station the mathematical data acquired as in i), ii) and iii) above in order to reproduce there by means of reproduction module (VT-MF ^{II}) a copy in plastic, composite or papery material of the external surface of the object

acquired by the scanner module (VT-MS^{II}) or the external surface of a PC-generated virtual object transferred by means of specific software from a CAD 3D file to a **3Dr**, **3Dr_{rt}** and **3Dc**-type data file, in accordance with the logic indicated by the integrated calculation module (VT-Data^{II});

- 5 v) colour printing the external surface of the object to be reproduced in plastic, composite or papery material by using the **3Dc**-type data file format, in accordance with the logic indicated by the integrated calculation module (VT-Data^{II}).

2. An electronic photo-optical system in accordance with Claim 1, characterized in that the integrated informatics data calculation and management module (VT-Data^{II})
10 generates, starting from information obtained from digital images, a numerical matrix **3Dr** representing the coordinates (x,y,z) of the external surface of an object to be calculated; a numerical matrix **3Dc** representing the colour coordinates of said object subjected to scanning; a second matrix set **3D_{rr}**, **3D_{rrt}** obtained by a **3Dr** re-computation in accordance with a radial-type coordinate; the matrices computation being
15 the result of the following passages:

- the data are acquired by using the rototranslation equations of the Cartesian reference system with axes (x,y,z) positioned at the centre **c** of the plane π and the second reference system (X,Y,Z) positioned at the centre **c1** of the plane $\pi1$; the directrix **Z** coinciding with the straight line through the points **c** of π and **c1** of $\pi1$ and
20 with the focal direction of the parallel-beam digital photo-electric apparatus employed for acquiring the images; the object to be scanned being placed on the plane π and the digital image survey device being situated on the plane $\pi1$, the planes π and $\pi1$ being translated and inclined with respect to each other and the equation representing their relationship being **3D** such that:

25

$$\mathbf{3D} = [\mathbf{P} - \mathbf{T}] * \mathbf{R}$$

- **R** = rotation matrix of the Cartesian system from the image base plane:

$$\mathbf{R} = \begin{bmatrix} 1 & 0 & 0 \\ 0 & \cos(\alpha - 90^\circ) & \cos(\alpha) \\ 0 & \cos(\alpha - 180^\circ) & \cos(\alpha - 90^\circ) \end{bmatrix}$$

- **P** = vector of the coordinates identified on image plane π_1 with level **Z** associated with LED position = (**X**,**Y**,**Z**);
- 5 - **X** = coordinate points of profile obtained from image;
- **Y** = coordinate points of profile obtained from image; ;
- $\mathbf{Z} = + z * \sin(\alpha) - (\mathbf{Y} - z * \cos(\alpha)) / \tan(\alpha) - (\mathbf{d}^2 + \mathbf{v}^2)^{1/2}$;
- **z** = level of the LED position associated with the image;
- **T** = vector of the translation coordinates of the Cartesian system of the image
- 10 base plane: $\mathbf{T} = [0 \ -\mathbf{d} \ \mathbf{v}]$;
- **d** = horizontal measure of the distance between the centre **c** of the plane π and the projection of the centre **c1** of the plane π_1 ;
- **v** = vertical measure of the distance between the centre **c** of the plane π and the projection of the centre **c1** of the plane π_1 ;
- 15 - $\alpha = \arctan(\mathbf{v}/\mathbf{d})$;
- generation of the matrix set for the radial coordinate system: given the matrices **3Dr**, **3Dc**, let us consider their re-computation in accordance with a new coordinate system of the radial type. Having defined **3Dr** as a matrix of type [**x y z**] and the associated matrix **3Dc** [**x y C**], which has a composition of the type [**x y z C**], we can
- 20 compute the transformation of the Cartesian coordinates from orthogonal to radial in accordance with the following definition:
- $\mathbf{Rg} = \mathbf{Rg0} + \mathbf{S}/360 * \theta =$ winding radium with respect to the axis of rotation

- $Rg = (x^2 + y^2)^{1/2}$
- $Rg0$ = initial radius of the axis of the spiral winding
- $\theta = (Rg - Rg0) * 360 / S$ = winding angle [in degrees]
- S = thickness of the spiral-wound sheet

5 - we now define the matrix describing the geometry of the object **obj** in the radial system as the matrix $3Drr = [Rg \ \theta \ z]$ associated with the corresponding matrix $3Dc$ such as compose a space and surface-colour matrix of the type $[Rg \ \theta \ z \ C]$; the matrix $3Drr$ makes it possible to construct the volume of the object on the basis of a spiral-wound axis of rotation having a thickness S ; the templates to be consecutive cut
10 can be obtained, respectively, from the space confine edges of the matrix set that describes the volume of the object; given the matrix $3Drr$, the cutting condition **tg** is obtained in accordance with the following logic: given $3Drr = [Rg \ \theta \ z]$ ordered in accordance with increasing values θ, z , one defines the information:

- **tg** = active = 1 (when $z_i \neq z_{i+1}$)

15 - **tg** = inactive = 0 (when $z_i = z_{i+1}$ Drr)

- having composed all the information into the vector **[tg]**, one then composes

the new matrix $3Drtr$:

- $3Drtr = 3Drr + [tg] = [Rg \ \theta \ z \ tg]$;

- thus, the object to be scanned, placed on the plane π in a first position

20 defined as angle 0° with respect to the axis perpendicular to the plane π passing through its centre **c**, is struck by an LED light beam situated at a vertical level **z** with respect to the plane π and the digital photo-electric system of the parallel-beam type employed for the acquisition of the images, corresponding to the plane π_1 , sees the scanned object struck by the LED light beam with which there is associated the
25 vertical level **z**; the digital photo-electric system surveys all the images of the object

in the angle 0° position at the various vertical levels comprised between $z=0$ and the height of the object by means of its subdivision into n parts, subsequently repeating the same operations for the rotations of the object into angular positions of 90° , 180° , 270° on the plane π with respect to the angle 0° of $\pi 1$; the acquired images, translated into numerical matrices, having dimensions corresponding to the number of pixels utilized by the chosen format in the digital image acquisition system with numerical values corresponding to the real colour of the surveyed object, each acquired image being translated into a numerical matrix, while only the colour pixels struck by the LED beam are mathematically selected, converting these pixel positions into the numerical value 1 and associating the numerical value 0 with the remaining image pixels not struck by the beam, the matrices recomputed in this manner having dimensions corresponding to the number of image pixels, according to the horizontal and vertical directions, of which the positions of numerical value 1 correspond to the profiles associated with the vertical levels z , of these profiles there being furthermore considered a radial segment corresponding to $-45^\circ/+45^\circ$ with respect to the reference angle (0° , 90° , 180° e 270°) and subsequently recomposed into 90° segments ($-45^\circ/+45^\circ$) until they describe a complete 360° profile; all this complete profile information, forming part of the plane $\pi 1$ with reference system (X,Y,Z) and associated with the n vertical levels, being translated into the reference system (x,y,z) by means of said rototranslation matrix, of which the final result represents the surface of the scanned object in Cartesian coordinates, i.e. the matrix $3D$, which is subsequently multiplied by the scale factor Sf that reproporitions all the information to the real scale of the acquired object, obtaining the numerical matrix $3Dr = 3D \times Sf$, the generation of the colour information being carried out by utilizing four images at rotation angles 0° , 90° , 180° , 270° , images acquired without the LED

beam projected, and subsequently recomposed into 90° segments by utilizing segments of $-45^\circ/+45^\circ$ relative to the reference positions of the angles 0° , 90° , 180° , 270° , all the information assembled in this manner being translated into a numerical matrix **3Dc** in which the point represent the pixel position information and the corresponding colour number, which may be of the type of a 256-colour scale [0-255], or of the RGB type [0-255/0-255/0-255], the pixel positions of this matrix **3Dc** corresponding to the respective positions of the numerical coordinate matrix **3D**;

3. An electronic photo-optical system in accordance with Claims 1 and 2, characterized in that the integrated module for the mathematical calculation and management of the informatics data (VT-Data ^{II}) carries out the operations of:

- formulating (defining) the parameters for the acquisition of the information needed by the integrated calculation module (VT-Data ^{II}) for ordering the numerical matrices **3D**, **3Dr**, **3Dc**, i.e. formulating the resolution of the digital image survey system and the dimensional level parameter on the z-axis associated with the motion of the continuous or step-by-step type of a plane of the scanning light beam projected parallel to the base plane;
- acquiring the data relating to the external surface of a pre-existing object taken as model and subjected to scanning;
- mathematically processing the acquired data, translating them into Cartesian coordinates and generating a data file (numerical matrices **3D**, **3Dr**, **3Drr**, **3Drrt**, **3Dc**);
- managing the whole of the data by means of a dedicated software;
- managing the data by means of a hardware capable of acquiring and processing data at a high speed and a user interface software, the hardware may be integrated into the mother board of the modules VT-MS ^{II}, VT-MF ^{II} with specific VT ^{II} softwares;

- utilizing the numerical matrix **3Dr** for interfacing, by means of translation into CAD 3D format, with the three-dimensional formats of the CAD 3D systems;
 - using the external geometry acquired object available to CAD 3D in order to make it possible for a rendering of the surface to be presented in a PC;
 - 5 - importing data relating to the surfaces of objects from CAD 3D systems, translating them into the specific coordinate of the orthogonal and radial-type format system of the device (matrices **3Dr**, **3Drr**, **3Drrt** and **3Dc**);
 - processing the data files by scaling the dimensions of the object either directly as desired and/or modifying them by means of the CAD 3D import-export system;
 - 10 - utilizing the numerical matrices **3Dr**, **3Drrt** and **3Dc**, obtained by acquisition or by import from CAD 3D, for the transmission of the data to the reproduction module VT-MF^{II} either locally and/or by means of a network, wireless system and/or a direct telephone line to a remote station;
 - by means of the specific coordinate format system: orthogonal type format
 - 15 and/or radial type format (refer to matrices **3Dr**, **3Drrt** and **3Dc**), reproducing the volume of the object in plastic, composite and papery material and reproducing the corresponding colour with a fidelity of the digital photography type.
4. An electronic photo-optical system in accordance with Claims 1, 2 and 3, characterized in that the scanner module (VT-MS^{II}) carries out the operations of:
- 20 - surveying and acquiring digital images or digital photogrammes/frames of any kind of object in predetermined angular positions; surveying and acquiring digital images or digital photogrammes/frames of the predetermined sequentially stepped positions of a plane of a LED-type light beam that is projected parallel to the base plane on which the object subjected to scanning is placed and strikes said
 - 25 object, associating with this predefined sequential projection active along the

image-shooting field of the employed digital system a synchronized motion such that this motion can be either continuous or made up of predetermined steps; in the case of continuous motion there is associated a video camera shot such as to obtain correspondence between photogrammes/frames and displacements in each unit of
5 time, the photogrammes/frames and displacements coinciding with predefined and therefore known plane measures; when the motion is stepped, with each predefined position of the plane of the scanning beam there is associated the corresponding image obtained by the photo camera;

- providing, by means of digital acquisition, the data needed for the
10 computation of the numerical matrices of the space coordinates $3D_r$ and its corresponding colour matrix $3D_c$ in accordance with said logic (VT-Data II):

5. An electronic photo-optical system in accordance with Claims 1, 2, 3 and 4, characterized in that the scanner module (VT-MS II) comprises:

- a digital photo camera or a digital surveying and image acquisition system
15 placed such as to have image-shooting plane with a photographic system of the macro type, i.e. with parallel beams, and with the inclination of the shooting plane regulated in accordance with predefined angular position with respect to the framed rotating base plane;

- an LED system positioned on the vertical of the digital image-shooting
20 device capable of generating a linear chromatic light beam projected parallel to the rotating base plane carrying the object to be scanned; the light beam is moved in coordination with stepped or continuous motion sequence of the employed digital image-shooting system, so that with each acquired image there is associated also the position with respect to the base plane of the projected light beam striking the
25 object, i.e. the distance between the plane and the beam.

6. An electronic photo-optical system in accordance with Claims 1, 2, 3, 4 and 5, characterized in that the reproduction module (VT-MF^{II}) carries out the operations of:

- reproducing and colouring in plastic, composite and papery material of the sheet-type, the external surface of a virtual object ordered by the orthogonal-type format numerical matrices **3Dr** and **3Dc** of the integrated calculation module (VT-Data^{II}), as per Claims 1, 2 and 3;

- reproducing and colouring in plastic, composite and papery material of the roll-type, the external surface of a virtual object ordered by the radial-type format numerical matrices **3Dr_{rt}** and **3Dc** of the integrated calculation module (VT-Data^{II});

10 - for the sheet-type support: sequentially cutting the profiles of the object to be reproduced in the **n** planes of which it is composed, corresponding materially to employed reproduction supports of a plastic, composite or papery type, said cutting operation being contained in the data of the matrix **3Dr**, because the **n** planes of level **z_i** of the volume of the object were utilized for generating this matrix; the hardware
15 contained in the module system assures the decomposition of the matrix **3Dr** into the **n** planes, scaling the resolution as desired and the subdivision of the planes in accordance with the needs of the user;

- for the roll-type support: continuous cutting the profiles of the object to be reproduced in the **n** spiral-wound planes of which it is composed, corresponding
20 materially to employed reproduction supports of a plastic, composite or papery type, said cutting operation being contained in the data of the matrix **3Dr_{rt}**; the hardware contained in the module system assures the decomposition of the matrix **3Dr_{rt}** into the **n** planes wound as a spiral around the axis rotation, and desired scaling resolution.

7. An electronic photo-optical system (VT-MF^{II}) in accordance with Claims 1, 2,
25 3, 4, 5 and 6, characterized in that it comprises:

- 43 -

- a space in which there are contained the trays in which the use material of sheet-type is stored;
 - a space in which there is contained the axis/pin in which the use material of roll-type is stored;
 - 5 - a system for loading, aligning and predisposing the chosen plastic, composite or papery support of sheet-type for the cutting phase;
 - a system for loading, aligning and predisposing the chosen plastic, composite or papery support of roll-type for the cutting phase;
 - a low-power laser cutting system brought into action in accordance with
10 matrices **3Dr** and **3Dr_{rt}** logic;
 - a colour-printing system dedicated to the chosen plastic, composite or papery support, brought into action in accordance with matrix **3Dc** logic using **3Dr** data for the sheet-type and **3D_{rr}** data for the roll-type;
 - a system for sensitizing the processed surface for the subsequent phase of
15 specific adhesivation for the sheet-type support employed;
 - a system for stacking and compacting the sheet-type supports processed as indicated above;
 - a fax-type printing head in common use.
8. An electronic photo-optical system (VT-MF^{II}) in accordance with Claims 1 to
20 7, characterized in that it carries out the following operations:
- loading the plastic, composite or papery sheet-type support from its feeder-tray onto the cutting base plane;
 - loading the plastic, composite or papery roll-type support from its axis/pin onto the cutting base plane;

25

- cutting the n^{th} plane profile into which the object has been subdivided in accordance with matrix **3Dr** logic, and separation of the positive outline-template thus obtained from the corresponding negative counter-template for sheet-type support;
- cutting the n^{th} spiral-wound profile into which the object has been subdivided
5 in accordance with matrix **3Dr_{rt}** logic for roll-type support;
- colour-printing by means of an inkjet system or a system compatible with the employed plastic, composite or papery supports in accordance with matrix **3Dc** matrix according with **3Dr** logic for the sheet-type supports and according with **3D_{rr}** logic for the roll-type supports;
- 10 - sensitisation and activation of the processed of the sheet-type support for adhesion in accordance with the specific characteristics of the employed plastic, composite or papery material;
- positioning of the shaped sheet-type support on the specific stacking tray for receiving the subsequent supports processed as indicated above;
- 15 - compaction of the sheet-type supports processed as indicated above, effected by means of consecutive adhesion of the step-by-step type and with fixing and assembly of the final supports in accordance with the specific characteristics of the employed material;
- three-dimensional in-the-round configuration of the acquired object by means
20 of specific jointing of the sheet-type and the roll-type supports processed as indicated above, coupling the coloured sections of the volume of the object by means of coupling pins inserted in the corresponding cavities generated in accordance the enounced logic, this combinatorial property making it possible to manage in an unlimited manner the dimensional size of the object to be reproduced by means of the re-proportioning, the
25 decomposition and the reconfiguration into an arbitrary number of coloured sections of

the object or the objects to be reproduced, previously processed in accordance with the logic indicated by VT-Data ^{II}.

9) An electronic photo-optical system in accordance with Claims 1 to 8, wherein the sheet-type and the roll-type supports that reproduce and realize outlines of objects
5 subjected to scanning or obtained from a CAD 3D design (system) are characterized in that they are made of plastic, composite or papery material, are standardized as regards form, perimeter and separation inserts suitable for separating the guide edge of the processed outline template in accordance with said logic and are dedicated and specific
10 in accordance with the typology of the employed material; each sheet-type and roll-type supports having specific characteristics that pair them with the corresponding colouring material, the shaping ordered in accordance with matrices **3Dr** and **3Dr_{rr}**, logic also assuring the cutting of particular cavities at the base of some sections of the object to be reconfigured, incisions that generate the pin spaces or cavities utilized for uniting the processed parts of the object by means of specific insertion and coupling pins having
15 outlines equal to the cut cavities, the position and the number of the pins needed for a coupling being a function of the dimensions of the object to be reproduced, and the colouring of the sheet-type and roll-type supports being carried out in accordance with the colour information received from the matrix **3Dc**, in which each matrices **3Dr** and **3Dr_{rr}** have associated with it the colouration of the desired object that reproduces the
20 chromaticity with reproduction of the digital photography type of the object in accordance with the image acquired or defined by the user by means of information transferred from a CAD 3D system.

10) Electronic photo-optical system for surveying, digitalizing and reproducing the external surface of a three-dimensional object, either virtually or in plastic,
25 composite or papery material.

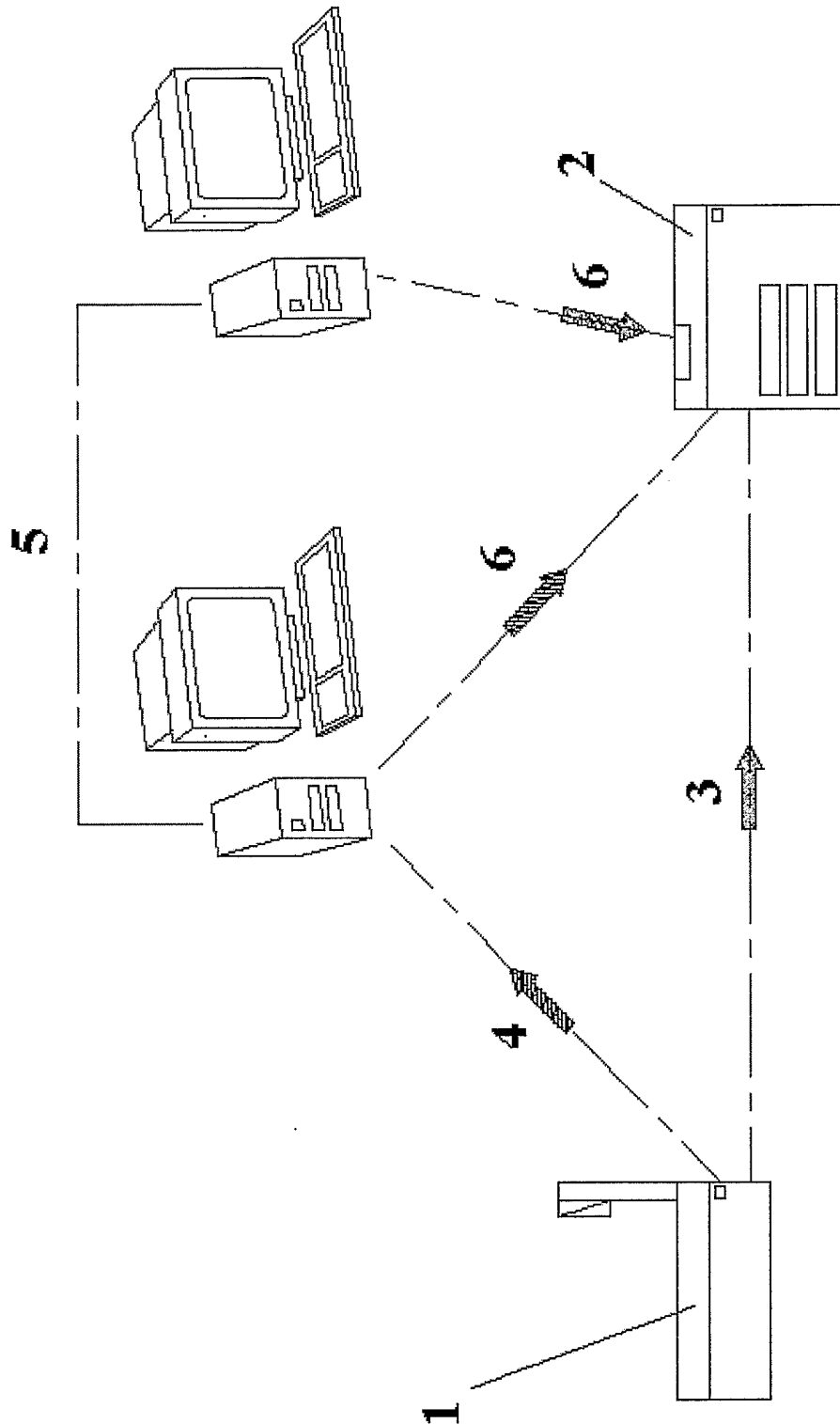

FIG. 1

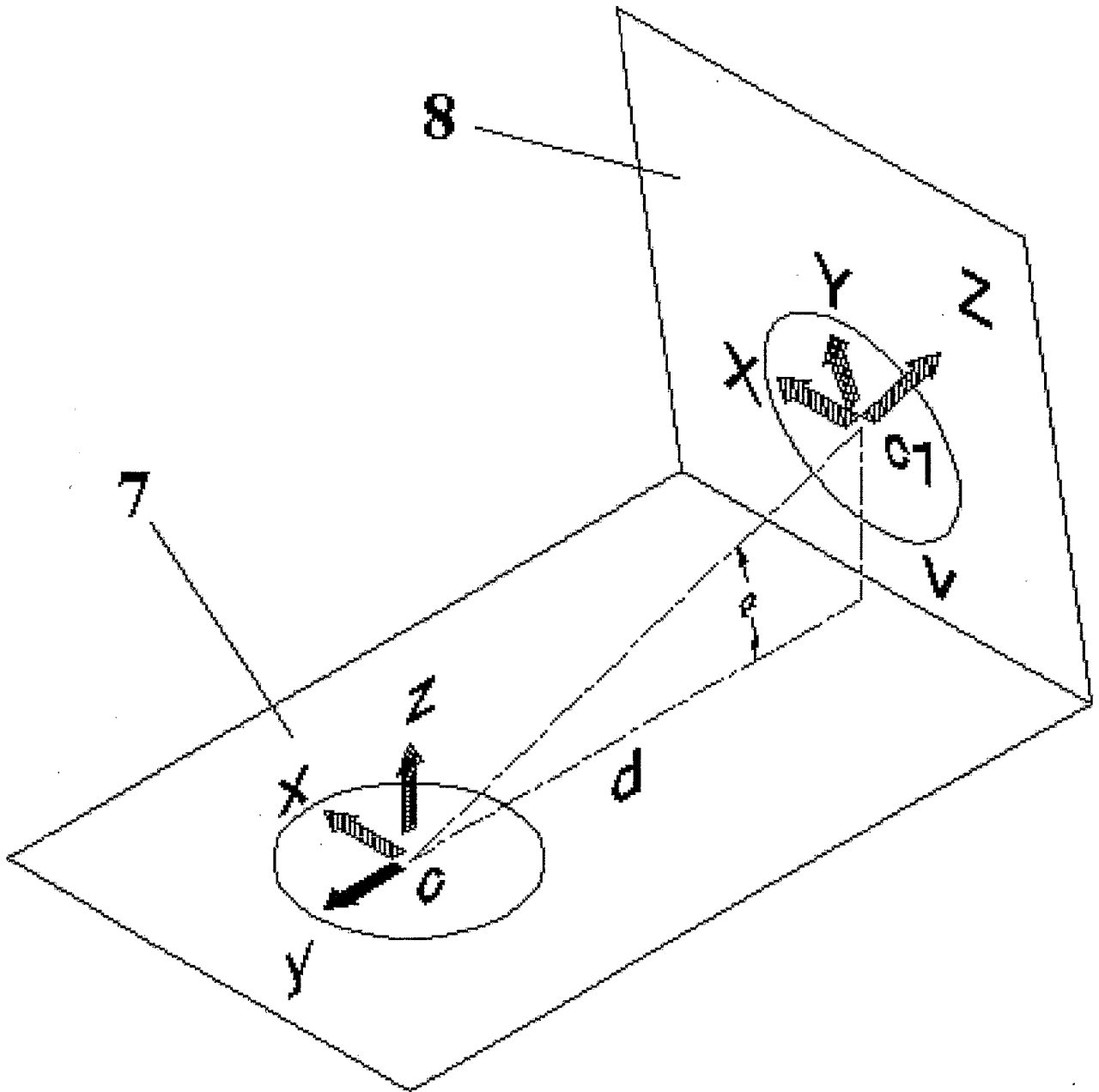

FIG. 2

3/12

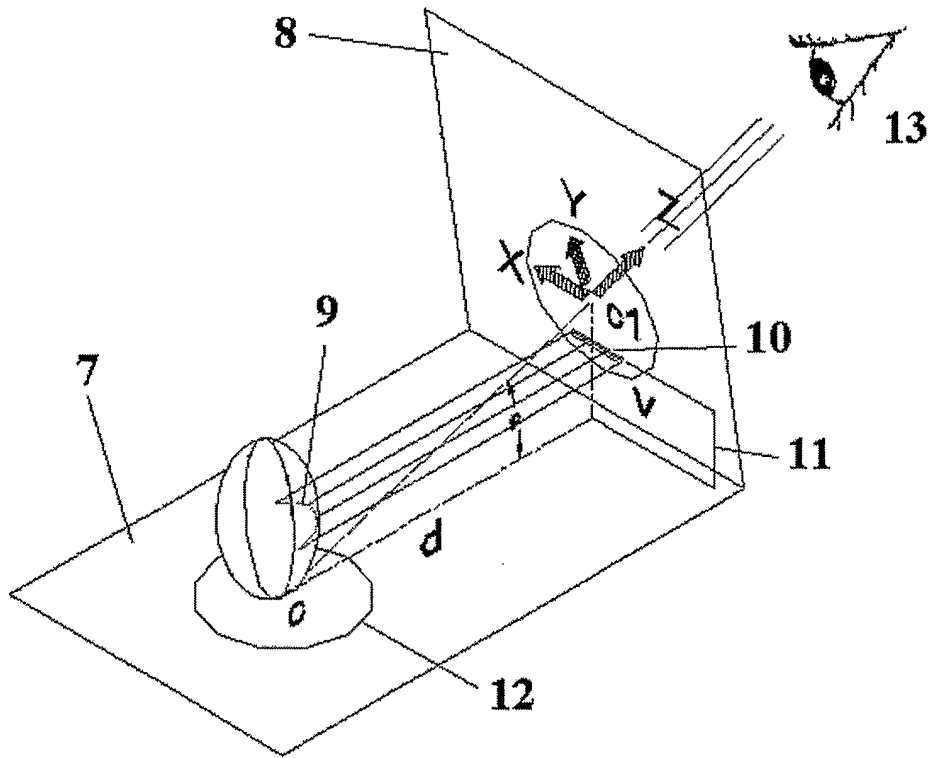

FIG. 3

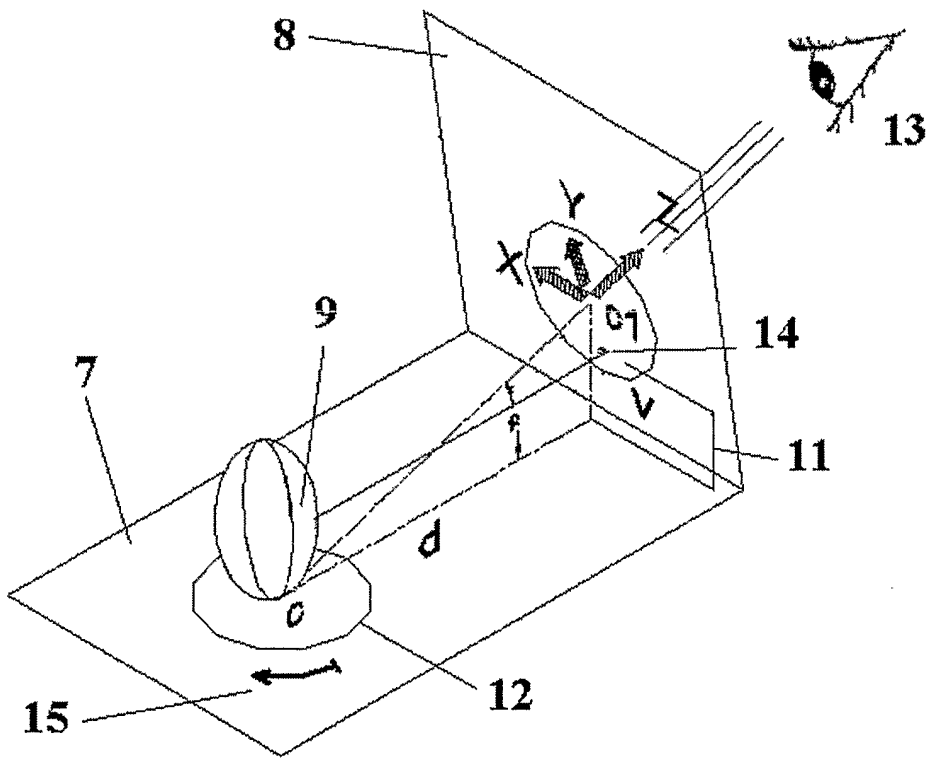

FIG. 4

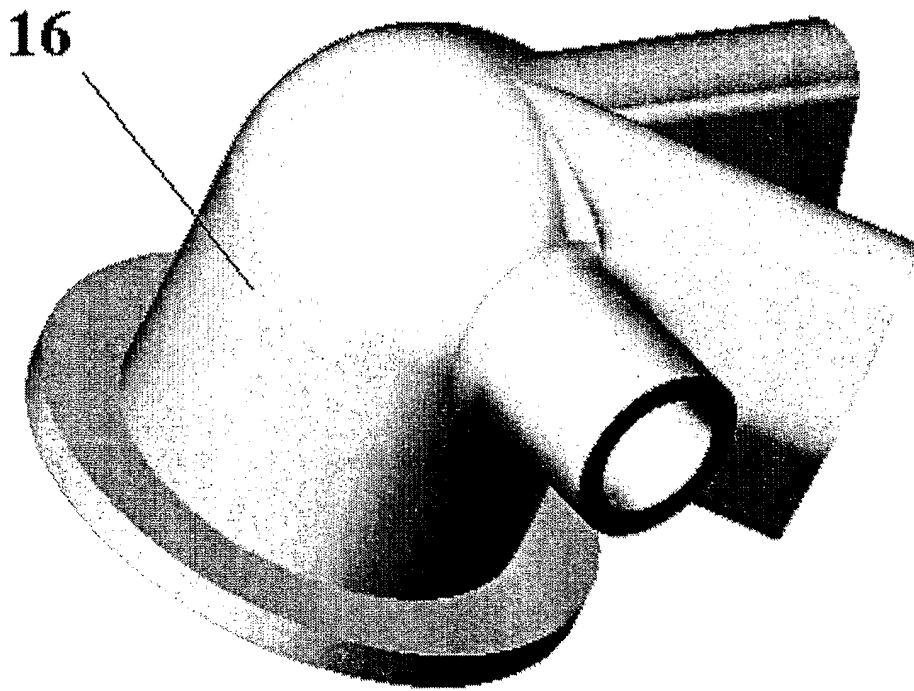

FIG. 5

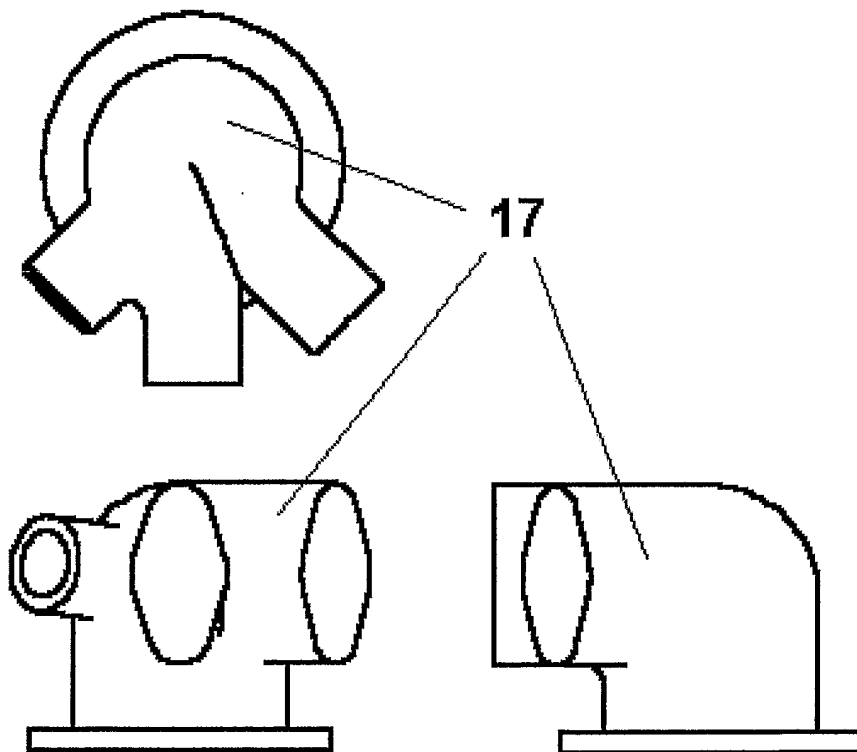

FIG. 6

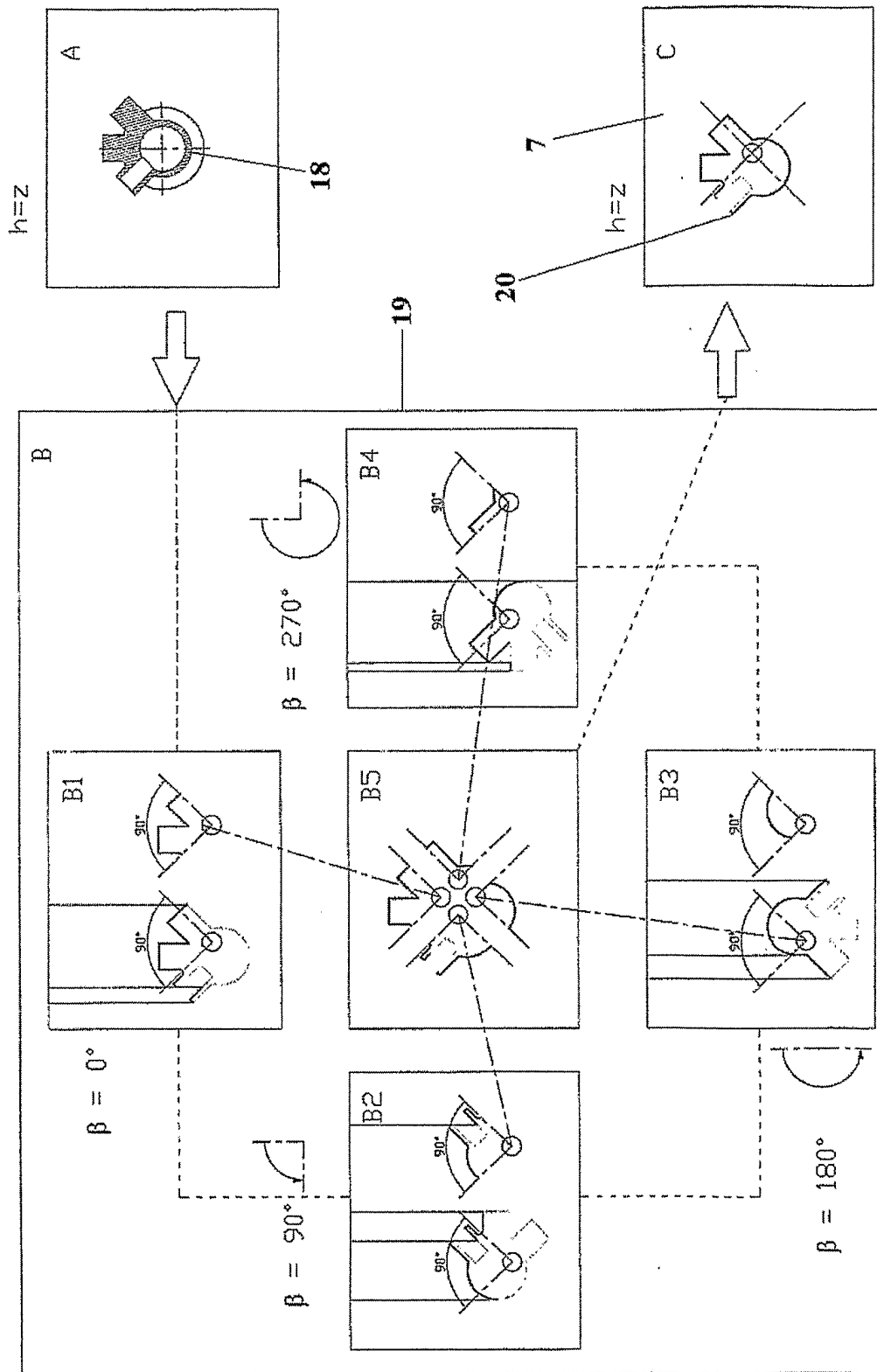

FIG. 7

6/12

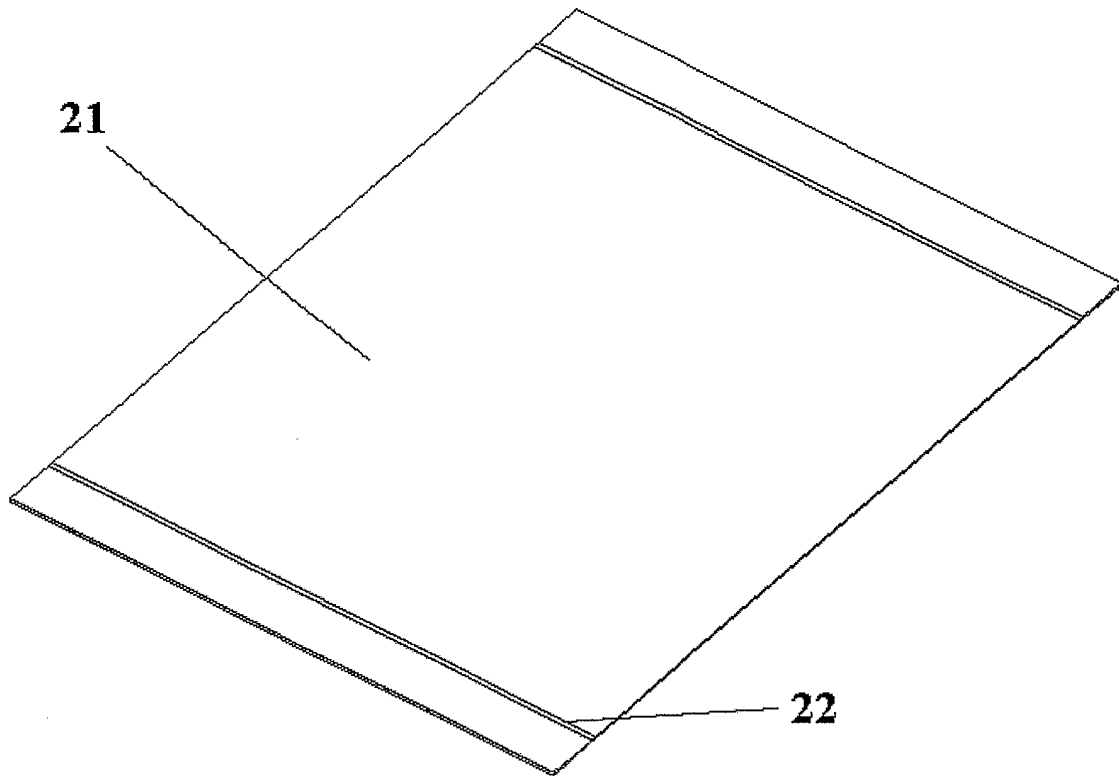

FIG. 8

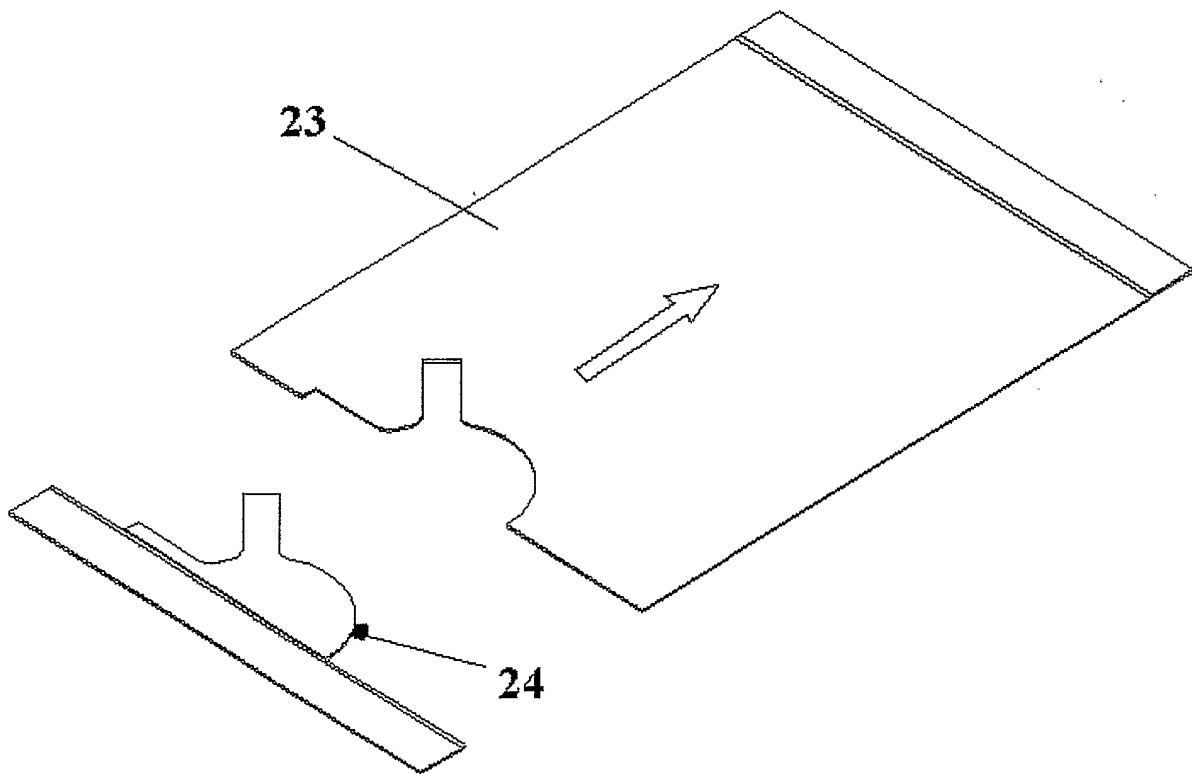

FIG. 9

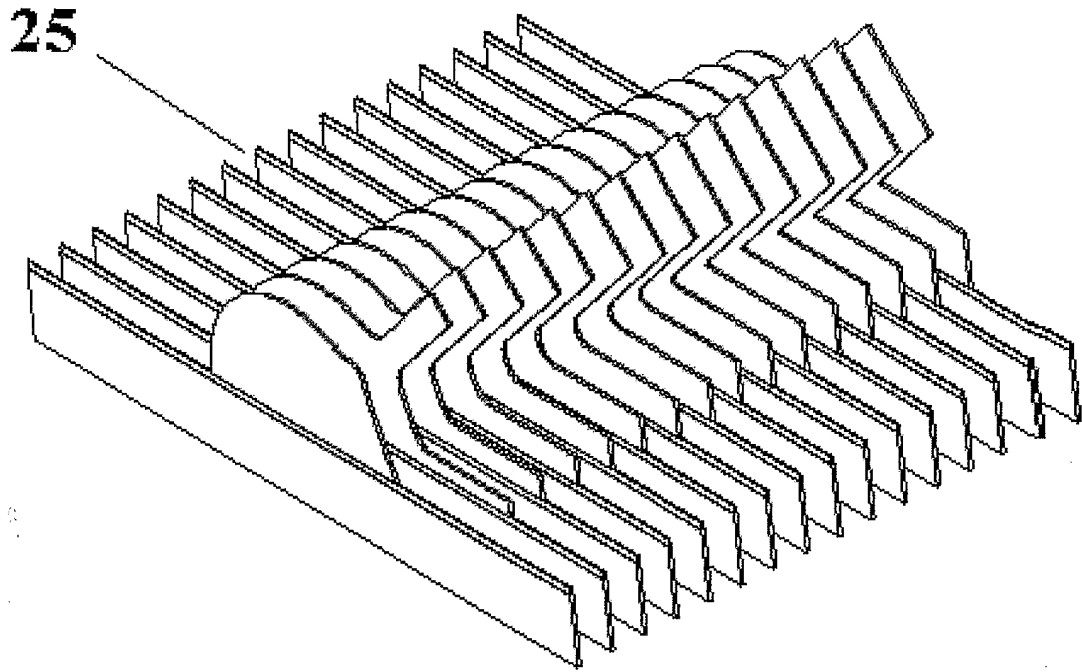

FIG. 10

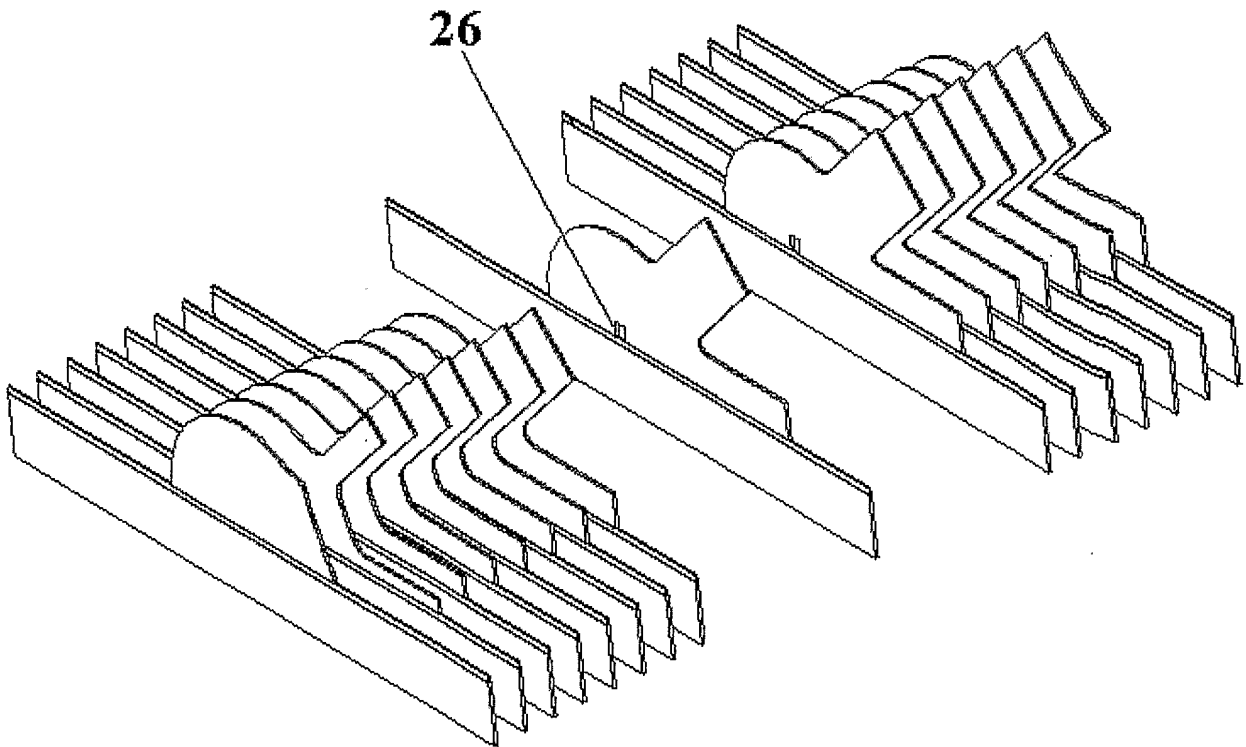

FIG. 11

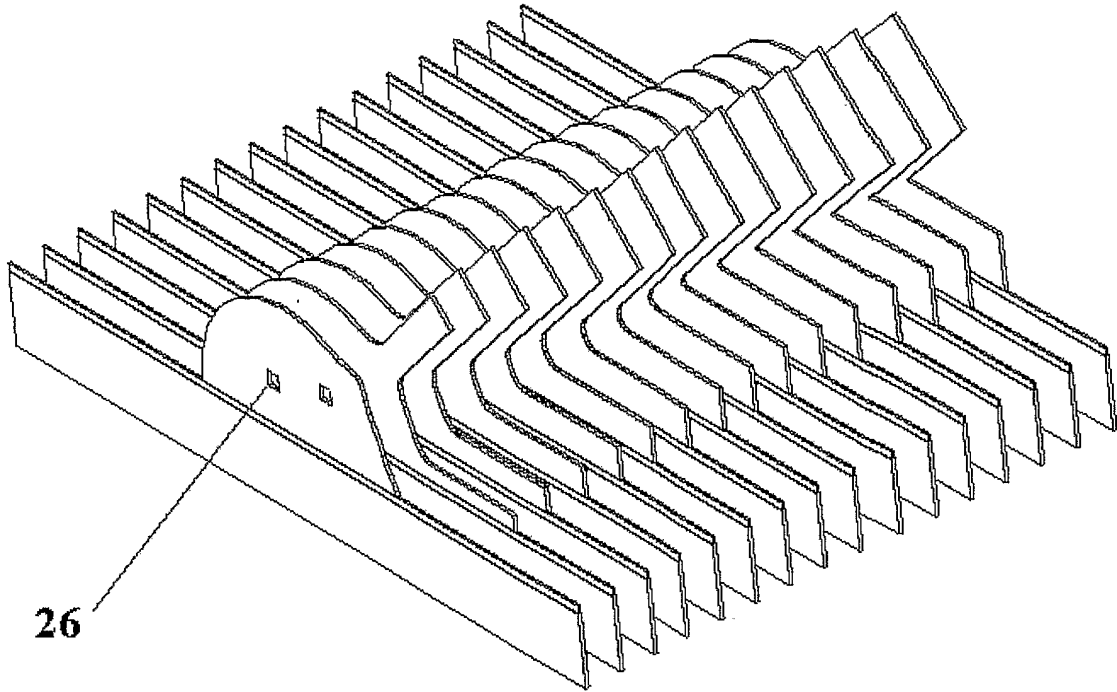

FIG. 12

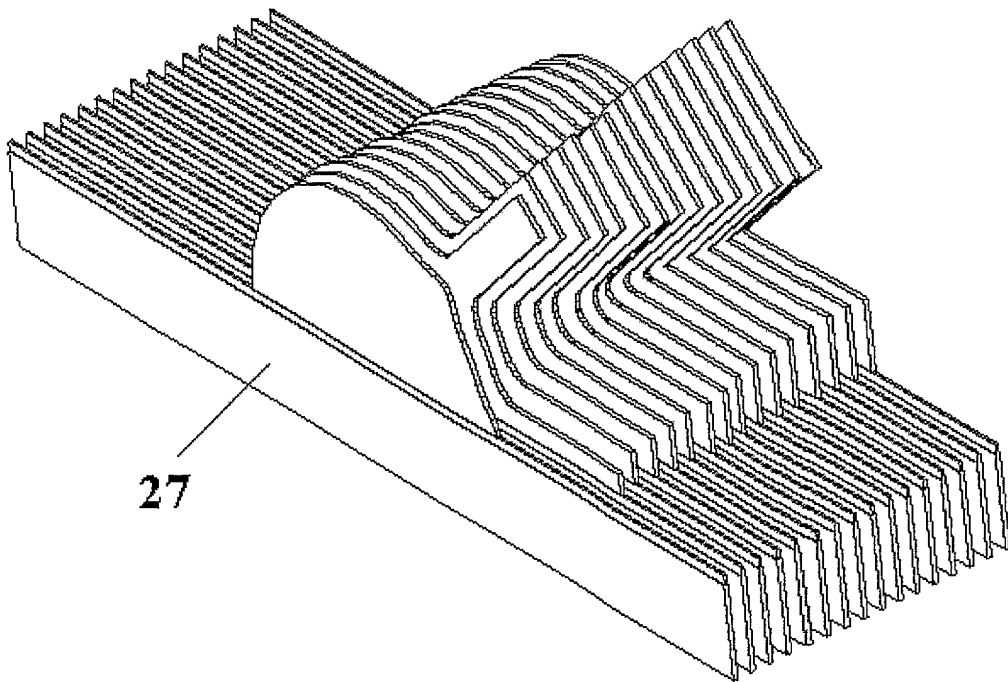

FIG. 13

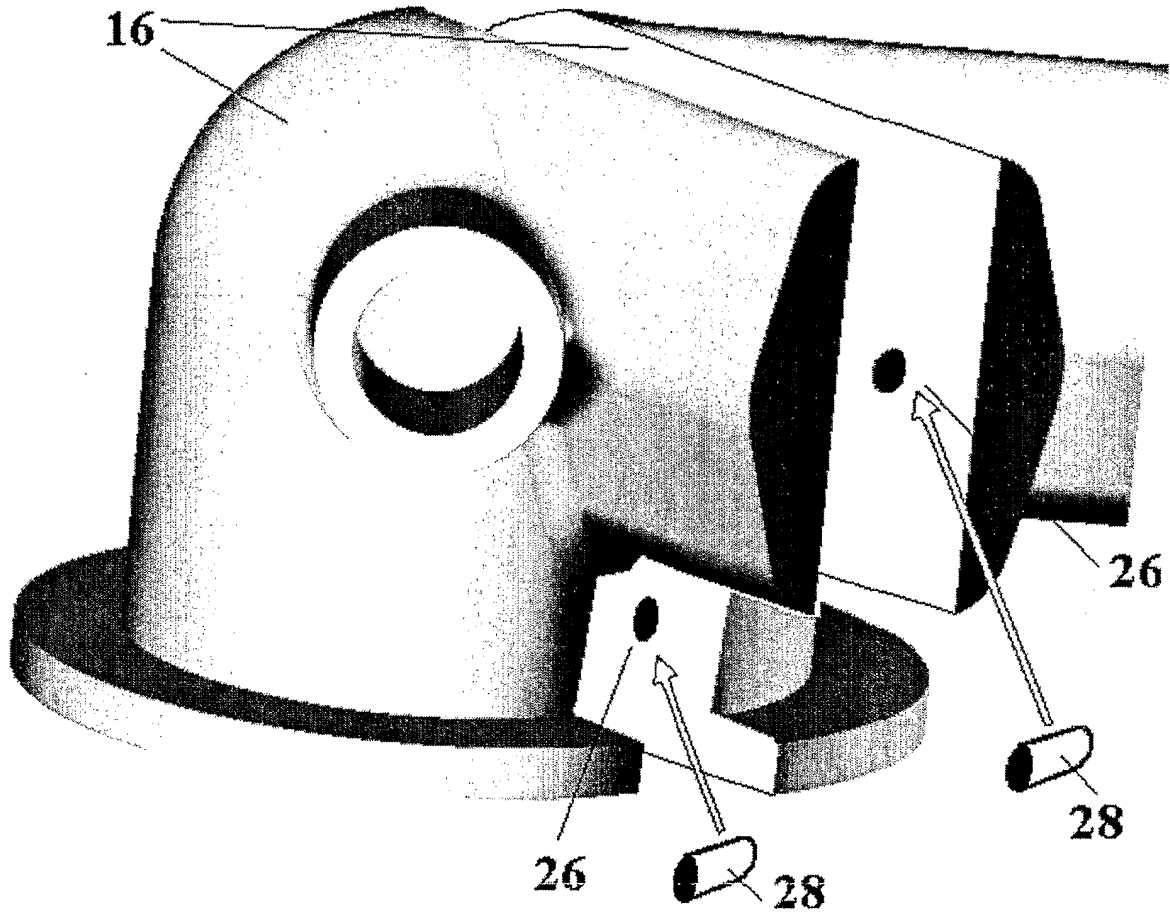

FIG. 14

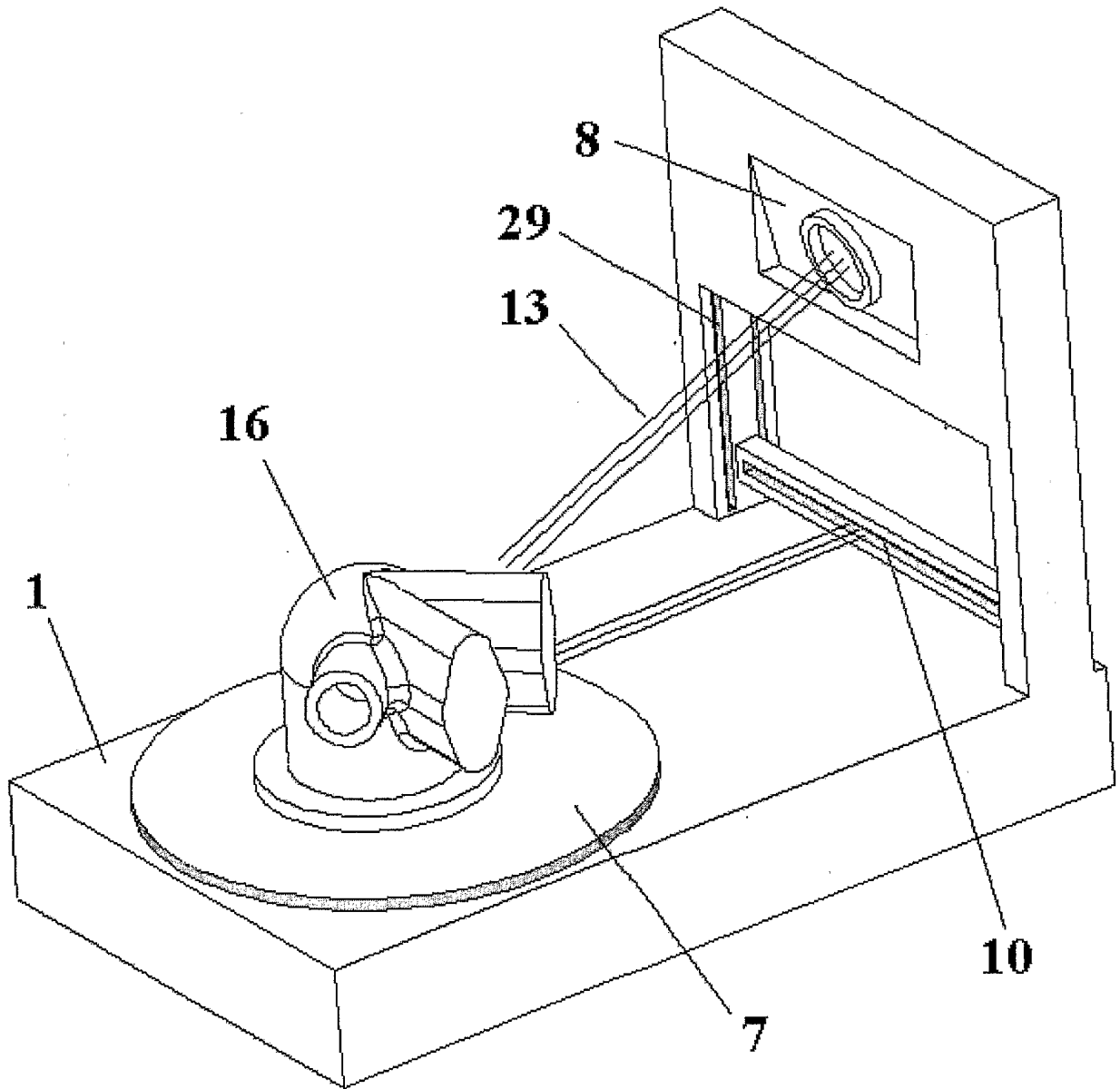

FIG. 15

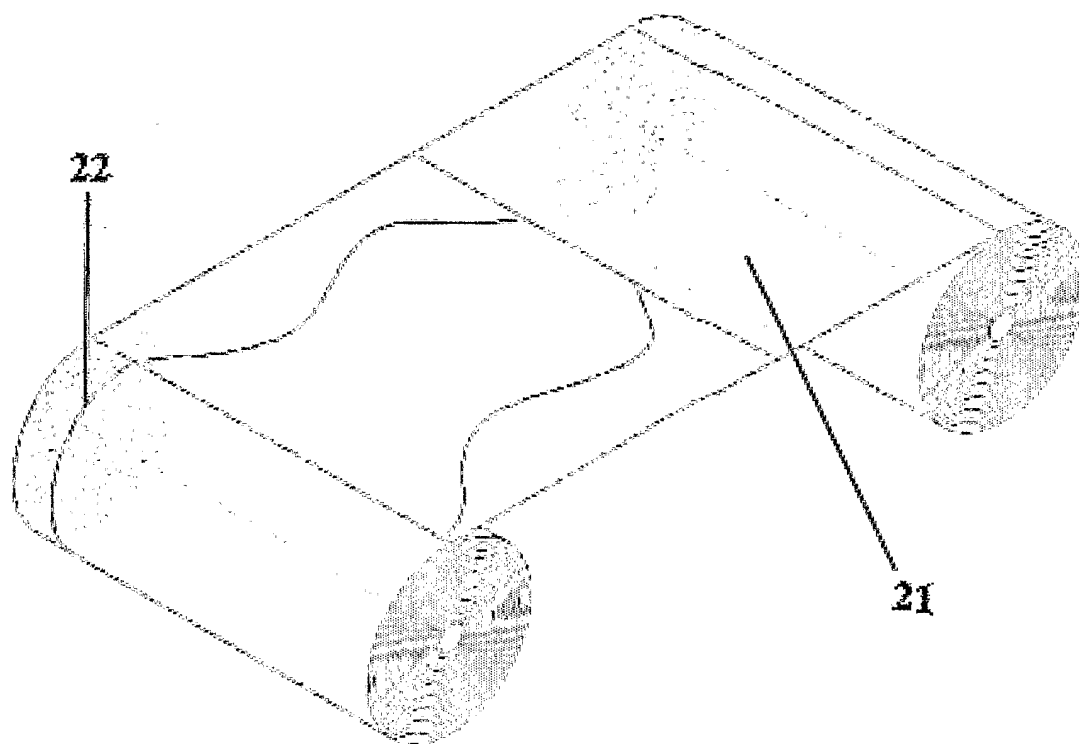

FIG.16

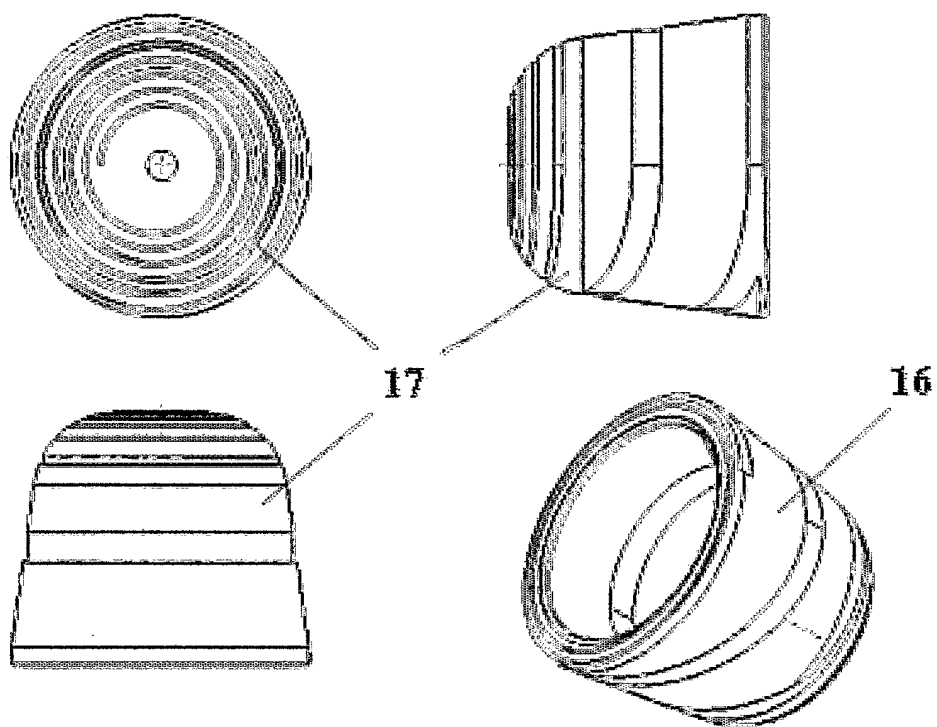

FIG.17