



**Europäisches Patentamt**  
**European Patent Office**  
**Office européen des brevets**

⑪ Publication number:

**0 201 968**  
**B1**

⑫

## EUROPEAN PATENT SPECIFICATION

④⑤ Date of publication of the patent specification:  
**09.08.89**

⑤① Int. Cl.4: **B65D 1/38**

②① Application number: **86200775.4**

②② Date of filing: **02.05.86**

⑤④ **Crate.**

③⑩ Priority: **14.05.85 NL 8501395**

⑦③ Proprietor: **WAVIN B.V., Händellaan 251, NL-8031 EM Zwolle(NL)**

④③ Date of publication of application:  
**20.11.86 Bulletin 86/47**

⑦② Inventor: **Benraad, Coenraad Johannes Bartholomeus M., 19, Rheezerend, NL-7701 BC Dedemsvaart(NL)**

④⑤ Publication of the grant of the patent:  
**09.08.89 Bulletin 89/32**

⑦④ Representative: **van der Veken, Johannes Adriaan et al, EXTERPATENT B.V. P.O. Box 90649, NL-2509 LP 's-Gravenhage(NL)**

⑧④ Designated Contracting States:  
**AT BE CH DE FR GB IT LI LU NL SE**

⑤⑥ References cited:  
**DE-A- 2 740 871**  
**DE-A- 2 915 981**  
**FR-A- 2 105 228**

**EP 0 201 968 B1**

Note: Within nine months from the publication of the mention of the grant of the European patent, any person may give notice to the European Patent Office of opposition to the European patent granted. Notice of opposition shall be filed in a written reasoned statement. It shall not be deemed to have been filed until the opposition fee has been paid (Art. 99(1) European patent convention).

## Description

The invention relates to a crate having a substantially rectangular outer periphery and provided with a partitioning for arranging bottles or like objects in three rows, the bottles in one row being staggered in relation to those in another row.

A crate of this kind is known from French Patent No. 1,362,176.

In view of the fact that for the transport of crates use is generally made of pallets of standardized dimensions, it will be endeavoured to select the outside dimensions of the crates in such a manner that when the crates are placed on a pallet on the one hand the loading surface of the pallet will be completely utilized, while on the other hand the crates will not project beyond the edges of the pallet. In some cases it is not possible for three rows of bottles or like objects to be placed one next to the other in a crate when the latter has outside dimensions adapted to the standardized dimensions of the pallet, although the space is quite sufficient for a determined number of bottles in a row. As a solution to this problem a partitioning may be provided in the crate, with the bottles in the middle row staggered in relation to the bottles in the two outer rows, in the manner as for the known crate of French Patent Specification No. 1,362,176. The distance between the axes of two adjoining rows can then be shorter than in the cases of rows of bottles which are not mutually staggered. In the crate according to the above-mentioned French Patent Specification the distance by which bottles in the middle row are staggered in relation to the bottles in the two outer rows is equal to half the distance between centres of the bottles in a row. This distance may however also be shorter than the distance between centres of the bottles in a row, and is dependent, among other factors, on the outside dimensions of the crate, the diameter of the bottles, and the desired number of bottles in a row.

The drawback of such a partitioning is that the position of the compartments, viewed from one side wall extending transverse to the rows, of the crate is different from that viewed from the opposite wall extending transverse to the rows. This gives rise to problems in the automatic filling and emptying of crates. Additional facilities must then be provided in the machines in order to position the crates and the filling or extractor apparatus in relation to one another.

The object of the invention is now to provide a crate of the type described above, which is provided with a partitioning which does not show the drawback mentioned above.

This object is achieved with a crate which is characterized in that the partitioning is skewsymmetric in relation to the axes extending through the centre point of the crate and parallel to the side walls of the crate, while the bottles in the two outer rows are staggered relative to each other.

It is thereby ensured that in a crate of the type first defined above the position of the compartments, viewed from one side wall, extending trans-

verse to the rows, of the crate is the same as that viewed from the opposite side wall extending transverse to the rows. In other words, when the crate is turned 180° the position of the compartments is once again the same as in the starting position, so that in the automatic filling or emptying of the crates no additional action has to be taken to turn certain crates through an angle of 180° relative to the filling or emptying machine.

One outer row of bottles preferably lies, in a corner of the crate, against one side wall of the crate, extending transverse to the rows, and the other outer row of bottles, in the corner obliquely opposite said corner of the crate, against the opposite side wall of the crate, extending transverse to the rows, whereby optimum arrangement of the bottles is achieved.

In one advantageous embodiment of the crate according to the invention the middle row of bottles is a continuous row which, viewed in the lengthwise direction of the rows, is situated in the middle between the two outer rows, which are staggered in relation to one another. The bottles at the two ends of the middle row thus lie clear of the side walls of the crate which extend transverse to the rows of bottles, so that, if hand openings are provided in these side walls, it is easy to insert the hands into these openings.

In another embodiment of the crate according to the invention the middle row of bottles is divided into two halves, which lie against the oppositely situated crate side walls extending transverse to the rows. In the middle region of the crate a space is thus provided between the compartments, wherein a central handle can optionally be disposed.

The invention will now be explained with the aid of one example of embodiment and of the drawings, in which:

Figure 1 is a diagrammatical top plan view of one embodiment of the crate according to the invention, and

Figure 2 is a diagrammatical top plan view of another embodiment of the crate according to the invention.

The embodiments of the crate according to the invention which are shown in Figures 1 and 2 are intended to hold twelve bottles 1, arranged in three rows of four bottles each. Both embodiments of the crate have a substantially rectangular outer periphery. In general, the outside dimensions of the crate will be adapted to the standardized dimensions of a pallet, so that a determined number of crates will exactly completely fill the loading surface of the pallet.

The bottles which are to be placed in the crate have an outside diameter such that it is not possible to arrange three bottles side by side in the direction of the width of the crate. In order nevertheless to be able to place the required number of twelve bottles in the crate with this combination of outside dimensions of the crate and bottle diameter, and also in order to enable the filling and emptying of the crate to be automated without providing additional facilities for positioning the crate in relation to the filling and emptying machines, the crate according to the invention is provided internally with a parti-

tioning 2 which is skewsymmetric with respect to the axes 7 and 8 respectively extending through the centre point and parallel to the respective side walls 3, 4 and 5, 6 of the crate, and which in addition is such that the bottles in the two outer rows are staggered relative to each other. One outer row of bottles lies, in the corner where the side walls 3 and 6 adjoin, against the side wall 6. In the opposite corner, where the side walls 4 and 5 adjoin, the other row of bottles lies against the side wall 5. In the embodiment shown in Figure 1 the partitioning is such that the middle row of bottles is a continuous row which, viewed in the lengthwise direction of the crate, is situated in the middle between the two outer rows of bottles which are staggered in relation to one another.

Gaps 9 and 10 are thus formed between the bottles situated at the two ends of this row and the short side walls 5, 6 of the crate. If hand openings are provided in the two short side walls 5, 6, approximately in the middle, these gaps 9, 10 will enable the crate to be picked up easily.

In the embodiment shown in Figure 2 the partitioning is such that the middle row of bottles is divided into two halves, and these two halves lie against the oppositely situated side walls 5 and 6. The two halves of the middle row of bottles come to lie, in a direction transverse to the rows, slightly offset with respect to one another. With this partitioning a space 11 is formed in the middle part of the crate, and can be used for the disposal of a central handle.

### Claims

1. Crate having a substantially rectangular outer periphery and provided with a partitioning (2) for arranging bottles (1) or like objects in three rows, the bottles (1) in one row being staggered in relation to those in another row, characterized in that the partitioning (2) is skewsymmetric in relation to the axes (7, 8) extending through the centre point of the crate and parallel to the side walls (3, 4 and 5, 6 respectively) of the crate, while the bottles (1) in the two outer rows are staggered relative to each other.

2. Crate according to Claim 1, characterized in that one outer row of bottles lies, in one corner of the crate, against the side wall (6), extending transverse to the rows, of the crate, and the other outer row of bottles lies, in the corner of the crate lying obliquely opposite said corner, against the opposite side wall (5), extending transverse to the rows, of the crate.

3. Crate according to Claim 1 or 2, characterized in that the middle row of bottles is a continuous row which, viewed in the lengthwise direction of the rows, is situated in the middle between the two outer rows of bottles which are staggered in relation to one another.

4. Crate according to Claim 1 or 2, characterized in that the middle row of bottles is divided into two halves which lie against the oppositely situated side walls (5, 6), extending transverse to the rows, of the crate.

5. Crate according to Claim 4, characterized in that the two halves of the middle row of bottles are

offset relative to one another in the direction transverse to the rows.

6. Crate according to Claim 4 or 5, characterized in that a central handle is disposed in the middle part of the crate, at the site of a space (11) between the two halves of the middle row of bottles.

### Patentansprüche

1. Kasten mit einem im wesentlichen rechteckigen Außenumfang und mit einer Unterteilung (2) zum Anordnen von Flaschen (1) oder dgl. Gegenständen in drei Reihen, wobei die Flaschen (1) in einer Reihe in bezug auf diejenigen in einer anderen Reihe versetzt sind, dadurch gekennzeichnet, daß die Unterteilung (2) schiefssymmetrisch in bezug auf die Achsen (7, 8) ist, die sich durch den Mittelpunkt des Kastens und parallel zu den Seitenwänden (3, 4 bzw. 5, 6) des Kastens erstrecken, wobei die Flaschen (1) in den beiden Außenreihen zueinander versetzt sind.

2. Kasten nach Anspruch 1, dadurch gekennzeichnet, daß eine äußere Flaschenreihe in einer Ecke des Kastens an der quer zu den Reihen verlaufenden Seitenwand (6) des Kastens anliegt und die andere äußere Flaschenreihe in der der genannten Ecke schräg gegenüberliegenden Ecke des Kastens an der quer zu den Reihen verlaufenden gegenüberliegenden Seitenwand (5) des Kastens anliegt.

3. Kasten nach Anspruch 1 oder 2, dadurch gekennzeichnet, daß die mittlere Flaschenreihe eine kontinuierliche Reihe ist, die, in Längsrichtung der Reihen gesehen, in der Mitte zwischen den beiden äußeren Flaschenreihen, die zueinander versetzt sind, angeordnet ist.

4. Kasten nach Anspruch 1 oder 2, dadurch gekennzeichnet, daß die mittlere Flaschenreihe in zwei Hälften unterteilt ist, die an den einander gegenüberliegenden, quer zu den Reihen verlaufenden Seitenwänden (5, 6) des Kastens anliegen.

5. Kasten nach Anspruch 4, dadurch gekennzeichnet, daß die beiden Hälften der mittleren Flaschenreihe in Richtung quer zu den Reihen zueinander versetzt sind.

6. Kasten nach Anspruch 4 oder 5, dadurch gekennzeichnet, daß ein mittlerer Handgriff im mittleren Teil des Kastens an der Stelle eines Zwischenraums (11) zwischen den beiden Hälften der mittleren Flaschenreihe angeordnet ist.

### Revendications

1. Caisse à claire-voie présentant une périphérie extérieure sensiblement rectangulaire et comprenant un cloisonnement (2) permettant de disposer des bouteilles (1) ou des objets analogues selon trois rangées, les bouteilles (1) d'une rangée étant disposées en quinconce par rapport à celles d'une autre rangée, caractérisée en ce que le cloisonnement (2) est symétrique gauche par rapport aux axes (7, 8) traversant le point central de la caisse à claire-voie et parallèlement aux parois latérales (3, 4 et 5, 6 respectivement) de la caisse à claire-voie, tandis que les bouteilles (1) des deux rangées exté-

rieures sont disposées en quinconce les unes par rapport aux autres.

2. Caisse à claire-voie selon la revendication 1, caractérisée en ce qu'une rangée extérieure de bouteilles est située, dans un angle de la caisse à claire-voie, contre la paroi latérale (6), s'étendant transversalement par rapport aux rangées de la caisse à claire-voie, et l'autre rangée extérieure de bouteilles est située, dans l'angle de la caisse située obliquement à l'opposée dudit angle, contre la paroi latérale opposée (5) s'étendant transversalement par rapport aux rangées, de la caisse à claire-voie.

3. Caisse à claire-voie selon la revendication 1 ou 2, caractérisée en ce que la rangée médiane de bouteilles est une rangée continue qui, vue selon le sens de la longueur des rangées, est située au milieu entre les deux rangées extérieures de bouteilles qui sont disposées en quinconce l'une par rapport à l'autre.

4. Caisse à claire-voie selon la revendication 1 ou 2, caractérisée en ce que la rangée médiane de bouteilles est divisée en deux moitiés qui se trouvent contre les parois latérales opposées (5, 6) s'étendant transversalement par rapport aux rangées, de la caisse à claire-voie.

5. Caisse à claire-voie selon la revendication 4, caractérisée en ce que les deux moitiés de la rangée médiane de bouteilles sont décalées l'une par rapport à l'autre dans le sens transversal des rangées.

6. Caisse à claire-voie selon la revendication 4 ou 5, caractérisée en ce qu'une poignée centrale est disposée dans la partie médiane de la caisse, au niveau d'un espace (11) prévu entre les deux moitiés de la rangée médiane de bouteilles.

5

10

15

20

25

30

35

40

45

50

55

60

65

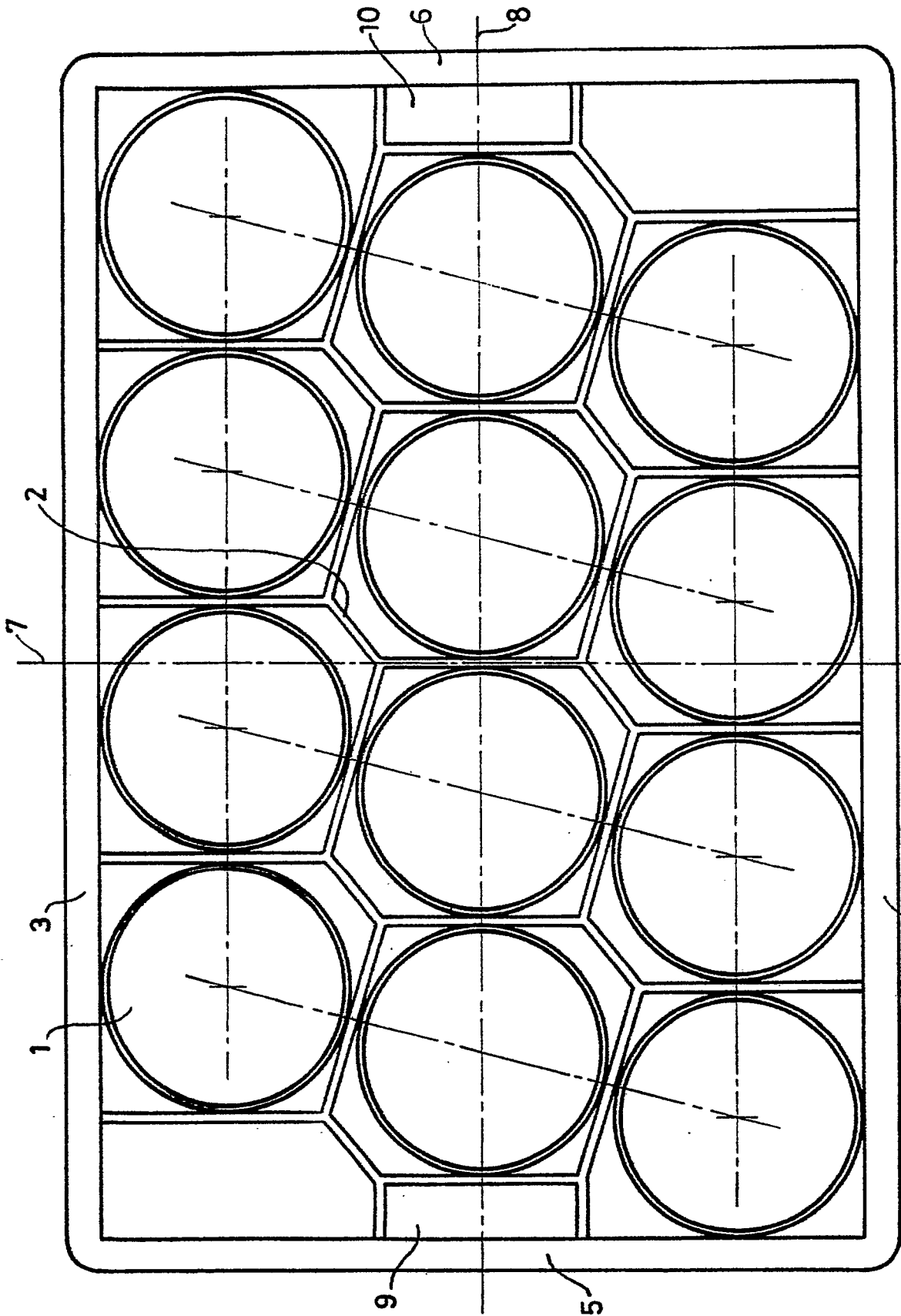

**FIG. 2.**

