



(19) **United States**

(12) **Patent Application Publication**  
**Irwin**

(10) **Pub. No.: US 2002/0183811 A1**

(43) **Pub. Date: Dec. 5, 2002**

(54) **TREATMENT OF SKIN DISORDERS WITH UV LIGHT AND COOLING**

(52) **U.S. Cl. .... 607/94**

(76) **Inventor: Dean S. Irwin, Del Mar, CA (US)**

Correspondence Address:  
**KNOBBE MARTENS OLSON & BEAR LLP**  
**2040 MAIN STREET**  
**FOURTEENTH FLOOR**  
**IRVINE, CA 91614 (US)**

(57) **ABSTRACT**

(21) **Appl. No.: 10/090,096**

(22) **Filed: Feb. 27, 2002**

**Related U.S. Application Data**

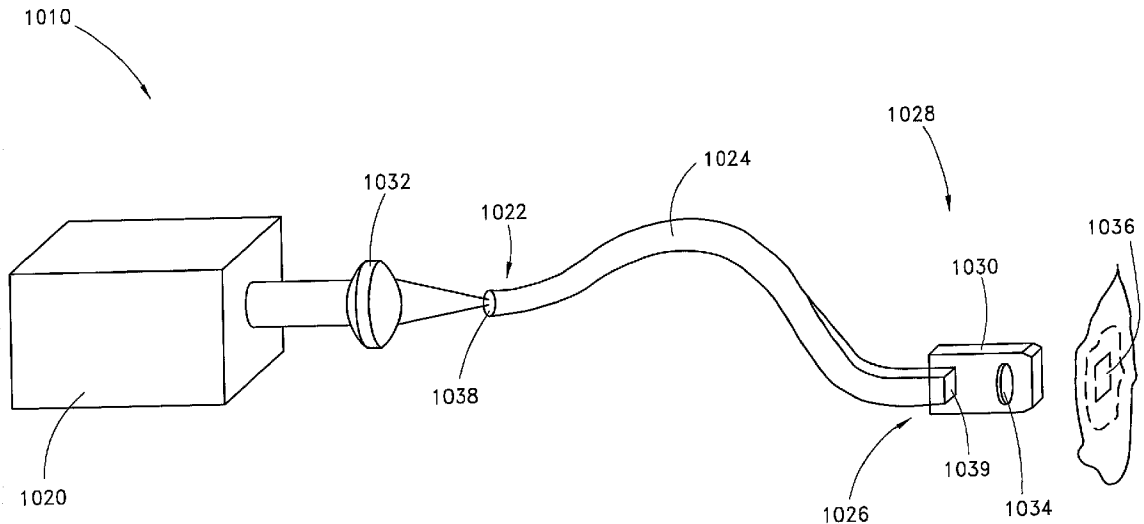
(63) Continuation-in-part of application No. 09/694,086, filed on Oct. 20, 2000.

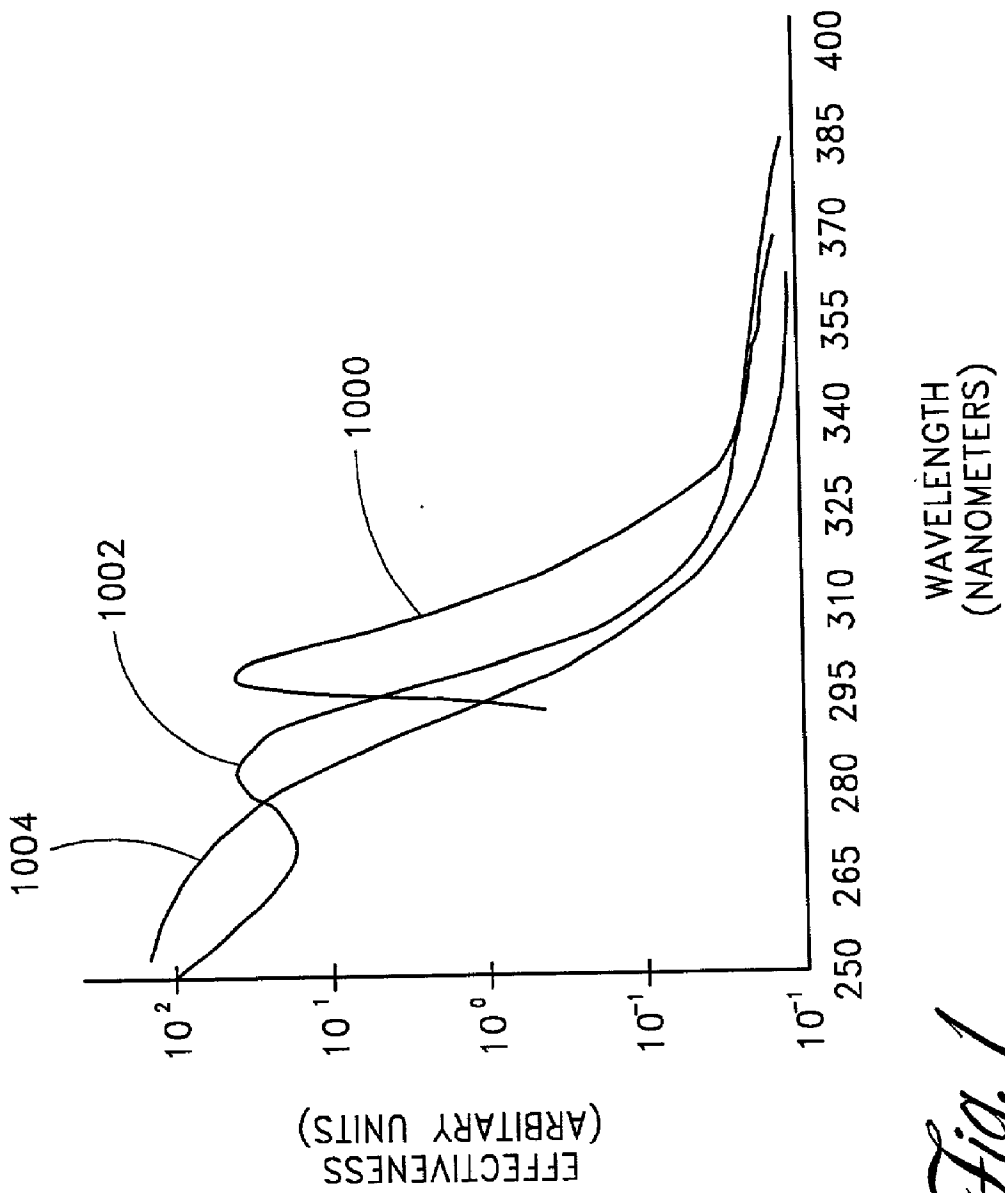
(60) Provisional application No. 60/272,277, filed on Feb. 28, 2001.

Skin disorders such as, for example, atopic dermatitis, dyshidrosis, eczema, lichen planus, psoriasis, and vitiligo, are treated by applying high doses of ultraviolet light to diseased regions of a patients skin. The dosage employed exceeds 1 MED, an MED being determined for the particular patient being treated, and may range from about 1 MED to about 20 MED or higher. The ultraviolet light has a wavelength within the range of between about 295 nanometers to about 320 nanometers and preferably is between about 300 nanometers and about 310 nanometers. High doses of ultraviolet light are restricted to diseased tissue areas so as to avoid risk of detrimental side affects in healthy skin, which is more susceptible to damage from UV light. Cooling the skin prior to and/or while exposing the skin to the UV light can be used to minimize tissue damage resulting from exposure to the UV light. Higher doses of UV light can therefore be employed without injurious affects.

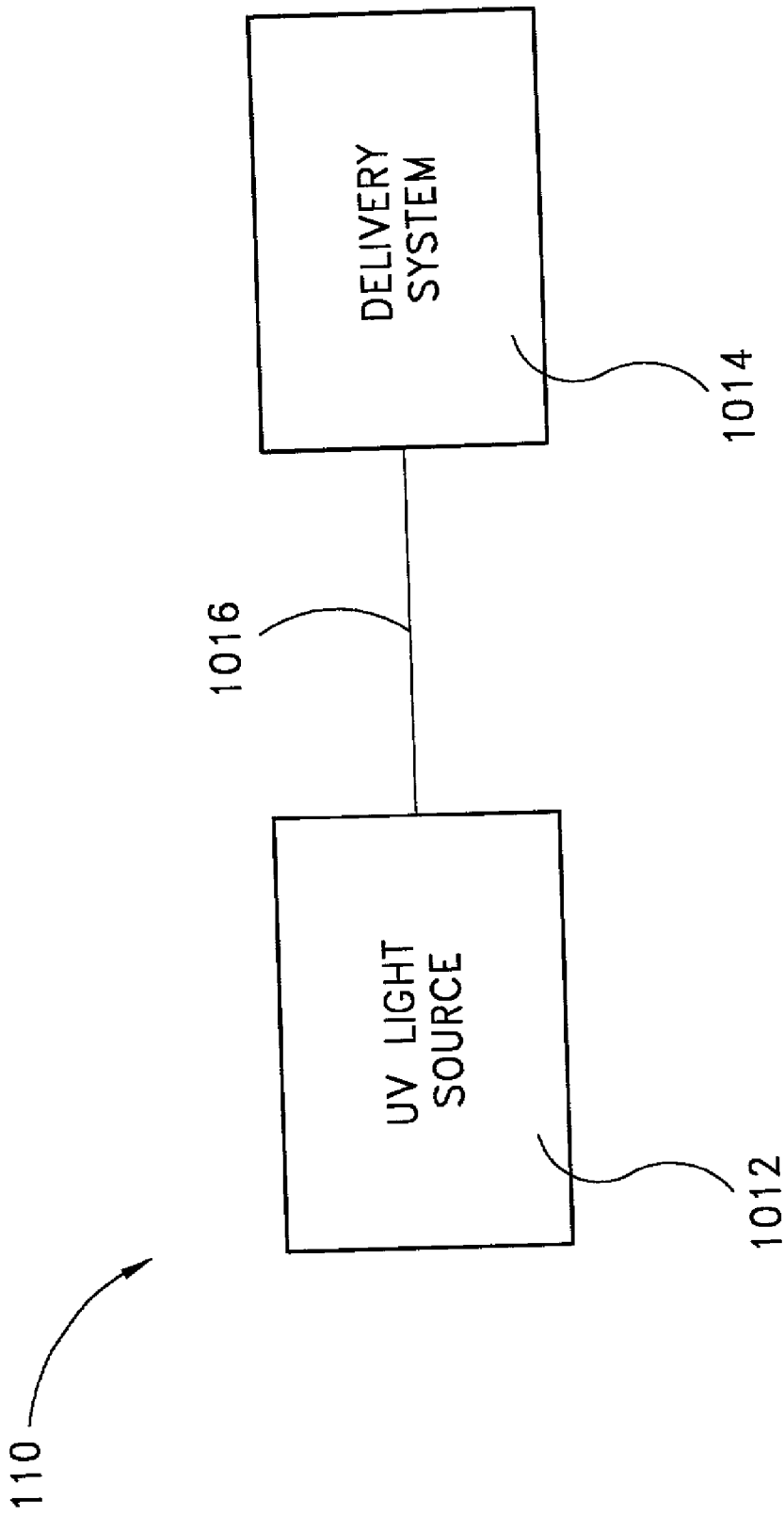
**Publication Classification**

(51) **Int. Cl.<sup>7</sup> ..... A61N 5/06**

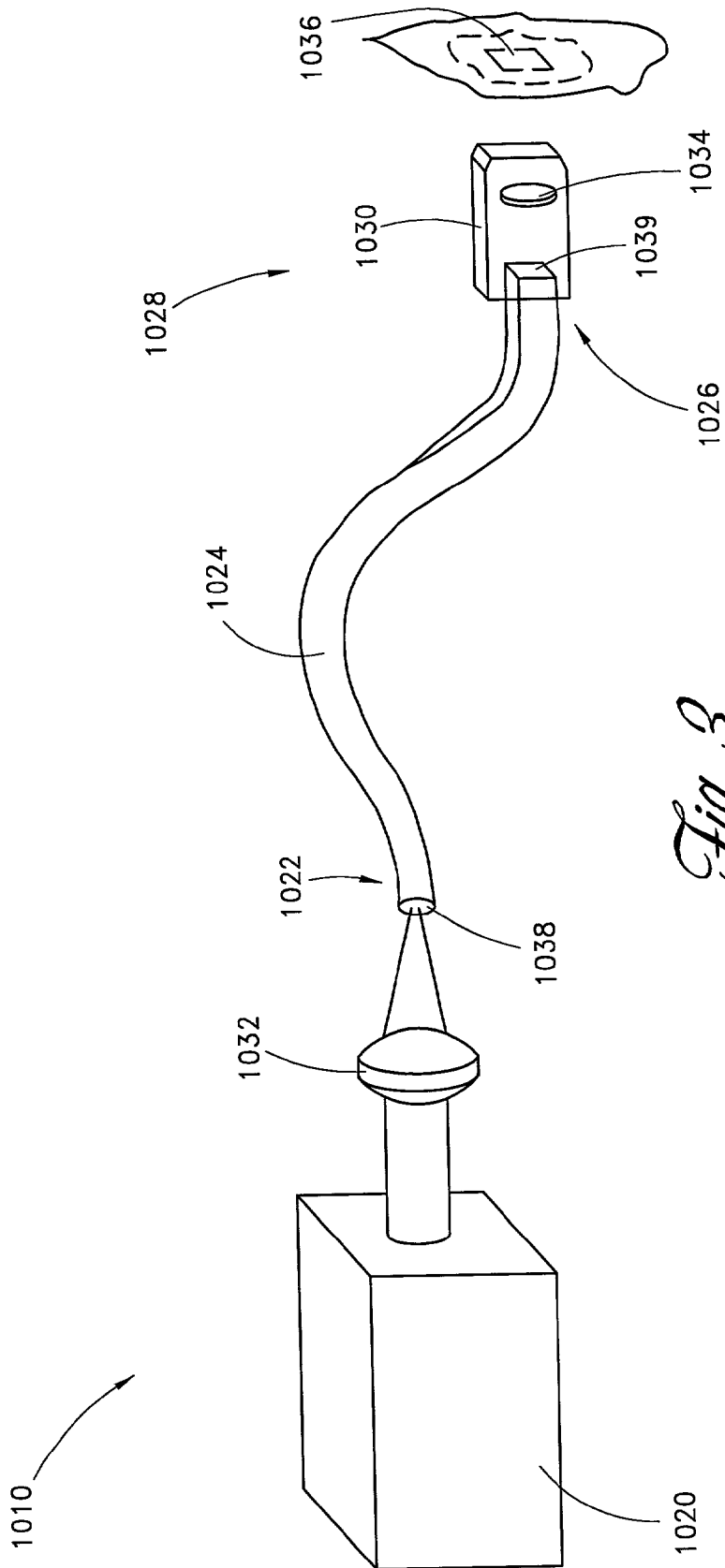




*Fig. 1*



*Fig. 2*



*Fig. 3*

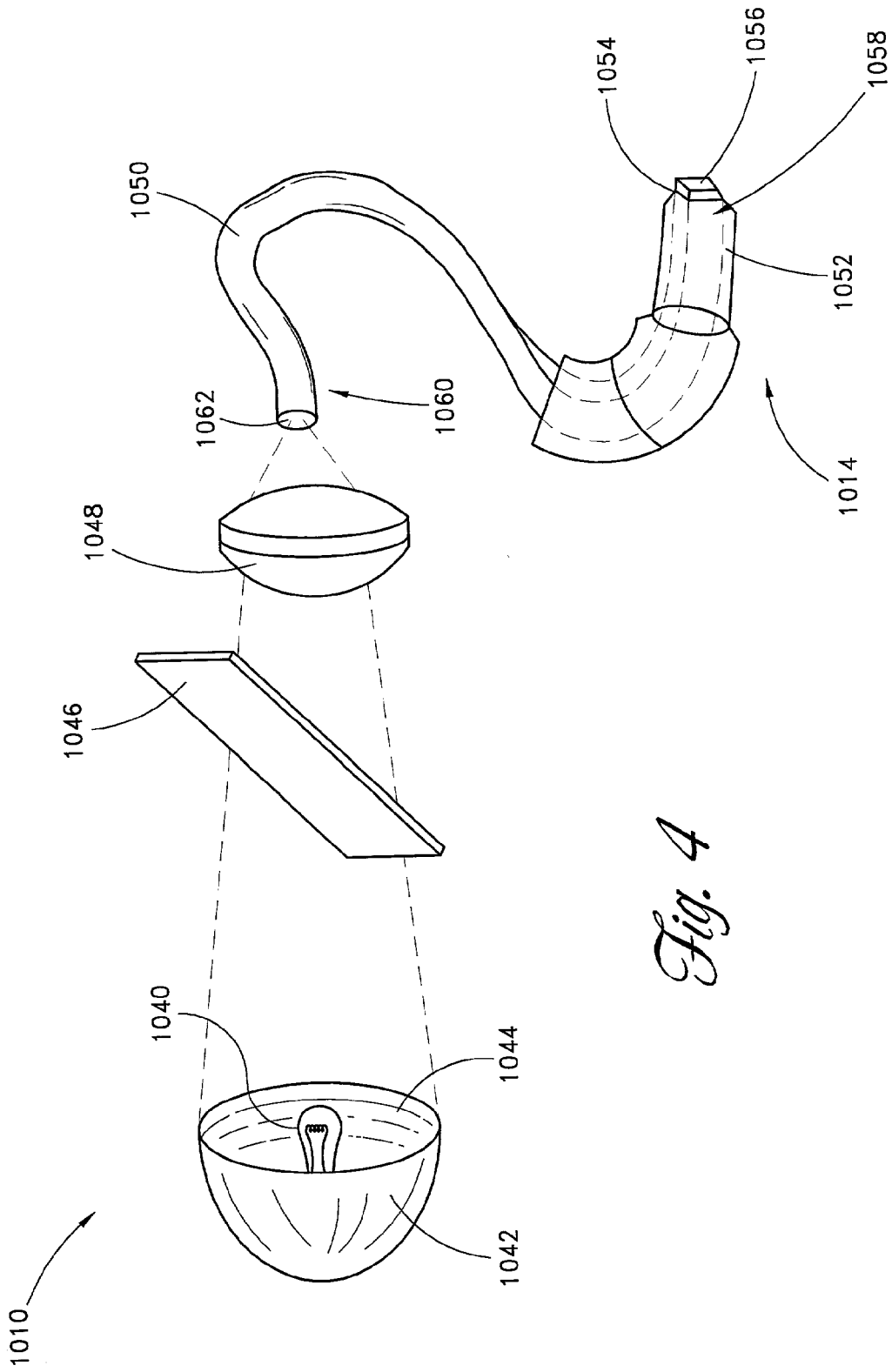
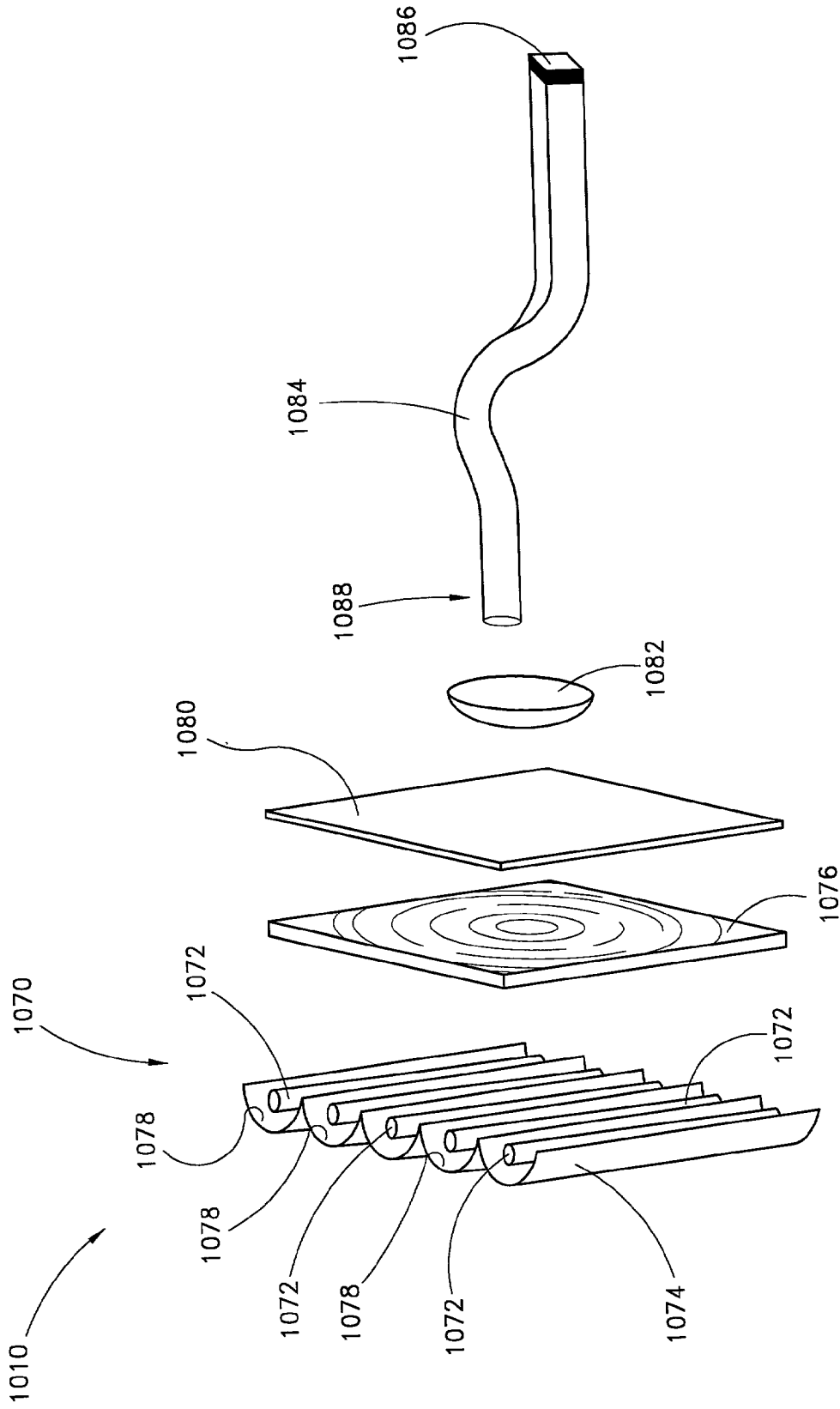
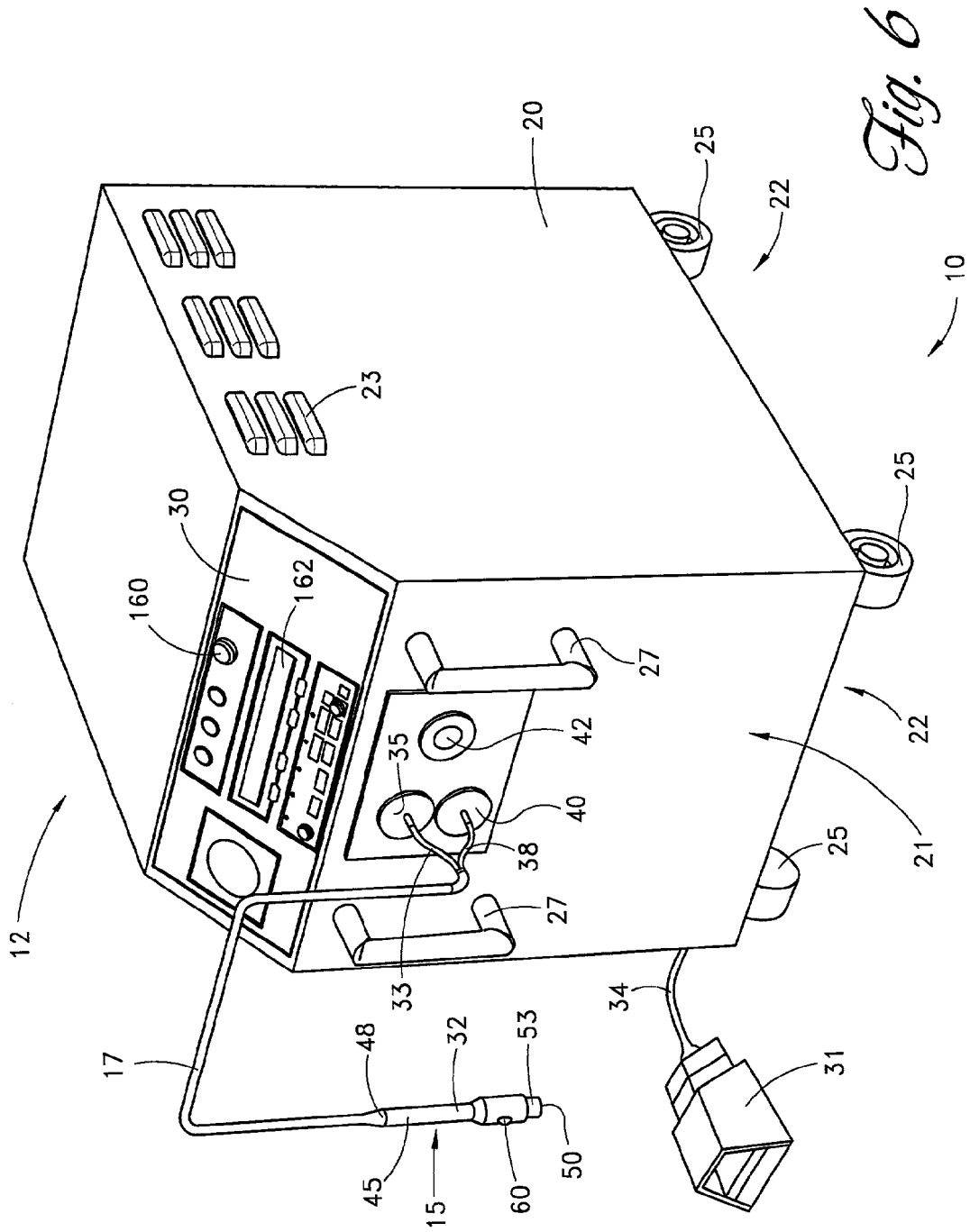
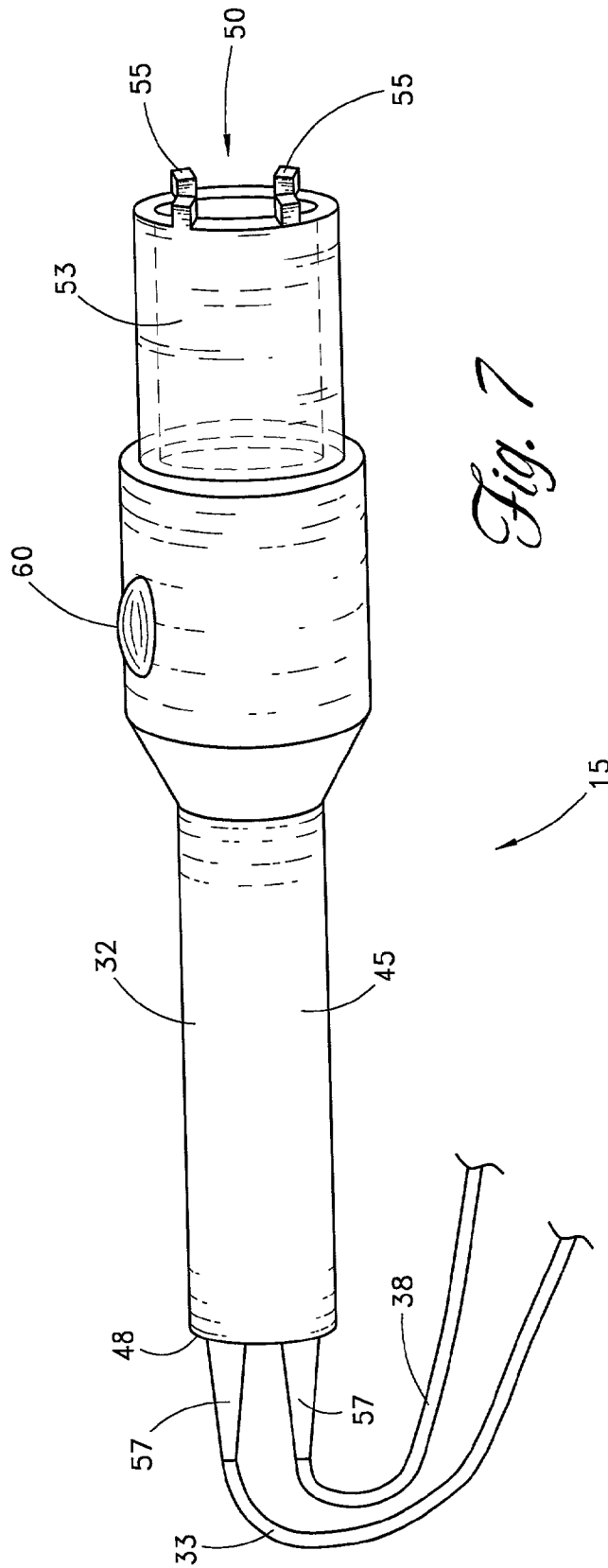


Fig. 4



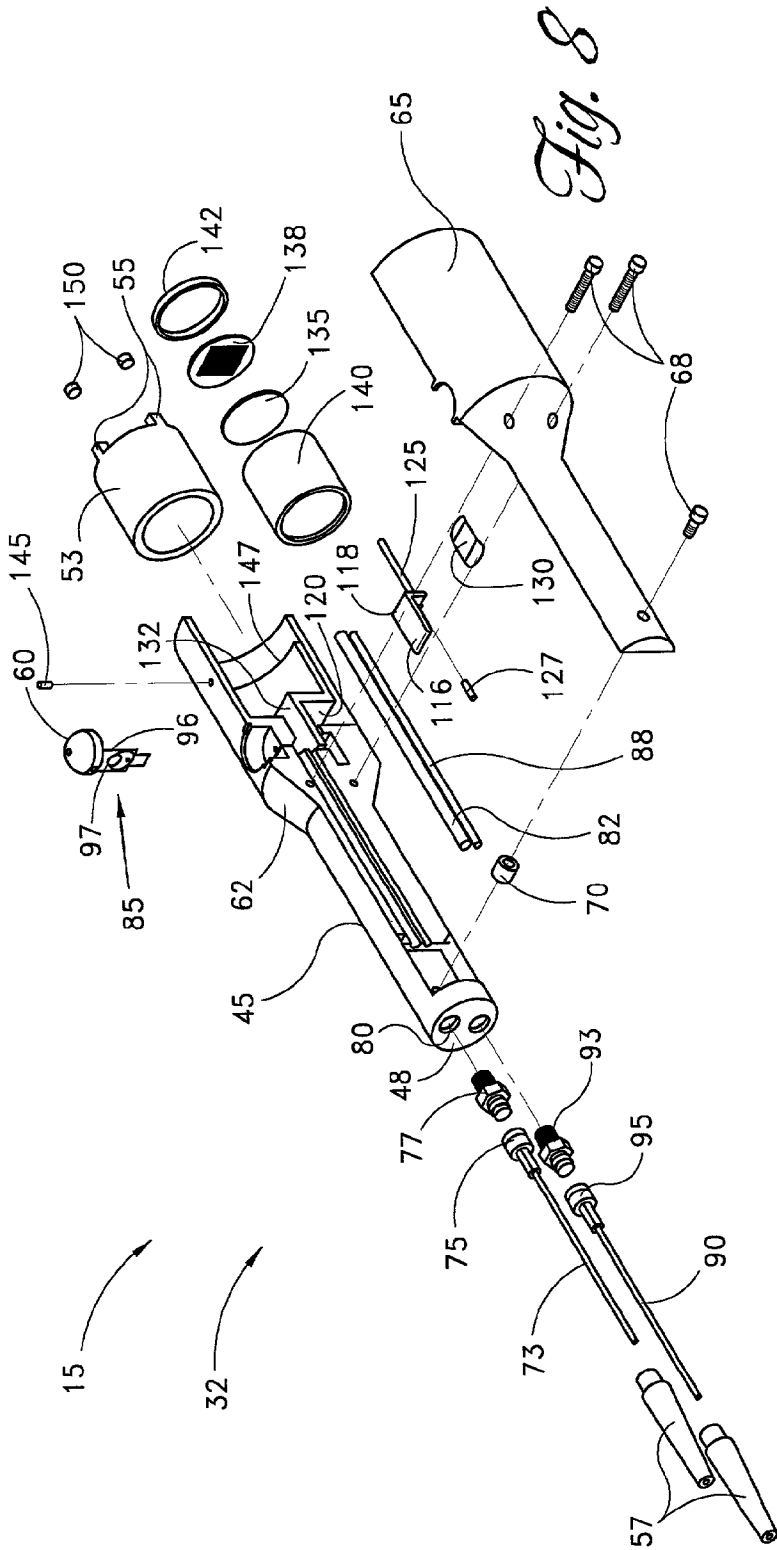
*Fig. 5*



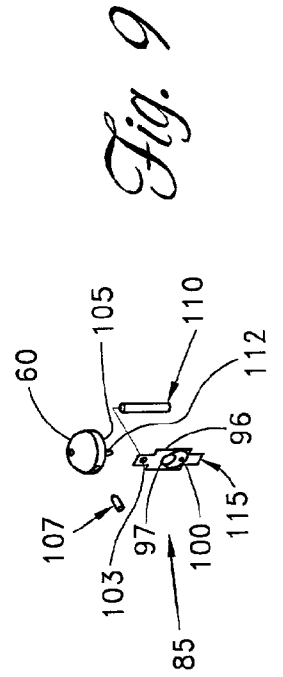


*Fig. 7*

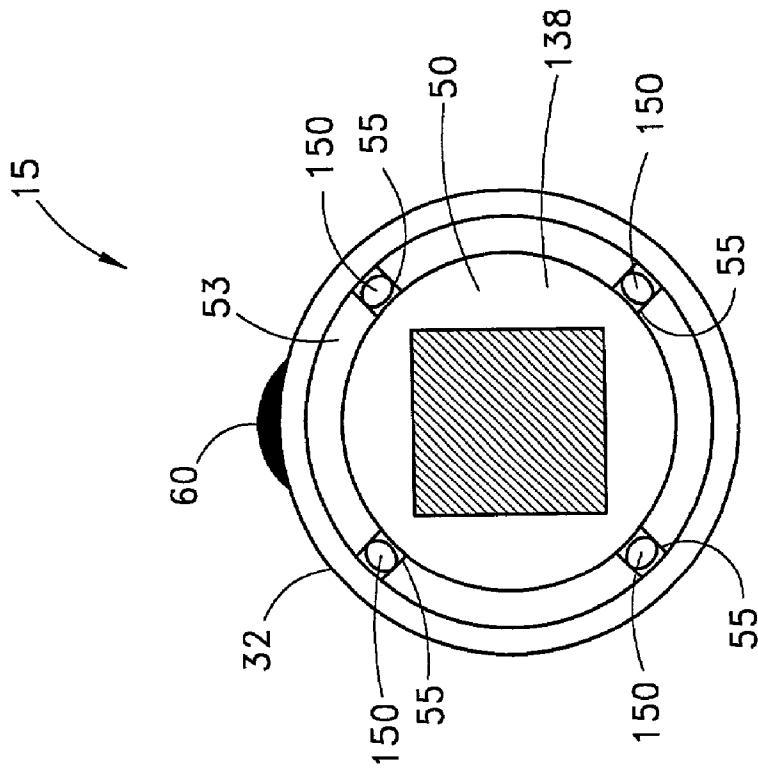




*Fig. 8*



*Fig. 9*



*Fig. 10*

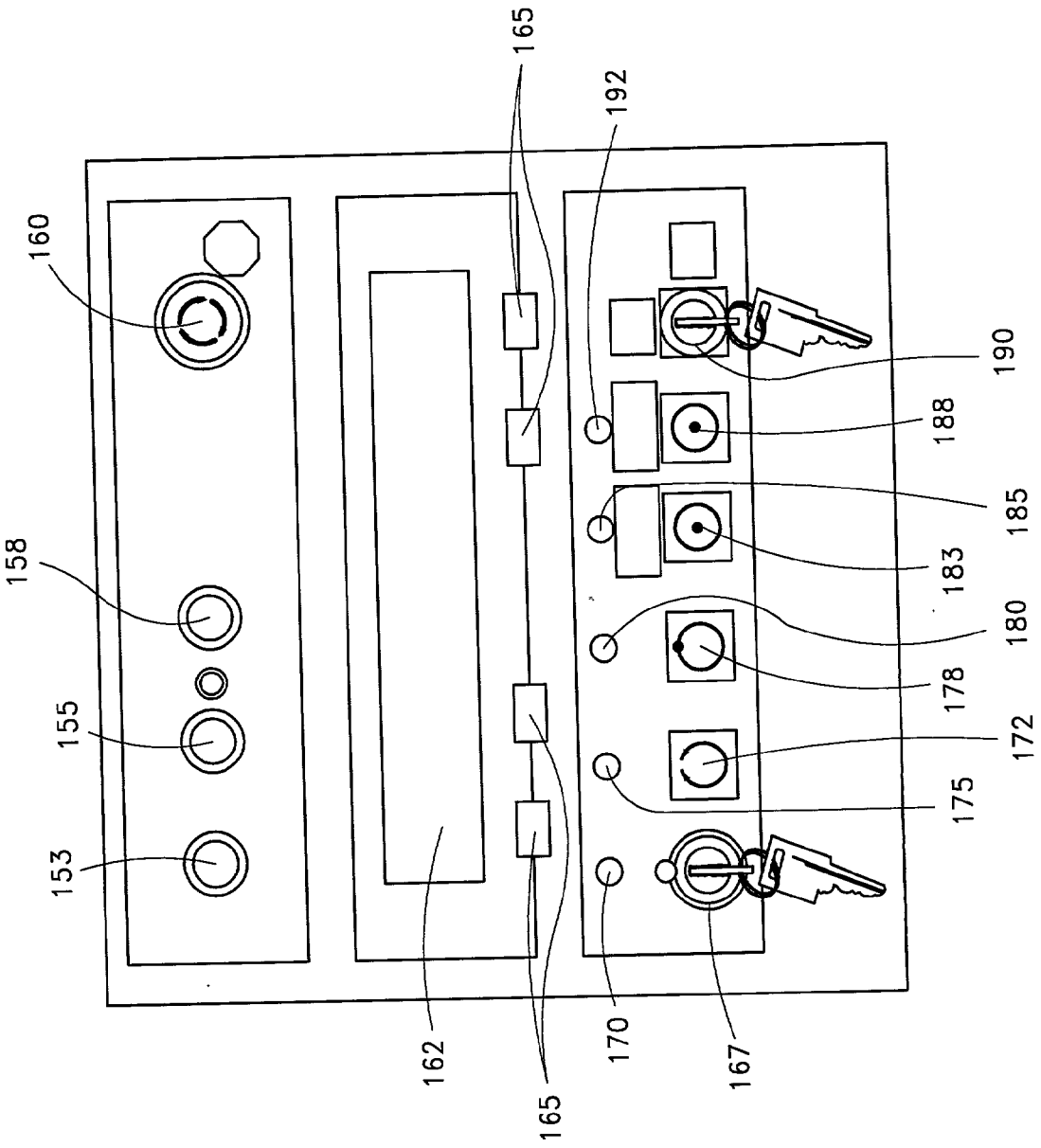
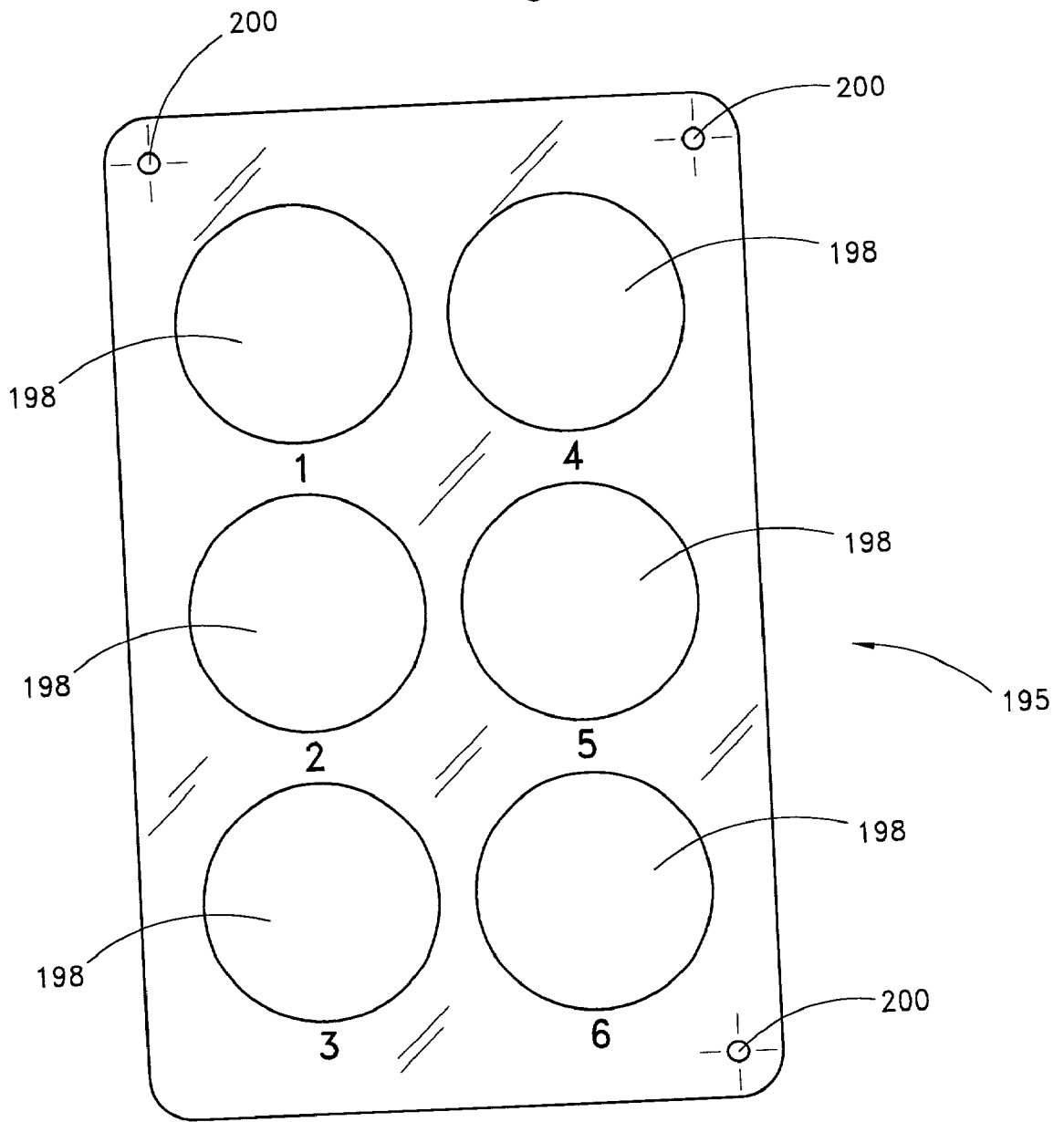
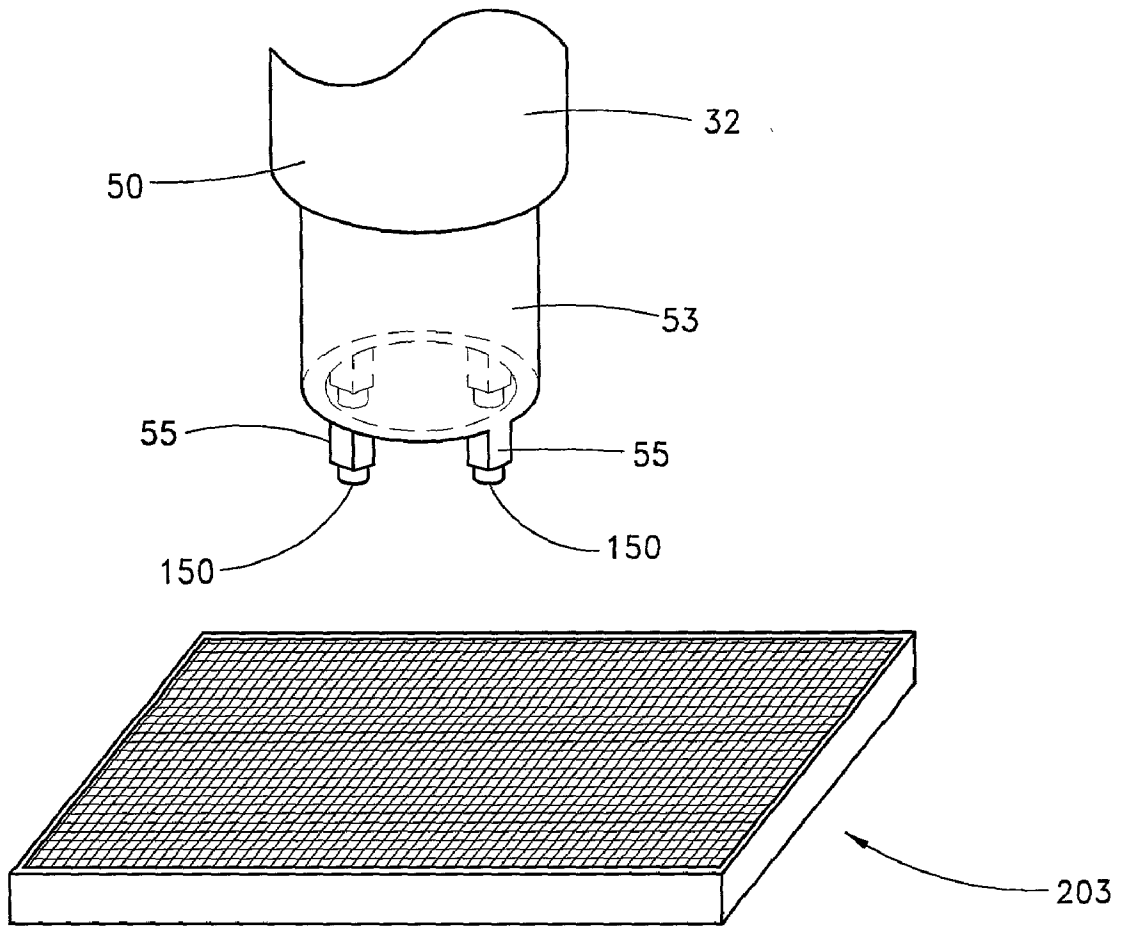


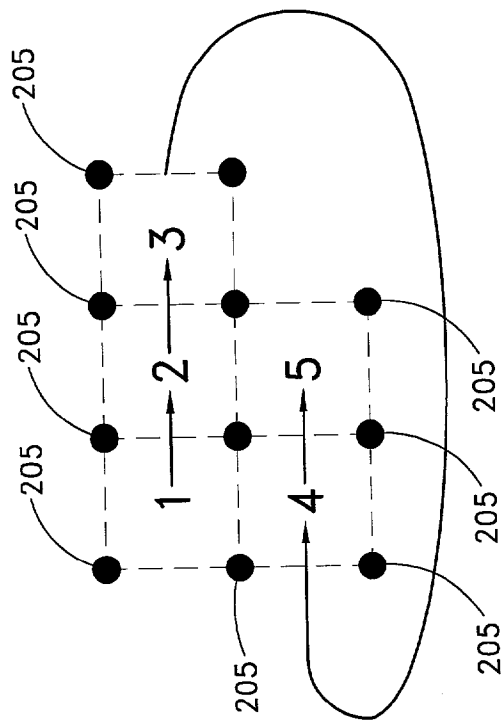
Fig. 11

*Fig. 12*

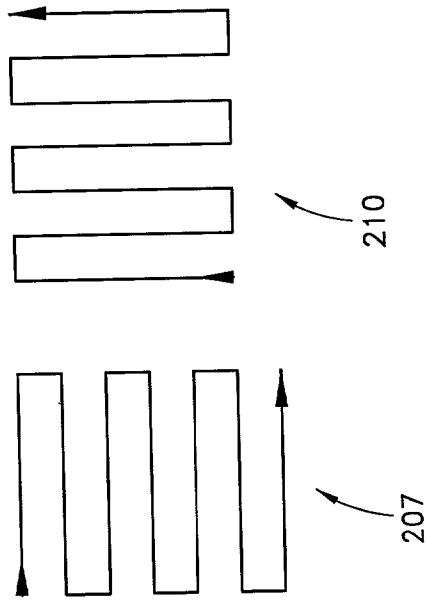




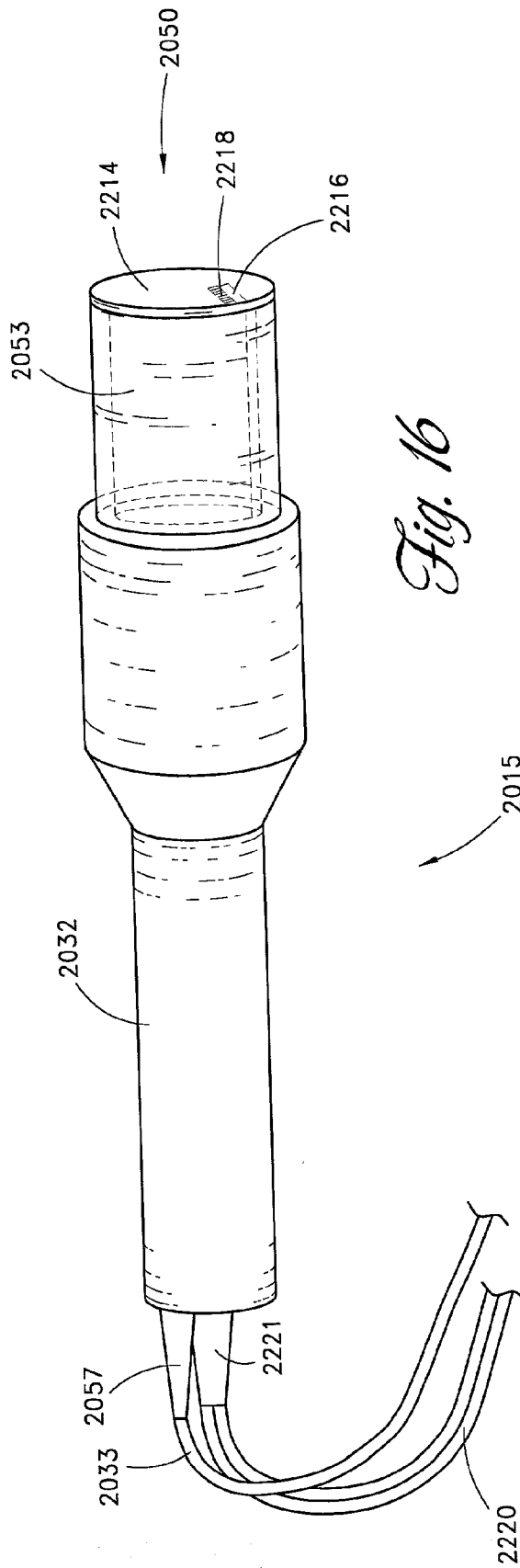
*Fig. 13*



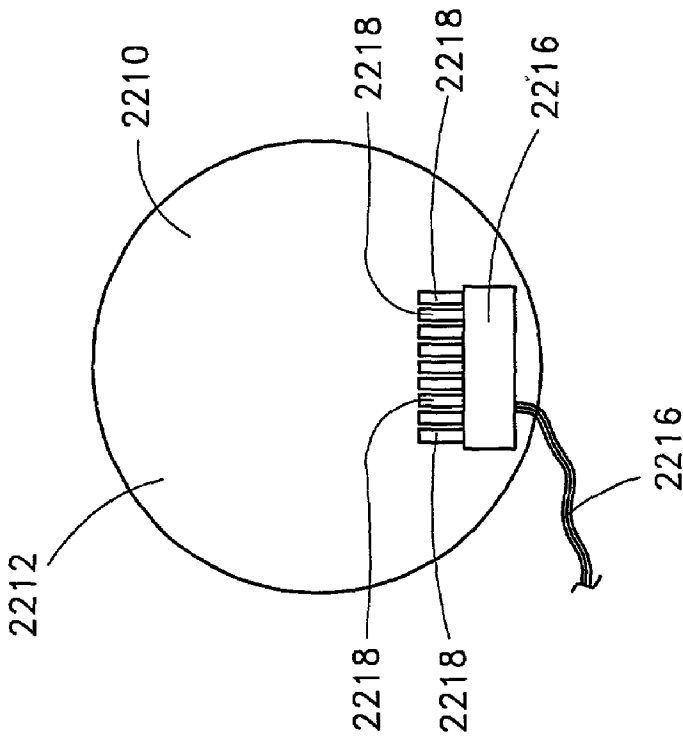
*Fig. 14*



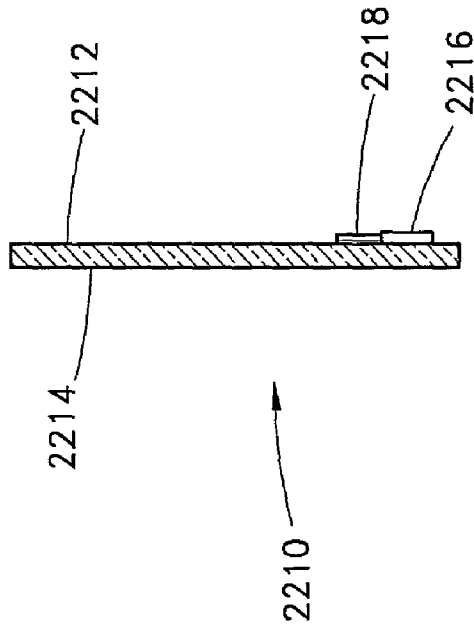
*Fig. 15*



*Fig. 16*

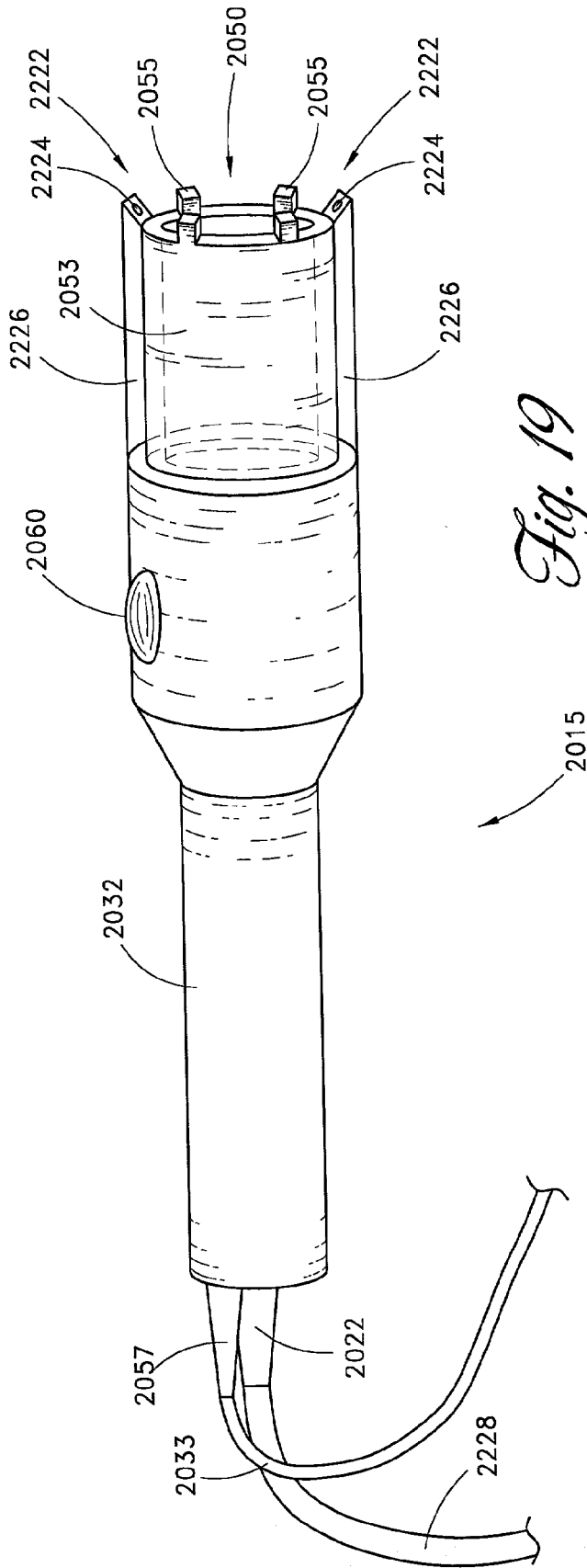


*Fig. 17*



*Fig. 18*





*Fig. 19*

## TREATMENT OF SKIN DISORDERS WITH UV LIGHT AND COOLING

### PRIORITY APPLICATION

[0001] This application is a Continuation-in-part of U.S. patent application No. 09/694,086, filed Oct. 20, 2000. This application also claims priority under 35 U.S.C. §119(e) from U.S. Provisional Patent Application No. 60/272,277, filed Feb. 28, 2001.

### BACKGROUND OF THE INVENTION

#### [0002] 1. Field of the Invention

[0003] The invention relates a method and apparatus for treating skin disorders such as psoriasis, and more specifically, to a method and apparatus for treating skin disorders involving exposing a patient's skin to high intensity ultraviolet (UV) light.

#### [0004] 2. Description of the Related Art

[0005] Skin disorders, including atopic dermatitis, dyshidrosis, eczema, lichen planus, psoriasis, and vitiligo, are conditions that commonly affect large populations at some time in their lives. For example, about 2% to 3% of the population of northern Europe is estimated to be afflicted with psoriasis. Although the disease's prevalence in the United States is not as well understood, it appears that between 150,000 and 260,000 new cases are diagnosed each year. This suggests that at least several million people suffer from the disease in the United States.

[0006] Psoriasis can range in severity from relatively mild, with some drying and flaking of the affected skin, to severe cases with very severe outbreaks over large areas of the patient's body. Even very mild psoriasis is uncomfortable and unsightly. Severe cases can be physically and psychologically debilitating, presenting a very serious threat to the patient's overall health.

[0007] Although the underlying mechanisms of psoriasis are not yet perfectly understood, the disease involves abnormally rapid cell proliferation in the basal layer of the skin. This hyperproliferation can be reduced and the disease ameliorated with what is conventionally known as "phototherapy," i.e., by exposing the affected skin surface to a source of light, in particular, ultraviolet light. Phototherapy can be performed simply by exposing the patient to natural sunlight, or in a more controlled way by applying light from an artificial source to the affected areas.

[0008] Commonly, a patient may be exposed over substantially his or her entire body, or at least a very large portion of it, to artificial light from an electric lamp or a similar source generating light having a significant ultraviolet component. While this mode of treatment has been effective, it is less than optimal. In recent times patients and physicians have become increasingly aware of the undesirability of unnecessary exposure to ultraviolet light. Ultraviolet light causes damage to the skin and premature aging; it is also associated with melanoma and skin cancer. Additionally, conventional phototherapy treatment is implemented over an extended time and requires the patient comply to a regimen involving frequent visits to the physician before experiencing even slight improvement in his or her condition. Following such regimen is inconvenient to the

patient as well as costly; furthermore treatment often fails due to lack of compliance to this regimen. Thus, what is needed is a treatment for psoriasis and other skin disorders that minimizes side effects such as the risk of melanoma and skin cancer and that effectuates a rehabilitation of disease tissue expeditiously.

### SUMMARY OF THE INVENTION

[0009] One aspect of the invention comprises an apparatus for treating diseased skin with ultraviolet (UV) light. The apparatus comprises a source of UV light within the range of 300 and 315 nanometers and a cooler for cooling the diseased skin.

[0010] Another aspect of the invention also comprises an apparatus for treating diseased skin tissue with ultraviolet UV light. This apparatus comprises a source of high intensity ultraviolet light equal to or greater than about 1 minimum erythema dose (MED) in the wavelength range of between about 300 and 315 nanometers having an output for emitting the UV light and a cooler capable of cooling said diseased tissue.

[0011] Still another apparatus for treating an area of diseased epidermal tissue with ultraviolet UV light also includes a source of high intensity ultraviolet light equal to or greater than about 1 minimum erythema dose (MED) in the wavelength range of between about 300 and 315 nanometers having an output for emitting the UV light. This apparatus further comprises a conduit positioned to receive said ultraviolet light, said conduit having an output end that emits said UV light, a delivery device that includes the output end of the conduit, and a cooler in the delivery device. Preferably, the delivery device has a localized UV output sufficiently small to illuminate a portion skin no larger than said area of diseased epidermal tissue.

[0012] In another aspect of the invention, an apparatus for treating diseased skin with ultraviolet (UV) light comprises a source of UV light within the range of 300 and 315 nanometers having a plate comprising UV transparent cooling material with a cooler thermally contacted thereto.

[0013] In yet another aspect of the invention, an apparatus for treating diseased skin tissue with UV light comprises a source of UV light within the range of 300 and 315 nanometers having an output for emitting the UV light, wherein the source includes at least one conduit with at least one opening for connection to a source of coolant.

[0014] In still another aspect of the invention, a method for treating an epidermal region comprising diseased tissue includes cooling the diseased tissue and exposing the diseased tissue in the epidermal region to a dosage of ultraviolet light equal to or greater than about 1 minimum erythema dose (MED) in the wavelength range between about 300 and 315 nanometers.

### BRIEF DESCRIPTION OF THE DRAWINGS

[0015] **FIG. 1** depicts a plot on axis of wavelength (in nanometers) and effectiveness in arbitrary of the psoriasis action spectrum, human erythema action spectrum, and the action spectrum for DNA damage (i.e., carcinogenicity);

[0016] **FIG. 2** shows a block diagram of a preferred embodiment for treating skin disorders;

[0017] FIG. 3 depicts a schematic view of one embodiment of the present invention comprising a laser source, a coupling lens, and an optical fiber for exposing diseased skin to doses of UV-B wavelength (between about 290 to 320 nanometers) light sufficient to effectively treat skin disorders like psoriasis;

[0018] FIG. 4 is a schematic view of one embodiment of the present invention comprising an arc lamp, a reflector, a wavelength selection filter, and an optical fiber for treating skin disorders;

[0019] FIG. 5 depicts a schematic view of one embodiment of the present invention comprising a plurality of fluorescent lamps, a reflector, and a filter for directing UV-B wavelength light to the diseased skin;

[0020] FIG. 6 shows one example of a laser system employed to direct UV-B wavelength light of sufficient energy to effectively treat skin disorders like psoriasis;

[0021] FIG. 7 shows a delivery device that forms a part of the apparatus depicted in FIG. 1;

[0022] FIG. 8 is an exploded view depicting internal views of the delivery device of FIG. 2;

[0023] FIG. 9 is an exploded view showing parts of the delivery device shown in FIG. 3;

[0024] FIG. 10 is an end view showing a delivery end of the delivery device of FIG. 2;

[0025] FIG. 11 depicts a control panel used to control the apparatus of FIG. 1;

[0026] FIG. 12 shows a minimum erythema dose (MED) template usable with the apparatus of FIG. 1;

[0027] FIG. 13 depicts ink being applied to the delivery device of FIG. 2 by an ink pad;

[0028] FIG. 14 illustrates how the delivery may be used to deliver therapy in a "tile mode";

[0029] FIG. 15 shows how the delivery device may be used to deliver therapy in a "paint mode."

[0030] FIG. 16 shows a delivery device that additionally includes a plate and a thermoelectric cooler attached to the plate to provide cooling thereto;

[0031] FIGS. 17 and 18 are front and cross-sectional views of the chilled plate of FIG. 16; and

[0032] FIG. 19 depicts a delivery device that includes a jet that provides cooling.

#### DETAILED DESCRIPTION OF THE PREFERRED EMBODIMENT

[0033] Deleterious effects of various skin disorders including atopic dermatitis, dyshidrosis, eczema, lichen planus, psoriasis, and vitiligo can be ameliorated by directing high doses of ultraviolet light onto areas of skin affected by the disorder. The effectiveness of this technique utilizing ultraviolet light depends in part on wavelength, dosage, and what region of skin is exposed to the ultraviolet light.

[0034] Light within a specific range of wavelengths has been determined to be both effective in rehabilitating diseased skin and also in avoiding harmful side effects such as cancer and erythema (i.e., sunburn). This wavelength range

coincides with a spectrum conventionally known as UV-B, which extends in wavelength from approximately 280 or 290 to approximately 315 or 320 nanometers. The wavelength of light that is most successful at treating affected skin areas without causing harmful side effects is defined with reference to action curves **1000**, **1002**, **1004** for psoriasis, for erythema and for carcinogenicity, which are shown in FIG. 1. Psoriasis afflicted tissue can be effectively rehabilitated with light having wavelengths between approximately 300 to 310 nanometers. As shown by the psoriasis action spectrum curve **1000**, light having a wavelength spectrum between about 295 or 300 and about 320 or 325 nanometers can be effective in healing the tissue as well, but to a lesser extent. Incidence of erythema and skin cancer, as shown by the respective action spectrum curves **1002**, **1004**, however, increases in general for shorter wavelengths in this range between 295 and 325 nanometers. Risk of skin cancer, for example, is significantly higher for wavelengths at and below about 295 to about 300 nanometers than for wavelengths above this range. Erythema is also more readily produced by light having a wavelength of 290 nanometers than light between about 300 to 310 nanometers in wavelength. Therefore, to provide optimal treatment preferably diseased skin on a patient is exposed to light having wavelength that maximizes a likelihood of healing of diseased tissue yet minimizes risk of erythema and DNA damage, i.e., cancer. Accordingly, light ranging, for example, between about 295 to about 315 or 320 nanometers and more specifically, between about 300 to about 310 nanometers is preferred.

[0035] High, not low doses of light within these preferred ranges of wavelength have been determined to be most desirable. Diseased skin exposed to high doses of light heals quicker, that is, a fewer number of high dose treatments are required in comparison to conventional, low dose phototherapy treatments. Significant advantages derive from reduction in number of treatments. Since less treatments are necessary for high dose treatments, the total quantity of UV-B light to which skin is exposed to achieve healing is substantially smaller than for low dose treatments. This dosage can be quantified in total number of photons, or in total amount of energy such as in units of Joules. For example, preferably at least about 500 milliwatts (mW) of light having a wavelength of between about 304 and about 310 nanometers is directed onto the diseased tissue. It is well known that the risk of cancer and skin damage depends on the total number of photons or amount of UV-B radiation directed on the skin. Thus, by raising the dosage in a single treatment and thereby reducing the number of treatments, the overall UV light exposure and thus the risk of cancer and other skin damage is lowered. Additionally, lower number of treatments may also provide a higher degree of compliance of a patient to an otherwise difficult regimen involving a significant number of visits to the physician. Such a simplification in treatment is favorable as patients are less willing or able to adhere to a regimen involving multiple treatments per week for months.

[0036] In light of the foregoing reasons, doses as high as a patient can tolerate are preferred. More particularly, dosages at least as high as 1 minimum erythema dose (MED) have proven to be extremely advantageous. As defined herein a minimum erythema dose or MED corresponds to the minimal dosage at which a noticeable change in color occurs with distinct edges. The amount of energy necessary

to induce redness varies from patient to patient and depends on many factors including race, age, and skin color. Consequently, in treating a particular patient, a level of localized exposure equivalent to 1 MED can be determined for the patient. This level of exposure may be characterized by fluency or the amount of energy delivered to a defined area in, e.g., Joule/cm<sup>2</sup>. Diseased tissue is thereby exposed to doses at least as high as that dose that creates a change in color bounded by distinct edges on healthy skin is applied. Exposure of 1 MED or higher, i.e., doses of about 2 to about 4 or even to about 6 or 8 MED are effective in remedying the diseased condition. Moreover, a direct correlation has been also observed between occurrence of blisters and particularly successful treatments. For example, levels of exposure to UV radiation as high as 16 to 20 MED, cause UV radiation burns that produce blisters on the skin. However, only a single treatment at this exposure level is necessary to rehabilitate the diseased tissue. Thus, employing dosages that cause UV radiation burns accompanied by blistering appear to yield successful single treatment phototherapy. For these dosage levels, however, the patient must necessarily be able to endure the blistering.

[0037] Although the amount of energy that corresponds to 1 MED depends on the skin characteristics of the specific patient, for effective treatment of skin disorders like psoriasis, the recommended fluency of light having wavelengths distributed between about 300 and about 310 nanometers has been determined to range between about 10 millijoule/square centimeter (mJ/cm<sup>2</sup>) to about 4.0 Joule/square centimeter (J/cm<sup>2</sup>). More specifically, the range of fluency preferably ranges between about 100 mJ/cm<sup>2</sup> to about 1.8 J/cm<sup>2</sup>, and more preferably between about 600 mJ/cm<sup>2</sup> and about 1.2 J/cm<sup>2</sup>. Accordingly, doses as high as 500 mJ/cm<sup>2</sup>, 1 J/cm<sup>2</sup>, and 1.5 J/cm<sup>2</sup> of light having wavelengths at least as large as 300 nanometers but less than or equal to about 310 nanometers may be employed to treat skin disorders. Less doses of shorter wavelength light are required in comparison to longer wavelength of light. For example, fluencies in a range of about 50 mJ/cm<sup>2</sup> to about 1 J/cm<sup>2</sup> of light with a center wavelength of about 305 nanometer (e.g., between 304.5 and 305.5) may produce similar results as fluencies ranging from about 300 mJ/cm<sup>2</sup> to about 4 J/cm<sup>2</sup> of light having a wavelength centered about 310 nanometers (e.g., between 309.5 and 310.5). The action spectrum for erythema **1004** dictates in part how the required dose varies with wavelengths. As shown in the action spectrum **1004** depicted in FIG. 1, erythema is more readily induced by shorter wavelengths than longer wavelengths. In particular, the erythema response is about ten times stronger for light having wavelength centered about 305 nanometers (e.g., between 304.5 and 305.5) than for light centered about 310 nanometers (e.g., between 309.5 and 310.5). (Note that effectiveness as plotted in FIG. 1 corresponds to the degree the tissue is affected by one joule of optical energy.)

[0038] Since high doses of ultraviolet light enhance the risk of skin cancer and erythema as well as cause other skin damage generally associated with premature aging, the extent of a patient's epidermis to which light is directed must be limited. Since the diseased tissue needs to be exposed, light is not delivered to regions of skin other than affected areas, which particularly with psoriasis, are more tolerant to higher doses of light within the preferred wavelength regions than is healthy tissue. In treating psoriasis, for example, the UV light is preferably directed onto the

lesional as well as surrounding paralesional tissue, which although appearing normal is diseased tissue. Treatment, however, should be restricted only to these affected areas of skin, and areas uninvolved are preferably not exposed to the ultraviolet light. Certainly, the patients entire body is not subjected to the ultraviolet light as is true in some conventional phototherapy treatments. Instead, the ultraviolet light must be delivered to each separate affected region of the body. By avoiding treatment of unaffected portions of skin, the dosage can be raised well above conventional dosages as the affected areas will tolerate substantially higher doses without increased risk of side effects. Accordingly, the high doses of UV illumination are directed to an area on the skin that is preferably less than about 3000 cm<sup>2</sup>, more preferably less than about 1000 cm<sup>2</sup>, and most preferably less than about 500 cm<sup>2</sup>.

[0039] The temporal extent over which exposure occurs is also important. Exposure of the affected area to the UV light results in heating of the tissue. Unless this heat is sufficiently dissipated, thermal blistering will result. In particular, blisters are formed if the temperature of the skin is raised to about 50° C. Thermal energy absorbed by the exposed portion of skin, which may reach a depth between about 5 and 100 micrometers ( $\mu\text{m}$ ), must be conducted away from that region before it heats up the skin to excess. Specifically, the region should not heat up to the critical temperature of about 50° C. or more which would result in the formation of thermal blisters. Whether the thermal energy is sufficiently dissipated depends in part on the thermal time constant  $\tau_{\text{THERMAL}}$  of the skin, which governs the rate of heat dissipation. The rate at which thermal energy is introduced into the skin is also a relevant factor. Preferably, therefore, the high dose of energy provided by the UV light is distributed over a length of time greater than one or two times the thermal time constant associated with the removal of heat from the tissue. This duration of exposure may for example range between about 500 milliseconds (msec) and 1500 milliseconds for radiation delivered at 308 nanometers at fluences of less than 1 W/cm<sup>2</sup>. The illumination needs to be within a short enough time to be practical yet long enough to prevent blistering cause by thermal overload.

[0040] An excimer laser can generate short high power pulses of light having a wavelength of about 308 nanometers. These pulses can be high in power, e.g. about a half a million watts, but short in duration, for example, maybe lasting much less than 100 nanoseconds (e.g., 30 nanoseconds). The laser, however, may produce a plurality of such pulses at a repetition rate of about 200 Hz, i.e., one pulse per 5 milliseconds. Tissue exposed to a plurality of these short pulses will increase in temperature slightly with application of each pulse. The cumulative effect of the plurality of pulses being to raise the temperature of the tissue an amount that depends in part on the heat capacity of the tissue. The heat capacity is directly related to the thermal time constant  $\tau_{\text{THERMAL}}$  of the skin described above, which governs the rate of heat dissipation of heat from the skin after the series of pulses is complete. Preferably, therefore, the energy from the laser is spread over a long enough period of time with respect to the length of the thermal time constant  $\tau_{\text{THERMAL}}$  so as to permit sufficient dissipation to avoid excessive build-up of heat from the plurality of short pulses. Thermal damage caused by raising the temperature of the skin above, for example, the blister temperature of 50° C., can thereby be prevented. The amount of time required to expose the

affected tissue to the therapeutic doses of UV light, however, depends on the particular dose level.

[0041] This phototherapy treatment can be accomplished by utilizing an apparatus **1010** comprising an ultraviolet light source **1012** and a delivery system **1014** such as illustrated in block diagram form in **FIG. 2**. The ultraviolet source **1012** may comprise a laser, a lamp, or a solid-state device such as a light emitting diode. One or more of such light sources **1012** may be used alone or in combination with other similar or different light sources to produce light of sufficient intensity and at the appropriate wavelength to treat the skin disease. An excimer laser, and more specifically, a XeCl gas laser outputting light having a wavelength of about 308 nanometers, or an arc lamp or fluorescent lamp that provides radiation within the UV-B region are particularly suitable light sources for this application. A filter may be included to remove light outside the preferred wavelength ranges. This filter may comprise a dichroic or dielectric filter or a grating.

[0042] The delivery system **1014** may comprise a hand device that can be readily handled and moved to direct light onto the affected areas skin. Alternately, the delivery system **1014** may comprise a scanner possibly computer controlled, such as one that utilizes mirrors or reflective surfaces that move and thereby translate a beam of ultraviolet light extracted from the light source. A spatial light modulator, an optical component having a surface comprising a plurality of smaller regions each of which can independently be set to either transmit or block a portion of light incident on the surface of the modulator, may also be employed to appropriately distribute the ultraviolet light onto the patient's skin. Such spatial light modulators as are currently available, as well as those yet devised, include ones that switch mechanically, and ones that accomplish switching by altering the polarization of light passing therethrough.

[0043] The delivery system **1014** must be adapted to deliver the high dose to a target region of skin spanning between about 300 to 700 cm<sup>2</sup> or more preferably between about 400 and 650 cm<sup>2</sup>. Accordingly, the delivery system **1014** may include a focusing element such as a lens or mirror for focusing the optical beam down to a small region. Alternatively, the delivery system **1014** may have an aperture for egress of the UV light to limit beam size. For example, this aperture may be a square aperture with sides that restrict the size of the beam.

[0044] An optical path **1016** provided for example by an optical waveguide may channel light from the light source **1012** to the delivery system **1014**. This optical waveguide may comprise an optical fiber bundle including a plurality of fiber comprising material transparent to UV-B radiation such as quartz or fused silica. The optical fiber line **1016** may include a liquid filled optical guide such as shown in U.S. Pat. No. 4,927,231 issued to Jeffrey I. Levatter on May 22, 1990, which is incorporated herein by reference. This liquid filled optical guide is especially suited to transfer large amounts of optical power. The power-handling capability of the optical components within the apparatus **1010** are particularly important given that doses of 1 MED or higher are being applied to the patients skin.

[0045] In particular, the ultraviolet light source **1012** and the delivery system **1014** as well as the optical path **1016** need to handle power levels high enough to provide thera-

peutic doses of 1 MED or more. The prolonged duration over which the skin is exposed to the UV light, however, mitigates against the necessity for excessively high power requirements for these and other components in the apparatus **1010**. As discussed above, the energy density delivered to the patient is preferably in a range of about 205 to about 1200 mJ/cm<sup>2</sup>. However, to avoid blistering, the dosing with UV light is extended over a sufficiently long period of time so as to permit the thermal energy to be adequately dissipated. The power is optionally transported by a waveguide or with the aid of any other optical element and delivered by the delivery system **1014**. Other optical components such as lenses, mirrors, filters, grating etc. in the optical path of the UV light directed onto the patient must also be adapted to handle the levels of power sufficient for successful treatment of the patient.

[0046] As discussed above, the apparatus **1010** must be adapted to provide doses of UV light over short intervals, e.g., between about 0.5 and 1.5 sec in duration. Such periodic dosing can be provided by including a switch, a modulator, or a shutter within the path of the beam of UV light. For example, electro-optical and acousto-optical modulators, electro-optical and magneto-optical switches, as well as other optical devices that deflect, block, or otherwise interrupt the UV light output from the apparatus can be employed to prevent UV light from reaching the epidermis of the patient. Other alternatives include switching the light source on and off. Optical output from a solid state device such as a laser diode or a light emitting diode can be electrically controlled; accordingly such UV light sources **1012** can be intermittently activated so as to expose the patient over brief intervals. As discussed above, some light sources inherently produces pulsed output. Short pulses of light, for example, are emitted from pulsed lasers or pulsed lamps. Pulsed lasers and lamps that produce UV light are particularly suitable UV light sources. Other UV sources as well as other methods that yield short pulses of UV light for dosing a patient may also be appropriate for use in conjunction with the apparatus.

[0047] As discussed above and shown in **FIG. 3**, the UV light source **1012** may comprise a laser **1020** such as an excimer laser. Preferably, the laser **1020** comprises a XeCl laser that emits light having a wavelength centered about 308 nanometers. Like lasers well known in the art, the laser **1020** includes a gain medium (not shown), e.g. gaseous XeCl, surrounded by two mirrors (not shown), one substantially entirely reflective and the other that is partially transmissive. One end **1022** of an optical line **1024** comprising a waveguide in the form of for example a single optical fiber, an optical fiber bundle or a light pipe, is juxtaposed proximal to the partially transmissive mirror, another distal end **1026** of the optical line **1024** being attached to a delivery device **1028** comprising a hand piece **1030**. A coupling lens **1032** is inserted between the partially transmissive mirror and the optical guide line **1024**. The handpiece **1030** also includes a lens **1034**.

[0048] Light emitted by the laser **1020** is coupled into the optical line **1024** via the coupling lens **1032**. This light propagates through the optical line **1024** substantially without absorptive loss and on into the handpiece **1030**, which can be manipulated by the user to direct the UV light onto the portion of the patient's epidermis designated for treat-

ment. The lens **1034** within the handpiece **1030** focuses the UV light onto a small region **1036**, one for example between about 1 and 4 cm<sup>2</sup> in size.

[**0049**] In one embodiment, proximal end **1022** the optical line **1024** may have a circular cross-section **1038** while the distal end **1026** has a square or rectangular cross-section **1039**. The lens **1034** in the handpiece **1030**, preferably comprising fused silica, images the square or rectangularly shape distal end **1039** of the optical line **1024** onto the skin of the patient. Accordingly, the region of the skin that is illuminated comprises an area having a square or rectangular shape. The irradiance may be uniform over this square or rectangular area **1036** so as to enable the user to provide a uniform dose to a large area of diseased skin (i.e., larger than the image of the distal end **1026** of the optical line **1024**) by employing two methods described below that are herein referred to respectively as the paint and tile methods.

[**0050**] Utilizing a fiber bundle comprising a plurality of fibers as the optical line **1024** is preferable because the coupling lens **1032** cannot focus the UV light down to an area small enough for coupling the light into a single fiber having a small cross-section. In particular, the cross-section of the single fiber will be smaller than the cross-section of the beam even after focusing via the coupling lens **1032**. The light collected from the UV light source **1012** cannot be efficiently transferred into the single fiber and the amount of light that is coupled into the fiber is inadequate to provide an effective and reasonable treatment for skin disorders. The amount of energy that can be injected into the fiber, as well as into a optical fiber bundle, is equal to the product of the radiance from the light source **1012**, the cross-section of the fiber or fiber bundle where the light enters and the numerical aperture of the optical fiber or optical fiber bundle. Since conventional fused silica fibers generally have a numerical aperture of about 0.22, the cross-section of the fiber (or the fiber bundle) is the parameter that can be altered. In particular, this cross-section preferably has an area large enough to receive the entire focused beam from the coupling lens **1032**.

[**0051**] A fiber bundle is further advantageous, because it can offer a method for converting a beam profile having a circular cross-section, to one having a square or rectangular cross-section. The proximal end **1022** of the fiber bundle can be configured into a circular geometry, i.e., one having a circular cross-section, while the output end can be shaped into a square geometry with a square cross-section. This arrangement eliminates the need for a specialized optical component such as a specialized light pipe in the handpiece **1030** to act as a diffuser and/or beam shaper thereby reducing the weight and cost of manufacture of the handpiece and at the same time increasing its resistance to damage when dropped.

[**0052**] As discussed above, preferably, the laser **1020** is a pulsed laser. More preferably, the laser **1020** is an excimer laser such as a XeCl excimer laser and outputs light having a wavelength of about 308 nm. Alternatively the laser **1020** may comprise a solid state laser or a dye laser and may be supplemented with wavelength selective device such as one or more filters, gratings, or prisms. These filters may include dichroic or interference filters and may comprise dielectric or metal layers. The wavelength may also be controlled using optical components exploiting non-linear optical properties.

[**0053**] Additionally, the laser UV light source **1020** as employed for the above-described dermatological applications necessitate that certain performance requirements be satisfied. In particular, to be commercially successful, the apparatus **1010** preferably can operate for at least about one to three months without requiring servicing, a period during which, on average, a physician may treat between about 100 to about 300 patients. Treatment of a single patient may often involve dosing affected tissue, which altogether spans a large portion (e.g., 20 percent) of the patient's entire body, each individual dose, however, being administered over a localized region **1036** of skin, e.g., 1 cm<sup>2</sup> for a period in excess of the thermal time constant. Since UV light must be separately applied to potentially a large number of different sites on the epidermis, the laser needs to be activated for extended periods of time, e.g., between about 1 to 2 hours total for a single patient, and for between about 100 to about 600 hours for 200 patients over the three month period. Thus, the laser being employed for dermatological applications such as the treatment of psoriasis, atopic dermatitis, dyshidrosis, eczema, lichen planus, and vitiligo must have a sufficiently long lifetime so to offer a practical cost effective solution for handling such medical conditions.

[**0054**] In the case when the laser light source **1020** for these dermatological applications is an excimer laser, selecting the proper materials to be employed in constructing of the laser are critical. A suitable gas excimer laser such as an XeCl laser, for example, may comprise pressure vessel that contains a halogen gas, first and second electrodes for creating a laser discharge between the electrodes and generating a laser beam between first and second optical components, a fan for circulating the gases, and a heat exchanger for cooling the gas. By utilizing specific materials in fabricating the pressure vessel, the electrodes, the heat exchanger and the fan of the laser, its lifetime can be extended beyond 3600 hours. The criteria for selecting the appropriate materials for the laser can be found in U.S. Pat. No. 4,891,818 issued to Jeffrey I. Levatter on Jan. 2, 1990, which incorporate herein by reference. In particular, portions of the pressure vessel, first and second electrodes, fan and heat exchanger that are in contact with the halogen gas are fabricated entirely of a material that reacts with the halogen gas to form stable reaction products having a vapor pressure of less than 10<sup>-6</sup> torr at normal operating temperatures. According, the contamination of the gas by the pressure vessel, first and second electrodes, heat exchange, and fan is minimized and the lifetime of the excimer laser is increased. Electrically-conductive portions of the pressure vessel, first and second electrodes, fan and that exchanger that are exposed to the halogen gas may be formed of alumina, e.g. high purity alumina, while non-electrically-conductive portions of the pressure vessel, first and second electrodes, fan and that exchanger that are exposed to the halogen gas are formed of nickel, e.g., high purity nickel, stainless steel or aluminum, e.g., polished aluminum or polished stainless steel. By utilizing these types of materials that reacts with the halogen gas to form stable reaction products having a vapor pressure of less than 10<sup>-6</sup> torr at normal operating temperatures, an excimer laser light source can be realized that is suitable for dermatological applications, i.e., that can withstand extensive usage over an extended period of time of from about one to three months.

[**0055**] As discussed above and shown in **FIG. 4**, the light source **1012** may comprise a lamp **1040**, in particular an arc

lamp, such as a mercury arc lamp, like Model No. 69175 made by Osram Sylvania Products Inc., 275 West Main Street, Hillsboro, N.H. 03244. Other lamps **1040** that produce ultraviolet radiation in the range of between about 302 to 310 nanometers include germicidal lamps available from Philips Lighting Co., 200 Franklin Square Drive, Somerset, N.J. 08875, deuterium arc lamps, which emit much of their energy below 300 nanometers and require additional filtering, and metal halide lamps, e.g., those available from Fusion UV Systems Inc., 910 Clapper Road, Gaithersburg, Md. 20878. Another alternative includes zirconium arc lamps available from Osram Sylvania Products Inc., which emit substantial amounts of energy in the 302 to 310 region of the electromagnetic spectrum from a small volume.

[**0056**] In the apparatus **1010** shown, a reflector **1042** having a reflective surface **1044** is located on one side of the arc lamp **1040**. The reflector **1042** may have a spherically, parabolically, or ellipsoidally curved surface **1044** that is reflective for UV wavelengths of light preferably between about 300 to about 315 nanometers and that has an optical axis which passes through the arc lamp **1040**.

[**0057**] On an other side of the lamp **1040** is a UV filter **1046** such as an interference or dichroic filter followed by a focusing lens **1048** and delivery device **1014** that includes an optical fiber bundle **1050**. Preferably, the filter **1046**, focusing lens **1048**, and fiber bundle **1050** are located on the optic axis of the reflector **1042**. Note that in place of the reflector **1042**, a lens (not shown) comprising e.g., fused silica, can be employed to collect light from the arc lamp **1040** and instead of the filter **1046**, a prism or grating may be utilized for wavelength selection. For example, two passes through a diffraction grating in series can be used to select a narrow bandpass at any location on the lamp emission spectrum with the advantage of being wavelength-stable over broad operating temperature ranges and over production numerous runs. Alternatively, two identical 302 nanometer dielectric filters stacked consecutively may narrow the spectrum; however dielectric filters operating near their cut-on edge are sensitive to changes in temperature and also vary from one production run to another.

[**0058**] The delivery device **1014** may comprise a handpiece **1052** which has an output tip **1054** and that contains the optical fiber bundle **1050**. A disposable or sterilizable tip **1056** may prevent the output tip **1054** from contacting the patient. The fiber bundle **1050** may comprise silica, quartz, or a liquid filled fiber optic. The fiber bundle **1050** has one end **1058** which may serve as the output tip **1054** of the handpiece **1052** or may be imaged and/or focused onto the patient with another lens (not shown) in the handpiece. This end **1058** of the fiber bundle **1050** may be square or rectangular so as to produce a square or rectangular beam profile that is directed onto the patient in order to facilitate administration by the physician or health care provided a uniform coverage over the affected tissue.

[**0059**] Light from the arc lamp **1040** is collected by the reflector **1042** whose curved reflective surface **1044** is preferably dichroic and reflects predominantly light having wavelengths between about 300 to about 315 nanometers or 300 and 310 nanometers. Light from the arc lamp **1040** radiates toward the reflective surface **1044**, reflects therefrom and through the dichroic filter **1046**. A portion of the light is also radiated from the arc lamp **1040** and toward the

filter **1046** directly. This radiation also passes through and is filtered by the dichroic filter **1046**. Radiation from the arc lamp **1040** that is transmitted through the filter **1046** reaches the focusing lens **1048** which couples it into the optical fiber bundle **1050** where it exits therefrom at the output tip **1054** of the handpiece **1052**. This light is directed onto the patient. Preferably, the lamp **1040** outputs sufficient power such that after losses within the apparatus **1010**, approximately 0.5 to 2.0 W of power exits from the handpiece **1052** and is directed onto the patient.

[**0060**] The optical filter **1046** or filters are used to restrict treatment to a band between about 300 and 315 nanometers. Lamp energy below 300 nanometers is strongly rejected by the optical filter(s) **1046** to prevent erythral burning and/or carcinogenic effects. Lamp energy above 315 nanometers induces a sensation of heating and is also removed by filtering to ensure patient comfort. Employing broadband light, such as for example that includes wavelengths between about 300 and 315 nanometers, as opposed to using a single intense spectral line, e.g. the 312 nanometer line, captures a substantial percentage of the UV energy emitted by the arc lamp. Limiting treatment to only a single narrow line such as the 312 nanometer line is not preferred as the phototherapy response to this line is nearly twenty times less than the response for light having a wavelength of 302 nanometers. Advantageously, a spectral band of between about 302 to 315 nanometers exploits the higher phototherapy response of the shorter wavelengths such as between about 302 and 305 nanometers as well as the higher spectral emittance obtained for wavelengths ranging between about 305 and 315 nanometers. The apparatus **1010** with a mercury arc lamp, for example, therefore has the potential of treating a much larger area of skin in the same amount of time as an XeCl laser if large lamps or efficient optical collectors are employed.

[**0061**] As depicted in **FIG. 5**, the light source **1012** may comprise a bank or group **1070** of small fluorescent lamps **1072** such as the Philips CLEO compact lamp or the Phillips TL 40W/10R, which emits a moderate amount of energy in the range of between 300 and 310 nanometers; both lamps are available from Philips. The bank **1070** of fluorescent lamps **1072** is sandwiched between a reflector **1074** located on one side and a lens **1076**, here, a fresnel lens located on an opposite side of the lamps. The reflector **1074** comprises a plurality of curved reflective surfaces **1078**, one associated with each of the fluorescent lamps **1072** in the bank **1070**. These curved reflective surface **1078** may have cross-sections that form a segment of a circle, a parabola or an ellipse. Adjacent the fresnel lens **1076** is a wavelength selective filter **1080** followed by another lens **1082**, here a small refractive lens having sufficient power and being properly positioned so as to provide focusing. An optical fiber bundle **1084** with an output tip **1086** is also included in the apparatus **1010**.

[**0062**] Ultraviolet radiation from the lamps **1072** is collected by the reflector **1074** and the fresnel lens **1076** and passes through a wavelength selective filter **1080**. The filtered light is focused onto one end **1088** of the optical fiber bundle **1084** by the focusing lens **1082** and is transmitted through the length of the fiber bundle and exits from the output tip **1086** of the fiber. The apparatus **1010** may be made quite small by employing small fluorescent bulbs **1072**. If the apparatus **1010** is sufficiently small and light-

weight, the fiber optic bundle **1084** can be eliminated and the apparatus **1010** can be aimed or scanned by the user over the patient's affective areas of skin.

[0063] Moreover, although each of the systems **1010** described above and depicted in FIGS. 3-5 may include optical fiber bundles, as indicated, the systems are not so limited. For example, single or plural optical fibers or light pipes and/or other waveguide devices can be employed. Alternatively, the UV light may propagate in free space over a path which may or may not be manipulated by optical elements located in that path.

#### EXAMPLE

[0064] Another example of an apparatus **10** suitable for delivering electromagnetic energy to treat a skin condition in a medical patient is depicted in FIG. 6. The apparatus **10** comprises an ultraviolet light source **12** and a delivery device **15**. A cable **17** connects the delivery device **15** to the UV light source **12** so that energy from the UV light source can be delivered through the delivery device to the skin of a medical patient. The apparatus **10** is powered from an external electrical power source through a suitable electrical cable (not shown), which plugs into a typical, grounded wall socket.

[0065] In a preferred embodiment, the UV light source **12** is a 308 nanometer XeCl excimer laser. The 308 nanometer energy output is within the UVB range (i.e., about 290 to 320 nanometers) of ultraviolet light which, as described above, is therapeutically useful in the treatment of psoriasis. This generator **12** produces ultraviolet light pulses with an energy content of about 15 millijoules per pulse. Individual pulses have a duration of about 30 nanoseconds (fall width at half maximum intensity) and the pulses are repeatable at frequencies between about 100 and 150 Hertz.

[0066] The UV light source **12** is contained inside a housing **20** with a front **21** and bottom **22**. One or more fans (not shown) assist in cooling the excimer laser by forcing air through air vents **23** on the exterior of the housing **20**. The UV light source **12** is movable on wheels or casters **25** on the bottom **22** of the housing **20**. Handles **27** on the front **21** of the housing assist in moving the UV light source **12**. A control panel **30** on the front **21** of the housing **20** allows a user of the system **10** to set and adjust the operating parameters of the UV light source **12**. Operation of the system **10** is controlled by a user by means of a foot pedal **31**, which can be placed on the floor adjacent the UV light source **12** and which is electrically coupled to the light source **12** by means of a foot pedal cable **34**. Operation of the system **12** to deliver therapy to a patient is described more fully below.

[0067] The delivery device **15** comprises a hand-held wand **32**. This wand **32** is optically coupled to the UV light source **12** by means of the cable **17**, which includes a fiber optic delivery cable **33** configured to conduct ultraviolet light emitted by the excimer laser down the cable to the wand. The optical fiber cable **33** in the cable **17** connect to the UV light source **12** at an output connection **35** on the face **21** of the housing **20**. A second return fiber optic cable **38** connects to a return connection **40** on the housing **20** in the vicinity of the output connection **35**. A calibration port **42** is also disposed on the front face **36** of the housing **20** and is sized to receive the wand **32** therein.

[0068] Exterior details of the hand-held wand **32** are shown in FIG. 7. The wand **32** comprises an elongate, generally cylindrical body member **45** that includes a connecting end **48** and a delivery end **50**. A clear plastic cylindrical shield **53** is insertable into the delivery end **50** of the wand. The end of the shield **53** opposite the body **45** of the wand **32** includes positioning nubs **55**, which are intended to bear against the patient's skin as energy is being delivered to the patient. The use and function of the positioning nubs **55** are described in more detail below. Preferably, the shield **53** is removable from the wand **32** and disposable, or at least conveniently sterilizable, so that the wand itself is reusable indefinitely between multiple patients.

[0069] Still referring to FIG. 7, the delivery cable **33** and return cable **38** connect to the connecting end **48** of the wand **32**. The cables **33**, **38** connect to the wand **32** through a pair of elastomeric connection boots **57**, which provide strain relief and guard against kinking of the delivery and return cables. A switch in the form of a pushbutton **60** selectively allows or prevents the emission of ultraviolet energy from the delivery end **50** of the wand **32**. The structure, function, and operation of the pushbutton **60** are described in more detail below in connection with FIG. 8.

[0070] FIG. 8 is an exploded view showing the constituent parts of the preferred embodiment of the wand **32** through which ultraviolet energy may be delivered to the skin of the medical patient. The wand **32** comprises a main body member **62** and a secondary body member **65**. The two body members **62**, **65** are held together by screws **68**. A spacer **70** maintains an appropriate separation between the main and secondary body members **62**, **65** near the connecting end **48** of the wand **32**.

[0071] A fiber optic delivery line **73** connects to the connecting end **48** of the wand **32** through one of the connection boots **57**. The fiber optic delivery line **73** is coupled to a fiber optic delivery connector **75**, which connects to a fiber optic delivery adaptor **77**, which is in turn screwed into a fiber optic delivery port **80** at the connecting end **48** of the wand **32**. These components direct ultraviolet energy from the UV light source **12** (see FIG. 6) and into the wand **32**. The ultraviolet energy travels through the wand **32** through a first light pipe or fiber bundle **82** to a shutter assembly **85**, the construction and functioning of which will be described in more detail below.

[0072] A second light pipe or waveguide **88** runs inside the wand **32** parallel and adjacent to the first light pipe or waveguide **82**. The second light pipe or waveguide **88** is optically aligned with a fiber optic return line **90**, which connects to the connecting end **48** of the wand **32** through fiber optic return adaptor **93** and a fiber optic return connector **95**. The fiber optic return line **90** is routed through a connection boot **57** and returns back to connect to the return connection **40** on the face of the UV light source **12** (see FIG. 6).

[0073] The second pipe or waveguide **88** may be narrower than the first light pipe or waveguide **82** because, while the first light pipe or waveguide must be of sufficient diameter to transmit ultraviolet energy of considerable power for effective treatment, the second light pipe or waveguide only transmits a very small amount of energy reflected from the patient's skin back to a detector (not shown) inside the UV



light source 12 (see FIG. 6). While energy is being transmitted, energy will be reflected from the patient's skin and detected by the detector. Failure of the detector to detect energy reflected from the patient's skin during energy delivery will most likely indicate a blockage along the light path or some other problem with the delivery or generation system. In that case, the equipment will cease energy delivery and an error message will be delivered to the operator.

[0074] During energy transmission, ultraviolet energy from the generator 12 travels through the wand 32 to a shutter assembly 85 inside the wand. Details of the shutter assembly 85 are shown in FIG. 9. The assembly comprises a shutter plate 96, which includes structure defining a relatively large delivery aperture 97, and a relatively smaller return aperture 100. An upper tab 103 at the top of the shutter plate 96 fits into a slot (not shown) in the underside 105 of the pushbutton 60. A shutter plate pin 107 holds the upper tab of the shutter plate 96 in place in the slot of the pushbutton. A compression spring 110 is fitted onto a spring post 112 on the underside of the pushbutton.

[0075] The operation of the shutter assembly 85 can best be appreciated by referring once again to FIG. 8, in which the shutter assembly is shown in relation to the other components of the wand 32. A lower tab 115 at the bottom of the shutter plate 96 fits into a slot 116 in a shutter plate retainer 118, which fits into a receiving space 120 within the main body member 62 of the wand 32. The shutter plate retainer 118 is held within the receiving space 120 by a retaining rod 125 and a retaining sleeve 127, or by other suitable means. A tactile feedback member 130 fits within the receiving space 120 just below the shutter plate retainer 118.

[0076] When the user wants to deliver ultraviolet energy to a patient's skin, the user presses down on the pushbutton 60, thereby compression the compression spring 110 against a shelf 132, which partially overlies the receiving space 120 inside the main body member 62 of the wand 32. As the pushbutton is pressed her, the lower tab 115 on the bottom of the shutter plate 96 extends through the slot 116 in the shutter plate retainer and presses down against the tactile feedback member 130. The tactile feedback member is made of spring steel or a similar suitable material and is configured to produce a "snap" or "click" that is readily noticeable by the user when the pushbutton is fully depressed.

[0077] When the pushbutton 60 is fully depressed, the delivery aperture 97 and the return aperture 100 of the shutter plate 96 will be aligned with the first light pipe or waveguide 82 and the second light pipe or waveguide 88, respectively. A pathway is thereby created for ultraviolet energy in a therapeutic amount to travel down the first light pipe or waveguide 82 and through the delivery aperture 97 towards the delivery end 50 of the wand 32. A second pathway is formed simultaneous for the return of reflected energy from the patient, through the return aperture 100, back along the second light pipe or waveguide 88, and ultimately back to the UV light source 12 (see FIG. 6), where the reflected energy will be detected as a return signal by a detector (not shown) inside the UV light source.

[0078] When the user releases the pushbutton 60, force from the compression spring 110 returns the shutter plate 96 to a position in which the shutter plate prevents energy from the first light pipe or waveguide 82 from exiting the wand

32. A second pathway is formed simultaneous for the return of reflected energy from the patient, through the return aperture 100, back along the second light pipe or waveguide 88, and ultimately back to the UV light source 12 (see FIG. 6), where the reflected energy will be detected as a return signal by a detector (not shown) inside the UV light source.

[0079] When the user releases the pushbutton 60, force from the compression spring 110 returns the shutter plate 96 to a position in which the shutter plate prevents energy from the first light pipe or waveguide 82 from exiting the wand 32. This is a safeguard against accidental release of ultraviolet energy in the event of unintentional activation of the UV light source 12. Should energy be generated inadvertently, the energy will be blocked from exiting the device 15 unless the user has depressed the pushbutton.

[0080] When the UV light source 12 is activated with the pushbutton 60 depressed, ultraviolet energy emerges as a beam from the first light pipe or waveguide 82 and travels towards the delivery end 50 of the wand 32. After the beam crosses the shutter plate 96, it enters a lens in the wand 135. From the lens 135, the beam travels through an aperture plate 138, which gives the beam a square cross-section with well-defined edges suited for delivering uniform and well-controlled therapy to the patient. The lens 135 and aperture plate 138 are housed within an optics shell 140 and held inside the optics shell by a retaining ring 142, with the optics shell retained inside the wand 32 by a set screw 145.

[0081] Although the pushbutton 60 with aperture plate 138 connected thereto enables the user to further control the application of UV light from the UV light source 12, this feature is not necessary. The apparatus 10 may rely on other arrangements for regulating the short bursts of UV light output therefrom. Many types of light sources, including lasers and flash lamps, can be adapted to output optical pulses of varying duration. Alternatively, electro-optical, magneto-optical, acousto-optical, and even all optical switches and modulators, as well as electrically or magnetically activated mechanical modulators or shutters may be suitably employed to switch the UV output from the apparatus 10 on and off.

[0082] Referring still to FIG. 8, the cylindrical clear plastic shield 53 is inserted into the delivery end 50 of the wand 32. The shield 53 bears against an edge 147, which ensures that the positioning nubs 55 on the end of the shield are at proper distance from the lens 135 inside the wand 32. Additionally, the shield 53 is keyed so that the nubs 55 are aligned with the corners of the aperture plate 138, so that the corners of the beam impact the patient's skin substantially at the inner corners of the nubs when the therapy is delivered to the patient. The shield 53 may be keyed for proper insertion into the wand 32, e.g., by the provision of a ridge and a corresponding slot on the wand and the shield.

[0083] Soft pads 150 are affixed to the positioning nubs 55 on the end of the plastic shield 53. The shield 53 is sized and positioned so that the corners of the beam are positioned substantially at the nubs 55 on the clear plastic shield. To ensure that the nubs 55 are positioned accurately, the material of the shield 53 must be a substantially rigid material. The soft pads 150, which in the preferred embodiment are a relatively soft biocompatible silicone, are affixed to the nubs 55 of the shield 53 to enhance the patient's comfort and avoid injury where the shield contacts the patient's skin. The

soft pads **150** also serve to pick up and transfer to the patient's skin small quantities of a suitable biocompatible ink. This assists the caregiver in uniformly applying the ultraviolet energy in a technique that will be described in more detail below. The soft pads **150** may be affixed to the nubs **55** with a suitable adhesive or by any other appropriate means.

[**0084**] **FIG. 10** is a view, end-on, of the disposable shield **53** in place on the delivery end **50** (see **FIG. 8** of the wand **32**). **FIG. 10** also shows the shield nubs **55** that carry the soft pads **150**, as well as the aperture plate **138** that forms part of the wand optics. As noted above, the optics of the device **15**, and in particular the lens **135**, are designed so that the energy beam emerging from the wand **32** has a square-cross section whose corners coincide with the positions of the soft pads **150** on the nubs **55**.

[**0085**] **FIG. 11** is a frontal view showing details of the control panel **30** on the front **21** of the UV light source **12** (see **FIG. 3**) and through which the operator interacts with the apparatus **10**. The control panel **30** includes a power indicator **153** in the form of a green lamp that is lit whenever power is supplied to the generator unit **12**. Adjacent the power indicator **153** is another green lamp that serves as a ready indicator **155**, and which is lit when the unit is ready to deliver laser energy through the wand **32**. A lasing indicator **158** in the form of an amber light illuminates while laser energy is being generated and delivered through the wand **32**. A large, red pushbutton serves as an emergency stop button **160**, which, when pressed, cuts power to the laser generator **12** thereby halting energy delivery through the wand **32**.

[**0086**] A display window **162** is provided with an LED or LCD display or similar means for communicating information to the operator of the system **10**. Four entry keys **165** are provided below the display window **162**. By operating these keys the operator can input data into the system **10**, e.g., through the use of menus and choices displayed to the operator through the display window **162**.

[**0087**] A master key switch **167** is located at the lower left corner of the control panel **30**. When the master key switch is off, no power is supplied to the system **10** and energy generation is disabled. Provision of a key to control this switch **167** is a security measure to limit use of the system **10** to authorized personnel. A master key switch indicator **170** is provided in the form of a green LED just above the master key switch **167**. The master key switch indicator **170** lights whenever the master key switch **167** is in the "ON" position.

[**0088**] A reset button **172** is operable to switch the system **10** into a "power-on/self-test/warm-up" ("OST") mode. The POST mode is entered automatically when the system **10** is first switched on, after a power interruption, or when the reset button **172** is pressed. In POST mode, the system **10** performs diagnostic tests to assure that its components are operating properly and warms up the laser, a process that takes approximately three minutes. A POST mode indicator in the form of a yellow LED above the reset button **172** lights when the system **10** is in POST mode.

[**0089**] A standby button **178** is located to the right of the reset button **172** on the control panel **30**. The system **10** enters a standby mode after the POST mode is completed and the

unit warmed up, when the operator presses the standby button **178**, or if two minutes elapses without energy delivery while the system is in any "treatment" mode, details of which are described below. The standby mode is a condition in which the system **10** is warmed up, operable, and ready to be switched into one of the treatment modes. Standby mode is indicated by a standby mode indicator **180** in the form of a green LED above the standby button **178**.

[**0090**] A MED ready mode button **183** is operable to switch the system **10** in the first of three treatment modes, the MED mode. The MED mode is a diagnostic mode in which the system **10** is operated to determine a patient's minimal erythema dose (MED). The MED mode is indicated by an MED mode indicator **185** in the form of a green LED located directly over the MED ready mode button **183**. Operation of the system **10** in MED mode is described in more detail below.

[**0091**] A treatment ready mode button **188** is located to the right of the MED ready mode button **183**. When the treatment ready mode button **188** is depressed, the system is usable in either of two therapeutic treatment modes: tile mode or paint mode. Selection of tile mode or paint mode is made by the operator with a treatment mode key switch **190** disposed just to the right of the MED ready mode button **183**. When the unit is in treatment ready mode, and hence in either tile mode or paint mode, a green LED **192** above the treatment ready mode button **188**, which serves as a treatment ready mode indicator, lights to indicate this condition. Like the master key switch **167**, the treatment mode key switch **190** requires a key for operation to guard against unauthorized or unintentional changes between the two therapeutic treatment modes. Operation of the system in tile and paint mode is described in more detail below.

[**0092**] The system **10** described above can be used advantageously to treat psoriasis in a medical patient by first using the system to determine that patient's minimal erythema dose (MED) and then by delivering therapeutic treatment to the patient based on that MED. Use and operation of the system **10** in such a way is described below for purposes of illustration.

[**0093**] The system **10** is first positioned and plugged into a suitable source of electrical power. The master key switch **167** (see **FIG. 11**) is switched on, the unit enters the POST mode, and the system **10** begins its self-test routine as the unit warms up. When the self-tests are completed and the unit is fully warmed up, the system **10** enters standby mode, in which it is ready for calibration, if needed.

[**0094**] If calibration is needed, the operator inserts the deliver end **50** (**FIG. 6**) of the wand **32** without any shield **52** (see **FIG. 7**) into the calibration port **42** (**FIG. 6**) on the front side of the UV light source **12**. The operator must then depress the pushbutton **60** on the wand **32** to open the path for laser energy to emerge from the wand. The operator then depresses the foot pedal **31** and the unit begins lasing. Laser pulses are delivered into the calibration port where the intensity of the pulses is measured to determine their power output. The laser's power is calibrated and adjusted automatically by the system **10** to ensure that the wand **32** delivers about fifteen millijoules of ultraviolet energy into the calibration port with each laser pulse. When calibration is complete, this will be indicated in the display window **162** on the control panel **30** (see **FIG. 11**), and the system **10** will return to standby mode.

[0095] The system is used in MED mode to determine the patient's individual MED. FIG. 12 depicts a MED template 195, which is a thin, flexible plastic sheet with six individually numbered MED template apertures 198 sized to receive the shield 53 at the delivery end 50 of the wand 32. The MED template 195 further includes marking holes 200 with cross-hairs for positioning the template on the patient's skin in a suitable location. The MED template 195 will be used to determine the patient's MED and should be taped in place on the patient's skin in an untagged region that is not normally exposed to sunlight, e.g., the back, stomach, or buttocks. The location should, moreover, be one that is not affected by the patient's skin disorder. To facilitate later repositioning of the MED template 195 in the same location, the patient's skin should be marked with a marker through the marking holes 200.

[0096] With the MED template 195 taped in an appropriate location on the patient's skin, the operator presses the MED ready mode button 183 to put the system 10 into MED mode. The operator aligns the shield 53 on the end of the wand 32 with the first MED template aperture 198 of the MED template 195. The soft pads 150 on the nubs 55 at the end of the shield 53 should rest lightly against the patient's skin to ensure that the wand 32 is the proper distance from the patient's skin. With the wand 32 properly positioned, the operator depresses the pushbutton 60 on the wand, and then operators the foot pedal 31 to initiate lasing. The system 10 operates automatically to deliver energy to the patient's skin in an amount equal to 100 millijoules per square centimeter.

[0097] The operator then moves the wand 32 to the second MED template aperture 198 and, again with the pushbutton 60 held down, operates the foot pedal 31. The system 10 adjusts itself automatically in MED mode to deliver a number of pulses sufficient to deliver 150 millijoules per square centimeter to the skin under the second cutout. The operator repeats the process with the system automatically adjusting to deliver standard MED determination doses as follows:

MED TEMPLATE APERTURE NUMBER	MED DETERMINATION DOSE ENERGY (mJ/cm <sup>2</sup> )
1	100
2	150
3	200
4	250
5	300
6	350

[0098] Note that the system 10 increments the MED determination doses automatically without further input from the operator. Each MED determination is incremented and delivered in turn. The user need only ensure that the wand 32 is aligned properly with the appropriate MED template aperture 198. After the MED determination doses are delivered, the template 195 is removed, and the patient is then asked to return the next day for observation and determination of that patient's MED.

[0099] When the patient returns, preferably, about 24 hours after delivery of the MED determination doses, an identical MED template 195 is again placed over the patient's skin with the help of the marks made previously. A

patient's MED is defined as the minimal dosage at which a noticeable change in color occurs with distinct edges. The practitioner notes and specifies the patient's MED in terms of the number (1-6) of the MED template aperture 198 that corresponds to the lowest MED determination dose for which this distinct color change occurs.

[0100] After the patient's MED has been determined the patient's physician selects a "treatment multiplier." The system 10 is programmed to accept treatment multipliers in the form of integer numbers between e.g., two and eight or two and sixteen or twenty. The inventors have found that a treatment multiplier of two provides mild but nevertheless effective therapy, while a treatment multiple of eight provides more aggressive and generally more effective therapy while still remaining within acceptable safety limits. Intermediate treatment multipliers produce intermediate effects.

[0101] After the patient's MED has been determined and a treatment multiplier chosen, the user may begin delivering therapeutic treatment. The user should also adjust treatment mode key switch 190 to select between tile mode and paint mode. When the user place the system 10 in treatment ready mode by depressing the treatment ready mode button 188, the system 10 will prompt the user to enter the patient's MED and the preselected treatment multiplier.

[0102] In tile mode, the system 10 will operate automatically to deliver a number of energy pulses equal to one therapeutic does each time the foot pedal 31 is pressed by the user. The therapeutic dose is equal to the patient's MED, as determined previously, multiplied by the preselected treatment multiplier. Thus, for example, if the first color change with distinct edges was noted corresponding to the third MED template aperture number, the patient's MED will have been found to be 200 millijoules per square centimeter. If a treatment multiplier of six is selected, the system 10 will operator to deliver a number of pulses corresponding to 1200 millijoules per square centimeter each time the foot pedal 31 is pressed.

[0103] The user will then move the wand 32 stepwise over the patient's psoriasis, stopping at multiple locations to press the soft pads 150 of the shield 53 lightly against the patient's skin. At each location, the user will operate the foot pedal 31 and pushbutton 60 to deliver one therapeutic dose before moving on to the next location. The user will repeat this process until substantially the entire area of the patient's psoriasis has been treated.

[0104] An ink pad 203 bearing a quantity of an appropriate nontoxic ink may be provided to assist the user in covering the entire treatment surface uniformly in tile mode. As depicted in FIG. 13, the shield 53 at the end of the wand 32 may be pressed lightly onto the ink pad so that the soft pads 150 at the ends of the shield numbs 55 pick up a small quantity of the ink.

[0105] As suggested by FIG. 14, when the soft pads 150 are pressed against the patient's skin, the ink on the soft pads (see, e.g., FIG. 10) will mark the patient's skin at the location of the nubs 55. As described above, the optics of the system 10 are such that the nubs 55 correspond to the comers of the treated area. The user may the move the wand 32 step-wise, aligning the soft pads 150 at a treatment location with comer marks of a previous location and delivering therapy at each location until substantially the entire area of

the patient's affected skin is treated. FIG. 14 shows corner marks 205 formed by ink from the soft pads arrayed in a "tile" pattern across the patient's skin over an area of diseased tissue. When treatment is completed, the user should switch the system 10 to standby mode by pressing the standby button 178 on control panel 30.

[0106] Paint mode differs from tile mode in that therapy is delivered as the wand 32 is swept more or less continuously over the treated surface rather than at multiple discrete locations as is the case in tile mode. Paint mode is similar to tile mode in that before initiating treatment, the user will first enter the patient's MED and the preselected treatment multiplier as described above.

[0107] In paint mode, the user moves the wand 32 over the entire treated area in patterns suggested by FIG. 15. To ensure complete coverage, the user first moves the wand 32 in the horizontal pattern 207, the user then repeats the motion using the vertical pattern 210. In each pattern, the user may move the wand 32, for example, at a rate of two square centimeters per second. The unit will automatically generate laser pulses at a rate appropriate to deliver the desired therapeutic dose over the course of the two treatment passes.

#### Test Results

[0108] Efficacy of a system 10 and method similar to the one described above in treating psoriasis was evaluated in an investigative clinical trial. Thirteen patients were enrolled in the clinical trial. Each of the trial subjects had psoriasis manifesting itself in the form of multiple stable plaques. Stable plaques were defined as plaques that had been present and essentially unchanged for at least eight weeks prior to the patient's enrollment in the study. Patient's enrolling in the study were required to cease all topical therapy for at least two weeks prior to treatment in the study, systemic therapy for at least eight weeks, and phototherapy and photochemotherapy for at least four weeks.

[0109] The clinical study was conducted with apparatus 10 substantially the same as that described above. Each patient's individual minimal erythema dose (MED) was determined by exposing the patient's skin to a set of controlled response calibration doses. The response calibration doses were applied to unexposed gluteal skin not affected by psoriasis. The UV light source 20 comprising a laser and the delivery device 15 used in the study generated a beam of ultraviolet light having a circular cross-section with an area of 4.91 cm<sup>2</sup> (2.5 cm in diameter). Each patient received eight different calibration doses —100, 140, 280, 400, 560, 800, 1120, and 1600 millijoules delivered over the 4.91 cm<sup>2</sup> area of the beam.

[0110] The patient's response to the response calibration doses was observed 24 hours after the calibration doses were delivered. Each patient's individual MED was defined as the minimum calibration dose at which a color change with well defined edges was observed. Individual MEDs were determined by observing each patient's unique response to the response calibration dose.

[0111] After an MED was determined for each patient, a tightly controlled and closely observed regimen of therapeutic treatments was conducted on the subjects. Four similarly appearing plaques of adequate size were selected

for each patient. Originally, it was intended that ultraviolet light would be delivered to six different locations on each of the four plaques in doses equal to 0.5, 1, 2, 4, 8, and 16 times the patient's individually determined MED. Thus, it was intended that each patient would receive therapy at 24 different locations, six locations in each of four plaques.

[0112] All of the plaques were intended to receive identical therapeutic doses. Each plaque, however, was intended to receive therapy according to a different treatment schedule. The first plaque would receive a single treatment, the second plaque two treatments, and the third plaque four. The fourth plaque was to receive 20 treatments. Treatments to the fourth plaque were administered twice weekly with a 72-hour interval between each administration. The 20 twice-weekly treatments were thus given over a 10-week period.

[0113] The patient's skin was marked at the time of therapy with indelible ink at each treatment site for subsequent identification. The patients were observed and evaluated at 2-week intervals during the 10-week treatment period, and at two, four, and six months after the treatment ended.

[0114] When the study began, response calibration doses in the amounts noted above were administered first to each of the thirteen patients. The patients' responses to the calibration doses were observed, and individual MEDs were determined for each patient. Ultraviolet light delivery then began for purposes of therapy.

[0115] When the first three subjects were treated, it was observed that dosages of 8 and 16 times the patient's MED caused blistering at the treatment site within twenty-four hours of administration. It was therefore decided that the treatment regimen should be modified to include delivery doses of 0.5, 1, 2, 3, 4, and 6 times the patients' MEDs. These doses were well-tolerated by all the subjects, with some slight erythema observed in some subjects at 4 and 6 MEDs. This erythema was occasionally accompanied by a moderate burning sensation, in which case treatment at these doses was temporarily omitted.

[0116] Repeated doses at 0.5 and 1 MED did not significantly alleviate the psoriasis. However, repeated exposures at between 2 and 6 MEDs did result in significant improvement by approximately 8 weeks following 2 treatments, 6 weeks following 4 treatments, and 3-4 weeks with 20 treatments. It was noted that after the blistering had healed in the three patients who received doses of 8 and 16 MEDs, the patient's psoriasis had cleared at those sites as well.

[0117] This method for treating skin disorders including but not limited to psoriasis and vitiligo can be improved by cooling the skin to be treated prior to and/or during application of high doses of narrow band UV light to the affected area of the skin. Cooling can be accomplished, e.g., by spraying the skin with a cool liquid, gas, or air or by applying a cool object to the affected area of skin. Cooling reduces the degree of injury to the patient that would ordinarily result from exposure to such elevated levels of LTV light and thus permits higher doses of UV light to be administered. For example, when a pulsed source such as a pulsed laser is employed, cooling counters the build up of thermal energy with a series of pulse so that high temperatures associated with injury to the epidermis are not reached. Cooling may also remove heat, slowing the accumulation

and the rise in temperature with application of the plurality of pulses. Heat can then be dissipated under normal thermal dissipation processes that occur over times exceeding the thermal dissipation time constant  $\tau_{\text{thermal}}$ . Cooling may also establish a low temperature as the starting point from which the skin begins to heat up as thermal energy accumulates with each additional pulse. By preventing tissue damage and thereby enabling higher fluences of UV light, the total number of treatments can be reduced and remission can be improved. Cooling can also permit more frequent treatments if necessary. The affect of cooling on the skins response to UV light is more fully described in "Influence of Temperature on Ultraviolet Injury" R. Freeman, J. Knox, Arch. of Derm., Vol. 89, June 1964.

[0118] To reduce UV damage, the surface of the tissue to be treated is preferably cooled to about 5° C. or below, and more preferably to about 0° C. just prior to and/or during application of the UV radiation. The greater the degree of cooling, the higher the tolerance to the dose without injury; thus temperatures of about -5° C. or less may improve results of UV treatment. The low temperature limit is set by the amount of cooling that will damage healthy skin in the proximity of the disease tissue. At a minimum, the diseased skin must be cooled to a temperature substantially lower than the normal temperature of skin, the normal temperature of skin being about 34° C.

[0119] Cooling can be accomplished by applying a chilled UV transparent substrate 2210 such as shown in FIGS. 16-18 to the area of skin to be treated. This cooled substrate or plate 2210 may comprise, e.g., sapphire, quartz, fused silica, borosilicate glass, or any glass or other material that is transparent to UV light in the preferred wavelength range for treatment and that can withstand the cooling. To simplify the treatment procedure for the healthcare provider, this cooled substrate 2210 may be incorporated in and connected to a device 2015 used to deliver IN radiation from a UV source to a localized region of skin that includes the diseased tissue. This substrate 2210, for example, may be attached to a wand 2032 similar to the one depicted in FIGS. 6-10 and having a rectangular output aperture 138 shown in FIGS. 8 and 10 at the end 2050 where UV light is emitted for delivery to the patient. As most clearly shown in FIGS. 17 and 18, the plate 2210 is circular and has oppositely facing circularly shaped surfaces 2212, 2214, one proximal and one distal to the output aperture 138 of the wand 2032. The plate 2210, and more particularly, the opposing circularly shaped surfaces 2212, 2214, have a spatial extent greater in size than the rectangular output aperture 138 of the wand 2032 so that light forming a beam and exiting the output aperture will be fully contained within the circular surfaces of the plate as it passes through them. The plate 2210 is mounted on the shield 2053 such that the distal surface 2214 forms an exterior surface of the delivery device 2015 for unrestricted access to the epidermis of the patient; that is, no other surface on the wand 2032 or device prevents the distal surface from fully contacting the patient's skin.

[0120] A thermoelectric cooler 2216 having a plurality of cooling leads 2218 is mounted on the plate 2210 such that the cooling leads are firmly connected to and form good thermal contact with the proximal surface 2212 of the plate. Adhering the thermoelectric cooler 2216 to the plate 2210, and more particularly to one of the circular surfaces 2212, 2214 of the plate, is convenient as both circular surfaces on

the plate provide large areas for accommodating the cooler and its cooling leads 2218. Mounting the cooler 2216 on the distal surface 2214 of the plate 2210 is less desirable as the distal surface is preferably freed of any obstructions that would limit good thermal contact between the cooling plate 2210 the patient's skin. Such irregular features on the distal surface 2214 of the plate 2210 would, in addition, likely inhibit smoothly scanning this chilled plate across a patient's skin. However, to the extent that such limitations could be avoided, the cooler can be located on the distal surface 2214 or on other surfaces of the cooling plate and/or of the wand 2032 e.g., on the shield 2053. However, by selecting a location for the cooler 2216 such that a substantial portion of the cooling leads 2218 touch the cooling plate 2210, the cooling plate can be efficiently cooled.

[0121] Electrical wires 2220 run through the wand 2032 and to the thermoelectric cooler 2216 to provide electrical power for cooling the leads 2218. These electrical wires 2220 connect to the wand 2032 through an elastomeric connection boot 2021, which offers strain relief and guards against kinking and which is mounted on the wand 2032 adjacent one other elastomeric connection boot 2057 that receives an optical cable 2033 for delivery of UV light. A return optical cable is not included in this embodiment. The thermoelectric cooler 2216, including the cooling leads 2218, and the electrical wires 2220 to the wand 2032 can be affixed to the wand 2032 in a conventional manner such as for example with the aid of an adhesive.

[0122] The chilled substrate 2210 is to be employed with the apparatus 1010 described above which offers significant advantages in treating skin disorders and which comprises a source 1012 of UV radiation and a delivery system 1014. The chilled substrate 2210, for example, may be used in connection with a laser-based system 1010 such as depicted in FIG. 3 that contains a laser 1020, possible computer controlled, that is optically coupled to a hand piece 1030 via a flexible guide 1024. The laser 1020 may comprise an excimer laser outputting light having a wavelength of about 308 nanometers while the hand piece 1030 might resemble the wand 2032 shown in FIG. 16. In one specific embodiment, the laser 1020 can be energized for up to 300 pulses in about a second and the wand 2032 distributes about 10 millijoules per pulse (mJ/pulse) output from the 308 nanometer excimer laser over an area of approximately 3 cm<sup>2</sup> at a target region of the epidermis. The UV beam applied to the diseased skin is not, however, limited to these specific fluency and size specifications but rather may range widely as describe above. In particular, an area of skin greater than 3 cm<sup>2</sup> of skin may be cooled to about 0° C. when placed on the skin.

[0123] To treat a patient afflicted with a skin disorder responsive to UV light, the healthcare provider may position the wand 1032 over a diseased region of skin such that a substantial portion of the distal surface 2214 of the cooled plate 2210 is in physical contact with the diseased region. With the thermoelectric cooler 2216 activated, the area of skin touching the plate is cooled, preferably to a temperature below about 5° C., and more preferably to about 0° C. or less. Light emitted from the laser 1020 is coupled via the input cable 2033 into the wand 2032 and exits from the wand after passing through the rectangular aperture 138. This light propagates forward within a beam that is transmitted through the chilled plate 2220 and projected onto the skin

pressed against the distal end **2214** of the plate. A therapeutic dose of UV light is thereby directed onto the skin in accordance with the discussions above with regard to FIGS. **1-15**, but while the skin is cooled to a temperature lower than the normal temperature of skin. Substantially all of this dose of ultraviolet light is applied to the skin before the chilled plate warms up, that is, within a period of time shorter than the thermal time constant associated with the plate **2210**. In addition, the dose is preferably, although not necessarily, applied to only a fraction of the area of skin that is cooled. Likewise, the beam of light that exits the wand **2032** will likely illuminate only a portion of the chilled plate **2210**. For example, in the case of treating psoriasis, the beam may encompass both the psoriatic plaque and surrounding paralesional tissue as well as some adjacent healthy tissue, with both the plaque, the paralesional tissue, and preferably an additional peripheral region of healthy skin all being cooled.

[**0124**] Other arrangements for cooling the plate or substrate **2210** are included within the scope of the invention. In lieu of mounting a thermoelectric cooler **2216** on the surface **2212** of the plate, the plate **2210** may be cooled with fluid by providing a pathway for flowing a liquid or gas chilled to a desirably cool temperature across or through the plate. For example, hollow metal lines can be placed in thermal contact with the substrate **2210** and chilled water can be circulated through these lines to sufficiently lower the temperature of the plate. In addition, the plate **2210** need not be attached to the delivery device **2015** but may be separate and independent from the delivery device. For example, the UV transparent plate or substrate **2210** may be cooled in a refrigerator, or by immersing it in or contacting to or otherwise exposing it to a chilled liquid, solid, or gas prior to or while being placed on the patient's skin. The light can then be passed through the chilled plate **2210** in a manner described above. Similarly, an object formed into a shape other than a plate but having a temperature less than the temperature of the diseased skin, and preferably below about 5° C. or 0° C. can be employed to cool the skin and provide therapeutic results. The cool object need only be transparent to UV light of the wavelength employed for treatment and preferably comprise a material suitable for maintaining a cool temperature for a sufficiently long period and that is thermally conductive so as to readily absorb heat from the skin.

[**0125**] Alternatively, cooling can be accomplished by exposing the skin directly to chilled liquid or gas or cooled air, possibly in the form of a spray or stream ejected from jets **2222** incorporated in the wand **2032** depicted in FIG. **19**. These jets **2222** are formed by providing openings **2224** in channels **2226** for flowing liquid or gas coolant or cool air through the wand. In the wand **2032** depicted in FIG. **19**, portions of the channels **2224** for transporting the coolant are visible adjacent to and in contact with the UV shield **2053**. Other portions of the channels are in interior regions of the wand **2032** and are thus not visible from the perspective shown in FIG. **19**. A supply tube **2228** feeds the channels **2226** located within the wand **2032**. This supply tube **2228** is connected to the wand **2032** through the elastomeric connection boot **2022** mounted on the wand **2032** adjacent another elastomeric connection boot **2057** that receives the optical cable **2033** for delivery of UV light. As discussed above, these elastomeric connection boots **2022**, **2057** offer strain relief and guard against kinking.

[**0126**] The supply tube **2228** is connected at one end to a source of coolant (not shown) comprising, e.g., a supply of chilled coolant or cryogenics, and at another end to the channels **2224** traversing through the wand **2032**. These channels **2224**, which may be insulated, provide a pathway for the liquid or gaseous coolant from the supply tube **2228** to the openings **2224** in the portion of the channels located at the delivery end **2050** of the wand **2032**. These openings **2224** are oriented to direct the spray toward a region where light output from the wand **2032** is also incident. The jets **2222**, however, are preferably designed to spread the coolant over an area of the patient's skin that is larger than that portion illuminated by the beam of UV light. The coolant employed may comprise chilled water, chemical solutions sufficiently cooled, liquid or gas cryogenics such as freon, liquid CO<sub>2</sub> or liquid N<sub>2</sub>, or combinations thereof. Other possible coolants that are suitable for spraying on the patient's skin prior and/or during exposure to UV light include but are not limited to cool air.

[**0127**] Like the chilled substrate **2210**, the jet spray is to be employed with the apparatus **1010** for treating skin disorders described above comprising a source of UV radiation **1012** and a delivery system **1014**. The jet spray, for example, may be used in connection with an arc lamp-based system **1010** such as depicted in FIG. **4** and that contains an arc lamp **1040** optically coupled to a hand piece **1052** via a flexible guide **1050**. The system **1010** additionally includes a filter **1046** for limiting the wavelengths of light to a narrow band of UV preferably somewhere between about 300 and 315 nanometers and a reflector **1042** for collecting light emitted from the lamp. In one specific embodiment, the lamp-based system **1010** produces at least 1 watt (W) of UV radiation that is directed onto the patient's skin. The lamp **1040** is optically coupled by a lens **1048** to the UV light guide **1050**, which is connected to the handpiece **1052** or wand **2032**. A mechanical shutter **97** in the wand **2032** controls the flow the light output therefrom. This mechanical shutter **97** is connected to a multifunction trigger **2060** which is conveniently located on the wand **2032** depicted in FIG. **19** and which, when depressed, opens the shutter. One or more valves (not shown) situated in the channels **2226** may also be electrically or mechanically connected to the multifunction trigger **2060** such that the trigger, when depressed, also opens the valve.

[**0128**] To treat a patient afflicted with a skin disorder responsive to UV light, the healthcare provider positions the delivery end **2050** of the wand **1032** over a diseased area of skin such that the openings **2224** of the jets **2222** are in position to direct coolant onto a portion of skin including but not necessarily limited to the diseased area. The operator then depresses the trigger **2060** to allow the UV radiation from the lamp **1040** to pass through the wand **2032** and onto the patient's skin. The jets **2222** are also activated by the trigger **2060** on the wand **2032**. The coolant flows from reservoir through the supply tube **2228** into the channels **2226** in the wand **2032** and out the opening **2224** of the jets **2222**. Preferably, the coolant is pumped through the jets **2222** or the reservoir is a pressurized source of coolant such that the coolant is sprayed out of the opening of the jets and spreads onto the skin. The coolant spray cools on contact with the skin. Preferably, the spray cools the skin to a temperature below about 5° C., and more preferably to about 0° C. or less prior to and/or during exposure of the skin to UV light delivered by the wand **2032**. In the case where the

coolant comprises chilled liquid or gas, the low temperature of the coolant cools the skin, however, the coolant may provide additional cooling if the coolant evaporates upon or soon after contacting the skin.

[0129] In addition, the wand 2032 directs a therapeutic dose of UV light onto the skin in accordance with the discussions above with regard to FIGS. 1-15, however this dose is delivered while the skin is cooled to a temperature lower than the normal temperature of skin, i.e. about 34° C. As described above, the skin is preferably cooled prior to and/or during UV exposure and substantially all of the dose of UV light is applied to the skin before the skin warms up. Also, the jet spray preferably cools the skin faster than the skin receives the total integrated sum of UV radiation directed to one location. The skin is therefore sufficiently cooled prior to application of injurious doses of radiation to the skin, and thus, tissue damage is avoided or at least minimized. In addition, as previously mentioned, the dose is preferably, although not necessarily, applied to only a fraction of the area of skin that is cooled.

[0130] The technique of providing cooling is not limited to any one particular way of cooling the skin prior to and/or during exposure to suitable dosages of UV light having the appropriate wavelength. Rather, other methods and apparatus for cooling the plate or substrate 2210 are included within the scope of the invention. For example, cool air can be ejected from the jets 2222 or supplied by a circulating fan or blower. In addition, in cases, where jets 2222 are employed, the Venturii affect may be exploited to create a chilled zone. Alternatively, a UV transparent gel may be applied to the skin; the gel may be cooled before or after it is applied to the epidermis to achieve appropriate cooling. This gel may also aid in coupling the UV energy from the source 1012 to the skin by providing index-matching. In addition, many skin disorders such as psoriasis are accompanied by scaling and flaking of the skin. The cooling gel or fluid may also serve to wet this dead skin to allow more UV light to penetrate instead of being scattered by the scaling, flaking areas of skin.

[0131] Selection of the appropriate method of cooling may be influenced by the intended use and the anticipated frequency of use. Systems designed to treat small areas of diseased tissue such as psoriasis plaque modest in size, may suitably employ a cryogen spray, which is consumable. In contrast, a liquid cooled window with a re-circulating chiller may be more appropriate for treating larger areas of skin afflicted by, e.g., vitiligo or psoriasis, as fast and effective cooling can be provided without requiring a large supply of a consumable coolant.

[0132] As described above, cooling the skin increases the skin's tolerance to high doses of UV light. Higher doses of UV light can be applied to the skin without inducing tissue damage. With higher doses of UV light, the total number of treatments can be reduced, thereby lowering the cost of treating the skin disorder. Requiring less doctor visits also promotes patient compliance to an otherwise difficult regimen and improves the likelihood of success of the overall treatment.

[0133] Cooling also permits a higher frequency of individual treatment sessions. A typical treatment regimen may include three or more visits to the physician or healthcare provider to completely clear the disease. In an effort to avoid

injury, a subsequent session is not scheduled too soon as time is necessary to permit healing. Consecutive sessions, for example, should be separated by at least about 90 hours when suitable doses of 308 nanometer light are employed to treat the disease. The time between sessions, however, can be shortened by cooling the skin prior to and/or during the application of UV light as discussed above, i.e., if the skin is cooled during exposure to ultraviolet light, a subsequent treatment session can follow sooner. For these and other reasons, the UV treatment preferably includes cooling.

[0134] Thus, it has been demonstrated that psoriasis can be treated effectively by local administration of ultraviolet light in high doses. Since the patient's tolerance of and response to ultraviolet therapy varies significantly according to their individual skin types, it is highly advantageous to administer the therapy based on observed individual MEDs determined for each patient.

[0135] The therapy should be delivered at greater than one times the patient's MED per treatment. More preferably, the therapy should be delivered in doses of between 2 and 6 MEDs per treatment. Therapy may be delivered in a single treatment, but multiple-treatments may be preferred. Treatment may be delivered once, twice or four times. Treatment may also be delivered twice per week for ten weeks in succession. Cooling the skin prior to and/or while exposing the skin to the UV light can permit higher doses to be used thereby reducing the total number of individual treatment sessions. Cooling can also shorten the time between successive treatment sessions.

[0136] A preferred system 10 and methods for delivering phototherapy according to the invention has been described herein. Modifications and additions to this preferred method will no doubt occur to those skilled in the art. For example, although the method has been described as suitable for treatment of psoriasis, the method is not so limited, but rather may be effective in treating many other skin diseases as well. Further applications, additions and modifications may occur to those skilled in the art and the scope of the invention is not to be limited to the preferred embodiment described herein. Rather, the scope of the invention should be determined by reference to the following claims, along with the full scope of equivalents to which those claims are legally entitled.

What is claimed is:

1. An apparatus for treating diseased skin with ultraviolet (UV) light, the apparatus comprising:

a source of UV light within the range of 300 and 315 nanometers; and

a cooler for cooling the diseased skin.

2. An apparatus for treating an area of diseased epidermal tissue with ultraviolet UV light, the apparatus comprising:

a source of high intensity ultraviolet light equal to or greater than about 1 minimum erythema dose (MED) in the wavelength range of between about 300 and 315 nanometers having an output for emitting the UV light;

a conduit positioned to receive said ultraviolet light, said conduit having an output end that emits said UV light;

a delivery device that includes said output end of said conduit; and

a cooler included in said delivery device.

3. The apparatus of claim 2, wherein said delivery device has a localized UV output sufficiently small to illuminate a portion of skin no larger than said area of diseased epidermal tissue.

4. A method for treating an epidermal region comprising diseased tissue, the method comprising:

cooling the diseased tissue and exposing the diseased tissue in said epidermal region to a dosage of ultraviolet light equal to or greater than about 1 minimum erythema dose (MED) in the wavelength range of between about 300 and 315 nanometers.

\* \* \* \* \*