

March 6, 1956

J. SINKOVITZ

2,737,112

TWO REVOLUTION PRINTING PRESS

Filed Jan. 12, 1952

7 Sheets-Sheet 2

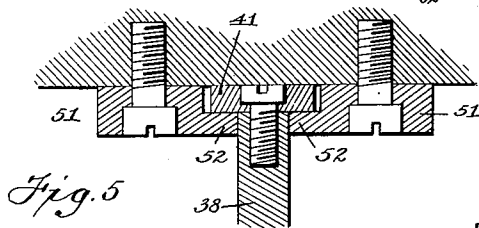
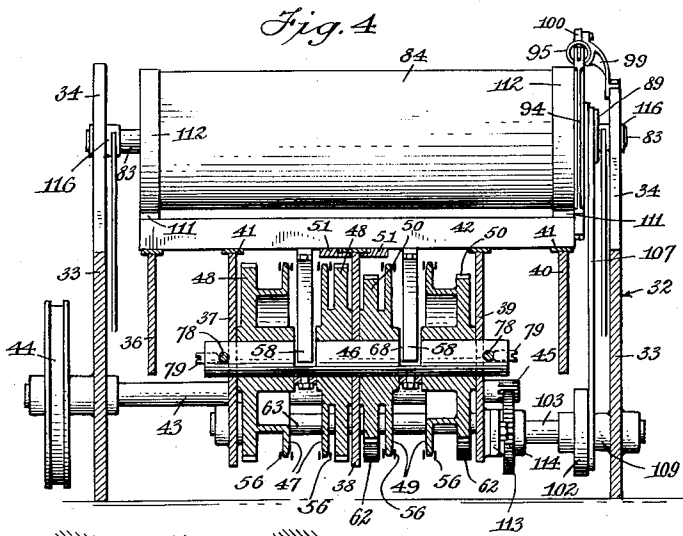
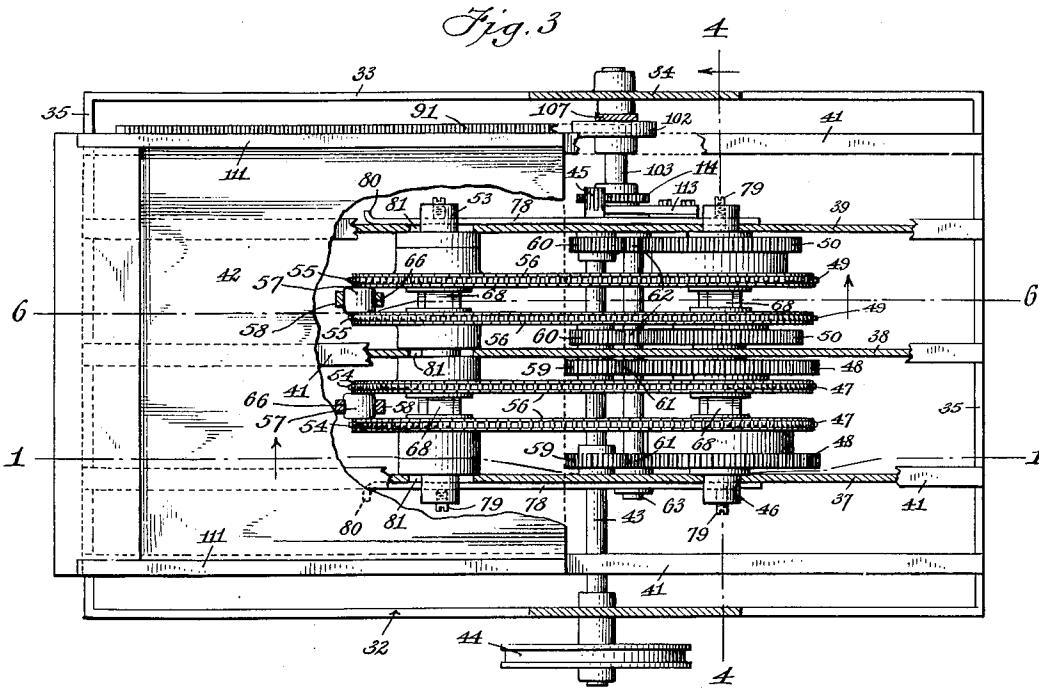

Joseph Sinkovitz, Inventor
By *Emil Stankov*
Attorney.

March 6, 1956

J. SINKOVITZ

2,737,112

TWO REVOLUTION PRINTING PRESS

Filed Jan. 12, 1952

7 Sheets-Sheet 3

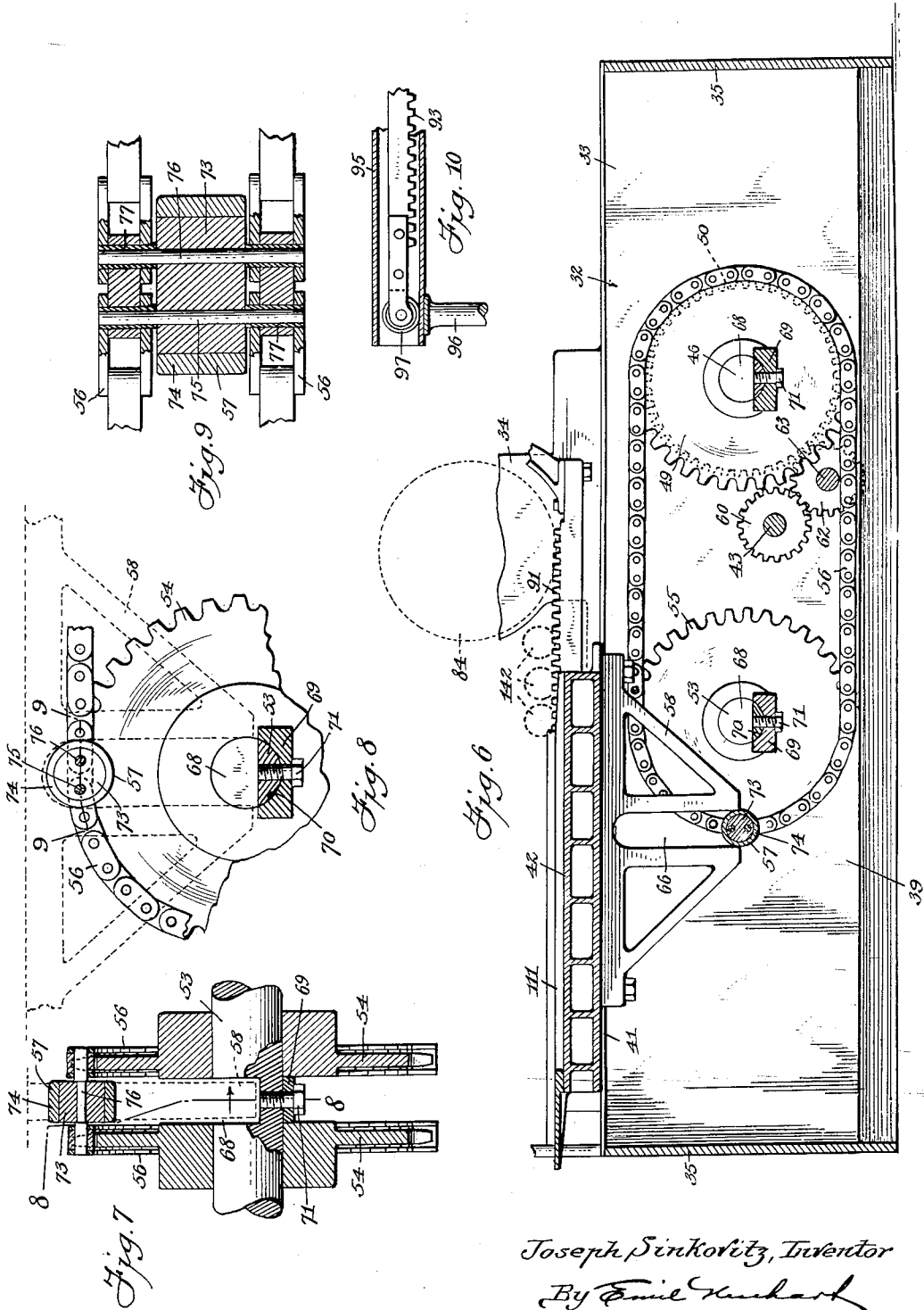

Joseph Sinkovitz, Inventor
By Emil Muehler
Attorney.

March 6, 1956

J. SINKOVITZ

2,737,112

TWO REVOLUTION PRINTING PRESS

Filed Jan. 12, 1952

7 Sheets-Sheet 4

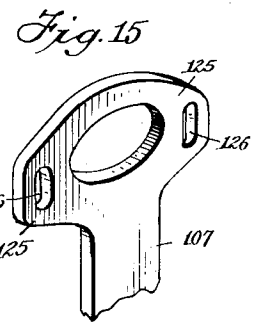
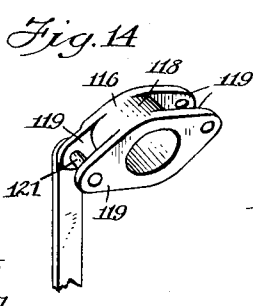
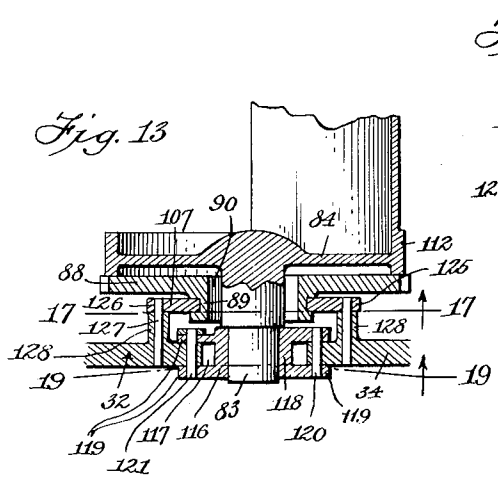
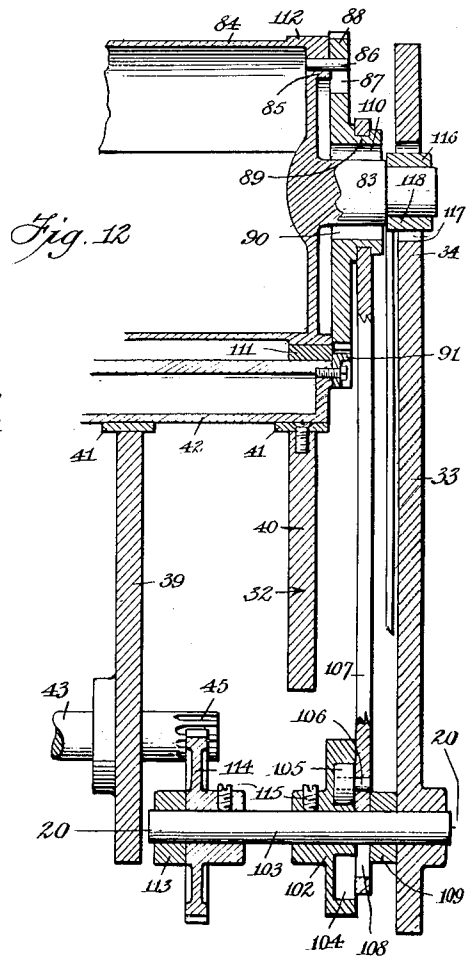
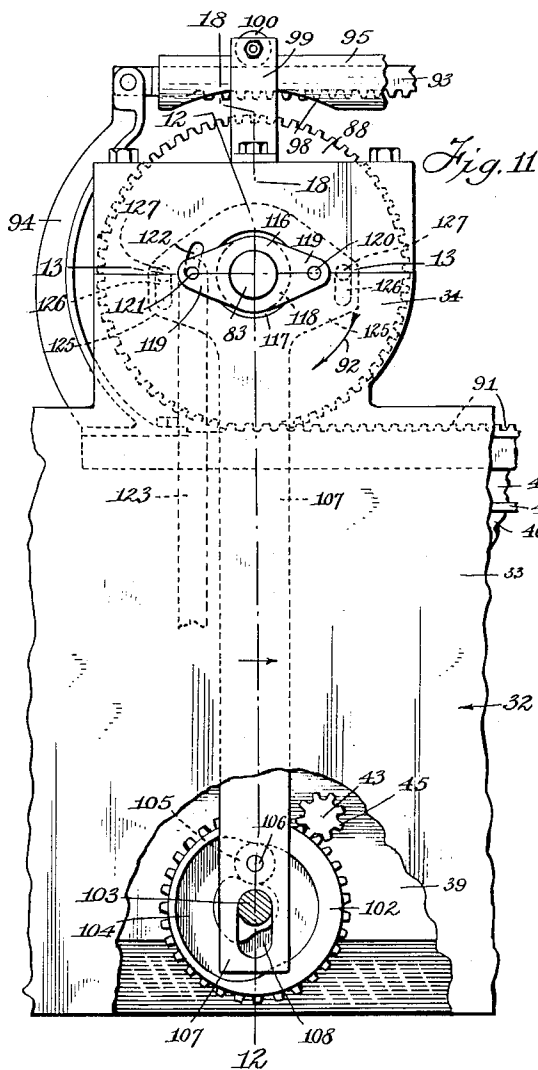

Joseph Sinkovitz, Inventor
By Emil Kaulark
Attorney.

March 6, 1956

J. SINKOVITZ

2,737,112

TWO REVOLUTION PRINTING PRESS

Filed Jan. 12, 1952

7 Sheets-Sheet 5

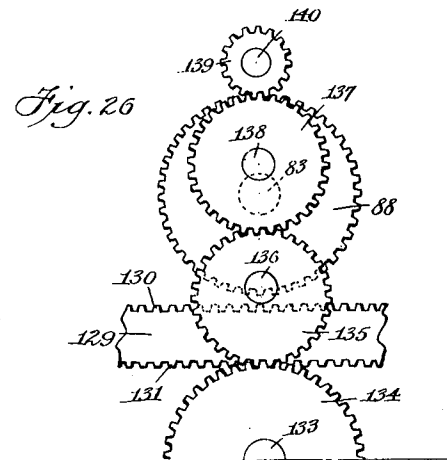
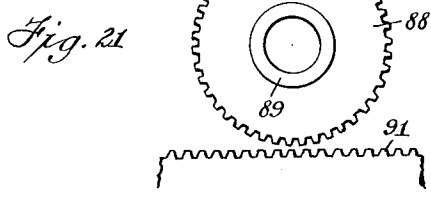
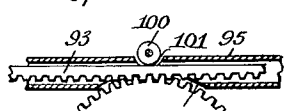
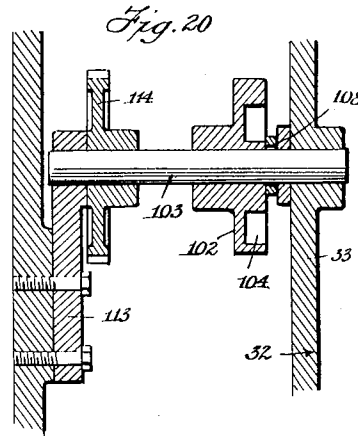
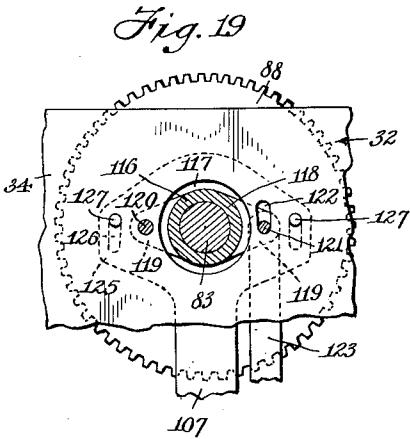
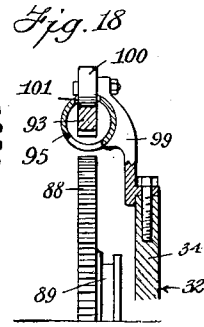
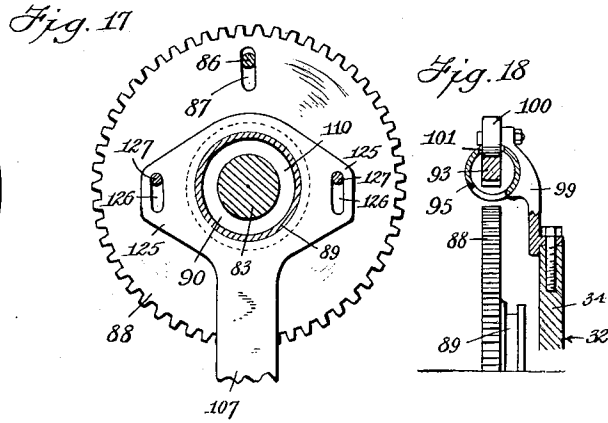
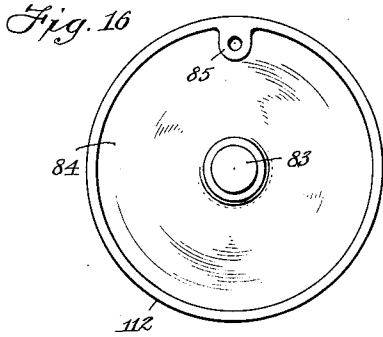

Joseph Sinkovitz, Inventor
By Emil Kuehler
Attorney.

March 6, 1956

J. SINKOVITZ

2,737,112

TWO REVOLUTION PRINTING PRESS

Filed Jan. 12, 1952

7 Sheets-Sheet 7

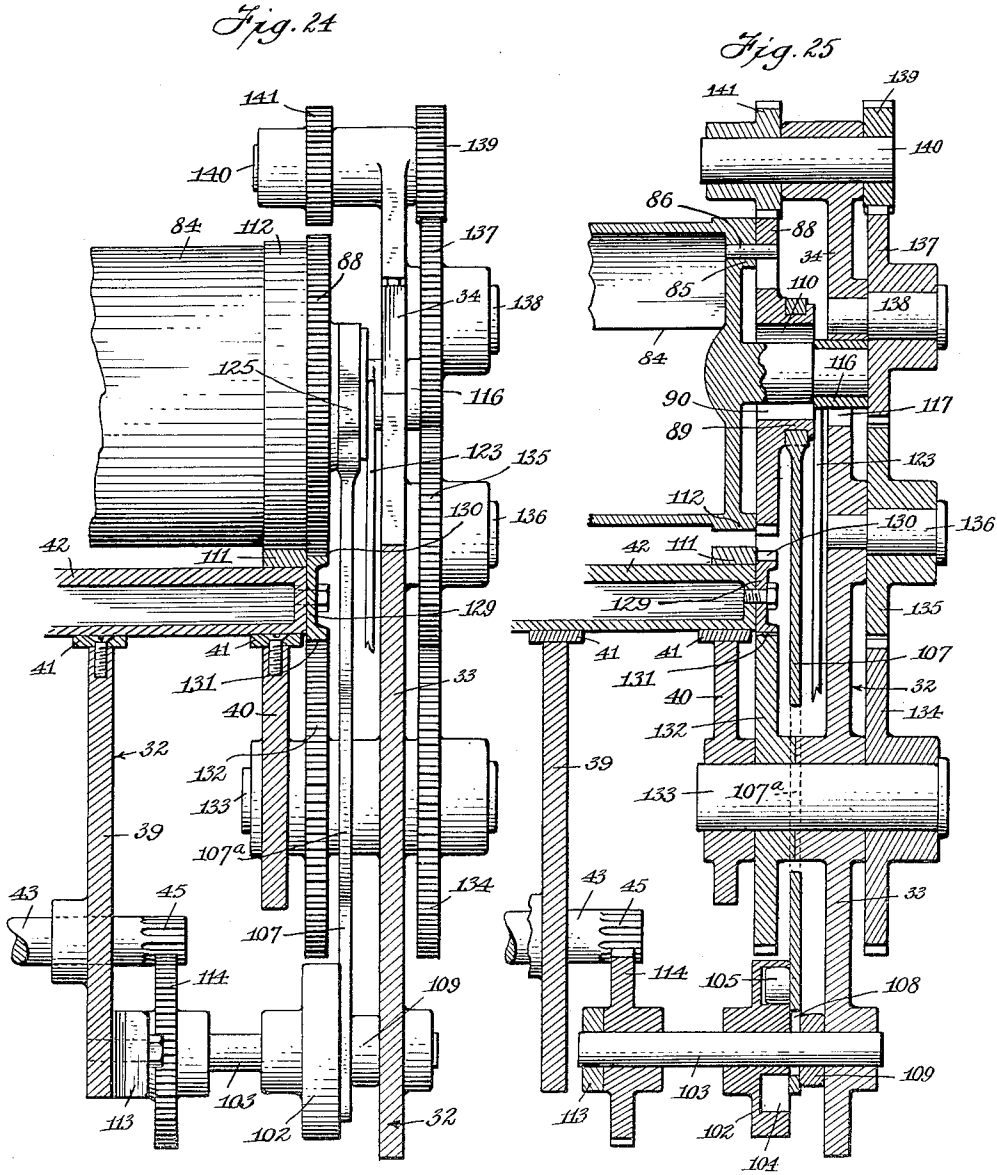

Joseph Sinkovitz
Inventor
By Emil Kuehler
Attorney.

1

2,737,112

TWO REVOLUTION PRINTING PRESS

Joseph Sinkovitz, Pittsburgh, Pa.

Application January 12, 1952, Serial No. 266,144

12 Claims. (Cl. 101—283)

My invention relates to a two-revolution printing press of the type wherein the bed bearing the printing type or other printing-medium and the impression cylinder are relatively movable, and particularly wherein the bed is reciprocally arranged underneath an impression cylinder.

Among the many objects of my invention, one is to so construct the press and improve the relative arrangement of the movable parts thereof that the form size of the press can be enlarged without increasing the overall size of the press and thereby permit the use of one or more additional form-inking rollers so as to enhance the quality of ink distribution; all extremely desirable features especially adaptable for a single two-revolution reciprocating bed type of press, and presses adapted for multi-color printing.

In explanation of the projects herein mentioned and to be mentioned it should be understood that good ink distribution depends mostly on the number of form-inking rollers used and in a press of the type herein shown and described, when three or four form-inking rollers are used, the printing form is invariably reduced in size for the reason that on most flat-bed printing presses, the impression cylinder is rotated at a constant speed and the form size consequently depends upon the distance of the bed travel at such speed which, in order to avoid smudging of the printed matter, must be the same as the surface speed of the impression cylinder. In present day presses of this type, the form usually ends at the line where the constant speed of the bed ends, which is known to be where the bed begins to slow down. The beginning of the printing form, known as the head line or gripper edge, begins near the vertical center line of the form ink-distributing roller farthest away from the impression cylinder when the bed is at the end of its printing or active stroke.

A further object of my invention is to drive the impression cylinder in synchronism with the movement of the printing bed, so that a perfect impression from the type or other printing medium carried by the bed will be assured over a greater length of the printing bed than would otherwise be possible.

A further object is to so construct the press that a cylinder of smaller diameter can be used than is possible in most flat bed printing presses; the circumference of such cylinder corresponding to the measurement of the stroke of the printing bed so that the cylinder and cylinder gear make one complete revolution during each bed stroke or two revolutions during a complete cycle of movement of the printing bed.

A still further object is to provide a press that includes a printing bed reciprocal on a suitable frame or foundation and one operated in forward position or under printing action from substantially a momentary position of rest under gradually accelerated movement, which position of rest is hardly apparent, and which position I hereinafter sometimes refer to as a neutral position, or more definitely a neutral point or line of transfer, until reaching its maximum accelerated speed, under which it

2

is advanced under constant or unchanging motion until it reaches a predetermined forward position, after which it is gradually decelerated until it substantially reaches a position of rest to complete its forward or printing stroke or one-half of its cycle of movement. The printing bed thence is gradually accelerated in movement and in reverse order travels idly through a constant accelerated speed until it reaches a predetermined position in its reversing or idle stroke and becomes gradually decelerated until it reaches its foremost position and completes its cycle of movement; and wherein, the impression cylinder is operated by said printing bed in exact synchronism with the movement of the bed.

A still further object of my invention is to provide a reciprocating printing bed, a rotatable impression cylinder and means to cause the cylinder to rotate in one direction only during a complete cycle of movement of the printing bed; said means including elements associated with the impression cylinder to raise the latter so as to clear the bed during the return or idle movement of the latter.

My invention further includes the method by which the foregoing and other objects to appear hereinafter are attained.

With the above and other objects of my invention in view, the invention consists in the method of operating and in the novel features of construction and arrangement of parts to be hereinafter described and more particularly pointed out in the sub-joined claims.

In the drawings:

Fig. 1 is a longitudinal section on an enlarged scale taken on line 1—1, Fig. 3, looking in the direction of the arrow crossing said line.

Fig. 2 is a top plan view of the press at the distant side thereof as viewed in Fig. 1.

Fig. 3 is a sectional top plan view of the sub-structure of the printing press, showing part of the printing bed and some of the tracks for the press broken away to illustrate parts underneath.

Fig. 4 is a transverse section taken on line 4—4, Fig. 3, looking in the direction of the arrow crossing said line.

Fig. 5 is a detailed section showing the means for retaining the printing bed in proper sliding position and preventing tilting movement of the bed.

Fig. 6 is an enlarged section taken on line 6—6, Fig. 3, looking in the direction of the arrow crossing said line; the impression cylinder and the form-inking rollers being shown in dotted lines.

Fig. 7 is a central vertical section through a portion of paired sprocket wheels and sprocket chains, showing the actuator bracket associated therewith in dotted lines; the section being taken axially through the actuator roller carried by said sprocket chains.

Fig. 8 is a sectional view taken on line 8—8, Fig. 7, looking in the direction of the arrow crossing said line; the actuator bracket being shown in dotted lines.

Fig. 9 is an enlarged section taken on line 9—9, Fig. 8.

Fig. 10 is an enlarged detailed sectional view through the post-supported end of the tube into which the return gear-rack is telescoped.

Fig. 11 is an enlarged side elevation of a portion of the printing press in which the impression cylinder is arranged; a portion of the side or outer frame member being broken away to illustrate parts in rear of the same.

Fig. 12 is a section taken on line 12—12, Fig. 11, looking in the direction of the arrow crossing said line.

Fig. 13 is a section taken on line 13—13, Fig. 11.

Fig. 14 is a detached perspective view of one of the cylinder bearings in which the ends of the trunnions at opposite ends of the impression cylinder are journaled; the same being shown associated with an actuating rod.

Fig. 15 is a detached perspective view of the upper end

of the gear shifting element adjustably mounted for actuating the gear wheel carried by the impression cylinder.

Fig. 16 is a view of one end of the impression cylinder.

Fig. 17 is a section taken on line 17—17, Fig. 13, looking in the direction of the arrow crossing said line.

Fig. 18 is a section taken on line 18—18, Fig. 11; the impression cylinder and the gear-shifting means being omitted.

Fig. 19 is a section taken on line 19—19, Fig. 13, looking in the direction of the arrow crossing said line.

Fig. 20 is a section taken on line 20—20, Fig. 12.

Fig. 21 is a diagrammatic view showing the cylinder gear and the actuating racks alternately engaged thereby.

Fig. 22 is a side elevation of the press, showing a modified form of cylinder-shifting and operating mechanism.

Fig. 23 is a top plan view of the near side of the press as shown in Fig. 22.

Fig. 24 is an enlarged transverse section showing the cylinder-shifting and operating mechanism illustrated in the modification shown in Fig. 22.

Fig. 25 is an enlarged section taken on line 25—25, Fig. 22.

Fig. 26, shown on sheet 5 of the drawings, is a diagrammatic view of the cylinder operating mechanism illustrated in Fig. 22.

Reference being had to the drawings in detail, the reference numeral 32 designates the frame of the printing press.

This frame may be variously constructed, but to accommodate the operating mechanism of the printing press in the form in which it is herein illustrated and described, it comprises side members 33 which include upward extensions 34, end members 35 and intermediate frame members 36, 37, 38, 39, and 40 which extend from end member to end member and vary in height. Each of the intermediate members has flat track strips 41 fastened to the upper edges thereof; said flat strips serving as tracks and being disposed at a right angle to the frame members to which they are attached so as to overhang opposite sides thereof. These flat members are screwed or otherwise fastened to the upper edges of the intermediate members, as shown in Figs. 5 and 12. Thus the track strips or tracks form rigid portions of the intermediate members and serve to slidably support a printing bed 42 which may be of any suitable construction to receive thereon or therein a type form or other printing medium from which a printed impression is to be made.

Suitably journaled in one of the side members 33 and in the intermediate frame members 37, 38, and 39 is a drive shaft 43 which shaft is therefore disposed transversely and extends outwardly from the frame at one side thereof and has a driving pulley 44 secured thereto around which a belt may be trained to operate said shaft. This drive shaft may be otherwise actuated, if desired. The other end of the drive shaft 43 terminates outside of the intermediate frame member 39 and is machined at this end to provide gear teeth 45 for the same, serving as a pinion.

Non-rotatably held within the intermediate frame members 37, 38 and 39 is a non-rotatable shaft 46 which is parallel with the drive shaft 43 and rotatably mounted on said shaft 46 between the intermediate frame members 37 and 38 is a pair of sprocket wheels 47 which are spaced apart, and rigid with—integral or otherwise—are gear wheels 48. Said sprocket wheels and gear wheels serve as part of bed-advancing mechanism for moving the printing bed through its printing stroke. Between the intermediate frame members 38 and 39 a second pair of spaced-apart sprocket wheels 49 is arranged which also have gear wheels 50 fixedly attached therewith by being integrally formed therewith or otherwise applied thereto; said sprocket and gear wheels 49 and 50 being also rotatable on the non-rotatable shaft 46 and serving as part of bed-reversing mechanism for moving the bed through its idle or return stroke.

The intermediate frame member 38 has track-retainers 51 engaging it, opposite overhanging portions of said retainers engaging the track-strip 41 attached to said frame member and having inward extensions 52 underlying and engaging the undersides of said overhanging portions. In this manner the printing bed is prevented from becoming dislodged or swaying laterally or endwise, thereby insuring a straight-lined movement for the printing bed over the several tracks or track-strips 41 provided at the upper ends of the intermediate frame members.

The non-rotatable shaft 46 is disposed in a plane somewhat above the plane of the drive shaft 43 and in rear thereof and a similar shaft 53 is non-rotatably held in the intermediate members 37, 38 and 39 a predetermined distance in rear of the drive shaft 43 and in the same horizontal plane therewith. On this shaft 53 two pairs of sprocket wheels 54, 55 are rotatably mounted; the pair of sprocket wheels 54 being longitudinally aligned with the pair of sprocket wheels 47 rotatable on the shaft 46 and the sprocket wheels 55 being similarly aligned with the sprocket wheels 49 on said shaft.

The longitudinally aligned sprocket wheels on the shafts 46 and 53 are therefore paired and sprocket chains 56 are trained around each pair of the sprocket wheels so paired. The sprocket chains at each side of the intermediate frame member 38 are employed in pairs spaced apart transversely to receive and support an actuator in the form of a roller 57 between them. When one actuator roller 57 is in its extreme rearward position it is harnessed to the bed and ready to move forwardly to effect the printing stroke of the printing bed, while the other actuator roller is also in its extreme rearward position and ready to move in a forward direction in idling or unharnessed relation to the bed. The sprocket chains may be termed oppositely-traveling endless elements.

The sprocket wheels 47 on shaft 46 are therefore arranged in pairs side by side or spaced apart transversely to suspend an actuator roller between them and the sprocket wheels 49 are also arranged in pairs and spaced apart in a similar manner for the same purpose, each sprocket wheel 47 being paired with a gear wheel 48 and each sprocket wheel 49 being paired with a gear wheel 50.

Secured to the underside of the printing bed 42 are two actuator brackets or yokes 58 so disposed that they are transversely aligned and travel between the two pairs of sprocket chains 56 and between the transversely paired sprocket wheels over which said sprocket chains are trained.

For the purpose of rotating the sprocket wheels 47 and 49 in opposite directions on the non-rotatable shaft 46, the drive shaft 43 has pinions 59 and 60 secured thereto, the pinions 59 being in mesh with the gear wheels 48, as clearly shown at 61 in Figs. 1 and 3, and the pinions 60 being in mesh with idler gears 62 on a jack shaft 63 parallel with the drive shaft 43. The drive shaft is rotated counter-clockwise, causing the gear wheels 48 to rotate clockwise or in the direction shown by the arrow 64 thereon in Fig. 1. The gear wheels 50 are of somewhat smaller diameter than the gear wheels 48, although the sprocket wheels 47 and 49 are of like diameter, and due to the reduction in diameter of the gear wheels 50, the pinions 60 on the drive shaft 43 aligned with the gear wheels 50 are not directly in mesh with each other, but are in mesh with the idler gears 62 which in turn are in mesh with the gear wheels 50 to cause the latter and their associated sprocket wheels 49 to rotate in a counter-clockwise direction, as indicated by the dotted arrow 65 in Fig. 1. Thus the sprocket chains 56 trained around the sprocket wheels 47 and 49 travel in opposite directions. Consequently I have provided at one side of the intermediate frame member 38, which may more particularly be referred to as the central longitudinal frame member, mechanism designed to effect the printing stroke of the bed or move the same towards the right from the position shown in Fig. 1, while the sprocket chains trained around the sprocket

wheels at the other side of the central longitudinal frame member 38 serve to return the printing bed from its extreme right-hand position to its left-hand position shown for the same in Fig. 1, which movement may be termed the idle or return stroke of the bed. It is to be noted that although the gear wheels 50 are smaller than the gear wheels 48 they are proportioned with respect to the pinions 60 on the drive shaft and the idler gears 62 meshing therewith that they travel in synchronism with the gear wheels 48 so that the bed-advancing mechanism releases the printing bed at the end of its printing stroke and at the same instant the bed-reversing mechanism becomes attached or harnessed to the bed and returns the latter to the beginning of its printing stroke, all under movements new and novel in the art.

To accomplish such actuation, the actuator brackets or yokes fastened to the underside of the printing bed are provided with downwardly opening slots 66 which permit the harnessing and unharnessing of the actuator rollers 57 from the bed and at the same time reduce the length required for the actuator brackets, and thus the pressure applied to the brackets by the actuator rollers is confined to a region above the horizontal plane in which the axes of the sprocket shafts 46 and 53 are located, and since one of said actuator brackets is longitudinally aligned with the space between the pair of sprocket chains trained around the sprocket wheels 47 and 54 and the other bracket is so aligned with the space between the pair of sprocket chains trained around the sprocket wheels 49 and 55, the actuator roller connecting each pair of sprocket chains is designed to enter the downwardly-opening slot in its cooperating actuator bracket or yoke and during the period of time the actuator roller forming part of the bed-advancing mechanism, which is that shown at the left in Fig. 4, enters its cooperating slot 66 and moves through an arc of 90° in the direction of the arrow 67 in Fig. 1, the movement of the printing bed is gradually accelerated until it reaches its maximum speed; it being understood that so long as the actuator roller is confined within the slot 66, the actuator bracket in which the actuator roller is trapped and the printing bed from which said bracket is suspended are moved under controlled operation. When the actuator roller reaches the crests of the sprocket wheels 54 associated therewith, the maximum speed of the actuator roller will have been reached and this maximum accelerated speed will be constant and is continued until the actuator roller reaches the crests at the tops of the sprocket wheels 47, after which the actuator roller travels through an arc of a circle of 90° under gradual deceleration or until it reaches a point in the horizontal plane of the axes of the non-rotatable shafts 46 and 53. The actuator roller then moves under gradually accelerated speed fully out of the slot 66 in said bracket and returns to its extreme left-hand position, as viewed in Fig. 1, first under gradual accelerated idle movement and thence under maximum and constant accelerated movement until it reaches a plane passing vertically through the axis of the non-rotatable shaft 53 and finally under decelerated movement completes its cycle of movement, one-half of which serves to move the printing press from left to right, as viewed in Fig. 1, and then idly returns to recommence the forward or printing movement of the printing bed, which is that in which the bed is moved from left to right.

As the printing bed reaches the end of its printing movement or stroke, the other actuator bracket will be in its extreme right-hand position so as to receive the actuator roller carried by the sprocket chains trained over the sprocket wheels 49 and 55, and similar cooperation takes place between said actuator roller and the actuator bracket aligned with the space between said last-mentioned sprocket wheels, whereby the printing bed is moved from its extreme right position to its extreme left position. It is, of course, understood that acceleration and deceleration in the movement of the printing bed takes place while said

actuator roller travels through arcs of circles of 90° above a plane passing horizontally through the axes of the two non-rotatable shafts 46 and 53 and during such arcuate movements the actuator roller moves upwardly into the slot 66 of the actuator bracket to gradually increase the speed of the printing bed at the beginning of its idle or return movement, and then after passing through a straight-lined course under constant and maximum speed said roller travels downwardly in the slot of said actuator bracket and finally becomes disengaged from the bracket so as to travel idly through its course of movement beneath a plane passing horizontally through the axes of the non-rotatable shafts 46 and 53. It will be apparent, therefore, that the mechanism rotatable on the non-rotatable shaft 46 at one side of the central longitudinal frame member 38 in association with the sprocket wheels 54 and sprocket chains 56 trained thereover are for the purpose of moving the printing bed through its printing motion, or from left to right, as viewed in Fig. 1, while the mechanism rotatable on the fixed shaft 46 at the other side of the central longitudinal frame member 38 in association with the sprocket wheels 55 and the sprocket chains 56 trained over the latter are for the purpose of moving the printing bed through its idle return or non-printing movement, whereunder the bed is moved from its extreme right position to its extreme left position, which is that shown in Fig. 1.

The two mechanisms arranged at opposite sides of the central longitudinal frame member 38 are exactly alike in construction with the exception that the pinions or gear wheels 59 on the drive shaft 43 are in direct mesh with the gear wheels 50 of the bed-advancing mechanism while the pinions or gear wheels 60 on the drive shaft are in mesh with intermediate idler gears or gear wheels 62 which in turn are in mesh with the gear wheels 50 of the bed-reversing mechanism so as to cause opposite movements of the sprocket chains forming part of bed-advancing and bed-reversing mechanisms. When the bed-advancing mechanism is causing the printing bed to begin its printing stroke, the actuator roller of said mechanism is on its dead center at the rearmost point of its carrying-chain or element and at that instant the actuator roller of the bed-reversing mechanism is also on its dead center at the rearmost point of its carrying chain.

It may here be mentioned that by restricting the length of the actuator brackets to the region above a plane passing horizontally through the axes of the sprocket shafts 46 and 53, permitted only by having the lower ends of the actuator brackets open for harnessing and unharnessing purposes, the leverage-like action created by the actuator rollers against the actuator hangers is reduced to the minimum and exists only during the decelerating and accelerating portions of the reciprocating movement of the printing bed. Such force, transferred to the printing bed of a press at a point below said plane would cause undesirable tilting of the printing bed, resulting in a bad impression or even causing blurring to take place.

For the purpose of restricting the height of the press while horizontally aligning the extreme positions of the actuating rollers with the axes of the non-rotatable shafts 46 and 53 and actuating the bed-advancing and reversing mechanisms within the smallest space possible, the non-rotatable shafts 46 and 53 have their upper portions notched in line with the path of travel of the actuator brackets, as at 68, and since such notching tends to weaken said shafts, the portions of the latter underneath the notches are reinforced by means of blocks 69 which have their upper faces concaved, as at 70, to receive the intact lower portions of the shafts and these blocks 69 are fastened to such intact shaft portions by means of bolts 71. The reinforced blocks are out of the paths of all of the movable parts of the mechanisms and render the notched portions of the shafts as rigid as all un-notched portions thereof. Said blocks also serve as spacers be-

tween sprocket wheels and hold the latter in properly spaced relation on their respective non-rotatable shafts.

Viewing Fig. 1 of the drawing, it will be seen that the actuator roller 57, as shown therein, is positioned in the plane passing horizontally through the axes of the shafts 46 and 53, which position has heretofore been referred to as a neutral point or line, but which more particularly may be considered the dead center for said roller, or the beginning of the printing stroke, but as the chains carrying said roller are moved clockwise, the upper stretch thereof is moved in the direction of the arrow 72, while the lower stretch travels in a reverse direction and during this action the actuator roller will rise within the slot 66 in the actuator bracket to a point at or near its upper end as it reaches a plane passing vertically and transversely through the notch 63, thereby carrying the actuator bracket forwardly with the roller. Consequently the bracket, whose lower end is at all times above the bottom of the notch 63 will pass freely through the latter.

As clearly shown in Figs. 7, 8 and 9, the actuator roller comprises a non-rotatable cylindrical core or body portion 73 around which a sleeve 74 is rotatably mounted, the actuator roller being carried by two pins 75, 76 which pass through the cylindrical core and through overlapping ends of three links of each sprocket chain; said pins serving to connect the links of each pair of said sprocket chains and also support the rollers between said chains. If desired the ends of the pins may have sleeves 77 surrounding the same where they pass through the links of the chains and these may be rotatably mounted on said pins.

The non-rotatable shafts 46 and 53 extend outwardly beyond the intermediate frame members 37 and 39 and passing through the projecting ends of said shafts are chain-adjusting rods 78 which lie in contact with the outer sides of said frame members. Set screws 79 are threaded axially into said shafts and impinge with their inner ends against said rods. The ends of said set screws extend from the ends of said shaft to permit of the ready application of a suitable tool thereto to loosen or tighten the same. The forward end of each rod is curved outwardly, as at 80, to serve as a handle or a fingerhold and the frame members 37, 38 and 39 are slotted, as at 81; the non-rotatable shaft 53 being adjustable in the slots 81 so provided for the purpose of adjusting the distance between the axes of the shafts 46 and 53 and thereby tighten or loosen the sprocket chains 56 as may be required; it being simply necessary to loosen the set screws 79 in the ends of the shaft 53 and pull the latter rearwardly by grasping the outwardly curved ends 80 of said rods and pulling the shaft 53 toward said ends. Thus the shaft 53 may be slid along the slots 81, after which the set screws 79 in the shaft 53 may again be tightened to hold all parts in adjusted position.

The extensions 34 of the side members 33 receive trunnions 83 at opposite ends of an impression cylinder 84, which is of the usual formation. One end of the impression cylinder is provided with a boss 85, which extends inwardly from its rim, as best shown in Figs. 12 and 16, in which boss a driving pin 86 is fastened and which pin enters a slot 87 formed radially in a gear wheel 88 covering the end of said impression cylinder and provided with a peripherally grooved axially-disposed boss 89 and an axial opening 90 through which the trunnion 83 at the adjacent end of the impression cylinder is loosely passed so that the gear wheel may be moved with respect to the impression cylinder, or more particularly so that the axes of the two may be altered relatively and assume eccentric relationship at a predetermined point in the movement of the printing bed.

Secured to the edge of the printing bed at the corresponding side is a gear rack 91 with which the gear wheel 88 is adapted to mesh. Said gear wheel may be termed the cylinder gear or cylinder driving gear inasmuch as it serves to rotate the cylinder. By reason of the pin-and-slot connection provided between the im-

pression cylinder and the gear wheel 88 and due to the fact that the gear wheel is held in mesh with the gear rack 91, relative change in the axial disposition of the cylinder and said gear wheel is confined to radial movement of the gear wheel, limited by the radial slot 87 and the pin 86 extending into or through said slot. The impression cylinder is therefore driven by means of the driving pin 86 projecting outwardly from one end of the cylinder and entering the slot 87 in the cylinder driving gear 88 so that when the printing bed approaches the ends of its strokes said cylinder driving gear is raised and lowered for timed engagement with the gear racks 91 and 93, successively.

When the printing bed is in a position to commence the printing stroke or movement, the cylinder gear wheel 88 is in mesh with the gear rack 91 and therefore upon movement of the printing bed 42, the impression cylinder is rotated in the direction of the arrow 92 shown in Figs. 1 and 11. This is due to its pin and slot connection with said cylinder gear and the meshing coaction of the latter with the gear rack 91. It is, however, the purpose of this invention to disengage the gear wheel from said gear rack during the idle return or non-printing stroke of the printing bed and this is accomplished by mechanism controlled by the drive shaft 43 and interposed between the latter and the cylinder gear 88, which mechanism may be referred to as trip mechanism adapted to disengage said cylinder gear 88 from the gear rack 91 and engage it with a second gear rack 93 disposed above, parallel with and in spaced relation to the gear rack 91.

The gear rack 93 is pivotally attached at one end to a bracket 94 rising from the end of the gear rack 91 normally adjacent the impression cylinder and it is telescopically arranged within a sleeve 95, also disposed parallel with the gear rack 91 and supported at the end distant from the end of bracket 94 by a post 96 rising from the frame of the press. Said sleeve is therefore held against longitudinal movement with the gear rack 93 or at least a portion thereof telescopically confined therein at all times. The end of the gear rack 93 distant from its pivotal connection with the bracket 94 is provided with a roller 97 whose diameter is slightly less than the integral diameter of the sleeve 95 so that it may ride in guiding contact with the inner surface of the wall of said sleeve along the bottom region thereof, as best shown in Fig. 10.

The sleeve 95 has the lower portion of its cylindrical wall cut away to form an elongated opening 98 therein and render the teeth of the gear rack 93 which happens to be positioned above said opening, accessible for meshing engagement with the teeth of said cylinder gear. The teeth of the gear rack 93 are therefore capable of inter-meshing with the teeth of the cylinder gear 88 when such action is required, as will appear hereinafter.

In order to fixedly support the sleeve 95 above the cylinder gear 88, a bracket 99 is secured to the upper end of the upward extension 34 of the side frame member 33 at the same side of the press. Said bracket is secured in any suitable manner to said sleeve and has a guide roller 100 secured thereto which has its marginal portion extending through an opening 101 in the sleeve 95 directly above the elongated opening 98 and bearing against the upper edge of the gear rack 93.

It will thus be understood that my improved press is provided with means for reciprocating the printing bed under straight-lined guided motion and that under such reciprocating action the forward motion of the bed may be referred to as the printing stroke while the return motion thereof may be considered the idle stroke of the bed during which the printed sheets are removed from the press in a manner commonly known in the art. It will also be understood that during the forward or printing stroke of the bed the cylinder gear or gear wheel 88 will be in meshed relation with the gear rack

91 and out of mesh with the gear rack 93 and that this relationship between such parts is maintained until the bed reaches the end of its printing stroke, whereupon the gear shifting mechanism hereinbefore referred to in a general way is designed to momentarily move or shift the cylinder gear or gear wheel 88 out of mesh from the gear rack 91 without causing said cylinder gear or gear wheel to mesh with the gear rack 93. During this momentary disengagement of the cylinder gear from the rack 91, the bed is being moved in a direction opposite that of the rotation of the impression cylinder and while or before the bed is being so moved the cylinder gear 88 is being shifted into engagement with the gear rack 93 and the impression cylinder continued in the direction of rotation given it during the printing stroke without in any manner interfering with the removal of the printed sheet.

This gear-shifting mechanism comprises a cam 102 secured to a jack shaft 103; the cam being provided with a cam groove or raceway 104 in which a roller 105 is disposed to travel, the roller being rotatably mounted on a pin 106 secured in a shifter member or bar 107 extending upwardly from the jack shaft 103 and having its lower end slotted, as at 108, to allow the jack shaft to be passed therethrough and to enable the shifter member or bar 107 to be moved upwardly and downwardly in a guided manner due to the slot 108 fitting shaft 103 and acting as a guide for the member or bar 107. A spacing nipple 109 is interposed between said shifter member or bar and the adjacent side frame member 33 to assure retention of the roller 105 within the cam groove or raceway 104. The upper end of the shifter member or bar is entered in the peripheral groove of the axially-disposed boss 89 formed on the cylinder gear wheel 88.

The trunnions 83 at opposite ends of the impression cylinder may be alike in formation and diameter, but the trunnion at the end of the cylinder adjacent the shifter member or bar 107 is passed through the axial opening 90 in the cylinder gear and its axially disposed boss 89; said opening being of a diameter to provide a circular clearance space 110 for free movement of said trunnion within said axial opening and for free radial movement of said cylinder gear with respect to the impression cylinder so that the gear wheel is permitted to move for the purpose of altering the axial relationship between the impression cylinder and said cylinder gear.

The printing bed is provided with the usual bearer strips 111 at its longitudinal marginal portion over and in contact with which the impression cylinder travels, said cylinder being slightly enlarged in diameter at opposite ends to provide bearer regions 112 corresponding in width with that of the bearer strips 111. Said bearer regions travel in contact with said bearer strips during the printing stroke of the bed but are moved out of contact therewith at or near the end of the printing stroke and consequently out of contact with the type form or other printing medium held on the bed; such relative position of parts being maintained during the return or idle movement of the printing bed.

The jack shaft 103 is journaled in the side frame member 33 adjacent the cam 102 and in a bracket 113 fastened to the intermediate frame member 39, outside of which the drive shaft 43 terminates, the gear teeth or pinion 45 of which are in mesh with a gear wheel 114 secured to said jack shaft adjacent the bracket 113. The manner of securing the gear wheel 114 and the cam 102 is best illustrated in Fig. 12, set screws 115 being provided for that purpose. It may here be stated that similar or any other suitable means for securing other operating parts of the press to shafts may be provided and since the manner of fastening gear wheels, sprocket wheels and the like to shafts is merely a mechanical expedient, ref-

erence made to securing such parts to shafts should suffice.

While the trunnion 83 at the gear end of the impression cylinder is described as passing loosely through the axial opening in the cylinder gear or gear wheel 88, the outer end thereof and the outer end of the trunnion at the opposite end of said cylinder are preferably reduced in diameter and rotatably journaled in bearings 116 passed through openings 117 in the side frame members 33, each of said bearings having a cylindrical portion 118 from which extends spaced-apart lugs 119 which project from diametrical opposite sides of said cylindrical portion so that they are paired at each side of the vertical center of said bearing and straddle the side member of the frame. One pair of lugs of each bearing has a pivot pin 120 passed therethrough and through the side frame member straddled thereby while the other pair of lugs has a pin 121 passed therethrough and bridging the spaces between the lugs. This pin 121 is passed through a clearance slot 122 formed in the side frame member straddled by said lugs, and secured to one end of said pin is a shifter rod 123 which extends downwardly and is adapted to be reciprocated in the manner in which the shifter member or bar 107 is reciprocated, either by means of a device similar to the cam operating device which includes the cam 102, or by any other suitable means commonly employed for imparting reciprocating motion to a rod or bar. Inasmuch as the shifter device or mechanism forms no part of my invention, it will, of course, be understood that any shifter device suitable for the purpose of reciprocating the shifter rod 123 or the shifter member or bar 107 which will cause a complete cycle of movement of such rod, member or bar during each cycle of movement of the printing bed, and that the mechanisms, including the means for reciprocating the printing bed as well as rotating the impression cylinder are sized and proportioned relatively to accomplish such action.

It will be apparent from the foregoing that I have provided means in a reciprocating flat bed printing machine to cause reciprocation of the printing bed and for utilizing the movement of said printing bed to actuate the impression cylinder; also to cause the latter to be rotated in one direction during both the printing and idle strokes of the printing bed, with a momentary disconnection of the printing bed from the printing cylinder. Therefore when the printing bed is at what may be considered its point of rest or at the beginning of its printing stroke—which may also be considered its normal position—the cylinder gear or gear wheel 88 is in mesh with the gear rack 91 and during the forward or printing stroke of the bed the impression cylinder is rotated in synchronism with the printing bed and said gear wheel until the printing bed reaches the end of its printing stroke. During this printing stroke the shifter rod 123 and the shifter member or bar 107 are in the positions shown in Fig. 11, at which time the cylinder gear or gear wheel 88 is in mesh with the gear rack 91. As the printing bed closely approaches or reaches the extreme end of its printing stroke, the shifter mechanism employed for actuating the shifter rod 123 will cause the bearings 116 in which the end trunnions 83 of the impression cylinder are journaled to swing said bearings on their pivot pins 120, whereupon the pins 121 move upward in the slots 122. The trunnions 83 of the impression cylinder are therefore slightly elevated which is permitted by reason of the enlarged axial opening 90 in the cylinder gear or gear wheel 88 through which the enlarged portion of one of said trunnions is passed; also by reason of the openings 117 in the side frame members being of larger diameter than the bearings 116, which openings provide clearance spaces for movement of the bearings in their respective side frame members 33 in which they are movably retained. Under this action the impression cylinder is raised slightly to clear the type or printing medium on the printing bed.

The relationship of the shifter device or mechanism whereby the shifter rod 123 is actuated to the shifter device or mechanism which includes the cam 102 is such that the latter immediately comes into action, with the result that the shifter member or bar 107 is raised and since this shifter bar has its upper end encircling the axially-disposed boss 89 of the cylinder gear or gear wheel 88, the latter is raised to disengage it from the gear rack 91, which action is independent of the action of the impression cylinder and is permitted by the pin-and-slot connection between the latter and said cylinder gear or gear wheel.

This raising or lifting of the cylinder gear or gear wheel 88, in addition to disengaging it from the gear rack 91 causes engagement of its teeth with the teeth of the gear rack 93 and as this gear rack is moved outwardly and inwardly within the sleeve 95 during the complete cycle of movement of the printing bed and the said sleeve has a fixed position while the gear rack 93 travels with the printing bed, actuation of the cylinder gear or gear wheel 88 is maintained with the gear rack 93 during the entire return or idle movement of the printing press, thereby assuring movement of the impression cylinder in one and the same direction during the complete cycle of movement of the printing press, excepting only an instant required to disengage the cylinder gear or gear wheel 88 from the gear rack 91 and engage the same with the gear rack 93.

For the purpose of maintaining a straight-line movement for the shifter member or bar 107, the upper end thereof which encircles the grooved axially-disposed boss 89 is extended in opposite directions to provide lateral wings 125 which are vertically slotted, as at 126 and into which guide pins 127 extend; said pins projecting inwardly in the said slots 126 from bosses 128 on the adjacent side frame member 33 which bear against the lateral wings 125 and through the medium of the groove formed in the axially-disposed boss 89 serve to hold the gear wheel 88 in proper relation to the impression cylinder.

From the foregoing it will be apparent that my invention embodies the basic idea of utilizing endless chains or similar elements traveling over horizontal axes transversely disposed, spaced-apart and having actuator elements attached to said chains for engagement with actuator brackets, or what may be termed saddles, attached to depend from a printing bed and actuated by said chains under reciprocating movement commencing at the beginning of its printing stroke under gradually accelerated speed which is maintained at its maximum through the intermediate portion of its printing stroke and terminates under gradually decelerated movement until it reaches the end of its printing stroke, at which point it is reversed from its fully decelerated speed under gradually accelerated movement until it reaches its maximum return or idle movement, thence under maximum movement through the intermediate portion of its return or idle stroke and finally at the end of its return or idle movement under gradually decelerated movement until it returns to the extreme end of its idle or return movement, which is at the point of beginning of its printing stroke, or what I term normal position. Such reciprocating movement is transferred under synchronized action to the impression cylinder by means whereby said type form is caused to contact the paper or other medium to be printed upon and whereby when said printing stroke is completed and the return movement of the printing bed commenced, said impression cylinder being raised from the printing bed, after which and instantly thereafter being disconnected from the printing bed and operatively engaged with means to rotate the impression cylinder in the same direction in which it was actuated by the printing bed during its printing stroke.

In the modification shown in Figs. 22, 23, 24 and 25 all the advantages of the preferred construction are retained, but in place of the gear rack 90 having teeth along

its upper edge only, I employ a gear rack bar 129 which is provided with a straight-lined row of teeth along its upper edge forming a gear rack 130 and a straight-lined row of teeth along its lower edge forming a gear rack 131. In this modification, the cylinder gear or gear wheel 88 attached to one end of the impression cylinder is adapted for meshing engagement with the gear rack 130, while arranged in constant mesh with the gear rack 131 is a gear wheel 132 which is secured to a jack shaft 133 in any approved manner journaled in the intermediate frame member 40 and the adjacent side frame member 33. Secured to said jack shaft 133 outside of said side frame member is a gear wheel 134 which is of the same diameter as gear wheel 132 and is in mesh with an idler gear wheel 135 rotatable on a stub shaft 136 fastened in said frame member. The idler gear wheel 135 is in turn in mesh with a second idler gear wheel 137 rotatable on a stub shaft 138 which is non-rotatably held in the side frame member 33 in any suitable manner. The idler gear wheel 137 is in mesh with a gear wheel 139 secured to a shaft 140 journaled in the upper end of the upward extension 34 of the side frame member 33; said shaft 140 having a gear wheel 141 fastened to its inner end which is of the same diameter as the gear wheel 139 and is adapted for meshing engagement with the cylinder gear or gear wheel 88 associated with the adjacent end of the impression cylinder 84, which cylinder is of the usual construction provided with paper-gripping means associated with means for discharging the printed sheet from the cylinder.

The means employed for disengaging the cylinder gear or gear wheel 88 from the gear rack 130, which may be considered the upper gear rack, may be the same means employed in the preferred construction. However, it is to be noted that the train of gears comprising the gear wheels 132, 134, 135 and 137 have their axes in the same vertical plane as the axes of the impression cylinder 84 and the cam 102 hereinbefore described. Consequently the shifter member or bar 107 has a curved portion 107^a between its ends which detours the jack shaft 133 with clearance space between the two so that the shifter member or bar may move in the same manner as described for the shifter member or bar 107 in the preferred construction.

In this modification, the cylinder gear or gear wheel 88 at the end of the impression cylinder is normally in mesh with the upper gear rack 130 and retains its meshing engagement therewith until the printing bed reaches the end of its printing stroke and during such times the said cylinder gear or gear wheel is out of mesh with the gear wheel 141, which continues to rotate idly during the printing stroke. After the bearings 116 at opposite ends of the impression cylinder are swung on their pivots or pivot pins 120 in the manner specified with reference to the preferred construction, the impression cylinder is raised sufficiently to move out of contact with the printing form and immediately thereafter the shifter member or bar 107^a is brought into action by the cam 102 causing the cylinder gear or gear wheel 88 to become disengaged from the upper rack 130 and engage the gear wheel 141 which is driven from the lower gear rack 131 through the medium of the gear wheel 132 disposed inside of the side frame member 33 and the train of gears disposed in a plane outside of said side frame member. Thus the impression cylinder is caused to rotate during the return stroke of the printing bed in the same direction in which it was rotated during the printing stroke of said bed.

It will be apparent therefore that in the modification the gear rack 130, which may be termed the upwardly-facing gear rack, is the equivalent of and serves the same purpose as the gear rack 91 in the preferred construction and that the gear rack 131, which may be termed the downwardly-facing gear rack in the modification shown and described, serves the same purpose as the gear rack 93 in the preferred construction. Under both

constructions the printing bed is reciprocated under various speeds during both its printing stroke and its return or idle stroke and that the reciprocating movement of the bed is transferred to rotary movement for the impression cylinder, which rotary movement is maintained in one direction during both the printing stroke and the return or idle stroke of the bed and that the impression cylinder is therefore synchronized to the movement of the bed.

It is to be understood that in order to synchronize the movement of the impression cylinder with the printing bed the cylinder gear or gear wheel 88 and the gear wheels 132 and 134 are of like diameters; that the idler gear wheels 135 and 137 are or can be of like diameters but are not necessarily so, and that the gear wheel 139 and the gear wheel 141, which latter may be termed a driving pinion, are of like diameters.

It will also be apparent that the printing form may be lengthened and when set up in or on the printing bed may be set up toward the rear, with assurance that its length will be as great as that possible to use on other reciprocating flat bed printing presses while allowing the addition of one or more additional inking rollers, inasmuch as the impression cylinder is driven at all times by the bed; and further, that the end portions of the complete printing stroke, under gradual acceleration at the beginning of the stroke and under gradual deceleration at the end of the printing stroke, enables the printing cylinder to conform to the varied speeds imparted to the printing bed with the actuating mechanism provided for reciprocating the latter.

In Fig. 6 I have shown inking rollers 142 in dotted lines and while there is nothing new or novel in the location of the inking rollers with respect to the printing bed, an additional ink roller may be employed in rear of those illustrated in dotted lines in said figure, which additional inking roller provides for better ink distribution.

Where, in the specification and claims, the term "type form" is used, it is intended to mean a form set up of individual type or any other medium by means of which printing can be effected on a sheet of paper or the like by means of pressure applied by an impression cylinder, or other impression element falling within the scope of the following claims.

Having thus described my invention what I claim is:

1. In a printing press, an elongated frame, spaced apart shafts disposed transversely in said frame, sprocket wheels mounted on said shafts, means to rotate the sprocket wheel on one of said shafts, a sprocket chain trained over said sprocket wheels, a printing bed reciprocal along said elongated frame, actuating connection between said sprocket chain and said printing bed comprising a vertically-slotted bracket depending from said printing bed and an actuator carried by said chain and adapted to be harnessed to and unharnessed from said bracket and whereby said printing bed is moved through its printing stroke in one direction at gradually accelerated speed during the first portion of its printing stroke, at constant maximum speed during the intermediate portion of its printing stroke and under gradually decelerated speed during the end of its printing stroke, means to cause said printing bed to move in an opposite direction when said actuator is unharnessed from said slot said actuator being movable in a generally vertical direction within said slot only between said printing bed and a plane passing horizontally through the axes of said sprocket wheels, said printing bed having gear means secured thereto and movable therewith, an impression cylinder mounted in said frame above said printing bed, and coacting gear means carried by said impression cylinder for meshing connection with said first-mentioned gear means to cause the impression cylinder to rotate in one direction only in synchronism with the reciprocating movement of said printing bed.

2. In a printing press, an elongated frame, spaced-

apart non-rotatable shafts secured transversely to said frame, sprocket wheels rotatable on said shafts, a gear wheel rigid with the sprocket wheel on one of said shafts, a drive shaft parallel with said last-mentioned shaft, a pinion on said drive shaft meshing with said gear wheel, a sprocket chain trained around said sprocket wheels, a printing bed mounted for reciprocal movement along said frame and having a depending actuator bracket with a vertical slot opening at the lower end of said bracket, an actuator roller carried by said sprocket chain and adapted to enter said slot for moving said bracket and the printing bed to which it is attached in a forward direction to effect a printing stroke, first under gradually accelerated movement, thence under constant maximum speed and finally under gradually decelerated movement to complete the printing stroke, said actuator roller entering the slot of said bracket at its open lower end at the beginning of said printing stroke, means to return said printing bed to the beginning of its printing stroke, an impression cylinder rotatable in said frame, and means interposed between said printing bed and said impression cylinder to cause the latter to rotate under varying speeds in synchronism with the movement of said printing bed.

3. In a printing press, an elongated frame, spaced-apart non-rotatable shafts secured transversely in said frame, sprocket wheels rotatable on each of said shafts and transversely spaced-apart, gear wheels rotatable with the sprocket wheels on one of said shafts, means for rotating the gear wheels and the sprocket wheels rotatable therewith, the sprocket wheels on one of said shafts being longitudinally aligned and paired with the sprocket wheels on the other shaft, a sprocket chain trained around each pair of said sprocket wheels, an actuator interposed between said sprocket chains and bridging the space between the two, a printing bed reciprocal along said frame, an actuator bracket secured to the underside of said printing bed and having a slot therein open at the lower end of said bracket, said bracket being positioned to travel under reciprocating movement of said bed through the space between said sprocket chains and adapted to have said actuator enter the slot of said actuator bracket to cause movement of the latter and said printing bed, said actuator moving upwardly into said slot to effect a gradually accelerated movement of the printing bed at the beginning of its printing stroke, to cause said printing bed to be moved under maximum and constant speed during the intermediate portion of its printing stroke and to finally complete its printing stroke under gradually decelerated movement, said actuator entering the open lower end of the slot in said bracket at the beginning of the printing stroke and leaving said slot at the end of said stroke, means to return said printing bed to the beginning of its printing stroke, an impression cylinder carried by said frame, and means to cause said impression cylinder to rotate under varying speeds in synchronism with the varying speeds of said printing bed in traveling through its printing stroke.

4. In a printing press, two endless traveling elements disposed in a given direction and trained over rotatable elements having spaced-apart transverse axes disposed at a right angle to said given direction and means for causing said endless traveling elements to travel in opposite directions, said endless traveling elements being transversely spaced-apart, a printing bed reciprocal along a plane parallel with the plane in which the axes of said rotatable elements are disposed, depending transversely spaced-apart actuator elements carried by said printing bed and having vertical slots therein open at their lower ends, coacting actuator elements carried by said endless traveling elements, the coacting actuator element carried by one of said endless traveling elements being adapted to enter the lower open end of the slot in one of said first-mentioned depending actuator elements when said printing bed is in normal position and to rise within said

15

slot and cause said printing bed to pass through the initial portion of its printing stroke under gradually accelerated speed, said last-mentioned coacting actuator element moving said printing bed through the intermediate portion of its printing stroke under constant accelerated speed while traveling in a straight-lined direction and at the end of said printing stroke gradually moving out of said slot under gradually decelerated speed to continue its travel idly to the beginning of the printing stroke, the other of said coacting actuator elements entering the lower open end of the slot in the other depending actuator element at the end of the printing stroke of said printing bed and causing the latter under reverse movement of the other endless traveling element to return said printing bed to its normal position, said actuator elements being under effective co-action only between said printing bed and a plane parallel therewith passing through the axes of said rotatable elements, an impression cylinder rotatably mounted in said frame, and means interposed between said impression cylinder and said printing bed actuated by the latter to cause said impression cylinder to be rotated in synchronism with the movement of said printing bed.

5. In a printing press, a frame, a printing bed reciprocally mounted on said frame, bed-advancing mechanism and bed-reversing mechanism carried by said frame, each of said mechanisms including an endless traveling element traveling along a path which includes semi-circular end portions and straight-lined intermediate portions parallel with the movement of said printing bed and actuator means between each of said endless traveling elements and said printing bed whereby said bed is caused to move in a forward direction to effect the printing stroke for the bed under varying speeds and to effect the idle return stroke of the printing bed also under varying speeds, the actuator means of one of said mechanisms alternating with the actuator means of the other of said mechanisms to cause reciprocating movement of said bed.

6. In a printing press, a frame, a printing bed reciprocally mounted in said frame to effect a forwardly-moving printing stroke and an idle rearwardly-moving return stroke, said printing bed carrying a type-form, means for reciprocating said printing bed, a gear rack carried by said printing bed, an impression cylinder mounted in said frame for rotatable movement in a given direction, a gear wheel carried by said printing cylinder at one end thereof and normally in mesh with said gear rack, means at opposite ends of said printing cylinder for raising the latter out of contact with said type-form as the printing bed reaches the end of its printing stroke so as to disengage said gear wheel from said gear rack, a second gear rack parallel and movable with said first-mentioned gear rack and in vertical alinement therewith, and means for lifting said gear wheel to mesh the same with said second gear rack as the printing bed starts its return movement.

7. In a printing press, a frame, a printing bed reciprocally mounted in said frame to effect a forwardly-moving printing stroke and a rearwardly-moving return stroke, said printing bed carrying a type-form, means for reciprocating said printing bed, a gear rack carried by said printing bed, an impression cylinder mounted in said frame for rotatable movement in a given direction, a gear wheel carried by said impression cylinder at one end thereof and having its axis normally coincident with the axis of said printing cylinder, said gear wheel being in mesh with said gear rack during the printing stroke of said printing bed, means at opposite ends of said impression cylinder for raising the latter to disengage said gear wheel from said gear rack when said printing bed reaches the end of its printing stroke, a gear element normally spaced from said gear wheel during the printing stroke of said printing bed, means interposed between said printing bed and said gear element for causing the latter

16

to be idly actuated during the printing stroke of said printing bed, a means to cause said gear wheel to be lifted with respect to said impression cylinder into engagement with said gear element as said printing bed starts its return movement, said gear element causing said impression cylinder to continue rotation in said given direction.

8. In a printing press, an elongated frame, a printing bed reciprocal along said frame, a gear rack secured to one side of said printing bed, an impression cylinder rotatable in said frame, a gear wheel at one end of said impression cylinder normally concentric therewith, a sleeve in a plane above and parallel with said gear rack having one end secured to said frame and its other end terminating above said gear wheel, a bracket extending upwardly from said gear rack, a second gear rack pivotally secured to the upper end of said bracket and normally telescoped into said sleeve, said sleeve having an opening therein above said gear rack, means at opposite ends of said impression cylinder to raise the latter into non-printing relation to said type-form and to disengage said gear wheel from said first-mentioned gear rack as the printing bed reaches the end of its printing stroke, and means to position said gear wheel eccentrically with respect to said impression cylinder and thereby cause said gear wheel to mesh with said second gear rack through the opening in said sleeve so as to continue the rotation idly of said impression cylinder in said given direction during the return stroke of said printing bed.

9. In a printing press, an elongated frame, a printing bed reciprocal along said frame, means to reciprocate said printing bed, an upwardly-facing gear rack and a downwardly-facing gear rack carried by said bed at one side thereof, an impression cylinder rotatable in said frame in a given direction, a cylinder gear wheel at one end of said impression cylinder normally concentric therewith and in engagement with said upwardly-facing gear rack, a second gear wheel in mesh with said downwardly-facing gear rack corresponding in diameter to that of said first-mentioned gear wheel, a third gear wheel coaxial with said second gear wheel and of like diameter therewith, intermeshed idler gear wheels, one of which is maintained in mesh with said third gear wheel, a pinion with which the other of said idler gear wheels is in mesh, a shaft to which said pinion is secured, a cylinder-driving pinion coaxial with said first-mentioned pinion and of like diameter therewith, said cylinder-driving pinion being disposed in line with said cylinder gear wheel and normally out of mesh therewith, means to disengage said cylinder gear wheel from said upwardly-facing gear rack as the printing bed reaches the end of its printing stroke and to momentarily maintain said cylinder gear wheel out of contact with said cylinder-driving pinion, and means to position said cylinder gear wheel eccentrically with respect to said impression cylinder during the beginning of the return stroke of said printing bed and thereby cause said cylinder gear wheel to engage said cylinder-driving pinion and continue the rotation of said impression cylinder in said given direction.

10. In a printing press, a frame having side members and intermediate longitudinal frame members parallel with said side members, spaced-apart transversely-disposed non-rotatable shafts held within intermediate frame members and having their ends projecting outwardly from two of said frame members, a sprocket wheel rotatable on each of said shafts and alined with each other, a sprocket chain trained over said sprocket wheels, the intermediate frame members in which said shafts are held having elongated slots in which one of said non-rotatable shafts is adjustably held and circular openings through which the other of said shafts is passed and corresponding in diameter therewith, adjusting rods passed diametrically through the projecting ends of said shafts and bearing against the outer sides of the frame members from which the ends of said shafts project, set screws

threaded axially into opposite ends of said shafts and impinging against said adjusting rods, the shaft passing through said elongated slots being movable toward and from the other of said shafts upon loosening the set screws threaded thereinto so as to loosen or tighten said sprocket chain, said last-mentioned set screws when tightened holding said shafts in adjusted position.

11. In a printing press, a frame, a printing bed carried by said frame, oppositely traveling endless elements beneath said printing bed, actuator means carried by said endless elements to alternately engage said printing bed to reciprocate the same and effect a printing stroke and an idle return stroke, said actuator means assuming a neutral position with respect to said endless elements at the end of each stroke so as to start the printing stroke at the instant the idle return stroke is completed and to start the idle return stroke at the instant the printing stroke is completed, and an impression roller carried by said frame and rotated in synchronism with the movement of said printing bed.

12. In a two-revolution printing press, an elongated frame, a printing bed slidable on said frame and having a printing medium thereon, endless traveling elements each provided with an actuator transversely disposed

thereon, said printing bed having actuator hangers depending therefrom adapted to be engaged alternately by the actuators of said oppositely traveling endless elements, said actuator hangers having vertical slots therein open at their lower ends to alternately receive the actuators transversely arranged on said actuator elements and so disposed that said actuators reach dead centers at opposite ends of said actuator elements simultaneously, with one actuator entering the slot of one actuator hanger while the other actuator is leaving the slot of the other actuator hanger, and an impression roller traveling in contact with said printing medium and actuated under reciprocating movement of said printing bed.

References Cited in the file of this patent

UNITED STATES PATENTS

407,652	Fenner -----	July 23, 1889
457,286	Maxson et al. -----	Aug. 4, 1891
740,533	Cleathero -----	Oct. 6, 1903
1,180,593	Leilich -----	Apr. 25, 1916
1,200,956	Leilich -----	Oct. 10, 1916
2,105,261	Pohler -----	Jan. 11, 1938
2,371,693	Kelly -----	Mar. 20, 1945