



US00D720205S

(12) **United States Design Patent**
Reynard et al.

(10) **Patent No.:** **US D720,205 S**

(45) **Date of Patent:** **** Dec. 30, 2014**

- (54) **SEMI-AUTOMATED INTERCONNECTOR**
- (71) Applicant: **Duraloc Limited**, North Yorkshire (GB)
- (72) Inventors: **Kenneth Reynard**, North Yorkshire (GB); **Stephen Reynard**, North Yorkshire (GB)
- (73) Assignee: **Duraloc Limited**, New Yorkshire (GB)
- (**) Term: **14 Years**
- (21) Appl. No.: **29/443,415**
- (22) Filed: **Jan. 17, 2013**

5,791,808 A	8/1998	Nyholm	
D399,008 S *	9/1998	Thomas	D24/232
D465,407 S *	11/2002	Reynard	D8/382
D680,416 S *	4/2013	Dalton	D8/343
2003/0006233 A1	1/2003	Reynard	

- (30) **Foreign Application Priority Data**
- Nov. 14, 2012 (GB) PCT/GB2012/052821
- (51) **LOC (10) Cl.** **08-07**
- (52) **U.S. Cl.**
- USPC **D8/343**; D8/382
- (58) **Field of Classification Search**
- USPC D8/330, 331, 343, 344, 349, 382;
70/431, 466; 292/2, 209, 346; 411/511,
411/337; 24/287; 403/315, 316
- See application file for complete search history.

FOREIGN PATENT DOCUMENTS

DE	3538892	5/1986
DE	9317501	2/1994
DE	19835405	2/2000
DE	19937860	2/2001
EP	2147874	1/2010
FR	2046048	3/1971
GB	1356236	6/1974
GB	2390360	1/2004
JP	11-39390	5/1989
JP	2001-171785	6/2001
JP	2003-182683	7/2003
JP	2004-018026	1/2004
JP	2006-076636	3/2006
WO	WO 96/00180	1/1996
WO	WO 99/64326	12/1999

* cited by examiner

Primary Examiner — Prabhakar Deshmukh
(74) *Attorney, Agent, or Firm* — Sheridan Ross P.C.

(57) **CLAIM**
The ornamental design for a semi-automated interconnector, as shown and described.

(56) **References Cited**

U.S. PATENT DOCUMENTS

3,052,941 A	9/1962	Abolins et al.	
3,261,070 A	7/1966	Abolins	
3,578,374 A *	5/1971	Glassmeyer	294/68.1
3,726,550 A	4/1973	Johnson et al.	
3,752,511 A *	8/1973	Racy	24/287
4,026,596 A *	5/1977	Carr	410/82
4,082,052 A *	4/1978	Looks	410/82
4,196,673 A *	4/1980	Looks	410/89
4,626,155 A	12/1986	Hlinsky et al.	
4,782,561 A *	11/1988	Hayama	24/287
5,012,560 A *	5/1991	Janke et al.	24/287
5,062,752 A *	11/1991	Takaguchi	411/347
5,193,253 A *	3/1993	Janke et al.	24/287

DESCRIPTION

FIG. 1 is a perspective view of a semi-automated interconnector showing the our design;
FIG. 2 is a front elevation view thereof;
FIG. 3 is a rear elevation view thereof;
FIG. 4 is a right elevation view thereof;
FIG. 5 is a left elevation view thereof;
FIG. 6 is a top plan view thereof; and,
FIG. 7 is a bottom plan view thereof.
The broken lines environment is for illustrative purpose only and forms no part of the claimed design.

1 Claim, 4 Drawing Sheets

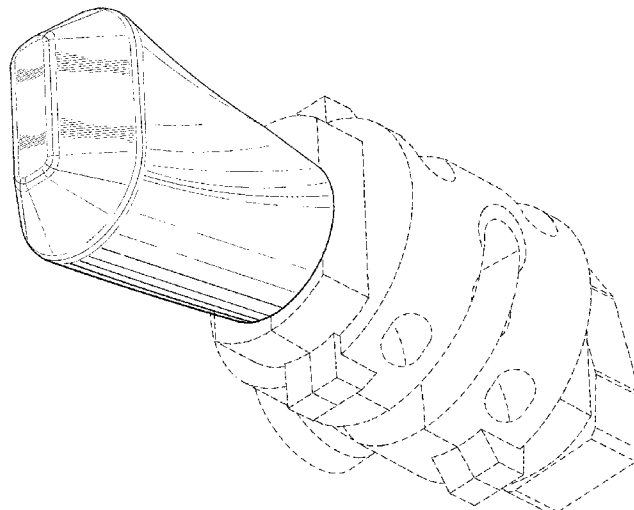

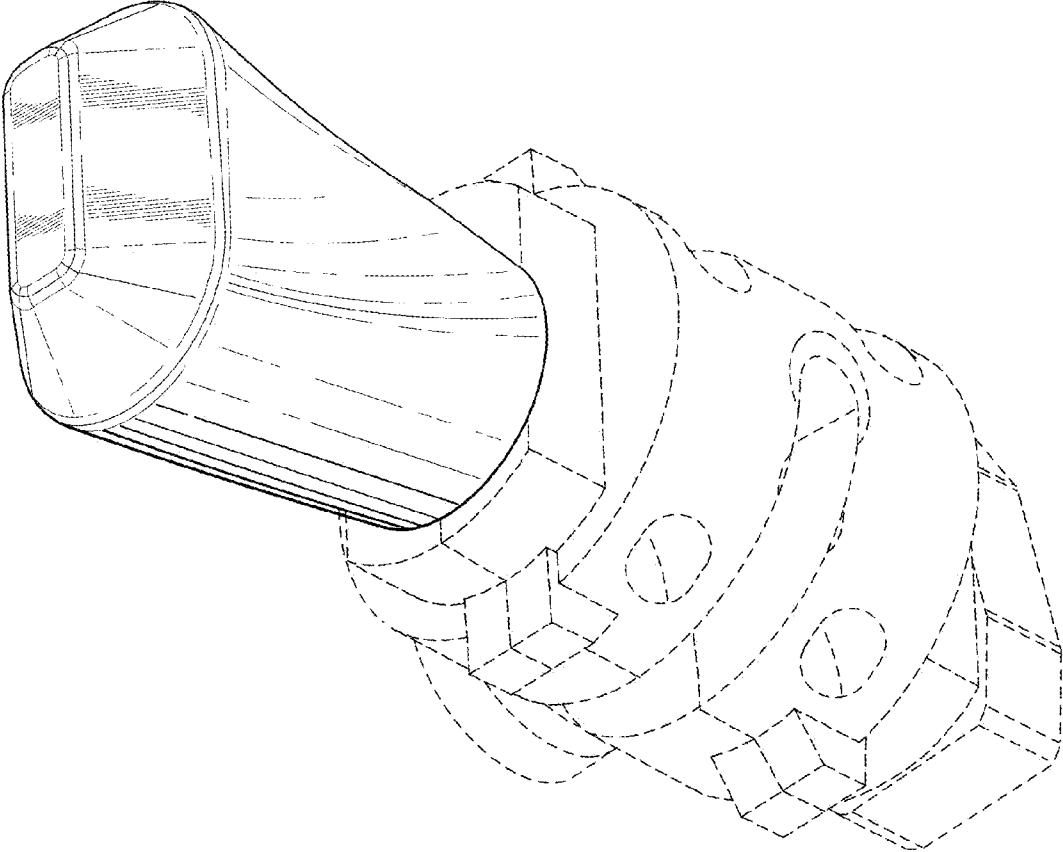

FIG. 1

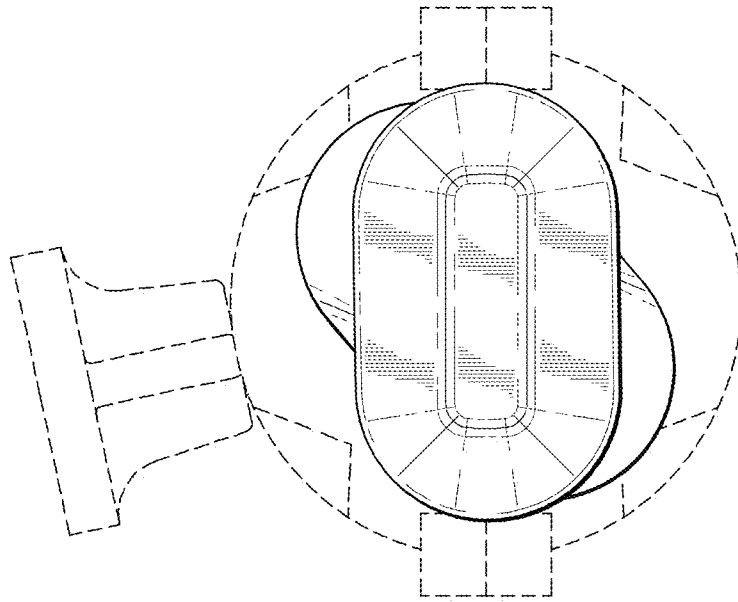

FIG. 2

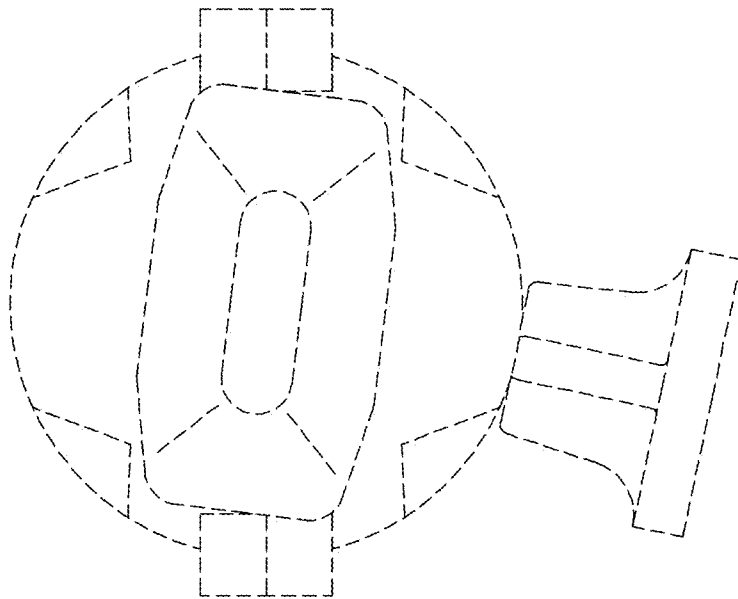

FIG. 3

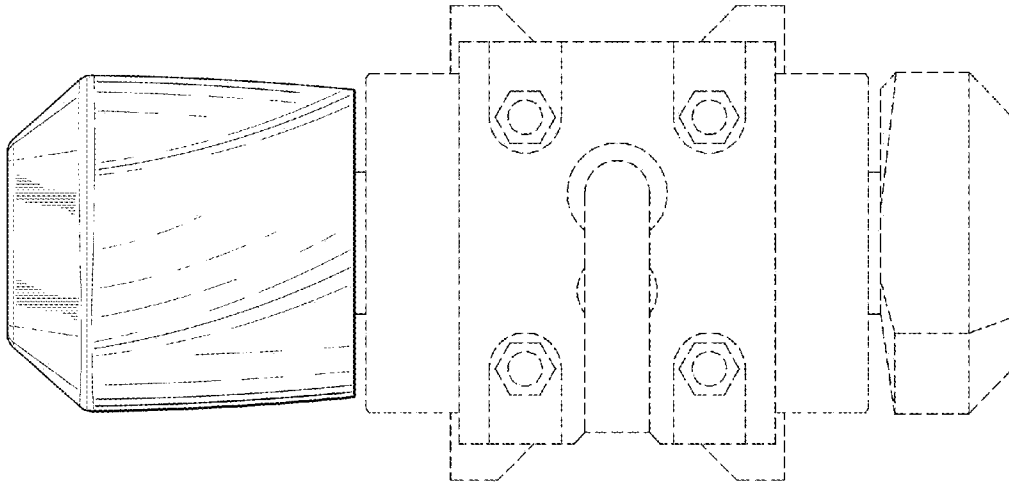

FIG. 4

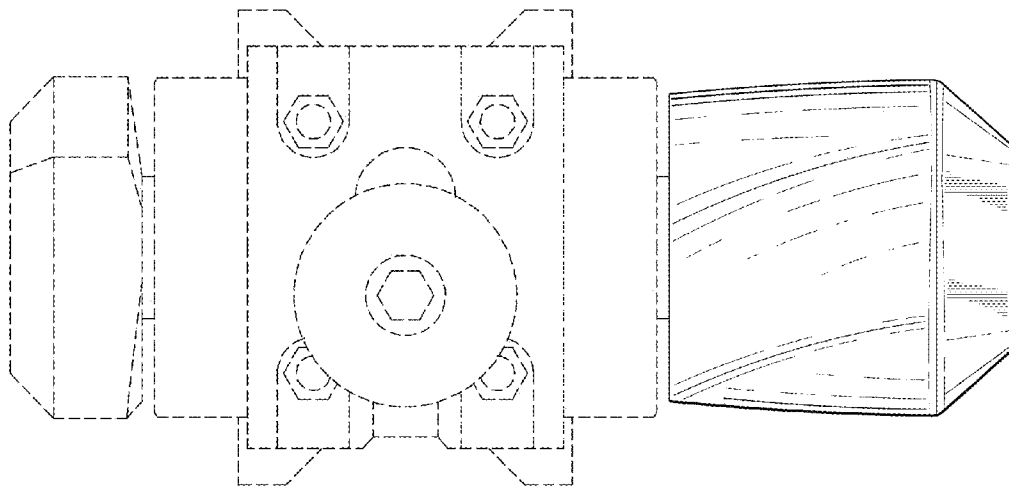

FIG. 5

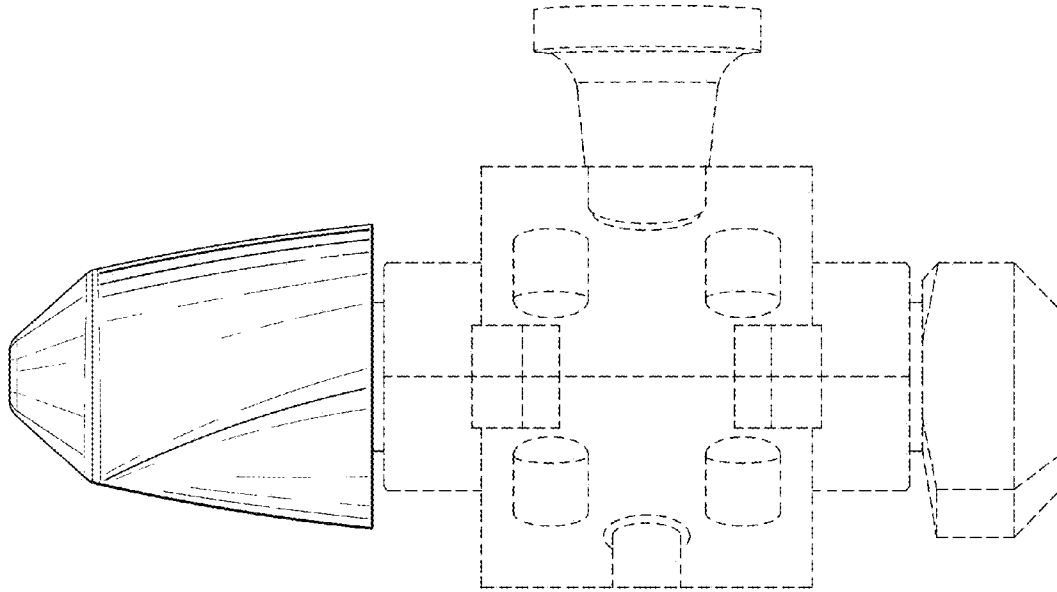

FIG. 6

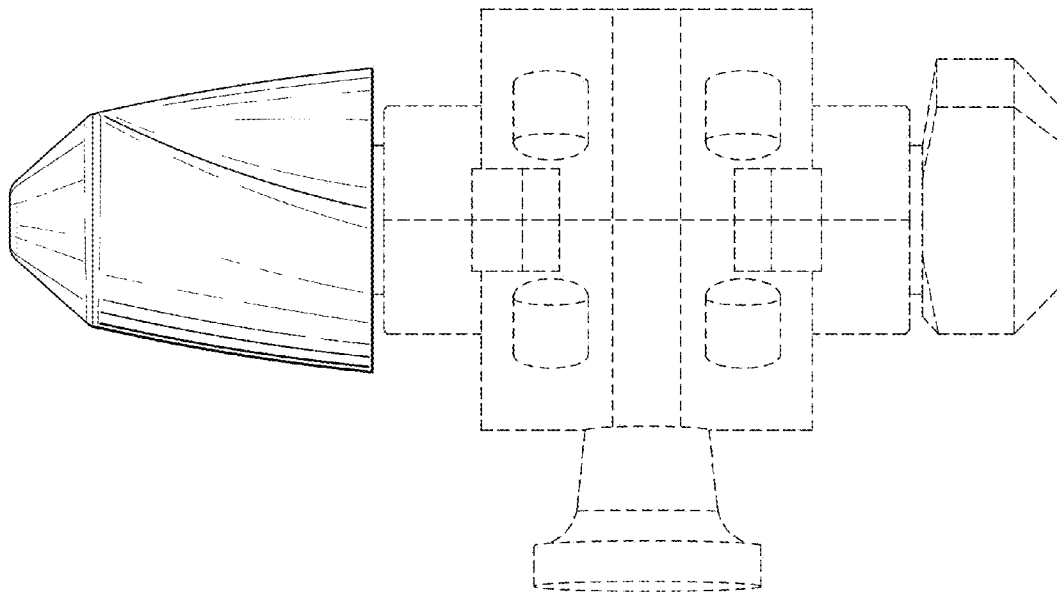

FIG. 7