

(19) World Intellectual Property  
Organization  
International Bureau



(43) International Publication Date  
9 December 2004 (09.12.2004)

PCT

(10) International Publication Number  
WO 2004/105839 A1

(51) International Patent Classification<sup>7</sup>: A61M 5/142,  
5/165

(21) International Application Number:  
PCT/GB2003/002339

(22) International Filing Date: 29 May 2003 (29.05.2003)

(25) Filing Language: English

(26) Publication Language: English

(71) Applicant and

(72) Inventor: GILL, Steven, Streatfield [GB/GB]; North  
Bristol NHS Trust, Frenchay Hospital, Frenchay Park  
Road, Bristol BS16 1LE (GB).

(74) Agents: TOMBLING, Adrian, George et al.; Withers &  
Rogers, Goldings House, 2 Hays Lane, London SE1 2HW  
(GB).

(81) Designated States (national): AE, AG, AL, AM, AT, AU,  
AZ, BA, BB, BG, BR, BY, BZ, CA, CH, CN, CO, CR, CU,

CZ, DE, DK, DM, DZ, EC, EE, ES, FI, GB, GD, GE, GH,  
GM, HR, HU, ID, IL, IN, IS, JP, KE, KG, KP, KR, KZ, LC,  
LK, LR, LS, LT, LU, LV, MA, MD, MG, MK, MN, MW,  
MX, MZ, NI, NO, NZ, OM, PH, PL, PT, RO, RU, SC, SD,  
SE, SG, SK, SL, TJ, TM, TN, TR, TT, TZ, UA, UG, US,  
UZ, VC, VN, YU, ZA, ZM, ZW.

(84) Designated States (regional): ARIPO patent (GH, GM,  
KE, LS, MW, MZ, SD, SL, SZ, TZ, UG, ZM, ZW),  
Eurasian patent (AM, AZ, BY, KG, KZ, MD, RU, TJ, TM),  
European patent (AT, BE, BG, CH, CY, CZ, DE, DK, EE,  
ES, FI, FR, GB, GR, HU, IE, IT, LU, MC, NL, PT, RO,  
SE, SI, SK, TR), OAPI patent (BF, BJ, CF, CG, CI, CM,  
GA, GN, GQ, GW, ML, MR, NE, SN, TD, TG).

Published:  
— with international search report

For two-letter codes and other abbreviations, refer to the "Guidance Notes on Codes and Abbreviations" appearing at the beginning of each regular issue of the PCT Gazette.

(54) Title: IMPLANTABLE PUMP

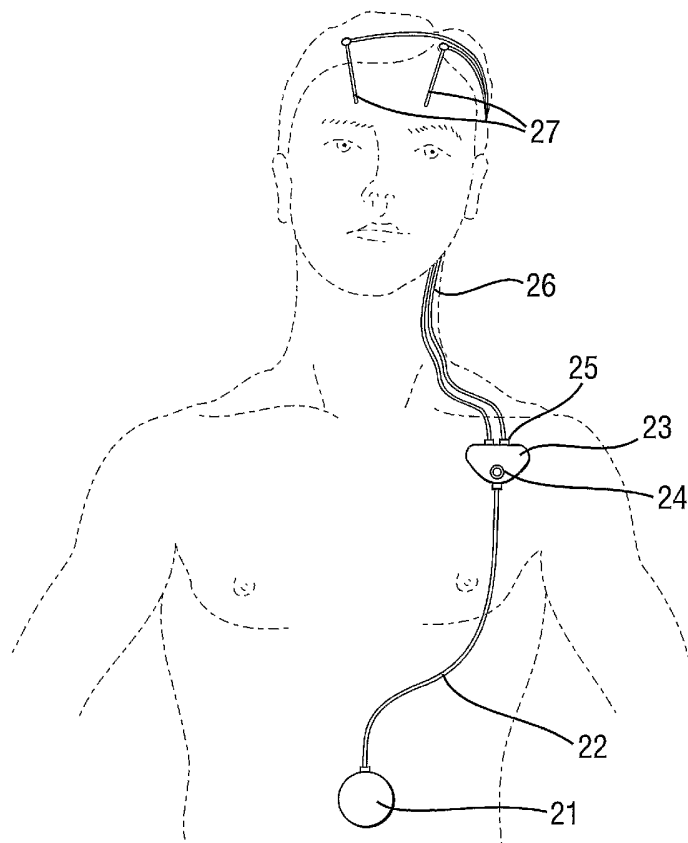

(57) Abstract: The pump includes a metering pump (23) including a rotor (24), at least two lengths of tubing (25) against which the rotor is movable to urge the drug therethrough, and an outlet port associated with each of the at least two lengths of tubing. In this way, a drug may be supplied to more than one neurological target.

WO 2004/105839 A1

## IMPLANTABLE PUMP

The present invention relates to an implantable drug delivery pump, a drug reservoir unit, and an implantable drug delivery system. Such pumps, units, or systems may be  
5 refilled with the drug, typically by percutaneous drug injections into reservoirs via body tissue.

Implantable drug delivery systems may be used for systemic or local delivery of drugs. Examples of systemic drug delivery include the regulated infusion of insulin into the  
10 body tissues for the treatment of diabetes and the infusion of Apomorphine for the treatment of advanced Parkinson's disease. The local delivery of drugs or therapeutic agents has particular application to the treatment of neurological conditions where the blood brain barrier prevents many systemically administered drugs from reaching the  
15 the desired target, or where the delivery of drugs or therapeutic agents to targets other than the desired target may produce unacceptable side affects. Examples of local drug delivery into the cerebrospinal fluid that surrounds the spinal cord and brain include the intrathecal delivery of opioids for chronic pain control and the intrathecal delivery of baclofen for the treatment of spasticity. Drugs and therapeutic agents may also be  
20 delivered directly into the brain parenchyma via a catheter whose discharge portion lies adjacent to a pre-determined target. Examples of this type of therapy include the infusion of gamma-amino-butyric acid agonists into an epileptic focus or pathway that will block its transmission, the delivery of cytotoxic agents directly into a brain tumour, and the infusion of neurotrophic agents for the protection and repair of failing or  
25 damaged nerve cells.

Intraparenchymal delivery of neurotrophins may be used to treat a variety of neurodegenerative disorders including Parkinson's disease, Alzheimer's disease and Amyotrophic Lateral Sclerosis, and may also be useful in stimulating the repair of  
30 damaged neural tissue after injury from trauma, stroke or inflammation.

Examples of drug delivery pumps are shown, for example, in US 4013074 and US 4692147, each of which describe drug filled reservoirs located within the pump which are positioned within a housing that contains a gas such that, when the reservoir is filled, the gas is compressed which in turn provides the pressure to empty the reservoir.

5 In particular, US 4692147 describes a battery powered motor driven pump which may be seen in Figures 1 to 3 of this specification. From Figure 1, it will be understood that the pump 1 is implanted subcutaneously, and that it may be refilled via a refill port 2 which may be accessed by percutaneous drug injection. The pump 1 includes an outlet port 3 through which the drug is pumped to an outlet tube 4.

10

Referring to Figure 2, it will be seen that the pump 1 includes a pump unit 5 beneath which is located a dish 6 which defines a reservoir. The pump unit 5 and the dish 6 are enclosed by top and bottom parts of a housing 7, 8. The pump unit 5 includes the drug refill port 2, batteries 9, and a roller pump 10.

15

Figure 3 shows the roller pump 10 in more detail. Within the roller pump 10 is a rotor 11 mounted for rotation within a pump housing 12. The rotor 11 includes two diametrically opposite arms, each of which terminates in a roller 13 which engages with a length of tubing 14 such that, as it rotates, the rollers 13 at the end of the rotor arms  
20 crush the length of tubing to drive the fluid through the length of tubing 14 as the rotor 11 rotates from an inlet 15 to an outlet 16. A flexible sheet 17 overlies the length of tubing 14, over which the roller 13 moves, the sheet 17 acting as a shim between the length of tubing 14 and the rollers 13. An example of a pump arranged in a similar way to that described in US 4692147 is the Synchronised EL pump (Medtronic Inc,  
25 Minneapolis).

Passive drug reservoirs are also known where regulators control the flow of fluid exiting a gas-pressurised drug filled reservoir. The energy required to deliver the drug to its target is imparted to the pump upon filling the reservoir and compressing the gas.  
30 The regulators are either coiled lengths of fine bore tubing or etched fluid conducting channels in a chip. Passive drug dispensers are less reliable in delivering the desired dose than mechanical dispensers since the dose of drug delivered by passive dispenser

depends upon the pressure in the drug filled reservoir, the resistance set by regulator, the resistance in the pump to catheter tubing, the resistance in the catheter, the pressure applied by the tissue (tissue turgor) at the catheter's delivery port, as well as the viscosity of the fluid being delivered. With passive drug dispensers, the accuracy of drug delivery is least reliable when the flow rates are low and the regulator needs to impart a high resistance. In these circumstances, small changes in the viscosity will have a significant bearing on the flow rate and the dose of drug delivered. For the delivery of neurotrophic factors into the brain parenchyma, low flow rates of the order of 1-10 $\mu$ l per hour are desirable and because neurotrophic factors are proteins in suspension, they will impart a higher viscosity than crystalloid drugs and alter the flow rate accordingly. Proteins in suspension may also have a tendency to deposit within the fine tubing or etched channels of the passive regulator and further influence the flow rate.

Thus, for the delivery of proteinaceous drugs and particularly the intraparenchymal delivery of neurotrophic factors to the brain, battery powered mechanical dispensers are preferable to passive dispensers. For safety as well as the ability to alter the dosing regimen as required, a pump that can be controlled by telemetry is also desirable. Of the battery powered mechanical pumps described in the prior art that are programmable using telemetry, all have the drug dispenser unit containing the battery or batteries, motor, dispensing actuator and electronics for programming housed with the pressurised drug filled reservoir. This tends to make the pumps bulky for subcutaneous implantation because the reservoir alone may contain between 10 and 24ml. The Synchronised EL pump contains a reservoir of 16ml, is cylindrical in shape and has a diameter of 7cm and a height of 2.9cm. Its size means that it is necessary to implant such pumps subcutaneously in the anterior abdominal wall where they are least obtrusive. Nevertheless, when implanted in thin patients, the bulk of the pump can cause considerable inconvenience and discomfort. If, on the other hand, the pump is deeply placed in the subcutaneous fat of an obese patient, finding the refill port can also be problematic. Minimising the volume of the reservoir of the pump has the disadvantage that the pump will require percutaneous refilling more frequently, thereby

increasing the necessity for the patient to attend a clinic, and increasing the risk of introducing infection.

To treat neurodegenerative disorders, brain injury or other disorders with neurotrophins  
5 it may be desirable to deliver them to more than one neurological site in the central nervous system, preferably the brain or spinal cord, most preferably the brain. For example, Parkinson's disease may be treated by infusing glial-derived neurotrophic factor (GDNF) delivered by one or more catheters implanted bilaterally into each dorsal putamen. Similarly, Alzheimer's disease may be treated by infusing nerve growth  
10 factor delivered by one or more catheters implanted bilaterally into each nucleus basalis.

Delivering the drug to multiple sites by implanting multiple pumps of the types described in the prior art would be unacceptable, and only US 5752930 discloses the  
15 delivery of a drug from a single pump to multiple sites. This teaches the fluid delivery through a single catheter with multiple ports. Such a device will not facilitate drug infusion bilaterally into the brain or to other sites other than those along the axis of the implanted catheter.

20 Each of the prior art documents referred to above are herein incorporated in their entirety by this reference.

Two or more catheters could be connected to the outflow tubing from a single pump via a single input/multiple output connector. Such an arrangement would not guarantee an  
25 even distribution of drug to each catheter because fluid will flow primarily down the catheter offering the least resistance. To overcome this, the connector would have to act as a regulator to ensure that resistance is overcome. This will put a great demand on the pump and will increase the stress on joints between the pump and the connector. For very low flow rates, such as one or two  $\mu\text{l}$  per hour, the outflow ports in such a  
30 connector acting as a regulator will need to be extremely small.

According to a first aspect of the present invention there is provided, an implantable drug delivery pump comprising a metering pump including a rotor, at least two lengths of tubing against which the rotor is movable to urge the drug therethrough, and an outlet port associated with each of the at least two lengths of tubing. In this way, the drug can be pumped from the pump to multiple targets in even quantities. In this specification, references are made to the pumping and delivery of drugs, and such references include all therapeutic agents including such substances as proteins, cytokines, neurotrophic agents, toxins to destroy cancerous tissue and therapeutic markers to assist in imaging targets.

10

The invention allows a drug to be delivered to more than one site. This may be for the reasons outlined above that both sides of the brain need to be treated in conditions such as Parkinson's disease and Alzheimer's disease, or because multiple sites of delivery within a target volume may be necessary to optimise the distribution of the therapeutic agent. It is generally the rule that equal volumes of the therapeutic agent will need to be delivered to each site. The pump of the present invention achieves this with the advantage of being both compact and energy efficient.

15

It is preferred that the metering pump includes a housing having an interior wall, and arranged such that each of the lengths of tubing is arranged between the rotor and the interior wall of the housing whereby the rotor urges the drug through the length of tubing.

20

It is also preferred that the rotor includes two rotor arms, and in some circumstances it is advantageous to include 3 rotor arms, or even 4 or more rotor arms.

25

The number of lengths of tubing that are included depends on the number of targets it is intended to deliver the drug to. In some circumstances, it is preferred to include between 3 and 6 lengths of tubing.

30

According to a preferred embodiment, the pump includes a motor for moving the rotor, and this motor is most preferably a stepper motor.

It is also advantageous for the rotor to carry a roller for engagement with the length of tubing. Lower resistance and reduced wear result from the use of the roller.

- 5 In an alternative embodiment, the lengths of tubing might be arranged to be of different diameters such that different flow rates are generated from different outlet ports. This will be of particular value where the treatment of different targets require different volumes of the drug to be delivered.
- 10 According to a second aspect of the invention there is provided, a drug reservoir unit comprising an outer housing; a reservoir container disposed within the outer housing and arranged to be variable in volume; and a port through which a drug may fill or exit from the reservoir container leading to a separately located pump. The reference to a separately located pump in this specification makes it clear that the reservoir unit is not
- 15 an integral part of the pump. In one embodiment, the reservoir container is in part defined by the outer housing, and it is preferred that in this case, the reservoir container is defined at least in part by a bellows.

In a second embodiment, the reservoir container is defined at least in part by a resilient

20 bladder. The bladder is preferably constructed from two resilient discs joined in face to face relationship at their peripheries. In such a case, the outer housing is advantageously dome-shaped. It should also be noted that the reservoir unit could include a refill port.

25 According to a third aspect of the present invention, there is provided an implantable drug delivery system comprising a drug reservoir unit for holding a drug, a pump unit disposed remotely from the drug reservoir unit and including a metering pump arranged for pumping the drug from the drug reservoir unit to a delivery zone; and a supply tube disposed between the pump unit and the drug reservoir unit.

30

By locating the pump unit and the drug reservoir separately, the pump unit will be more compact, and may allow a surgeon to implant it in a range of alternative locations where

it is comfortable and access to the refill port is improved. Also, by locating the drug reservoir unit separately, the unit may be arranged to hold a greater volume of the drug, thereby reducing the number of clinic visits for percutaneous refilling, and also reducing the risk of introducing infection. A limitation on the size of the reservoir is the stability of the drug because there is no valve in the reservoir being of greater capacity than the total volume of a drug that will be delivered at the prescribed rate before the drug begins to degrade.

The reservoir should preferably be located subcutaneously over the abdominal wall and most preferably within the rectus sheath, overlying the rectus muscles of the anterior abdominal wall because this will tend to reduce its prominence.

For drug delivery to the brain, it is preferable to position the pump close to the head. This minimises the length over which the pump outflow tubing needs to be tunnelled subcutaneously, reduces the dead space in the tubing and also reduces the resistance to the flow of fluid thereby improving energy efficiency for pump.

According to preferred embodiments, an outlet tube leads from the pump unit to the delivery zone. It is preferred that a plurality of outlet tubes lead to a plurality of delivery zones, so that treatment is optimized.

It is also preferred that the pump unit further includes a drug refill port through which the reservoir is filled. This is preferred because the pump unit may be unobtrusively implanted in the subclavicular region while the bulkier drug reservoir may be implanted in the abdominal wall. Whereas the anterior abdominal wall may contain considerable subcutaneous fatty tissue, the subclavicular region has comparatively little subcutaneous fat and so if the drug port is housed with the drug dispenser, it should be relatively easy to palpate percutaneously.

It is least intrusive, and therefore preferred if the drug refill port is arranged to fill the reservoir via the supply tube. Filling will result in the flow of the drug through the



supply tube in the opposite direction to the supply of the drug to the pump unit during drug delivery.

It is preferred that the system further comprise one or more neurosurgical catheters for  
5 delivering the drug to delivery zones.

A preferred embodiment of the present invention will now be described by way of example only, and with reference to Figures 4 to 17 in which:

10 Figure 4 is a schematic view showing an implantable drug delivery system according to the present invention;

Figure 5 is a rear view of a pump unit according to the present invention, with part of the casing removed to reveal the interior of the unit;

15

Figure 6 is a front view of the pump unit shown in Figure 5, but with the casing in place;

Figure 7 is an underside view of the pump unit of Figures 5 and 6;

20

Figure 8 is a partially exploded view of the pump unit of Figures 5 to 7;

Figure 9 is a more fully exploded view of the pump unit shown in Figures 5 to 8;

25 Figure 10 is a sectional view of a filter unit of the pump unit viewed from the front;

Figure 11 is a sectional view of part of the filter unit as viewed from below;

Figure 12 is an exploded view of a drug reservoir unit;

30

Figure 13 is a perspective view of the drug reservoir unit shown in Figure 12;

Figure 14 is a sectional view of the drug reservoir shown in Figures 12 and 13;

Figure 15 is an exploded view of an alternative form of drug reservoir according to the present invention;

5

Figure 16 is a perspective view of the reservoir of Figure 15;

Figure 17 is a sectional view through the reservoir unit shown in Figures 15 and 16.

10 Figure 4 is a schematic view showing an implantable drug delivery system. A reservoir unit 21 is shown implanted subcutaneously over the anterior abdominal wall of a patient, and preferably within the rectus sheath anterior to the rectus muscle. The reservoir unit 21 has the purpose of holding a volume of a drug for infusion, and since the unit 21 is quite bulky in order to retain as much drug as possible, such a location is very suitable. Leading from the reservoir unit 21 is a supply tube 22 which leads to a  
15 pump unit 23. The supply tube 22 is tunnelled subcutaneously between the reservoir unit 21 and the pump unit 23. The pump unit 23 is subcutaneously implanted in the subclavicular region. Implantation at this location is possible since the pump unit 23 is compact, made possible by the remote location of the reservoir unit 21. This location  
20 for the pump unit 23 is particularly advantageous since it should not prove to be inconvenient or uncomfortable to the patient, and yet it is close enough to the surface of the body that percutaneous refilling is relatively easy. It will be seen from Figure 4 that the pump unit 23 includes a refill port 24 on its front surface through which it is easy to palpate. The pump unit 23 includes one or more outlet ports 25 from which the drug is  
25 pumped into one or more outlet tubes. The outlet tubes 26 lead to intraparenchymal catheters 27 which are implanted in the brain of the patient.

Intraparenchymal catheters are known in the field of neurosurgery for infusing drugs to particular parts of the brain. The catheters are rigid tubes which are inserted  
30 stereotactically and secured to the skull with their distal ends in the vicinity of targets to be treated within the brain. The intraparenchymal catheters 27 are connected to the outlet tubes 26 which are tunnelled subcutaneously through the scalp and neck.

It will be understood that, while there are often major advantages to delivering a drug to more than one target within the brain, the advantages of locating the reservoir unit 21 and the pump unit 23 separately can also be extremely advantageous where a drug is delivered to just one target.

Once the drug delivery system has been installed in the body of the patient, the reservoir unit 21 may be filled by inserted a hypodermic needle through the skin of the patient through the refill port 24. The drug can then be inserted into the pump unit 23 where it is directed through the supply tube 22 to the reservoir unit 21. The reservoir unit 21 is arranged such that the drug contained therein is held there under a pressure which urges the drug upwards to the pump unit 23. This way, the pump unit 23 merely pumps the drug from the pump unit 23 to the target, and does not have to draw the drug from the reservoir unit 21. This will clearly reduce the power consumed by the pump unit 23 and assist in preserving battery life. The speed and operation of the pump unit 23 can be pre-set, although it is preferable for it to be telemetrically controlled from outside of the patient's body. During pumping, the drug is pumped at a steady rate from the outlet ports 25, via the outlet tubes 26 to the neurosurgical catheters 27 where the drug is released at the target to be treated. In certain applications, the flow rate of the drug being administered may be of the order of one to ten  $\mu$ l per hour.

Referring to Figures 5 to 9, the pump unit 23 is shown including the outlet ports 25 in the form of connectors for connecting to lengths of tubing. The pump unit 23 also includes an inlet port 28 in the form of a connector whereby the supply tube 22 may be connected. Within the pump unit 23 is located a battery 29, a roller pump 30, a refill port/filter unit 31 and two electronics modules 32. From Figure 5 it will be seen that the roller pump 30 includes a housing 33 having a curved interior wall, a rotor 34 rotatable within the housing and arranged with two diametrically opposite rotor arms each of which ends in a roller 35. A dual length of tubing 36 is disposed against the curved interior wall of the housing 33 such that the rollers 35 crush the tubing 36 against the interior wall of the housing 33. When the rotor 34 is rotated, the rollers 35 roll over the dual length of tubing 36 so as to urge any fluid within the tubing

therethrough. It is this which generates the pumping of fluids through the drug delivery system. Although not shown in the drawings, a shim or flexible sheet is disposed over the tubing 36 such that the rollers 35 do not bear directly on the tubing 36, but on the shim, thereby reducing wear on the tubing 36. An example of a shim is shown in  
5 Figure 3. The rotor 34 is rotated by a stepper motor (not shown), although other suitable motors could be used. It will be understood that a dual length of tubing 36 is one where two tubes extend side by side, as is seen in Figure 9.

It will be appreciated that the inlet port 28 leads fluid from the reservoir unit 21 via the  
10 supply tube 22 into the roller pump 30. Since the length of tubing 36 within the roller pump 30 is duelled, this means that one inlet line can be converted to two outlet lines. In this regard, it will be seen that there are two outlet ports 25, each connected to one of the lengths of tubing 36 passing through the roller pump 30. In Figure 5, only one of the lengths of tubing 36 through the roller pump 30 can be seen since the length of  
15 tubing will be stacked axially with respect to the axis of rotation of the rotor, but the tubing 36 is best seen in Figure 9. Of course, the use of two lengths of tubing 36 means that the same volume of a drug will be delivered to two different targets. Of course, more lengths of tubing may be incorporated here, each of which is acted upon by the roller 35 of the rotor 34 in order to pump the drug to each site that it is desired to pump  
20 the drug to. In fact, if different sites required different volume of the drug to be delivered to them, the length of tubing 36 passing through the roller pump 30 can be arranged to have different internal diameters, thereby allowing pumping at different rates through different lengths of tubing. Further details of the refill port 24 and the filler unit will be described later in the specification.

25

Figure 9 shows a more exploded view of the pump unit. It will be seen that, in alignment with the refill port 24, is a filter element 37 and a silicone rubber seal 38. The seal 38 closes the port 24 so that nothing can pass either way through the port 24 unless it is inserted using a hypodermic needle from outside. The seal is able to form a  
30 seal around the hypodermic needle during filling of the system, and once the needle has been removed, the hole that the needle made will be securely sealed closed again in

order prevent foreign bodies from entering the system, and to prevent the drug from escaping from within the system.

During filling, the tip of the hypodermic needle is located within the central well of the  
5 filter element 37, and during filling, the drug must pass through a cylindrical bacterial  
filter 39 that is arranged around the outside of the filter element, and is, in this case,  
fluted. The filter element is arranged like a reel.

During filling, the drug from the hypodermic needle is forced through the fluted  
10 bacteriological filter 39 and is directed down through the supply tube 22 into the  
reservoir unit 21. The filter prevents any particulate matter within the drug that is  
inserted from being passed into the rest of the system, the particulate matter being  
retained within the filter element 37. The particulate matter can be fragments of skin,  
hair or bacteria, for example. Implantable pumps require a filter to screen out the  
15 particulate matter. Fine filters provide resistance to the flow of fluid, and to reduce this,  
the surface area is maximised. Whereas it is known to use large discs of porous  
material through which the fluid is passed, this necessarily occupies a relatively large  
space where space is at a premium. The filter in the present invention is very compact  
and is positioned at the refill port rather than between the reservoir and the pump, and  
20 so prevents any particulate matter from entering the reservoir in the first place. When  
the system is emptied by aspirating through the refill port, particulate matter may be  
flushed out of the filter, and so help clean it. The resistance offered by the filter in the  
present invention is overcome when fluid is injected into the refill port and avoids the  
increase in demand on the pressurised reservoir to overcome the filter resistance which  
25 is inherent in the teaching of the prior art. The increased resistance in the prior art may  
contribute to a fall off in the pressure of fluid delivery to the pump as the reservoir  
becomes depleted, and may contribute to inaccuracies in drug delivery. The bacterial  
filter is intended to have a four micron mesh size.

30 The pump unit is closed by a lower casing 30A and an upper casing 30B, each of which  
is made of titanium. The various components shown in Figure 9 are spot welded to  
pins located within the upper casing 30B. The refill port 24 is pressed onto the interior

surface of the upper casing 30B prior to laser welding the two halves of the casing together.

In the upper casing 30B, an alarm unit 41 can be seen which might be used to draw the patient's attention to some potential problem with the system.

Figures 10 and 11 show the filter unit 31 in more detail with the filter element 37 mounted in place. The seal 38 can clearly be seen in Figure 11, through which the drug is injected. It can also be seen that the inlet port 28 extends from the filter unit 31 so that the drug, on its way to the patient from the reservoir unit 21 passes through the filter unit 31 on its way to the roller pump 30.

Figures 12, 13, and 14 show a first design of a reservoir unit 47. The reservoir unit includes a top casing 42 which is cylindrical in shape, closed at one end, a bottom plate arranged to close the open top of the top casing 42, and bellows 44 located within the top casing and bottom plate. The bottom plate 43 includes an inlet/outlet port 45 through which the drug passes to fill the reservoir unit, and to lead via the supply tube 22 to the pump unit 23. The bottom plate 43 and bellows 44 define a sealed fluid reservoir. The space outside of the fluid reservoir, but within the housing, is also sealed and contains a small amount of fluorocarbon fluid or other volatile fluid that will provide positive pressure against the bellows sufficient to force the liquid out of the reservoir via the inlet/outlet port 45 towards the pump 23. The reservoir unit may be of any suitable size depending on the requirements of the individual patient. Typical volumes of the reservoir may be 10ml, 20ml or 30ml. The reservoir would preferably have a low profile with rounded edges in order to be as unobtrusive as possible to the patient. The top case in 42 and the bottom plate 43 are titanium.

Figures 15, 16 and 17 show a second embodiment of reservoir. This reservoir includes a domed lower casing 51, a domed upper casing 52 and a resilient bladder 53 disposed there between. The bladder 53 is constructed from two polyurethane discs placed face to face and sealed around their peripheries. The bladder 53 includes an inlet/outlet port 54 for connection to the supply tube 22 leading to the pump unit 23. The space outside

of the bladder, but within the casing 51, 52 is a partial vacuum. The bladder 53 has sufficient resilience to expel any drug, and the partial vacuum ensures constant outflow pressure.

5 The materials used for various components of the system must be those which are most tolerable to the body of the patient in order to reduce the risk of rejection systems. It is for this reason that the casings of the pump unit and the reservoir unit are constructed from titanium, although other materials might also be suitable.

10 The inlet port 28 and the outlet ports 25 to the pump unit 23, and the inlet/outlet port 45, 54 of the reservoir unit are, in this embodiment, in the form of a nipple over which the various tubes must be forced and subsequently compressed by tightening a ligature, a crimped ring, a deformed washer that is compressed by a threaded encircling nut, or by other suitable means.

15

It will be appreciated that the modular nature of the drug delivery system means that, if the pump unit 23 were to fail, or the battery to run down, the pump unit 23 may be surgically replaced whilst leaving the reservoir unit 21 and the neurosurgical catheters 27 in place. The new pump unit is merely reconnected to the various tubes. Also, the modular arrangement allows a pump to be used in a system with a variety of different types and sizes of reservoir. A smaller reservoir is suitable where very low flow rates are to be used, and where the drug being used has a short storage life. Also, if the reservoir needs to be replaced, this can be done without disturbing the rest of the system. Such a modular arrangement would be just as suitable if there were only one outlet port 25 leading from the pump unit 23.

20  
25

Certain drugs which are used for delivery to parts of the body are inherently toxic, or have serious side effects. Therefore, such drugs are normally delivered in a composition including a neutralising substance. However, the storage life of the composition tends to be much shorter than the storage life of the drug on its own. As a result, in the present invention, the drug can be stored in one reservoir, and the neutralising substance in another, and outlets from each of the reservoirs can lead to

30

inlets to the pump. The pump will then pump the two substances in the appropriate proportions, such that, after pumping, the two substances are allowed to mix and are fed through the system to the catheter for delivery. It will be appreciated that the mixing proportions will be controlled by the sizes of the respective length of tubing passing  
5 through the pump.

As explained above, although the present embodiment includes two outlet ports 25, the roller pump 30 can be arranged such that the rotor passes over more lengths of tube in order to pump the drug to more targets within the body such as the spinal cord.

10

The rotor 34 in the present embodiment includes two arms, each of which terminates in a roller. However, it is possible to increase the number of rollers above two.

Since the pump unit may be controlled by non invasive telemetry, the rate of rotation of  
15 the rotor can be adjusted to adjust the rate of which the drug is delivered.



**Claims**

1. An implantable drug delivery pump comprising:  
a metering pump including a rotor, at least two lengths of tubing against which the  
5 rotor is moveable to urge the drug therethrough; and an outlet port associated with each  
of the at least two lengths of tubing.
2. An implantable drug delivery pump according to claim 1, wherein the metering  
pump includes a housing having an interior wall, and each of the lengths of tubing is  
10 arranged between the rotor and the interior wall of the housing whereby the rotor urges  
the drug through the lengths of tubing.
3. An implantable drug delivery pump according to claim 1 or 2, wherein the rotor  
includes two rotor arms.  
15
4. An implantable drug delivery pump according to claim 1 or 2, wherein the rotor  
includes three rotor arms.
5. An implantable drug delivery pump according to claim 1 or 2, wherein the rotor  
20 includes four rotor arms.
6. An implantable drug delivery pump according to any one of the preceding claims,  
wherein the metering pump includes between three and six lengths of tubing.
- 25 7. An implantable drug delivery pump according to any one of the preceding claims,  
further comprising a motor for moving the rotor.
8. An implantable drug delivery pump according to any one of the preceding claims,  
wherein the rotor carries a roller for engagement with the lengths of tubing.  
30
9. An implantable drug delivery pump according to any one of the preceding claims,  
further comprising a refill port through which a drug is insertable.

10. An implantable drug delivery pump according to claim 9, wherein the refill port includes a seal.
- 5 11. An implantable drug delivery pump according to claim 9 or 10, further comprising a filter unit through which the inserted drug passes.
12. An implantable drug delivery pump according to claim 11, wherein the filter unit is cylindrical with a central filling well.
- 10 13. An implantable drug delivery pump according to claim 12, wherein the filter unit includes a fluted filter.
14. An implantable drug delivery pump according to claim 11 or 12, wherein the filter  
15 is a bacteriological filter.
15. A drug reservoir unit comprising:  
an outer housing;  
a reservoir container disposed within the outer housing and arranged to be variable  
20 in volume; and  
a port through which a drug may fill or exit from the reservoir container leading to a separately located pump.
16. A drug reservoir unit according to claim 15, wherein the reservoir container is in  
25 part defined by the outer housing.
17. A drug reservoir unit according to claim 15 or 16, wherein the reservoir container is defined, at least in part, by a bellows.
- 30 18. A drug reservoir unit according to claim 15 or 16, wherein the reservoir container is defined, at least in part, by a resilient bladder.

19. A drug reservoir unit according to claim 18, wherein the bladder is constructed from two resilient discs joined in face to face relationship at their peripheries.
20. A drug reservoir unit according to claim 18 or 19, wherein the outer housing is dome-shaped.
21. An implantable drug delivery system comprising:  
a drug reservoir unit for holding a drug;  
a pump unit disposed remotely from the drug reservoir unit and including a metering pump arranged for pumping a drug from the drug reservoir unit to a delivery zone; and  
a supply tube disposed between the pump unit and the drug reservoir unit.
22. An implantable drug delivery system according to claim 21, further comprising an outlet tube leading from the pump unit to the delivery zone.
23. An implantable drug delivery system according to claim 22, wherein a plurality of outlet tubes are arranged to lead to a plurality of delivery zones.
24. An implantable drug delivery system according to any one of claims 21 to 23, wherein the pump unit further includes a drug refill port through which the reservoir is filled.
25. An implantable drug delivery system according to claim 24, wherein the drug refill port is arranged to fill the reservoir via the supply tube.
26. An implantable drug delivery system according to any one of claims 21 to 25, further comprising one or more neurosurgical catheters for delivering the drug to delivery zones.
27. An implantable drug delivery system according to any one of claims 21 to 26, wherein the pump unit is arranged with the features of any one of claims 1 to 14.

28. An implantable drug delivery system according to any one of claims 21 to 27, wherein the reservoir unit is arranged with the features of any one of claims 15 to 20.
- 5 29. A method of delivering a drug using the apparatus of any one of claims 1 to 28.
30. The pump according to any one of claims 1 to 14 for use in therapy.
31. The system according to any one of claims 21 to 28 for use in therapy.
- 10 32. The use of a pump according to any one of claims 1 to 14 for the delivery of a therapeutic agent to a plurality of delivery sites.
33. The use of a system according to any one of claims 21 to 28 for the delivery of a  
15 therapeutic agent to a plurality of delivery sites.

FIG. 1

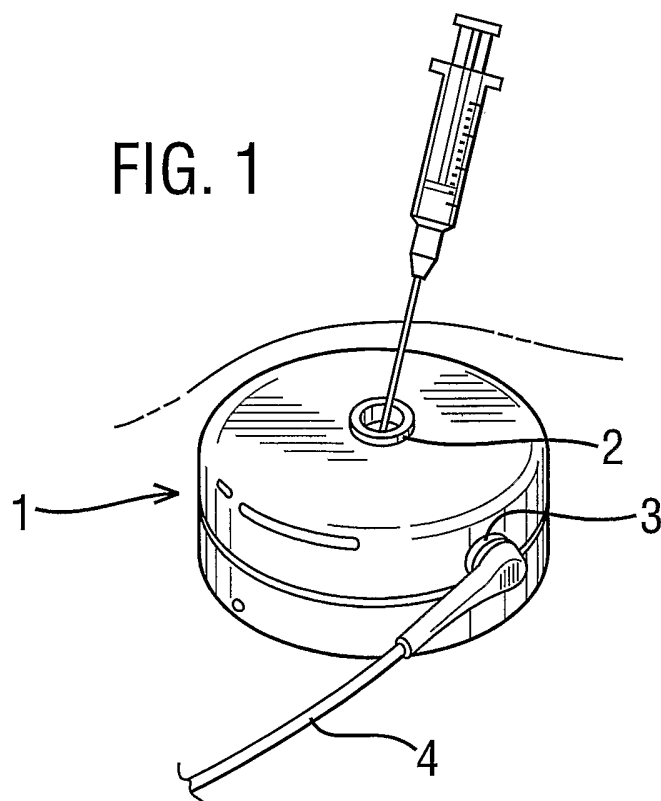
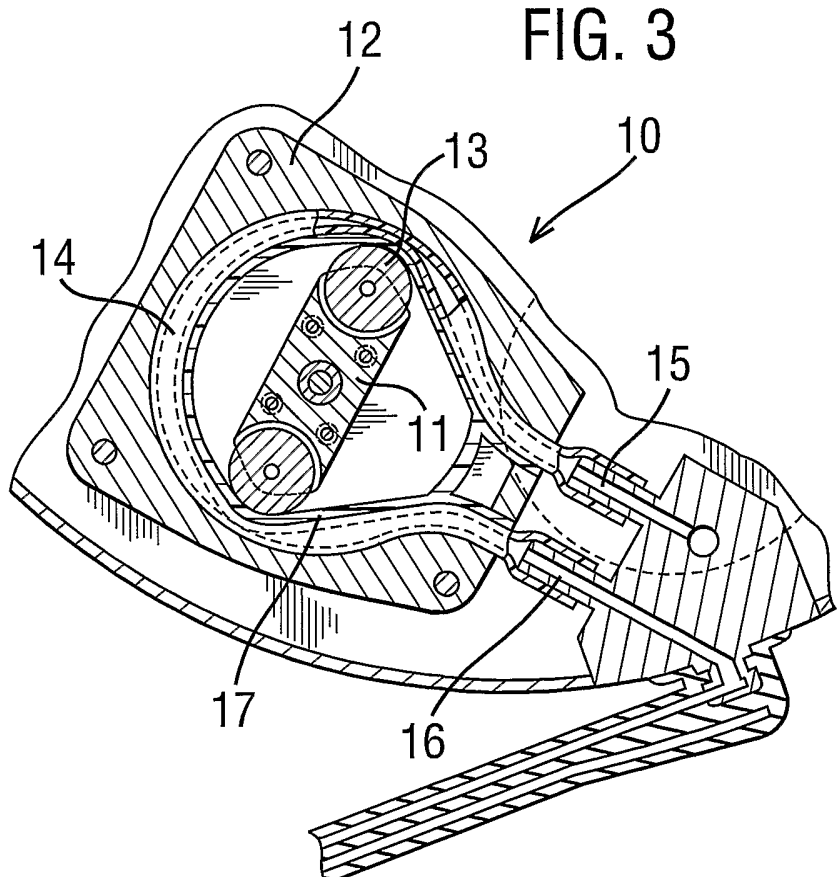

FIG. 3



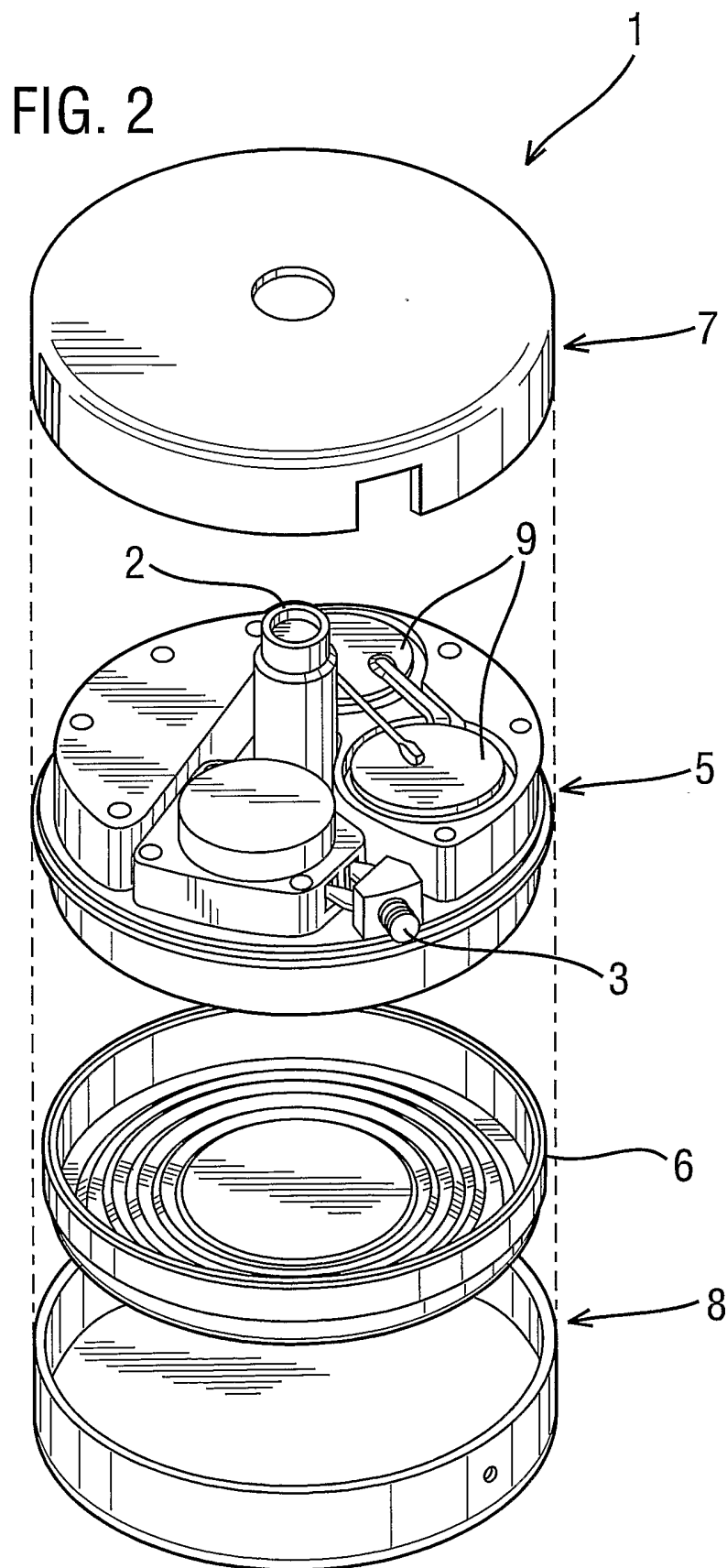
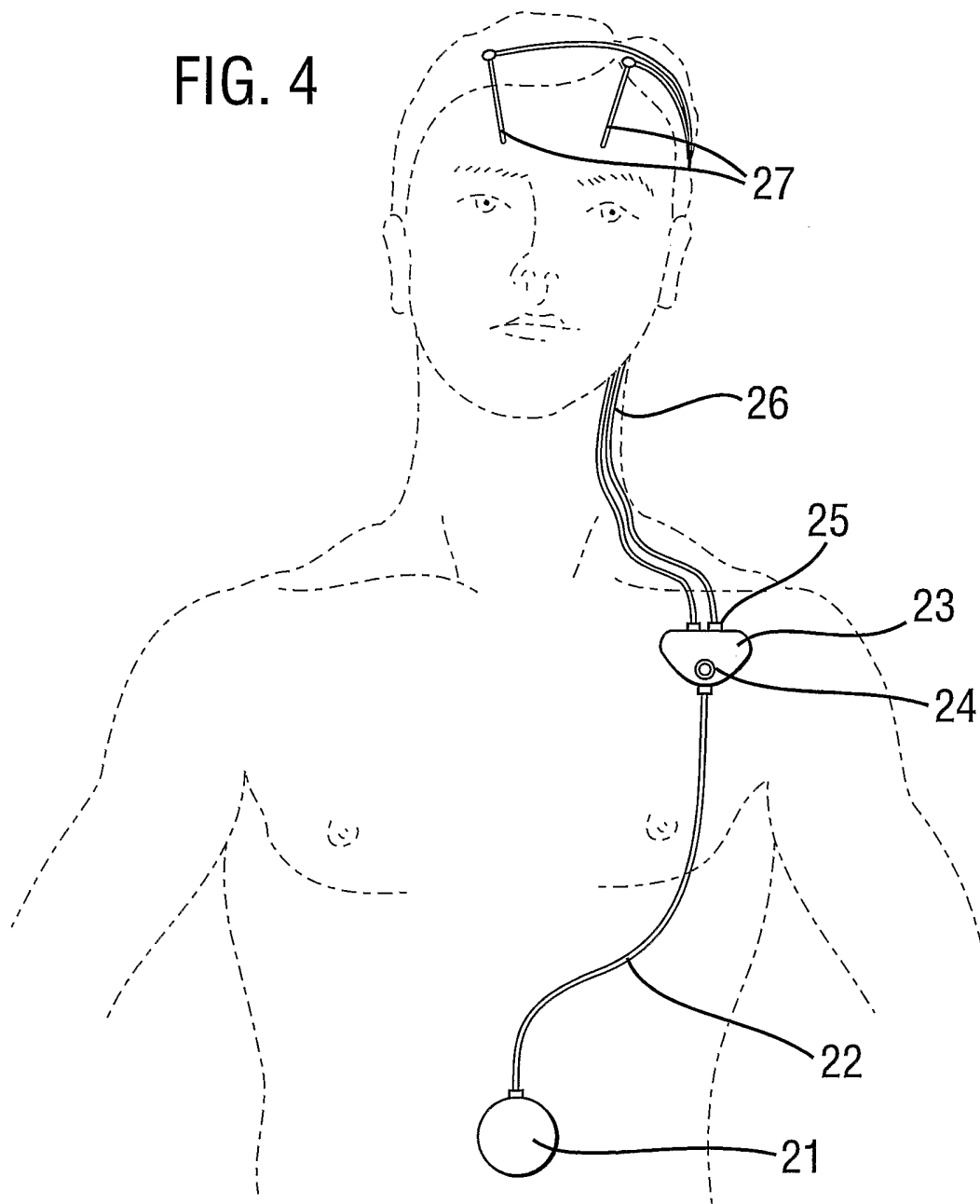

FIG. 4



4/9

FIG. 5

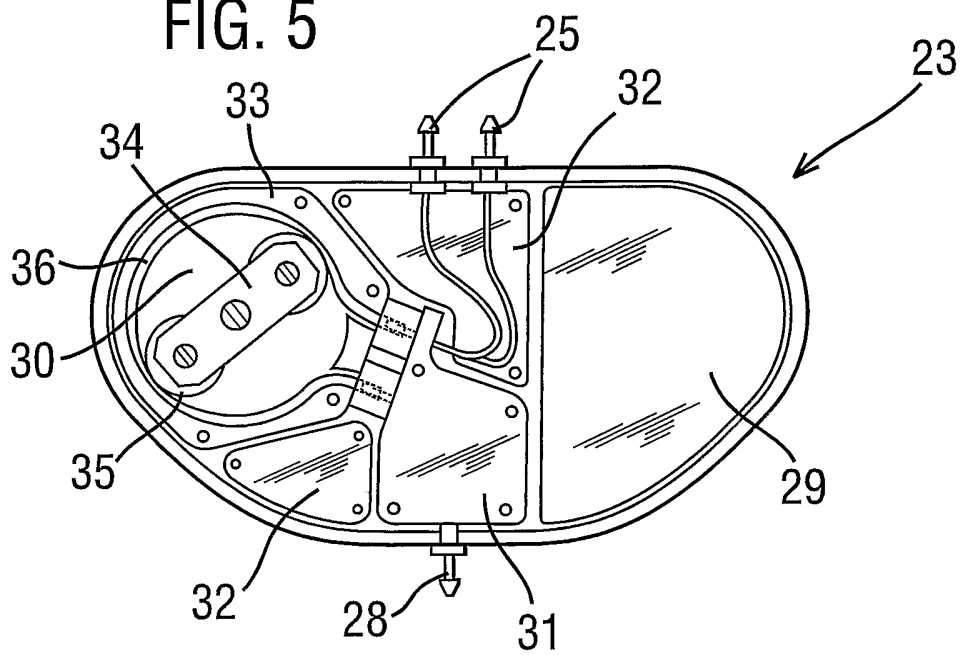

FIG. 6

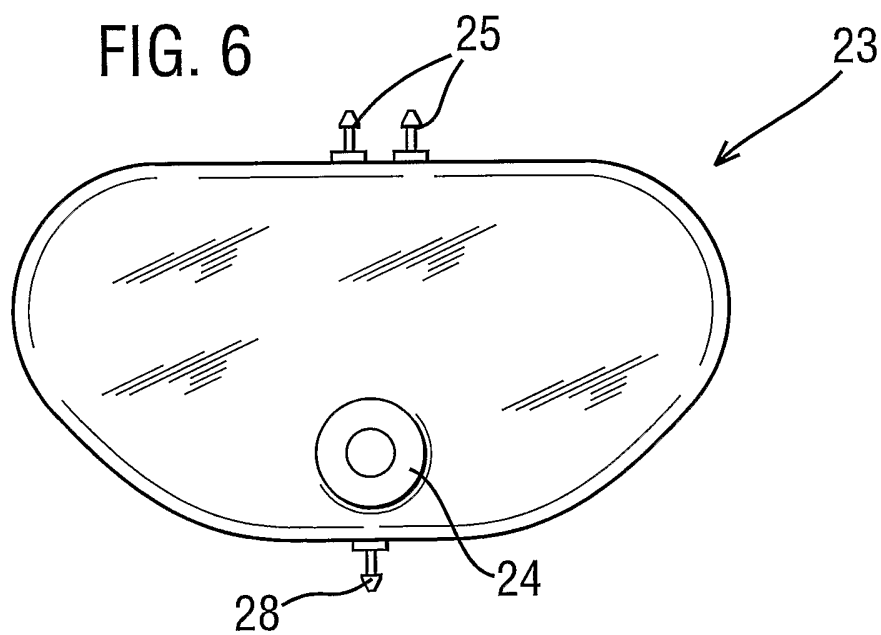

FIG. 7

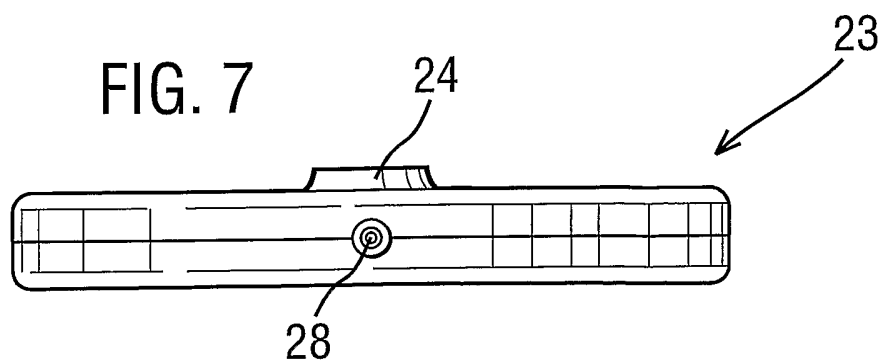
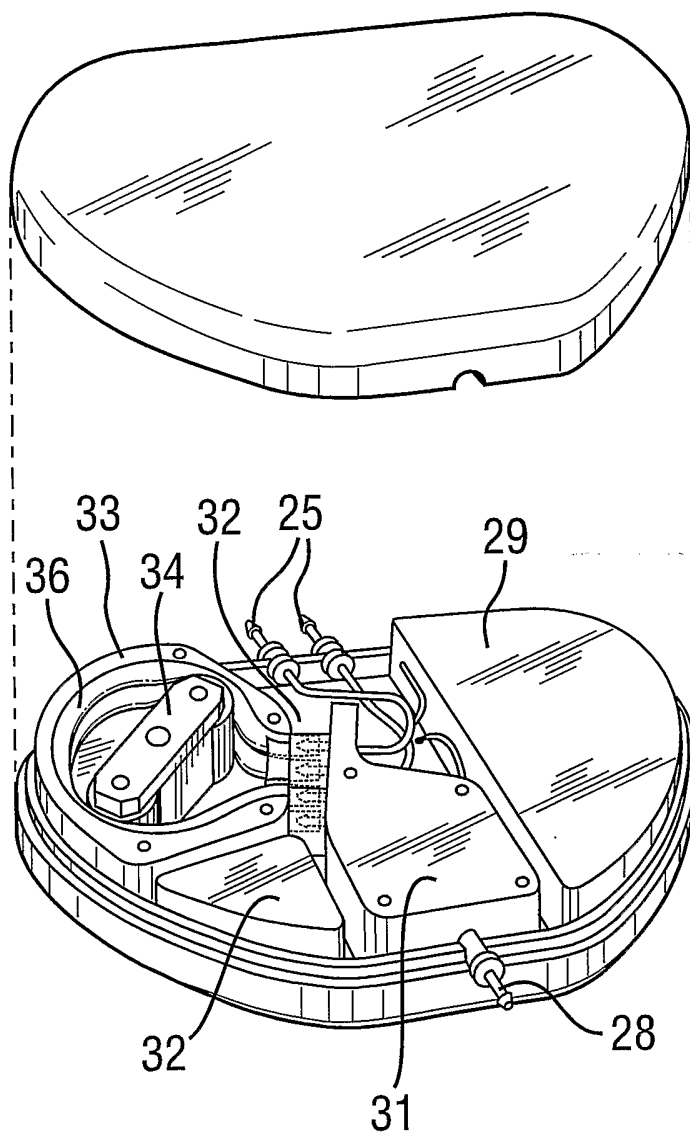



FIG. 8



6/9

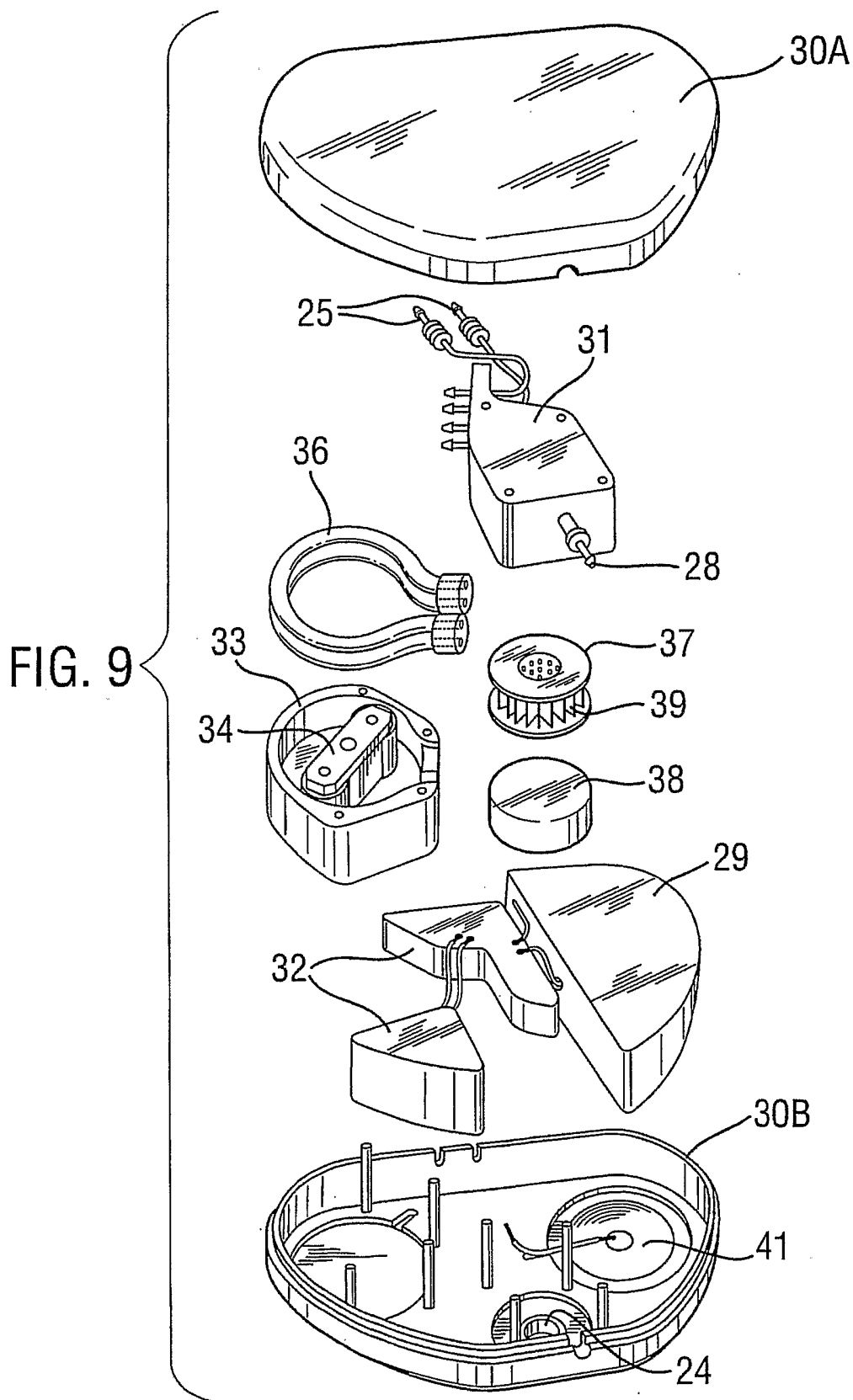

FIG. 10

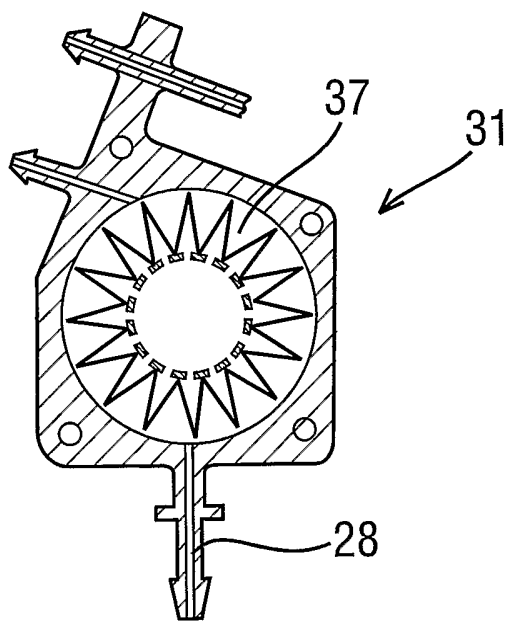
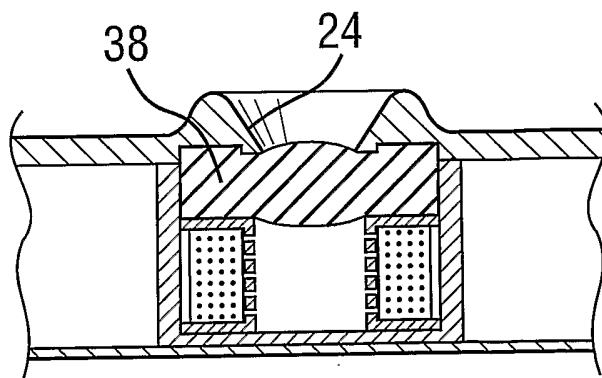
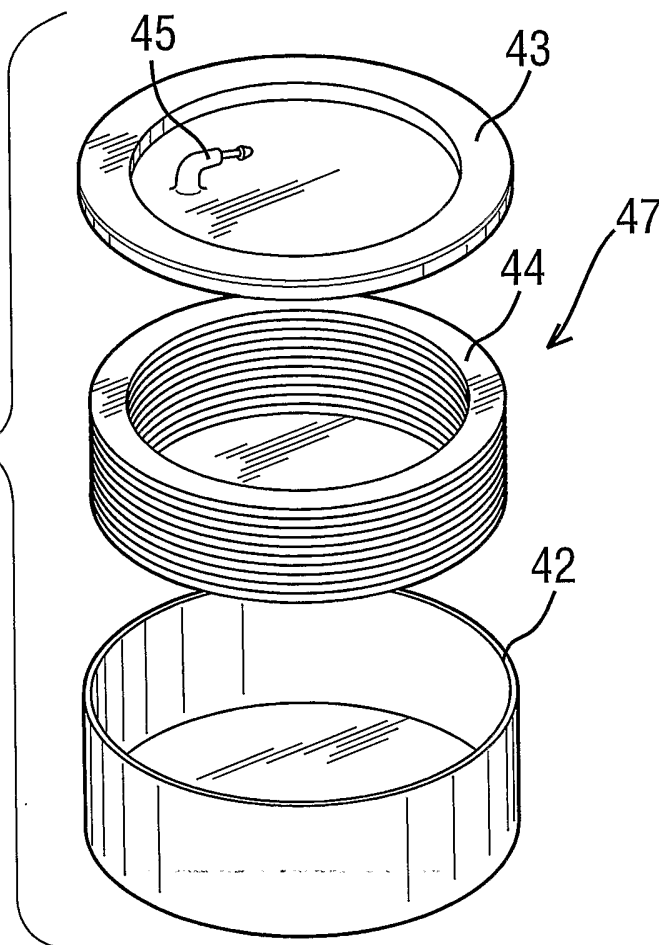

FIG. 11



8/9

FIG. 12



47 FIG. 13

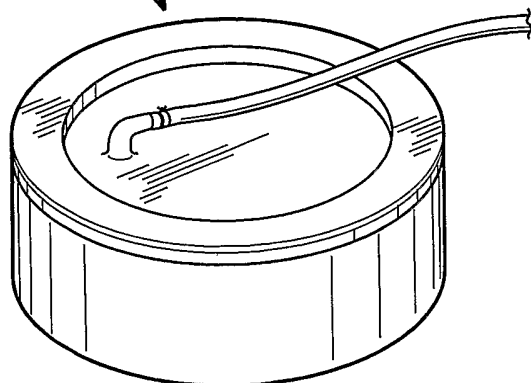
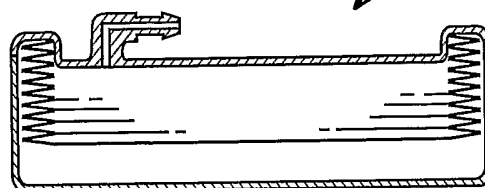
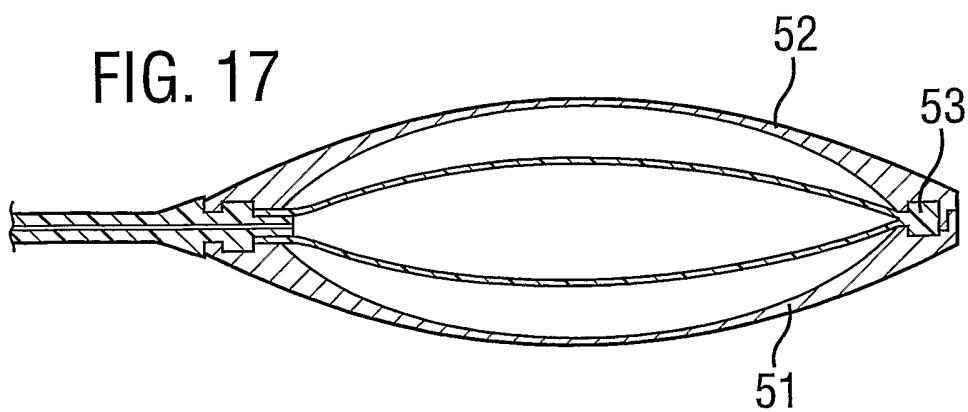
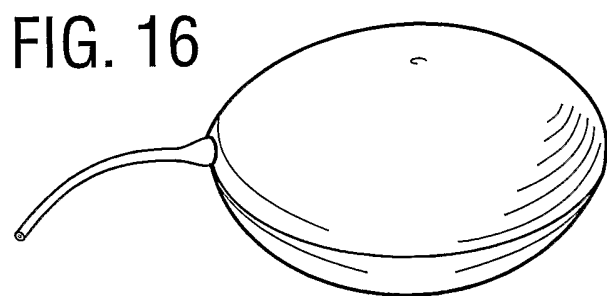
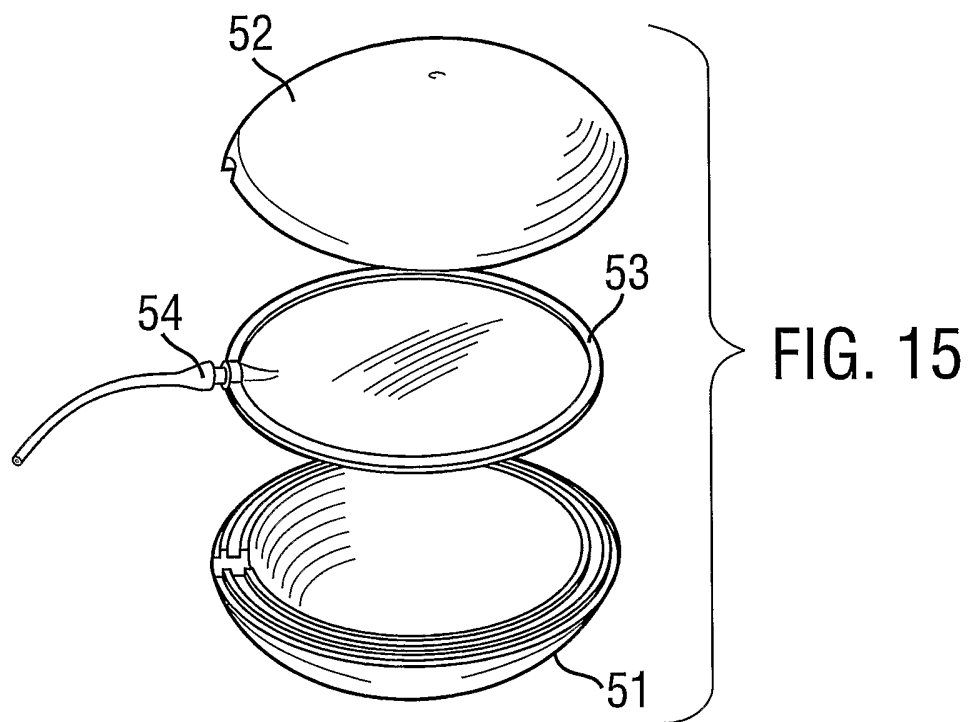

FIG. 14 47



9/9



# INTERNATIONAL SEARCH REPORT

International Application No  
PCT/GB 03/02339

**A. CLASSIFICATION OF SUBJECT MATTER**  
IPC 7 A61M5/142 A61M5/165

According to International Patent Classification (IPC) or to both national classification and IPC

**B. FIELDS SEARCHED**  
Minimum documentation searched (classification system followed by classification symbols)  
IPC 7 A61M

Documentation searched other than minimum documentation to the extent that such documents are included in the fields searched

Electronic data base consulted during the international search (name of data base and, where practical, search terms used)  
EPO-Internal

**C. DOCUMENTS CONSIDERED TO BE RELEVANT**

Category °	Citation of document, with indication, where appropriate, of the relevant passages	Relevant to claim No.
Y	US 5 752 930 A (BAUDINO MICHAEL D ET AL) 19 May 1998 (1998-05-19) cited in the application the whole document -----	1-9,30
Y	US 2002/029018 A1 (JEFFREY PETER) 7 March 2002 (2002-03-07) paragraph [0058]; figures 12A,B -----	1-9,30
Y	US 3 951 147 A (PROSL FRANK ET AL) 20 April 1976 (1976-04-20) column 4, lines 26-51 column 6, lines 16-33; figure 2 -----	10-14
Y	US 5 957 890 A (MCCONNELL SUSAN M ET AL) 28 September 1999 (1999-09-28) column 6, line 57 - column 7, line 32; figures 2,8 -----	10-14
	-/--	

Further documents are listed in the continuation of box C.       Patent family members are listed in annex.

° Special categories of cited documents :

<p>"A" document defining the general state of the art which is not considered to be of particular relevance</p> <p>"E" earlier document but published on or after the international filing date</p> <p>"L" document which may throw doubts on priority claim(s) or which is cited to establish the publication date of another citation or other special reason (as specified)</p> <p>"O" document referring to an oral disclosure, use, exhibition or other means</p> <p>"P" document published prior to the international filing date but later than the priority date claimed</p>	<p>"T" later document published after the international filing date or priority date and not in conflict with the application but cited to understand the principle or theory underlying the invention</p> <p>"X" document of particular relevance; the claimed invention cannot be considered novel or cannot be considered to involve an inventive step when the document is taken alone</p> <p>"Y" document of particular relevance; the claimed invention cannot be considered to involve an inventive step when the document is combined with one or more other such documents, such combination being obvious to a person skilled in the art.</p> <p>"&amp;" document member of the same patent family</p>
--	--

Date of the actual completion of the international search <b>14 October 2003</b>	Date of mailing of the international search report <b>30. 01. 2004</b>
---	---

Name and mailing address of the ISA European Patent Office, P.B. 5818 Patentlaan 2 NL - 2280 HV Rijswijk Tel. (+31-70) 340-2040, Tx. 31 651 epo nl, Fax: (+31-70) 340-3016	Authorized officer  - Krassow, H
--	--

INTERNATIONAL SEARCH REPORT

International Application No  
PCT/GB 03/02339

C.(Continuation) DOCUMENTS CONSIDERED TO BE RELEVANT		
Category *	Citation of document, with indication, where appropriate, of the relevant passages	Relevant to claim No.
A	EP 0 612 535 A (THEREX CORP) 31 August 1994 (1994-08-31) column 16, lines 17-23; figure 4 -----	1
A	WO 02/11703 A (UNIV NEW YORK) 14 February 2002 (2002-02-14) page 18, lines 3-13; figure 1 -----	1

# INTERNATIONAL SEARCH REPORT

International application No.  
PCT/GB 03/02339

## Box I Observations where certain claims were found unsearchable (Continuation of item 1 of first sheet)

This International Search Report has not been established in respect of certain claims under Article 17(2)(a) for the following reasons:

1.  Claims Nos.: 29, 32, 33  
because they relate to subject matter not required to be searched by this Authority, namely:  
Rule 39.1(iv) PCT - Method for treatment of the human or animal body by therapy
2.  Claims Nos.:  
because they relate to parts of the International Application that do not comply with the prescribed requirements to such an extent that no meaningful International Search can be carried out, specifically:
3.  Claims Nos.:  
because they are dependent claims and are not drafted in accordance with the second and third sentences of Rule 6.4(a).

## Box II Observations where unity of invention is lacking (Continuation of item 2 of first sheet)

This International Searching Authority found multiple inventions in this international application, as follows:

see additional sheet

1.  As all required additional search fees were timely paid by the applicant, this International Search Report covers all searchable claims.
2.  As all searchable claims could be searched without effort justifying an additional fee, this Authority did not invite payment of any additional fee.
3.  As only some of the required additional search fees were timely paid by the applicant, this International Search Report covers only those claims for which fees were paid, specifically claims Nos.:
4.  No required additional search fees were timely paid by the applicant. Consequently, this International Search Report is restricted to the invention first mentioned in the claims; it is covered by claims Nos.:  
1-14, 30

Remark on Protest

- The additional search fees were accompanied by the applicant's protest.  
 No protest accompanied the payment of additional search fees.



# INTERNATIONAL SEARCH REPORT

International Application No. PCT/GB 03/02339

FURTHER INFORMATION CONTINUED FROM PCT/ISA/ 210

Continuation of Box I.1

Claims Nos.: 29, 32, 33

Rule 39.1(iv) PCT - Method for treatment of the human or animal body by therapy

The applicant's attention is drawn to the fact that claims relating to inventions in respect of which no international search report has been established need not be the subject of an international preliminary examination (Rule 66.1(e) PCT). The applicant is advised that the EPO policy when acting as an International Preliminary Examining Authority is normally not to carry out a preliminary examination on matter which has not been searched. This is the case irrespective of whether or not the claims are amended following receipt of the search report or during any Chapter II procedure. If the application proceeds into the regional phase before the EPO, the applicant is reminded that a search may be carried out during examination before the EPO (see EPO Guideline C-VI, 8.5), should the problems which led to the Article 17(2) declaration be overcome.

## FURTHER INFORMATION CONTINUED FROM PCT/ISA/ 210

This International Searching Authority found multiple (groups of) inventions in this international application, as follows:

## 1. claims: 1-14, 30

Claims 1-14 essentially define an implantable drug delivery pump comprising

- 1) a metering rotor pump,
- 2) at least two lengths of tubes against which the rotor is moveable, and
- 3) an outlet port associated with the at least two length of tubes.

---

## 2. claims: 15-20, 28, 31

Claims 15-20, 28 and 31 essentially define a drug reservoir unit comprising

- 1) an outer housing, containing
- 2) a variable volume reservoir container, and
- 3) a port through which a drug may fill or exit from the reservoir leading to a separately located pump.

---

## 3. claims: 21-28, 31

Claims 21-28 and 31 essentially define a drug delivery system comprising

- 1) a drug reservoir unit,
- 2) a metering pump unit disposed remotely from the drug reservoir and arranged for pumping a drug from the reservoir to a delivery zone, and
- 3) a supply tube between the pump unit and the reservoir unit.

---

# INTERNATIONAL SEARCH REPORT

Information on patent family members

International Application No  
PCT/GB 03/02339

Patent document cited in search report	Publication date	Publication date	Patent family member(s)	Publication date
US 5752930	A	19-05-1998	NONE	
-----				
US 2002029018	A1	07-03-2002	AU 2172997 A	22-10-1997
			CA 2250159 A1	09-10-1997
			EP 0897307 A1	24-02-1999
			WO 9736623 A1	09-10-1997
-----				
US 3951147	A	20-04-1976	BE 838237 A1	28-05-1976
			CA 1054471 A1	15-05-1979
			CH 594420 A5	13-01-1978
			DE 2604113 A1	28-10-1976
			FR 2306712 A1	05-11-1976
			GB 1543330 A	04-04-1979
			IT 1057109 B	10-03-1982
			JP 1052638 C	30-06-1981
			JP 51117489 A	15-10-1976
			JP 55046195 B	21-11-1980
			NL 7601013 A ,B,	11-10-1976
			SE 424695 B	09-08-1982
			SE 7601158 A	08-10-1976
-----				
US 5957890	A	28-09-1999	EP 0998317 A1	10-05-2000
			WO 9856443 A1	17-12-1998
-----				
EP 0612535	A	31-08-1994	US 4978338 A	18-12-1990
			EP 0612535 A1	31-08-1994
			AT 115415 T	15-12-1994
			AU 628054 B2	10-09-1992
			AU 3535089 A	24-11-1989
			CA 1327927 C	22-03-1994
			DE 8916263 U1	23-05-1996
			DE 68920049 D1	26-01-1995
			DE 68920049 T2	20-07-1995
			DE 68928626 D1	30-04-1998
			DE 68928626 T2	16-07-1998
			EP 0446202 A1	18-09-1991
			WO 8910149 A2	02-11-1989
-----				
WO 0211703	A	14-02-2002	US 6497699 B1	24-12-2002
			AU 8119001 A	18-02-2002
			CA 2418070 A1	14-02-2002
			EP 1311245 A1	21-05-2003
			HU 0301698 A2	28-08-2003
			WO 0211703 A1	14-02-2002
-----				