



- (51) International Patent Classification:
A41D 13/08 (2006.01)
- (21) International Application Number:
PCT/US2012/047885
- (22) International Filing Date:
23 July 2012 (23.07.2012)
- (25) Filing Language: English
- (26) Publication Language: English
- (30) Priority Data:
61/513,582 30 July 2011 (30.07.2011) US
- (71) Applicant (for all designated States except US): PRINTS-GUARD CORPORATION [US/US]; 1933 Garden Drive, #303, Burlingame, California 94010 (US).
- (72) Inventors; and
- (75) Inventors/Applicants (for US only): KOFFI, Sylvain Y. [US/US]; 1933 Garden Drive, #303, Burlingame, California 94010 (US). HA, Monica [US/US]; 1933 Garden Drive, #303, Burlingame, California 94010 (US).

(74) Agents: MADDEN, Robert, B. et al.; Schwegman, Lundberg & Woessner, P.A., P.O. Box 2938, Minneapolis, Minnesota 55402 (US).

(81) Designated States (unless otherwise indicated, for every kind of national protection available): AE, AG, AL, AM, AO, AT, AU, AZ, BA, BB, BG, BH, BR, BW, BY, BZ, CA, CH, CL, CN, CO, CR, CU, CZ, DE, DK, DM, DO, DZ, EC, EE, EG, ES, FI, GB, GD, GE, GH, GM, GT, HN, HR, HU, ID, IL, IN, IS, JP, KE, KG, KM, KN, KP, KR, KZ, LA, LC, LK, LR, LS, LT, LU, LY, MA, MD, ME, MG, MK, MN, MW, MX, MY, MZ, NA, NG, NI, NO, NZ, OM, PE, PG, PH, PL, PT, QA, RO, RS, RU, RW, SC, SD, SE, SG, SK, SL, SM, ST, SV, SY, TH, TJ, TM, TN, TR, TT, TZ, UA, UG, US, UZ, VC, VN, ZA, ZM, ZW.

(84) Designated States (unless otherwise indicated, for every kind of regional protection available): ARIPO (BW, GH, GM, KE, LR, LS, MW, MZ, NA, RW, SD, SL, SZ, TZ, UG, ZM, ZW), Eurasian (AM, AZ, BY, KG, KZ, RU, TJ, TM), European (AL, AT, BE, BG, CH, CY, CZ, DE, DK, EE, ES, FI, FR, GB, GR, HR, HU, IE, IS, IT, LT, LU, LV, MC, MK, MT, NL, NO, PL, PT, RO, RS, SE, SI, SK, SM,

[Continued on next page]

(54) Title: FINGERTIP COVER AND METHODS OF MANUFACTURING AND DISPENSING SAME

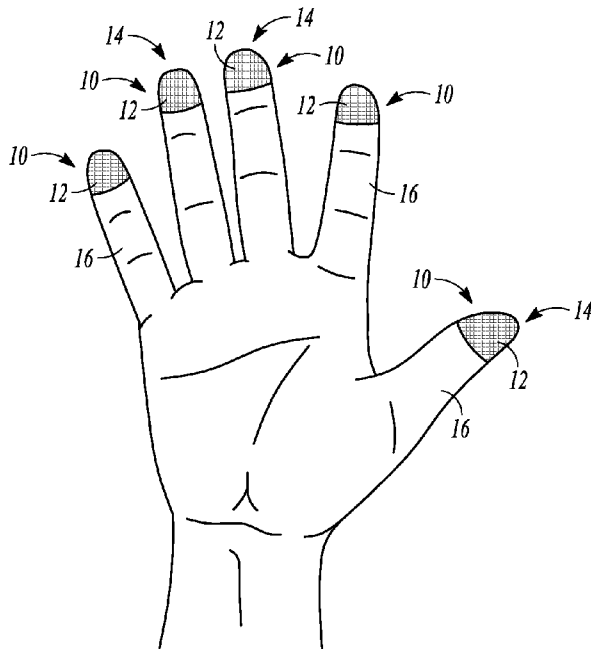

FIG. 1

(57) Abstract: Various embodiments of the present disclosure include a fingertip cover for preventing direct contact between a user's fingertip and a surface. The cover may be removably secured to a fingertip. In an example embodiment, the fingertip cover comprises a flexible substrate sized and configured to be placed on and conform to an area of the user's fingertip. At least a portion of the substrate is conductive to allow transmission of an electric charge from the fingertip to a surface, such as an electronic touch-screen. The cover allows operation of the touch-screen by the user while preventing direct contact between the fingertip cover and touch-screen. Methods of manufacturing and dispensing a cover are also disclosed.

TR), OAPI (BF, BJ, CF, CG, CI, CM, GA, GN, GQ, GW, ML, MR, NE, SN, TD, TG). **Published:**

— *without international search report and to be republished upon receipt of that report (Rule 48.2(g))*

FINGERTIP COVER AND METHODS OF MANUFACTURING AND
DISPENSING SAME

5

CLAIM OF PRIORITY

This patent application claims priority from U.S. Provisional Patent Application Serial No. 61/513,582, entitled "Fingertips Direct Contact Prevention System", filed July 30, 2011, which is incorporated herein by
10 reference in its entirety and made a part hereof.

BACKGROUND

It will be appreciated that finger or hand covering devices, such as
thimbles or gloves, have been in use for years. One significant problem with
15 conventional gloves and the like is that their insulating nature renders them
unsuitable for use with certain touch-screens. Moreover, some gloves are bulky
and hamper precision touches. Many hinder the manual dexterity, and lack the
preferred texture and gliding ability, required to effectively and easily operate
touch-screen surfaces. Some modern touch-screen surfaces are increasingly
20 provided on small portable electronic devices, for example. Another problem
with conventional hand or finger covers is that they are not conveniently put on
or taken off, nor are they conveniently worn by some individuals as they cover
the entire hand or finger and can become over-heated or sweaty. Another
problem with conventional hand or finger covers is that they do not wipe away
25 or clean a screen of fingerprints, finger oils, smudges and so forth from the
surface of such screens. While conventional covering devices may, in certain
circumstances, be suitable for the particular purpose they address, they are often
not conveniently disposable nor are adapted to isolate one or more fingertips in a
convenient or cost-effective manner.

SUMMARY

The present inventors have recognized, among other things, that a problem to be solved is that many people, when approaching touch-screens or similar devices, can be discouraged by the appearance of smudges and fingerprints on the screen. A dirty appearance, or the possibility of contacting germs, is discouraging. Users generally prefer to be isolated from such contaminants. Aesthetically, many users in any event dislike the visual appearance of smudges that can accumulate on a screen in use. A cleaner, more hygienic, environment at the screen surface is preferred.

The present subject matter can help provide a solution to this problem, such as by providing a fingertip cover for minimizing the appearance and creation of fingerprints or smudge deposits on an electronic touch-screen or other surface operated or contacted by the human fingertip. In another example embodiment, a fingertip cover is designed to clean such surfaces. Other solutions and example embodiments are described further below. In an example embodiment, a fingertip cover is designed for use with capacitive touch screens.

To better illustrate the bone fixation tool disclosed herein, a non-limiting list of numbered examples is provided here:

1. A fingertip cover comprising a substrate sized and configured to be placed on and conform to at least a portion of a fingertip of a user; wherein at least a portion of the substrate is conductive to allow the transmission of an electric charge from the fingertip portion to a contact surface.

2. The fingertip cover of Example 1, wherein the substrate is flexible.

3. The fingertip cover of Example 1 or Example 2, wherein at least a portion of the substrate can self-adhere to the fingertip portion thereby to hold the cover in place on the fingertip portion.

4. The fingertip cover of any one of Examples 1-3, further including an attachment surface to hold the cover in place on the fingertip portion.

5. The fingertip cover of any one of Examples 1-4, wherein the contact surface is a touch-screen and the transmission of an electric

charge from the fingertip portion to the contact surface allows operation of the touch-screen by the user.

6. The fingertip cover of any one of Examples 1-5, wherein the substrate includes electrically conductive material.

5 7. The fingertip cover of any one of Examples 1-6, wherein the substrate includes electrically non-conductive material on or in which an electrically conductive material is provided to allow transmission of an electric charge from the fingertip portion to the contact surface.

10 8. The fingertip cover of Example 7, wherein the electrically conductive material includes a metallic mesh or thread.

9. The fingertip cover of Example 4, wherein the attachment surface includes an adhesive.

10. The fingertip cover of Example 9, wherein the adhesive covers the entire surface of one side of the cover.

15 11. The fingertip cover of any one of Examples 1-10, further comprising a release tab.

12. The fingertip cover of Example 9, wherein the adhesive includes a hypoallergenic substance or material.

20 13. The fingertip cover of any one of Examples 1-12, wherein one or more notches are provided around the periphery of the substrate.

14. The fingertip cover of any one of Examples 1-13, wherein the substrate is provided with a surface cleaning agent.

15. The fingertip cover of any one of Examples 1-14, wherein the substrate includes biodegradable material.

25 16. The fingertip cover of Example 1, wherein the substrate includes a nonwoven material.

17. The fingertip cover of any one of Examples 1-16, wherein the substrate includes a breathable material.

30 18. The fingertip cover of any one of Examples 1-17, wherein the thickness of at least a portion of the substrate does not exceed 0.020 of an inch.

19. The fingertip cover of any one of Examples 1-18, further comprising a releasable backing strip on which the cover is provided.

20. The fingertip cover of Example 19, wherein the backing strip is a business card or a credit card.

21. The fingertip cover of any one of Examples 1-20, wherein the area of the cover allows placement of the cover only to an area of the fingertip substantially facing, or contacting, the contact surface when the cover is in place.

22. A kit or set including at least one fingertip cover, the or each cover comprising a flexible substrate sized and configured to be placed on and conform to at least a portion of a fingertip of a user; and a releasable backing strip on which the at least one cover is provided.

23. The kit or set of Example 22, wherein, for the or each cover, at least a portion of the substrate is conductive to allow the transmission of an electric charge from the fingertip portion to a contact surface.

24. The kit or set of Example 22 or Example 23, wherein the number of fingertip covers in the kit or set is between 5 and 12.

25. The kit or set of any one of Examples 22-24, wherein at least one fingertip cover in the kit or set is of different size than at least one other fingertip cover in the kit or set.

26. A method of manufacturing or dispensing fingertip covers comprising providing at least one fingertip cover, the at least one cover comprising a flexible substrate sized and configured to be placed on and conform to a portion of a fingertip of a user; providing at least one backing strip; and securing the at least one cover on the backing strip in releasable manner so that a user can release the at least one cover from the backing strip for placement on a portion of a fingertip of the user.

27. The method of Example 26, wherein at least a portion of the substrate of the at least one cover is conductive to allow the transmission of an electric charge from the fingertip portion to a contact surface.

28. The method of Example 26 or Example 27, further comprising providing adhesive on the at least one cover to secure a respective cover, once released from the backing strip, to the fingertip portion.

29. The method of Example 28, wherein the adhesive on the at least one cover secures the at least one cover in releasable manner to the

backing strip, and allows subsequent securement of the at least one cover to the backing strip after initial release.

30. The method of any one of Examples 26-29, wherein the backing strip is an elongate backing strip carrying at least one series of fingertip covers along its length.

31. The method of Example 30, wherein the elongate strip is provided in a rolled configuration.

32. The method of Example 31, further comprising providing the rolled strip in a dispenser.

33. The method of Example 32, wherein the dispenser defines a lip which can peel a cover off the backing strip as the backing strip is withdrawn from the dispenser.

These and other examples and features of the present tool, kit, and method will be set forth in part in the following Detailed Description. This Summary is intended to provide non-limiting examples of the present subject matter. It is not intended to provide an exclusive or exhaustive explanation. The Detailed Description is included to provide further information about the present tool, kit, and method.

BRIEF DESCRIPTION OF DRAWINGS

Some embodiments are illustrated by way of example and not limitation in the figures of the accompanying drawings in which:

FIG. 1 is an underside pictorial view of five fingertip covers, each fitted to a user's fingertips, according to an example embodiment.

FIG. 2 is a front pictorial view of a fingertip cover fitted to a user's index fingertip, according to an example embodiment.

FIGS. 3A-3B are pictorial views of a fingertip covers, according to example embodiments.

FIG. 4 is a pictorial view of a set of fingertip covers, according to an example embodiment.

FIG. 5 is a pictorial view of a set of fingertip covers, according to another example embodiment.

FIG. 6 shows a flow chart for a method of dispensing fingertip covers, according to an example embodiment.

FIGS. 7A-7B is a pictorial view of a set of fingertip covers, according to another example embodiment.

FIG. 8 is a pictorial view of a set of fingertip covers, according to another example embodiment.

5 **FIGS. 9A-9E** show aspects of a set of fingertip covers, according to an example embodiment.

FIG. 10 is a pictorial view of a set of fingertip covers, according to another example embodiment.

10 DETAILED DESCRIPTION

Turning now to the drawings, similar reference characters denote similar elements throughout the several views. **FIGS. 1 and 2** of the attached figures illustrate an example embodiment of a fingertip cover, shown generally at **10**. Each cover **10** comprises a substrate **12** which may be affixed over an area of a user's fingertips **14** in the manner shown and as described further below. The cover is conveniently secured in removable manner to the fingertip and prevents direct contact between the user's fingertip and a surface. As is also described further below, the substrate may in various embodiments include or be constituted by various materials or substances.

20 In this specification, the term "fingertip" is intended to include a thumb tip, and the term refers generally to the rounded portion at the end of person's finger (or thumb) **16**.

FIGS. 3A-3B illustrate example embodiments of a fingertip cover **10**. As is described in further detail below, the substrate **12** of the cover **10** may be flexible and provided in various sizes to accommodate and cover many sizes of human fingertip. In the embodiment shown in **FIGS. 3A-3B**, the substrate **12** of the cover **10** comprises a resilient, flexible semi-rigid material. The cover **10** is shaped in a concave form so as to conform tightly to the round shape of a human fingertip **14**. The curvature of the concave fingertip cover **10** shown in **FIGS. 3A-3B** may in various embodiments be made or provided in a tighter form or profile than the curvature of a human fingertip. This allows the resilient nature of the substrate material, when deformed to fit a fingertip, to generate inwardly directed forces such that the cover **10** "clasps" the fingertip to prevent the cover from falling off the fingertip in use.

In other embodiments of the cover, the shape of the cover may allow it to be secured to a fingertip in use. For example, the substrate **12** may be provided in generally conical form to substantially enclose the entire fingertip. In some embodiments, the substrate may be substantially inflexible and may comprise a
5 metallic or hard plastics material, for example.

In various other embodiments, the material of the substrate **12** may be of such a nature that it inherently clings to the skin of a human fingertip, for example in the manner of a cling- or shrink- wrap material. The cover **10** may in other examples frictionally engage a human fingertip to remain secured in place.
10 One side of the substrate may be provided in rougher form than the other, with the rougher side being adapted to engage a fingertip in a secure manner. The other side of the substrate cover may be less rough to slide easily over a surface. In some embodiments, the less rough side may be very smooth, or comprise or have a friction-reducing material or non-abrasive agent applied to it, such as a
15 wax or silicon. The reduction of friction augments the ability of the cover to glide smoothly over a surface.

An alternate version of the cover may envelop the fingertip. A top side of the cover may cover a user's finger nail and, with the use of adhesive for example, hold the cover in place. The rougher and more rigid topography of a
20 user's finger nail, as opposed to skin, may increase the tenacity of the adhesive's engagement. A bottom or "working" side of the cover may be situated on the other side of the fingertip for use by the user on touch surfaces.

Viewed conceptually, in some of the example embodiments and methods described above, the fingertip cover **10** "self-adheres" to a human fingertip. The
25 cover **10** does not require (but nevertheless may comprise) separate attachment means to secure it to a fingertip.

Reference is now made to **FIG. 4**. This figure shows a cover **10** that can be provided individually in kit form, or in a set **40**, as shown. In the illustrated view, the set of covers are connected together. In other embodiments, a plurality
30 of individual covers may be provided. Each cover **10** in the set includes a flexible substrate **12** sized and configured to be placed over an area of the user's fingertip. The substrate **12** is initially planar but is deformable to conform to the rounded shape of a user's fingertip.

As shown in **FIG. 4**, a series of covers **10** may be provided along the length of an elongate backing strip **20**. Each cover **10** may be peeled off the backing strip for attachment to a user's fingertip. In this view, one series of covers **10** is provided along the length of the backing strip, but in other
5 embodiments, such as shown in **FIG. 5**, one or more series of fingertip covers may be provided.

In some embodiments, a cover **10** may have a generally semi-circular shape in plan outline. As shown in **FIGS. 4** and **5**, the shape of the cover is defined by a generally curved edge **24** and a straight edge **26**. When fitting a
10 cover **10** to a fingertip **14**, the straight edge **26** may be wrapped around a base or proximal portion of the fingertip, with the curved edge extending around a distal or peripheral portion of the fingertip at an extremity of the finger. The cover **10** may be placed on a fingertip **14** so that at least a portion of the cover substrate **12** is interposed in use between the fingertip and a surface. One or more notches **30**
15 may be provided around the periphery of the cover **10** to facilitate fitting the substrate to a user's fingertip without creating bumps or wrinkles.

The straight edge **26** of the cover may be about one inch in length with the other dimensions of the cover sized accordingly. As shown in **FIG. 5**, a set of covers **10** may include covers **10** of varying sizes. The number of fingertip
20 covers **10** in a set may be 5 or more. For example, a set of ten covers allows convenient attachment of a cover to each finger (and the two thumbs) of a user and is beneficial to some individual using a keyboard. At least one cover in the set may be of different size than at least one other cover in the set to match the varying sizes of the fingers and thumb on a user's hand. It will be appreciated
25 that the dimensions of the cover **10** may be optimized to suit different sizes of fingertips that may occur in various demographic populations, or genders.

The backing strip **20** may include a waxed material to facilitate removal of each cover from the backing strip. The backing strip **20** may allow a cover **10** to be re-secured to the backing strip after initial release. In some embodiments,
30 perforations **22** are provided in the backing strip to allow individual portions of the backing strip to be torn off. The perforations **22** may for example extend transversely across the backing strip in a linear or curved outline, as shown in **FIG. 4**. A series of interconnected covers may, in some embodiments, not have a

backing strip. One cover may be joined to another by a frangible line, for example.

Optionally, as show in **FIG. 5**, a set of covers **10** may conveniently be provided on a backing strip **20** in the form a credit card or business card, for example. The appearance or convenience of this embodiment may create a favorable or memorable impression in the mind of a person presented with such a business or credit card, and may enhance development of personal or business relationships accordingly. The backing strip, credit or business card **20** may conveniently be sized to fit in standard clothing pockets. The set may be provided in a plastic sleeve **32**.

The substrate **12** of a cover **10** may be shaped or be deformable to conform and self-adhere to a user's fingertip, as described above. The cover **10** may in some embodiments be secured to a fingertip by other attachment methods. In an example embodiment, attachment means may be provided in the form of an adhesive or glue applied to area of the substrate **12** intended to be secured to a fingertip in use. The substrate **12** can be secured to the fingertip using a non-residue glue so that the cover can be removed from a fingertip without leaving trace elements or sticky patches of glue on the fingertip. In various embodiments, the adhesive means can include a hypoallergenic substance or material. Advantageously, the cover **10** can be worn from a few minutes to several hours without skin irritation and discomfort. Other types of adhesive or glue can be used, as appropriate.

In another embodiment, the substrate **12** may be secured to the fingertip by enveloping the fingertip in an overlapping manner so to stick to itself. In other embodiments, the substrate **12** may wrap around a portion, or all, of the fingertip and utilize small elastic or rubber bands, or "hook-and-loop" material or small magnets, for example at an edge of the cover, to hold the cover **10** in place. The adhesive or glue may cover an entire surface of the substrate, or in other embodiments, the disposition of the adhesive may allow at least a portion of the substrate to remain unattached to the user's fingertip. The unattached portion may define a release tab to facilitate removal of the cover from the fingertip after use. The cover may include a supplementary small strip area, or release tab. The release tab may be provided at one edge of the cover and carry

no adhesive to allow, when pulled, an easier removal of the cover from the fingertip.

In various embodiments, the substrate **12** of the fingertip cover **10** may include a cloth-like material, paper or paper-like material, a film material, or
5 other flexible material. Flexible materials may include nonwoven materials, such as a spun-lace, a melt-blown, or a spun-bond material. The substrate material may be needle punched or perforated in some manner. The material may in some
10 embodiments include a breathable or biodegradable material. The properties of the substrate material may be selected so that the cover does not leak adhesive or glue in normal use. The substrate may also be provided with a surface cleaning
agent, or may comprise or include a material that inherently acts as a cleaning material. The substrate may for example be made of tissue paper or a similar material that makes the cover a natural surface wiper or cleaner.

Some embodiments of the fingertip cover **10** may conveniently be used
15 with an electronic capacitive touch-screen. As the human body is an electrical conductor, touching the surface of such a screen results in a distortion of the screen's electrostatic field, measurable as a change in capacitance. An electric charge is allowed to pass from fingertip to screen. Conventional devices that may cover a fingertip hinder or prevent the transmission of such a charge.
20 Capacitive touch-screens requiring transmission of an electric charge are therefore rendered substantially inoperable, or at least difficult to operate with conventional devices.

In some embodiments, at least a portion of the substrate **12** of the cover
25 **10** is conductive to allow transmission of an electric charge from the fingertip to a touch-screen or other surface. Typically, the conductive portion of the substrate will in use be interposed between the user's fingertip and the surface as the screen is operated. The conductive portion may be provided in any convenient area of the substrate, for example as shown by the circular patch at **18** in **FIG. 4**. Other areas or shapes of conductive portions are possible. This screen-facing
30 location facilitates convenient placement of the conductive portion by a user on a touch-screen. In some embodiments, the entire area of the substrate **12** may be conductive so that no matter how or where the cover is positioned on a fingertip, electrical conductivity is provided.

In various embodiments, the substrate **12** may include electrically conductive material. In some embodiments, the substrate may include electrically non-conductive material on or in which an electrically conductive material is provided to allow transmission of an electric charge between the user's fingertip and the surface. The electrically conductive material may include a metallic mesh, thread or foil embedded in or on the material of the substrate. In some embodiments, the thickness of at least a portion of the substrate does not exceed 0.020 of an inch. The thin nature of this material, whether inherently electrically conductive or not, provides the cover with sufficient conductivity to allow the passing of a charge between fingertip and screen.

Some embodiments of the present inventive subject matter include methods for dispensing fingertip covers. One such embodiment is illustrated generally in **FIG. 6**. Further embodiments or variations are described below. In an example embodiment, a method **600** of dispensing fingertip covers comprises: at **602**, providing at least one fingertip cover, the (or each) cover comprising a flexible substrate sized and configured to be placed on and conform to at least one of the user's fingertips; at **604**, providing the at least one cover on a backing strip; and at **606**, securing or providing the at least one cover on the backing strip in releasable manner so that a user can release the at least one cover from the backing strip for placement on at least one of the user's fingertips. At least a portion of the substrate of the at least one cover may allow transmission of an electric charge from the fingertip to the surface.

The method may further comprise providing adhesive means on at least one cover to secure the cover to a user's fingertip once released from the backing strip. The adhesive means on the at least one cover may secure the respective cover in releasable manner to the backing strip, and allow subsequent securement of the cover to the backing strip after initial release.

The backing strip may be an elongate backing strip carrying at least one series of said fingertip covers along its length. In an example embodiment, the elongate strip may be provided in a rolled configuration. The rolled backing strip may be provided in, or capable of being installed in, a dispenser. The dispenser may define a lip which can peel a cover off the backing strip as the backing strip is withdrawn from the dispenser. The rolls can conveniently be loaded in manual and/or automatic dispensers.

In another example embodiment, the cover may carry adhesive only at the edges of the cover, but not in a central area. For example, with reference to **FIGS. 7A** and **7B**, a set **70** of covers **10** is provided. A peripheral portion **34** of each cover has adhesive applied to it, while a central portion **36** has no adhesive applied to it. The set of six covers shown is provided on a backing strip in the form of a business card **38**. The length of the business card is approximately 3.370 inches, and the width approximately 2.125 inches. Two sizes of cover **10** are provided in this example embodiment, but other sizes are possible. In **FIG. 7B**, the width across the straight edge of the larger cover is approximately 1.00 inch, while the height from straight edge to top of curved apex is approximately 0.80 inches. The radius of curvature **40** is approximately 0.50 inches, and the position of the radius center is approximately 0.30 inches above the straight edge **26** of the cover **10**. Corresponding approximate dimensions in inches for the smaller cover are 0.80, 0.60, 0.40, and 0.20, respectively.

Another example embodiment of a set of covers **80** is shown in **FIG. 8** of the accompanying drawings. A set of six covers is provided on a backing strip **20** in the form of a business card business card **82**. The card is approximately 3.5 inches in length, and 2.0 inches in width. Each cover has three notches **30** around the curved periphery of the cover. The notches **30** shown in the accompanying drawings facilitate a close conformance fit and wrinkle-free fitment of the cover **10** to a fingertip. Three sizes of cover **10** are shown. Perforations or slits **86** may be provided to facilitate tearing off the backing strip and releasing a cover **10**, as needed. The “medium” and “small” sizes of cover illustrated in **FIG. 8** may be of the same approximate size as the two sizes of cover described above with reference to **FIGS. 7A** and **7B**. The “large” size of cover **10** in **FIG. 8** may have corresponding approximate dimensions in inches of 1.20, 0.90, 0.60, and 0.30, respectively.

Reference is now made to **FIGS. 9A-9E** of the accompanying drawings. Here, a set **90** of eight covers **10** is shown in **FIG. 9B**. Three sizes of cover (small, medium and large) are provided. The set **90** includes two large, two small, and four medium sizes of cover, in two series extending along the backing strip **20**, as shown. The backing strip **20** may be a credit card or a business card, but other configurations are possible in any of the embodiments described herein. Here, the example backing strip **20** is provided in the form of a credit or

business card, having a length of 3.5 inches and a width of 2.0 inches, approximately. The approximate dimensions **H** (height) and **W** (width) of the three sizes of cover shown in **FIG. 9A** are 1.0, 0.8, 0.7 and 1.0, 0.75, 0.65, respectively. With reference to **FIG. 9C**, the approximate dimensions **H** and **W** of a notch 30 in a cover **10** are 5 mm and 2 mm, respectively.

Each cover **10** in **FIGS. 9A-9E** will be seen to comprise a tab **92**. With reference in particular to **FIG. 9E**, each tab **92** is folded at the imaginary line **96-96**. One part **92B** of the tab **92** is folded in the direction of arrow **94** about the imaginary line **96-96** to lie on top of another part **92A** of the tab. Part **92A** is of complementary size and shape in mirror image, as shown. The interior sides of a folded tab **92** can be held clear of any adhesive provided to secure a respective cover **10** in releasable manner to the backing strip **20**, even if adhesive is applied to the outer surface of part **92A** of the tab lying on the backing strip **20**. The unadhered tab part **92B** can be unfolded by a user to define a convenient pull tab. After release of the cover **10** from the backing strip, the tab **92** may, in some example embodiments, be releasable from the cover **10**.

In **FIG. 10** of the accompanying drawings, a set of covers **100** is shown. Here an elongate series of covers **10** (only two are shown) is provided on an inter-connected set of backing strip portions **20A** and **20B**, as shown. The backing strip portions are connected to each other by frangible connections **102** so that they can be separated by a user. An oval hole **104** can be provided, as well as a cut or slit **106**, to facilitate removal of a backing strip portion **20A** or **20B** from a cover **10**.

In some example embodiments, the cover **10** may be provided with metallic or other conductive material to allow the electric charges present at the tip of the human finger to reach the touch surface of a screen. This allows a cover composed of otherwise electrically insulating material to become conductive of electricity.

The cover is conveniently disposable, and is generally expected to be used one time only and be discarded thereafter. Alternatively, the cover may be reattached to a backing strip or other convenient surface for re-use. The substrate may be constructed from a durable material that can be used for extended periods without significant change in the properties of the cover.

In an example embodiment, the cover may be used as a cleaning device. It allows a user to clean personal devices. In more public settings, such as airport kiosks, museum touch-screen displays, self-checkout stations, ATM's and the like, the cover may be used to clean the screen as the cover is being used. An
5 antiseptic or cleaning agent may be provided in the cover.

The backing strip may comprise a part-cut or perforated backing or wax paper. In an example embodiment, a fingertip cover is disposed across a cut or perforation in the backing strip so that when the backing strip is torn along the cut or perforation, a portion of the underside of the cover is exposed. The
10 exposed portion of the cover may be gripped by a user to facilitate peeling the rest of the cover off the backing strip.

The cover is in some embodiments able to glide easily and smoothly on touch-screens such as those found on the Apple iPad, or other computer tablets.

The cover may in some embodiments work on various types of touch-
15 screens, including: resistive, surface acoustic wave, capacitive, surface capacitance, projected capacitance, mutual capacitance, self-capacitance, infrared, optical imaging, dispersive signal technology and acoustic pulse recognition screens.

The fingertip cover may also optionally be used to handle delicate objects
20 (for example glass and jewelry) on which fingertip deposits are unwanted.

The cover **10** minimizes in use the deposition on or pick-up from surfaces of fingertip deposits, smudge, and other contaminants. Contact with germs, bacteria, viruses and the like can also be inhibited. In contagious outbreaks, or other emergency situations for example, the ability to reduce the
25 rapid spread of disease can be crucial. Covers of the type described herein can be used with great facility in various prophylactic applications. In some applications, covers of the kind described herein could be issued by the Center for Disease Control (CDC), or other health (World Health Organization) or government authority as appropriate to restrain the spread of disease.

The cover **10** can be used in many other applications or environments.
30 Potential users can include people using touch-screens at airports, banks, supermarkets, kiosks, elevator buttons which require the use of or include touch surfaces. The cover **10** described and claimed herein can provide an inexpensive and disposable fingertip protection and covering device. In other applications for

example, the hygienic use of public toilet seats can be facilitated. A small dispenser of fingertip covers can also be presented on a vehicle dashboard or console, for example, and particularly provided conveniently adjacent any touch-screen or control surface in the vehicle.

5

NON-LIMITING EMBODIMENTS

While the invention has been described with reference to specific embodiments, it will be understood by those skilled in the art that various changes may be made and equivalents may be substituted for the elements thereof without departing from the true spirit and scope of the invention. In addition, modifications may be made without departing from the essential teachings of the invention. Moreover, each of the non-limiting examples described herein can stand on its own, or can be combined in various permutations or combinations with one or more of the other examples.

15 The above detailed description includes references to the accompanying drawings, which form a part of the detailed description. The drawings show, by way of illustration, specific embodiments in which the invention can be practiced. These embodiments are also referred to herein as “examples.” Such examples can include elements in addition to those shown or described.

20 However, the present inventors also contemplate examples in which only those elements shown or described are provided. Moreover, the present inventors also contemplate examples using any combination or permutation of those elements shown or described (or one or more aspects thereof), either with respect to a particular example (or one or more aspects thereof), or with respect to other

25 examples (or one or more aspects thereof) shown or described herein.

In the event of inconsistent usages between this document and any documents so incorporated by reference, the usage in this document controls.

In this document, the terms “a” or “an” are used, as is common in patent documents, to include one or more than one, independent of any other instances or usages of “at least one” or “one or more.” In this document, the term “or” is used to refer to a nonexclusive or, such that “A or B” includes “A but not B,” “B but not A,” and “A and B,” unless otherwise indicated. In this document, the terms “including” and “in which” are used as the plain-English equivalents of the respective terms “comprising” and “wherein.” Also, in the following claims,

the terms “including” and “comprising” are open-ended, that is, a system, device, article, composition, formulation, or process that includes elements in addition to those listed after such a term in a claim are still deemed to fall within the scope of that claim. Moreover, in the following claims, the terms “first,”
5 “second,” and “third,” etc. are used merely as labels, and are not intended to impose numerical requirements on their objects.

The above description is intended to be illustrative, and not restrictive. For example, the above-described examples (or one or more aspects thereof) may be used in combination with each other. Other embodiments can be used,
10 such as by one of ordinary skill in the art upon reviewing the above description. The Abstract is provided to comply with 37 C.F.R. §1.72(b), to allow the reader to quickly ascertain the nature of the technical disclosure. It is submitted with the understanding that it will not be used to interpret or limit the scope or meaning of the claims. Also, in the above Detailed Description, various features
15 may be grouped together to streamline the disclosure. This should not be interpreted as intending that an unclaimed disclosed feature is essential to any claim. Rather, inventive subject matter may lie in less than all features of a particular disclosed embodiment. Thus, the following claims are hereby incorporated into the Detailed Description as examples or embodiments, with
20 each claim standing on its own as a separate embodiment, and it is contemplated that such embodiments can be combined with each other in various combinations or permutations. The scope of the invention should be determined with reference to the appended claims, along with the full scope of equivalents to which such claims are entitled.

CLAIMS

What is claimed is:

5

1. A fingertip cover comprising:

a substrate sized and configured to be placed on and conform to at least a portion of a fingertip of a user;

10 wherein at least a portion of the substrate is conductive to allow the transmission of an electric charge from the fingertip portion to a contact surface.

2. The fingertip cover of claim 1, wherein the substrate is flexible.

15 3. The fingertip cover of claim 1, wherein at least a portion of the substrate can self-adhere to the fingertip portion thereby to hold the cover in place on the fingertip portion.

4. The fingertip cover of claim 1, further including an attachment surface to hold the cover in place on the fingertip portion.

20

5. The fingertip cover of claim 1, wherein the contact surface is a touch-screen and the transmission of an electric charge from the fingertip portion to the contact surface allows operation of the touch-screen by the user.

25 6. The fingertip cover of claim 1, wherein the substrate includes electrically conductive material.

7. The fingertip cover of claim 1, wherein the substrate includes electrically non-conductive material on or in which an electrically conductive material is provided to allow transmission of an electric charge from the fingertip portion to the contact surface.
- 5
8. The fingertip cover of claim 7, wherein the electrically conductive material includes a metallic mesh or thread.
9. The fingertip cover of claim 4, wherein the attachment surface includes an adhesive.
- 10
10. The fingertip cover of claim 9, wherein the adhesive covers the entire surface of one side of the cover.
- 15
11. The fingertip cover of claim 1, further comprising a release tab.
12. The fingertip cover of claim 9, wherein the adhesive includes a hypoallergenic substance or material.
- 20
13. The fingertip cover of claim 1, wherein one or more notches are provided around the periphery of the substrate.
14. The fingertip cover of claim 1, wherein the substrate is provided with a surface cleaning agent.
- 25
15. The fingertip cover of claim 1, wherein the substrate includes biodegradable material.

16. The fingertip cover of claim 1, wherein the substrate includes a nonwoven material.
17. The fingertip cover of claim 1, wherein the substrate includes a breathable
5 material.
18. The fingertip cover of claim 1, wherein the thickness of at least a portion of the substrate does not exceed 0.020 of an inch.
- 10 19. The fingertip cover of claim 1, further comprising a releasable backing strip on which the cover is provided.
20. The fingertip cover of claim 19, wherein the backing strip is a business card or a credit card.
15
21. The fingertip cover of claim 1, wherein the area of the cover allows placement of the cover only to an area of the fingertip substantially facing, or contacting, the contact surface when the cover is in place.
- 20 22. A kit or set including:

at least one fingertip cover, the or each cover comprising a flexible substrate sized and configured to be placed on and conform to at least a portion of a fingertip of a user; and
25

a releasable backing strip on which the at least one cover is provided.
23. The kit or set of claim 22, wherein, for the or each cover, at least a portion of the substrate is conductive to allow the transmission of an electric charge from
30 the fingertip portion to a contact surface.
24. The kit or set of claim 22, wherein the number of fingertip covers in the kit or set is between 5 and 12.

25. The kit or set of claim 22, wherein at least one fingertip cover in the kit or set is of different size than at least one other fingertip cover in the kit or set.

26. A method of manufacturing or dispensing fingertip covers comprising:

5

providing at least one fingertip cover, the at least one cover comprising a flexible substrate sized and configured to be placed on and conform to a portion of a fingertip of a user;

10

providing at least one backing strip; and

securing the at least one cover on the backing strip in releasable manner so that a user can release the at least one cover from the backing strip for placement on a portion of a fingertip of the user.

15

27. The method of claim 26, wherein at least a portion of the substrate of the at least one cover is conductive to allow the transmission of an electric charge from the fingertip portion to a contact surface.

20

28. The method of claim 26, further comprising providing adhesive on the at least one cover to secure a respective cover, once released from the backing strip, to the fingertip portion.

25

29. The method of claim 28, wherein the adhesive on the at least one cover secures the at least one cover in releasable manner to the backing strip, and allows subsequent securement of the at least one cover to the backing strip after initial release.

30

30. The method of claim 26, wherein the backing strip is an elongate backing strip carrying at least one series of fingertip covers along its length.

31. The method of claim 30, wherein the elongate strip is provided in a rolled configuration.

32. The method of claim 31, further comprising providing the rolled strip in a dispenser.

33. The method of claim 32, wherein the dispenser defines a lip which can peel a
5 cover off the backing strip as the backing strip is withdrawn from the dispenser.

1/8

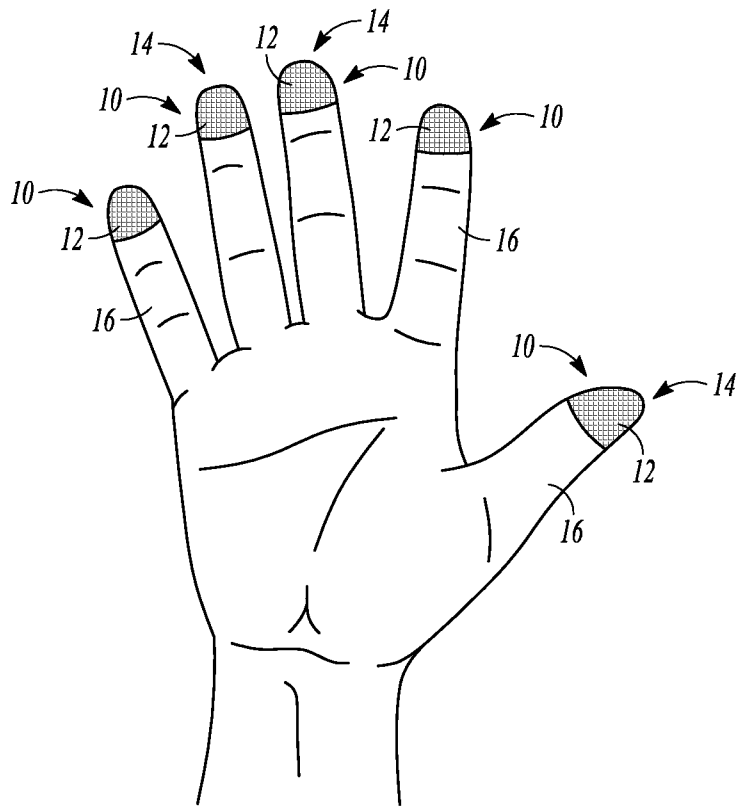

FIG. 1

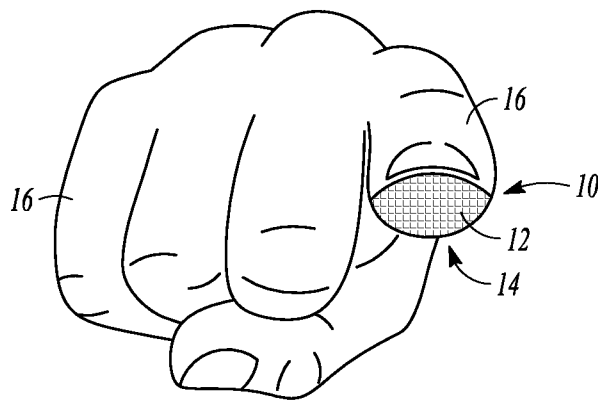

FIG. 2

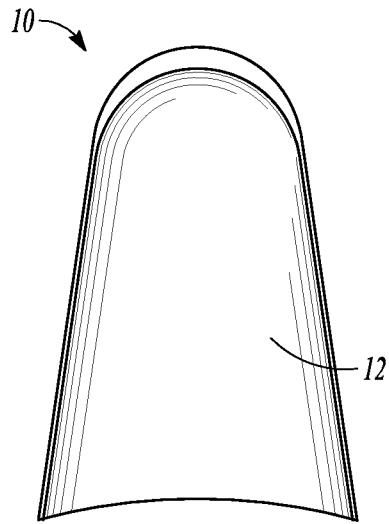

FIG. 3A

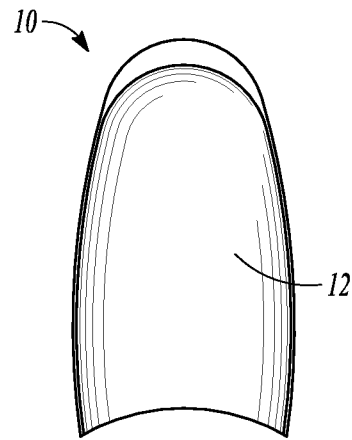

FIG. 3B

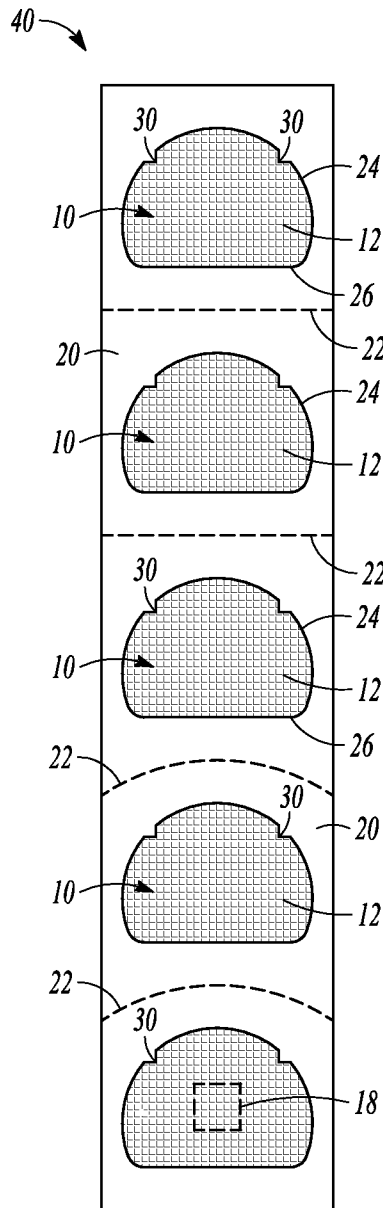

FIG. 4

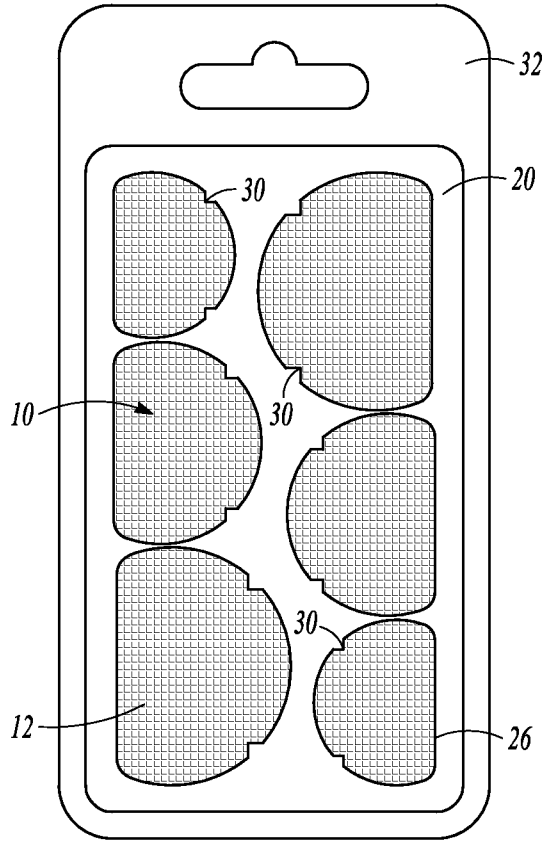

FIG. 5

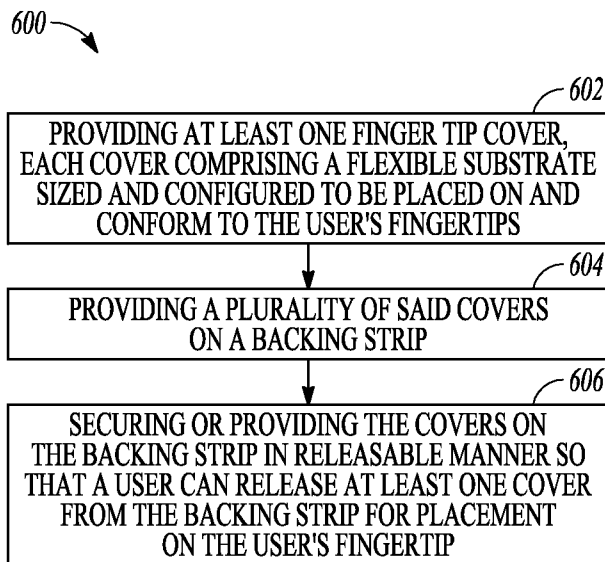

FIG. 6

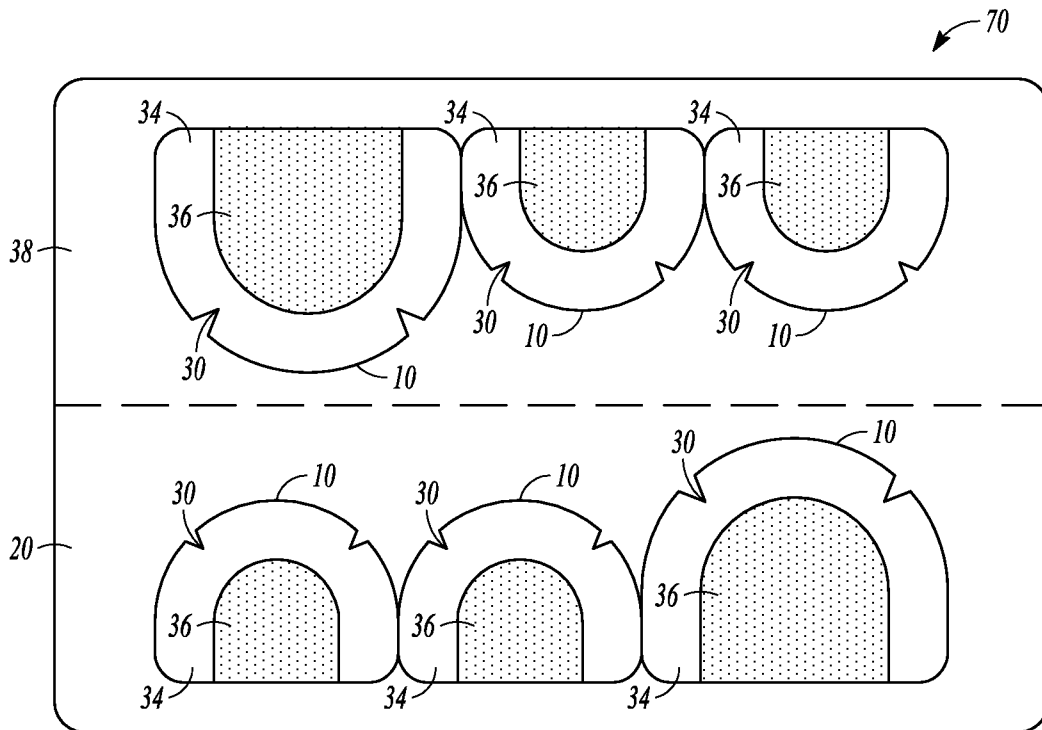

FIG. 7A

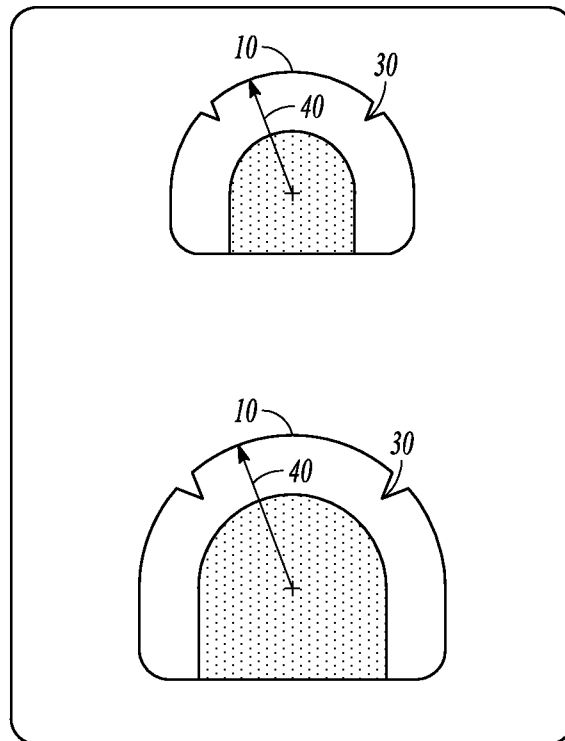

FIG. 7B

6/8

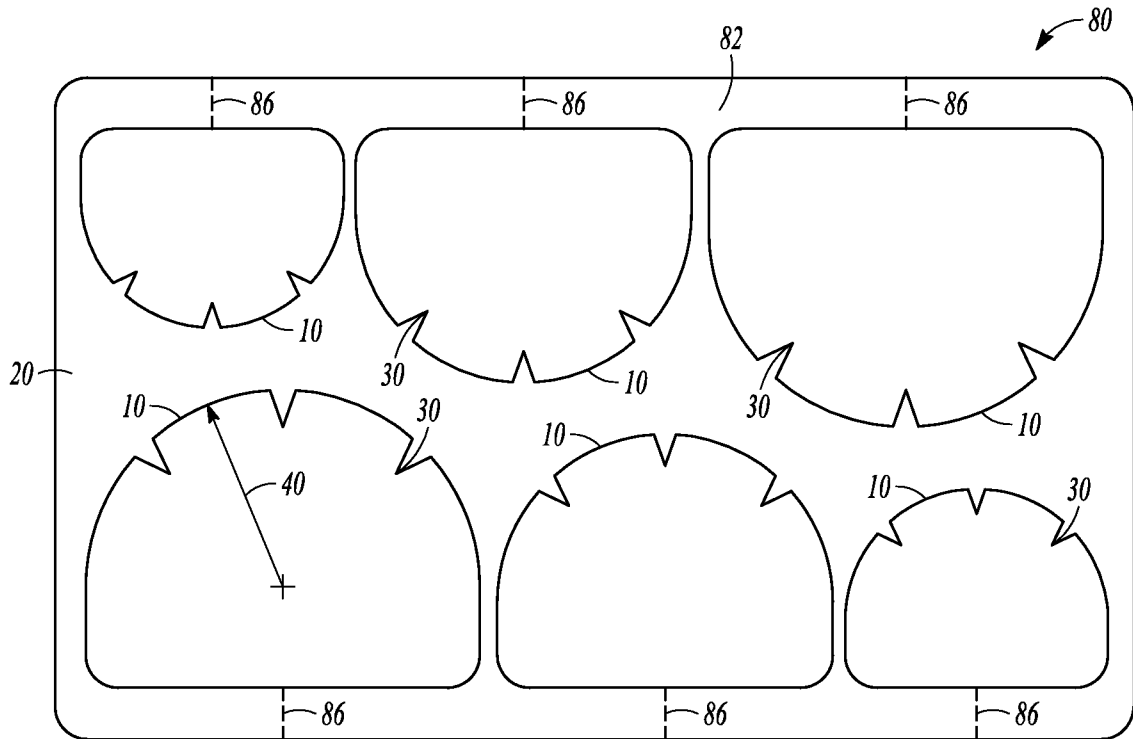

FIG. 8

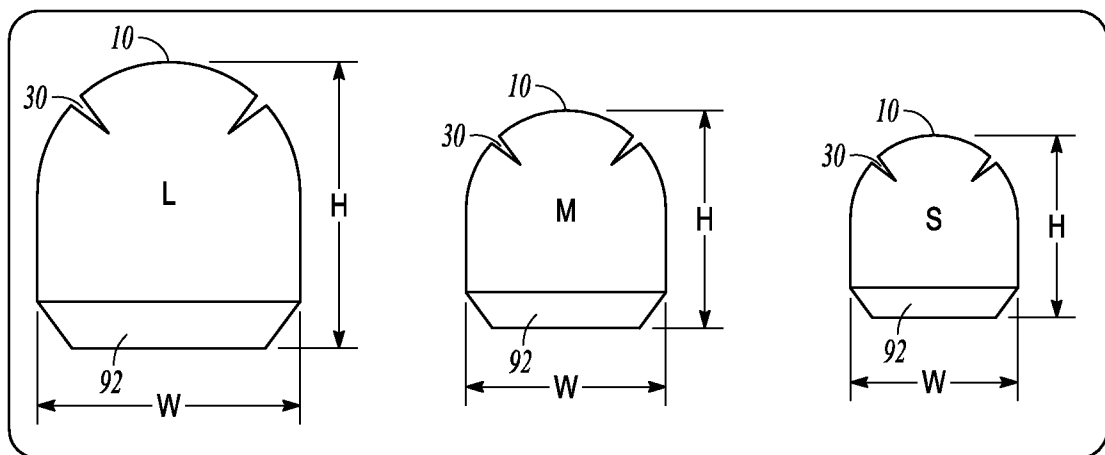

FIG. 9A

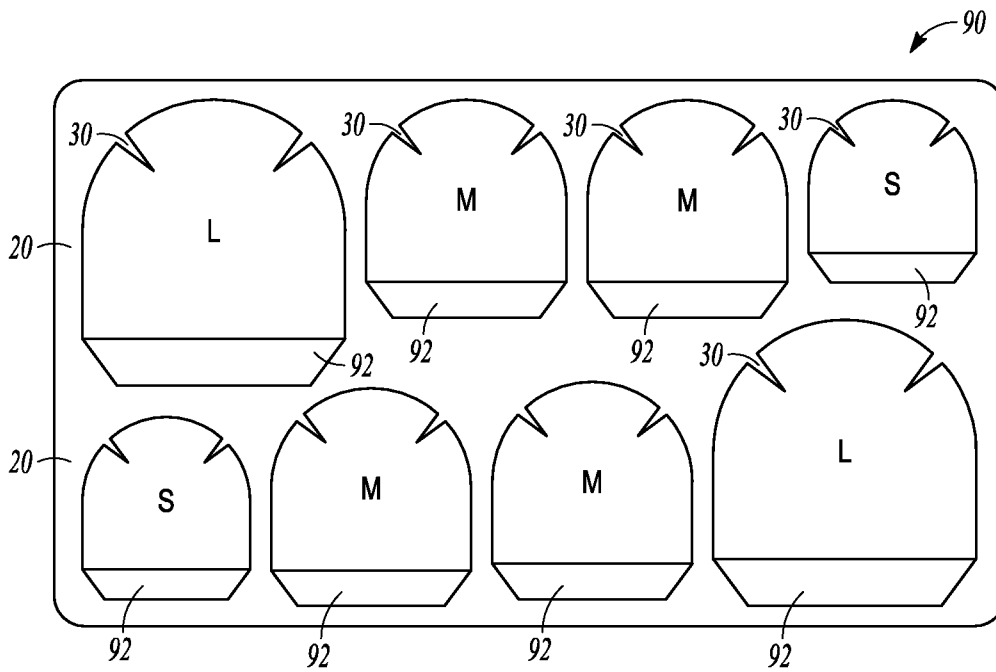

FIG. 9B

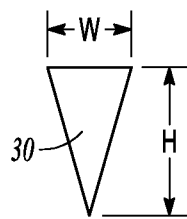

FIG. 9C

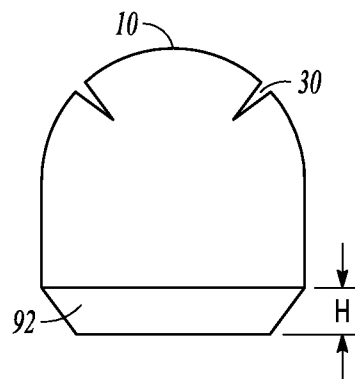

FIG. 9D

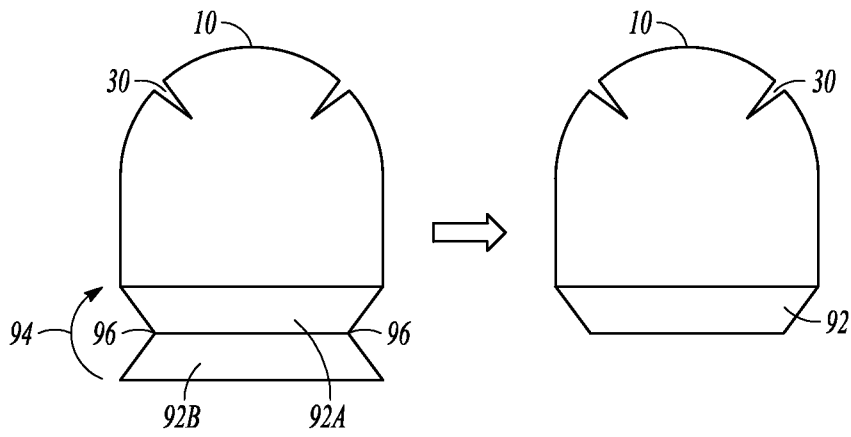

FIG. 9E

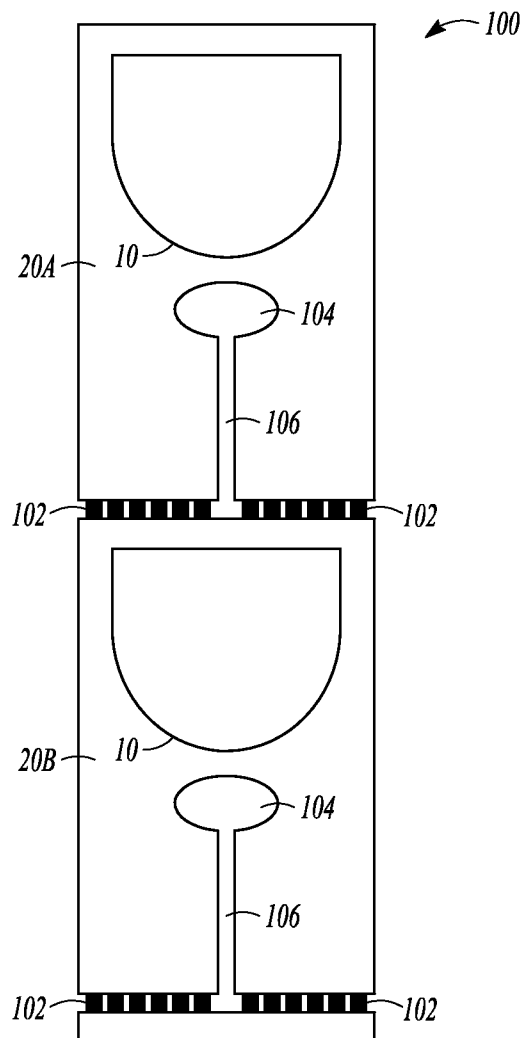

FIG. 10