

(No Model.)

3 Sheets—Sheet 1.

F. J. THOMAS.

SHAPING MACHINE WITH MILLING ATTACHMENT.

No. 525,476.

Patented Sept. 4, 1894.

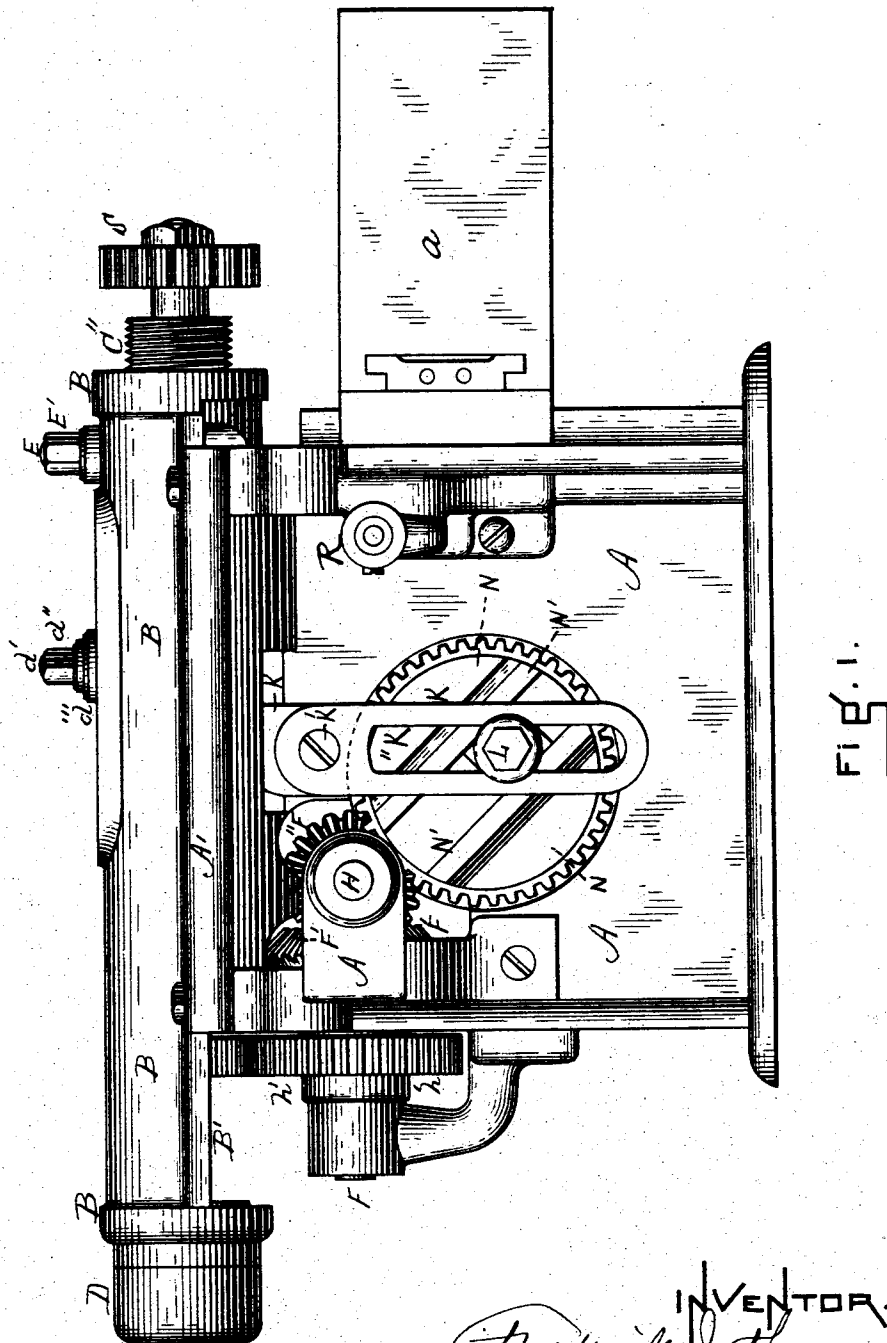

FIG. 1.

WITNESSES.  
J. M. Hartnett,  
B. W. Williams

INVENTOR.  
Frederick J. Thomas,  
By his Atty.  
Henry Williams.

(No Model.)

3 Sheets—Sheet 2.

F. J. THOMAS.

SHAPING MACHINE WITH MILLING ATTACHMENT.

No. 525,476.

Patented Sept. 4, 1894.

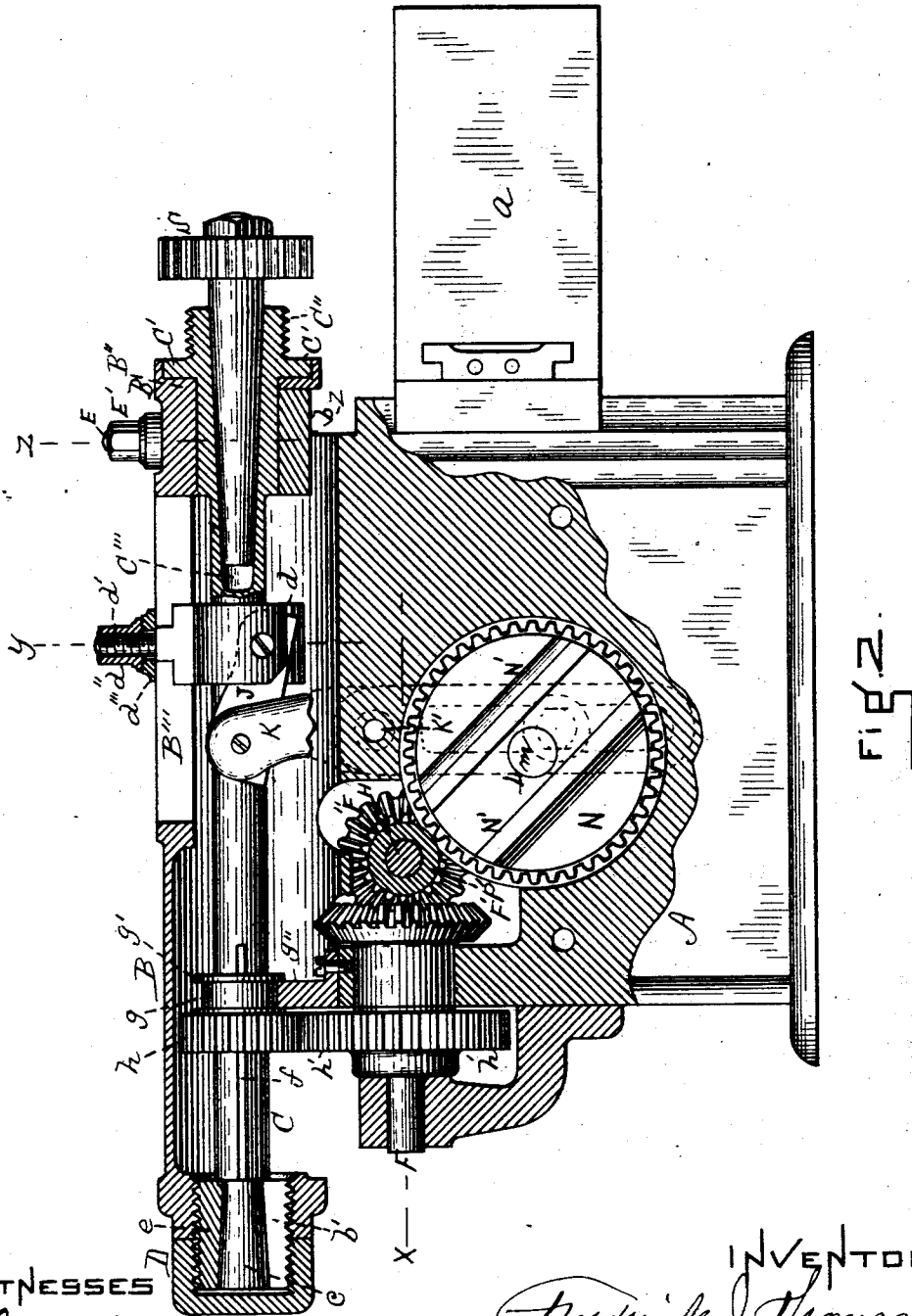

WITNESSES

*J. M. Hartnett,*  
*B. W. Williams*

INVENTOR

*Frederick J. Thomas,*  
 By *his Atty*  
*Sherry Williams*

(No Model.)

3 Sheets—Sheet 3.

F. J. THOMAS.

SHAPING MACHINE WITH MILLING ATTACHMENT.

No. 525,476.

Patented Sept. 4, 1894.

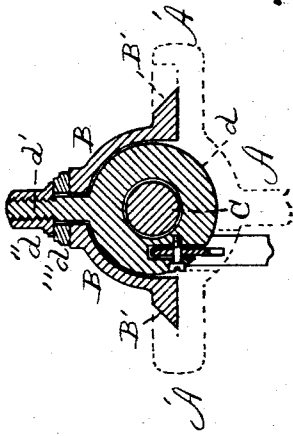

FIG. 4.

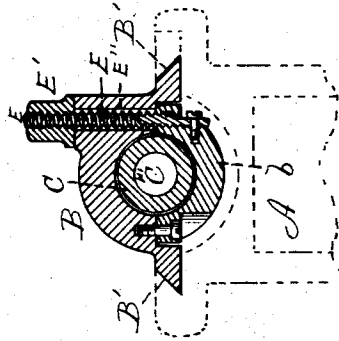

FIG. 5.

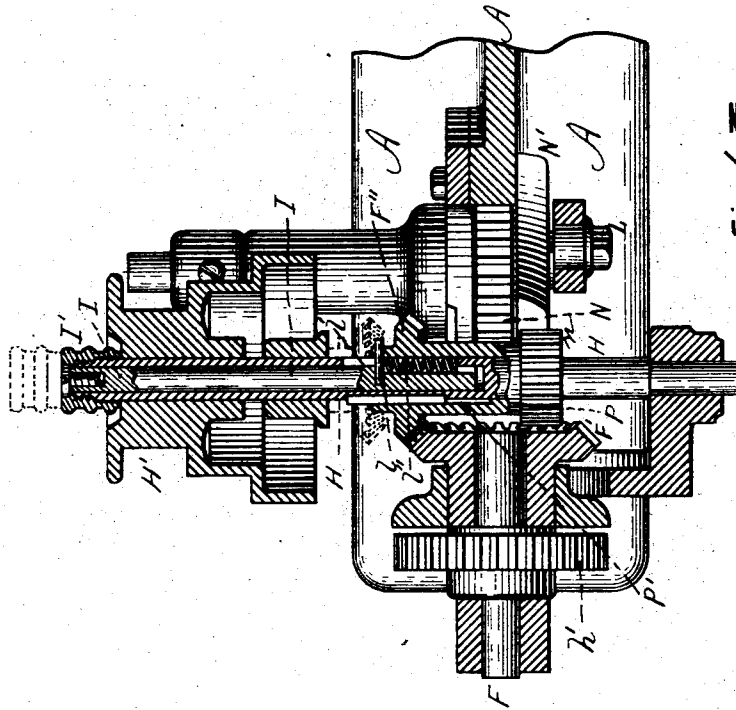

FIG. 6.

WITNESSES.

*J. M. Hartnett.*  
*B. M. Williams*

INVENTOR.

*Frederick J. Thomas,*  
*By his Atty.*  
*Henry Williams.*

# UNITED STATES PATENT OFFICE.

FREDERICK J. THOMAS, OF RAYNHAM, MASSACHUSETTS.

## SHAPING-MACHINE WITH MILLING ATTACHMENT.

SPECIFICATION forming part of Letters Patent No. 525,476, dated September 4, 1894.

Application filed October 5, 1893. Serial No. 487,253. (No model.)

To all whom it may concern:

Be it known that I, FREDERICK J. THOMAS, a citizen of the United States, residing at Raynham, in the county of Bristol and State of Massachusetts, have invented a new and useful Improvement in Shaping-Machines provided with Milling Attachments, of which the following is a specification.

This invention relates to a construction whereby a shaper may have either a shaping or a milling tool applied to the spindle, said spindle being adapted to turn when a milling tool is applied, and to reciprocate longitudinally when a shaping tool is applied.

The nature of the improvement is fully described below, and illustrated in the accompanying drawings, in which—

Figure 1 is a sufficient portion of a shaping machine to embody my invention, a milling attachment being shown in position thereon. Fig. 2 is a view mainly in longitudinal vertical section of the same. Fig. 3 is a horizontal section on line *x*, Fig. 2. Fig. 4 is a horizontal section on line *y*, Fig. 2. Fig. 5 is a horizontal section on line *z*, Fig. 2.

Similar letters of reference indicate corresponding parts.

A represents the frame provided at its top with a slide bed A' in which slides by means of suitable wings or flanges B' the ram B. *a* is an ordinary bed supported by the frame. Within said ram is a spindle C provided near its front end with an annular flange or shoulder C' and being screw threaded at C'', the object of the thread being to provide means for applying an ordinary shaping tool. This spindle is also provided with an ordinary tapered hole C''' at its front end, for the purpose of receiving the shank of an ordinary milling tool, as S.

The spindle C has its bearings near its front end in the box *b*, see Figs. 2 and 5, and at its rear end it is tapered at *c* as shown, and has its bearings in the correspondingly tapered split box *b'*, which is screwed into the rear end of the ram, and on which is screwed a shell D. This shell not only provides a finish for that end of the ram, but serves to draw out the box *b'*, and, by reason of the taper on the part *c*, draws the flange C' of the spindle against the shoulder B''. The

upper side of the ram B is provided with the longitudinal slot B''', through which a screw threaded shank *d'* projects, said shank extending up from a ring *d* surrounding the spindle C, as shown in Figs. 2 and 4. This ring forms a stiffening bearing for the spindle, and by means of a nut *d''* the washer *d'''* may be forced down upon the edges of the slot B''' and clamp the ram. This is done when the spindle and ram are to be longitudinally reciprocated, for the purpose of using a shaping tool screwed upon the portion C'', the milling tool S having been removed. At the same time, *i. e.* when a shaping tool is to be used, the nut E' on the screw E (Figs. 1, 2, and 5) which passes through a plain hole E'' in the ram into a threaded hole in the box *b*, is tightened so as to draw up the said box and prevent the spindle C from rotating.

The spindle C has secured to it by means of a spline *f*, a collet *g* which is prevented from lateral movement by its flanges *m'* which embrace a bracket or projection *g''* secured to and extending upward from the frame of the machine. A gear wheel *h* is made fast to the collet *g*, and, by means of the spline *f*, the spindle C can reciprocate longitudinally in said gear and collet. The gear *h* is engaged by the gear *h'* on the shaft F supported by the frame, and on the same shaft is a bevel gear F' which may be engaged by a bevel gear F'' on the shaft H. This shaft, as will be seen by reference to Fig. 3, is tubular for a considerable portion of its length, and is the driving shaft actuated by the pulley H'.

Within the driving shaft H is a shaft I capable of longitudinal movement, and provided with a nut I' adapted to screw onto the tubular shaft H. The bevel gear F'' is secured to the shaft I by means of a pin *l* extending through a slot *l'* in the tubular shaft *h*, and a spring *l''* lies between said pin and a shoulder produced by the end of the groove *l'*. By pushing the shaft I in the tubular portion of the shaft H and screwing the nut I' upon said shaft H against the power of the spring *l''*, the bevel gear F'' is brought into engagement with the bevel gear F'. Now if the nuts *d''* and E' are loosened so as to allow the spindle C to rotate freely within the

ring  $d$  and box  $b$ , a milling tool, as  $S$ , may be applied in the manner shown, and the spindle  $C$  will be rotated within the stationary ram  $B$  by the action of the driving pulley, through  
 5 the medium of the driving shaft  $H$ , shaft  $I$ , bevel gears  $F''$  and  $F'$ , shaft  $F$ , and gear wheels  $h'$  and  $h$ , the latter of which is splined upon the shaft, all as above described.

When the machine is desired to be used as  
 10 a shaper, the milling tool  $S$  is removed, and a shaping tool screwed onto the shaft  $C$  by means of the thread  $C''$ . The nut  $E'$  is tightened to prevent relative movement of the spindle and ram  $D$ , and the ring  $d$  is adjusted  
 15 in its desired position in the slot  $B'''$ , and held therein by tightening the nut  $d''$ . This ring is pivotally connected by means of a link  $J$  (Figs. 2 and 4) with a lever  $K$  pivoted at  $K'$  to the frame,—see Figs. 1 and 4, and  
 20 broken lines in Fig. 2. The long arm of this lever is slotted at  $K''$  to receive the wrist pin  $L$  adjustably secured in the slideway  $N'$  eccentrically to the face of the gear wheel  $N$  supported at  $m$  in the frame. This gear wheel  
 25 engages with the pinion  $n$  which is integral with a hub  $P$  extending from the gear wheel  $F''$ , and sliding longitudinally on the shaft  $H$  by means of a spline  $P'$ , see Fig. 3. When  
 30 the machine is to be operated as a shaper, the nut  $I'$  is loosened and flies into the position shown in broken lines in Fig. 3, by the action of the spring  $V''$  on the shaft  $I$ . This brings the bevel gear  $f''$  into the position  
 35 shown in broken lines in Fig. 3, and, by means of a connecting hub  $P'$ , draws the pinion  $n$  into engagement with the gear wheel  $N$ , which by means of the wrist pin  $L$ , slotted lever  $K$ , and link  $J$ , reciprocates the ring  $d$ ,

thus longitudinally reciprocating the spindle  $C$ , and ram  $B$ .

Thus it will be seen that the machine can  
 40 quickly be adapted for use either for shaping or milling purposes. When it is used as a shaper, the gear wheel  $h$  and collet  $g'$  remain stationary while the spindle  $C$  reciprocates.  
 45

An ordinary feed is shown at  $R$ .

Having thus fully described my invention, what I claim, and desire to secure by Letters  
 Patent, is—  
 50

1. The combination of the ram  $B$  sliding on the frame of the machine, the spindle  $C$  having bearings in the ram, the gear  $h$  and collet  $g$  splined to the spindle and engaging with  
 55 actuating gear and the frame respectively, and the ring or bearing  $d$  and shank  $d'$  adapted to reciprocate the spindle and ram longitudinally, substantially as described.

2. The combination of the frame, the spindle  $C$  rotating in the ram and geared to the  
 60 shaft  $F$ , bevel gear  $F'$  on said shaft, hollow driving spindle  $H$  provided with the bevel gear  $F''$ , shaft  $I$  sliding in the shaft  $H$  and provided with the pin  $l$  extending into a longitudinal slot in said shaft  $H$ , pinion  $n$  on the  
 65 shaft  $H$ , gear wheel  $N$  engaged by said pinion and mounted in the frame, said gear wheel being provided with a slideway  $N'$ , and the lever  $K$  pivoted on the frame and engaging at one end with the slideway and at the  
 70 other end with a link connecting with the spindle, substantially as set forth.

FREDERICK J. THOMAS.

Witnesses:

HENRY W. WILLIAMS,  
 J. M. HARTNETT.