

F. W. HERZ.
 SPRAYING MACHINE.

APPLICATION FILED MAR. 22, 1911.

Patented July 18, 1911.

998,579.

2 SHEETS—SHEET 1.

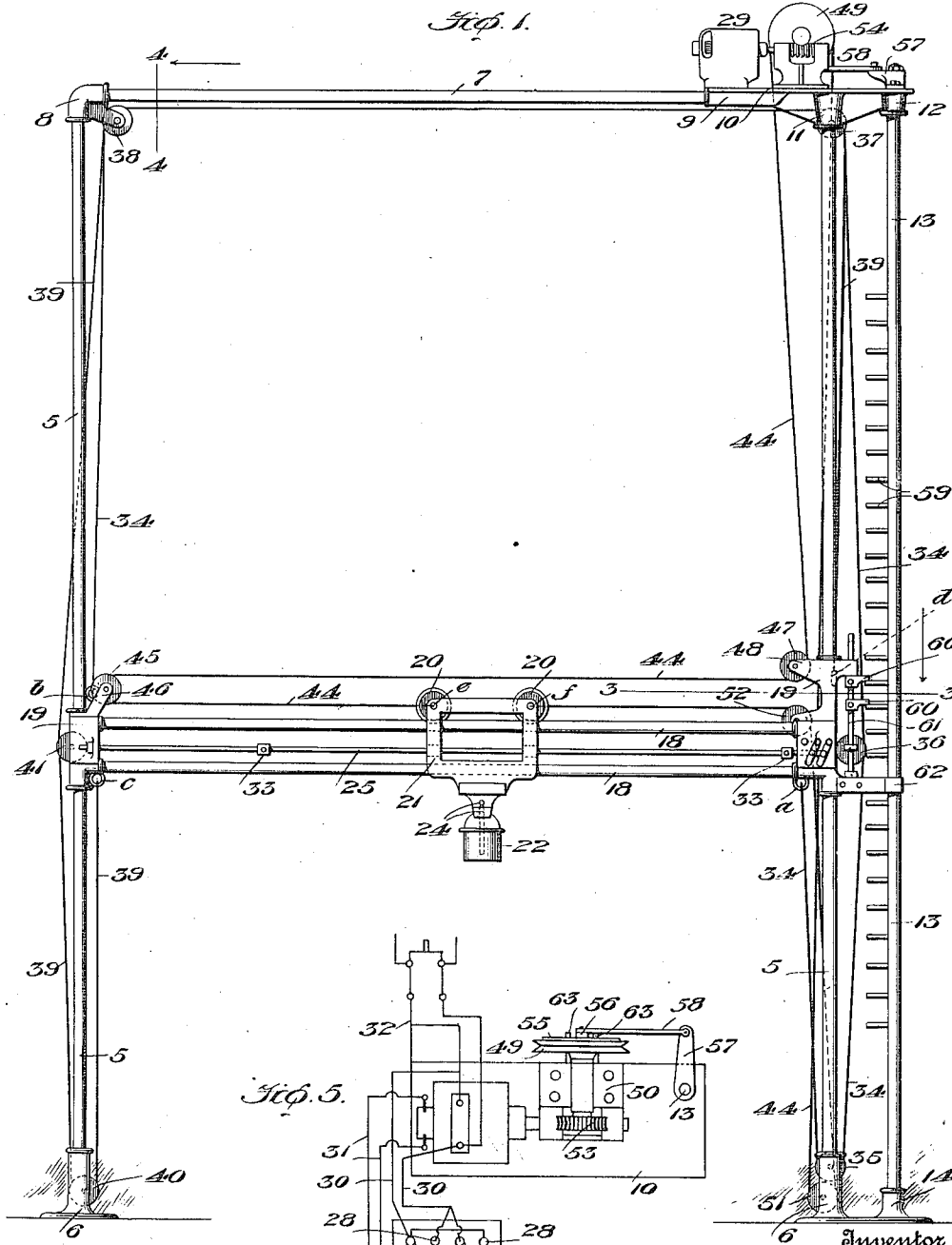

Witnesses

Charles Delevingne
 Charles Delevingne

Ferdinand W. Herz
 Ferdinand W. Herz

By *W. A. Edmond*
 W. A. Edmond
 Attorney

F. W. HERZ.
 SPRAYING MACHINE.
 APPLICATION FILED MAR. 22, 1911.

998,579.

Patented July 18, 1911.

2 SHEETS—SHEET 2.

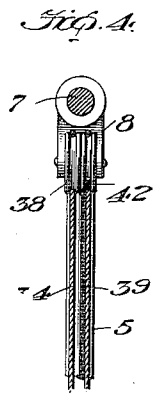
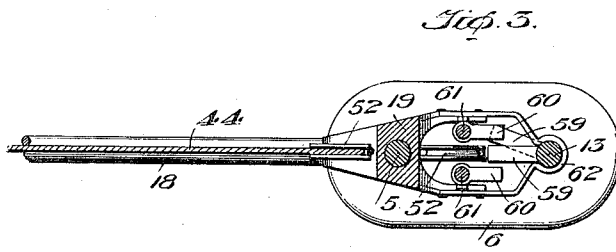
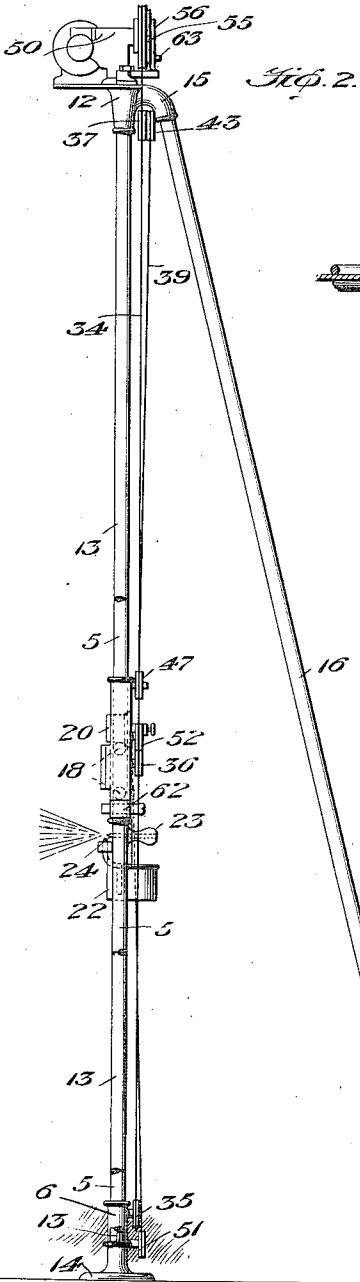

Inventor

Ferdinand W. Herz.

Witnesses

Charles Delevingne

By *W. A. Edmunds*

Attorney

UNITED STATES PATENT OFFICE.

FERDINAND W. HERZ, OF NEW YORK, N. Y., ASSIGNOR TO NATIONAL VARNISH COMPANY, OF LONG ISLAND CITY, NEW YORK, A CORPORATION OF NEW YORK.

SPRAYING-MACHINE.

998,579.

Specification of Letters Patent. Patented July 18, 1911.

Application filed March 22, 1911. Serial No. 616,290.

To all whom it may concern:

Be it known that I, FERDINAND W. HERZ, a citizen of the United States, residing at New York, in the county of New York and State of New York, have invented a certain new and useful Spraying-Machine, of which the following is a specification.

This invention relates, generally, to spraying machines, and particularly to a machine for applying paint or varnish to the surface to be covered in a continuous layer across the same and to be automatically lowered at the end of the stroke and the direction of travel of the spraying device, proper, reversed and another layer of the liquid applied parallel with and overlapping the edge of the first layer to produce a uniform layer over the entire surface operated upon, and it consists of the parts and combinations of parts hereinafter described and claimed.

In the accompanying drawings forming a part of this specification, Figure 1 is a front elevation of my improved machine. Fig. 2 is an end elevation of the same. Fig. 3 is a horizontal section on the line 3—3, Fig. 1. Fig. 4 is a vertical section on the line 4—4, Fig. 1, looking in the direction of the arrow. Fig. 5 is a diagrammatic view showing the wire connections from the switch to the motor.

Similar numerals refer to similar parts throughout all the views.

The frame of my machine is of few parts and they should be made of material of light weight and strong, and it may conveniently be constructed of metal, preferably in the shape of tubing or pipe, and in the present instance it consists of the two uprights 5, formed of tubing or pipes, which are firmly secured in erect positions in the base plates 6 by screwing the same thereto or by any other preferred manner, said uprights being connected at their upper ends by a transverse bar 7 formed of a tube or pipe, which is connected by an ell 8 at one end to one of the uprights and at the other enters a tubular member or socket 9 of a casting which forms the support for a table or platform 10, and which casting is also formed or provided with a socket 11 into which the other upright, 5, is inserted and secured, whereby both uprights are securely connected together. The casting is also formed with a socket member 12 to receive

the end of an oscillating shaft 13, also preferably formed of tubing, the lower end of which is stepped in a bearing 14 on one of the base plates 6. A socket member 15 is also provided for the upper end of the inclined supporting brace 16 which has its lower end fastened to a base plate 17. A pair of parallel bars 18 are secured at each end to slides 19 mounted on the uprights 5, the upper one of said bars serving as a track or way for the wheels 20 of a carrier 21, and the lower bar extending loosely through perforations formed in said carrier or through lugs formed thereon or secured thereto, in order to act as a guide for said carrier in its movement back and forth across the machine when in operation. From the carrier 21 the reservoir 22 containing the liquid, such for instance as varnish, is detachably supported as is also the nozzle 23 to which one end of a flexible hose pipe leading from a compressed air supply may be attached, said nozzle discharging immediately over and at right angles across the opening in a tube 24 which communicates with the liquid in the reservoir 22, and thus raises the contents of the reservoir and, by contact, disperses and reduces it to a spray form which is directed onto the surface to be covered thereby. A switch rod 25 extends loosely through the frame of the carrier and is slidably mounted at each end in the slides 19, and at one end is connected to the link 26 which connects the switch arms 27 which are pivoted at one end to one of the slides 19, or to a board secured thereto, so as to shift said arms simultaneously into and out of contact with the metallic buttons 28 when said rod is moved longitudinally in order to reverse the current and thereby reverse the direction of rotation of the motor 29. The flexible twin cord or wires 30 connecting the switch and motor, and the flexible cords or wires 31 connecting the brushes with the switch are of sufficient length to allow of the vertical travel of the slides, and, of a consequence, the carrier their full limits. The connection between the motor and the source of energy is made through the wires 32. The switch rod 25 is provided with adjustable stops 33, between which the carrier is hung so that it may engage one or the other of said stops—according to the direction in which it is moving—in order to actuate the rod and thereby shift the switch arms and

reverse the direction of rotation of the motor.

To insure a parallel movement of the carrier with the floor a wire or cord 34 is attached at one end to the right hand slide at *a*, and is led downwardly therefrom to and around an idler pulley 35, mounted on the frame, thence upwardly and past a guide pulley 36, mounted on one of the slides 19, and over a pulley 37, journaled on the casting at the top of the frame, over which it passes to a similar pulley 38 at the opposite end of the frame, and down to the other or left hand slide and is attached to said slide at 6. A similar wire or cord 39 is attached to the left hand slide at *c* and passes down to and around a pulley 40, journaled to the frame, and up past a guide pulley 41, journaled to the left hand slide, to a pulley 42, journaled alongside the pulley 38, and over said pulley 42 to a similar pulley 43 journaled alongside the pulley 37, and thence down to the right hand slide where it is secured at *d*, whereby the carrier supporting bars are held parallel to the floor on which the machine rests and binding or cramping of the slides 19 is prevented.

The carrier is automatically reciprocated across the frame, the distance traveled being limited by the stops 33, by means of a cord 44 which is attached to one end of the carrier, as at *e*, thence to a pulley 45, journaled in arms 46 projecting from one of the slides 19, around which it passes and is carried back across the machine to and around a pulley 47, journaled in arms 48 projecting from the other slide 19, and thence up to and over a sheave pulley 49, which is mounted on one end of a shaft journaled in bearings 50 on the platform or table 10, and from last-named pulley it passes down to and around a pulley 51 at the bottom of the frame and thence up to and over a pulley 52, carried by one of the slides 19, to the other end of the carrier where it is secured, as at *f*.

The shaft for the sheave pulley carries a gear 53 at its opposite end which is engaged by a worm 54 on the shaft of the motor, whereby said sheave pulley is rotated. A friction disk 55 is loosely mounted on the sheave shaft and is held in frictional contact with and is rotated by said sheave in order to rotate an arm 56 secured to said disk which is connected to a lever 57 by a link 58, said lever 57 being secured to the upper end of the oscillating shaft 13, which carries a series of staggered pins 59. The pins 59 control the distance the carrier may drop at the end of each of its transverse movements, and said pins are arranged so as to adapt them to alternately engage the stops or rests 60 which are secured on standards 61 secured to one of the slides 19, which slide also carries a guide 62, through which the shaft 13 extends, to insure engagement

between the pins and stops or rests 60. The shaft 13 is oscillated in one or the other direction each time the motor is reversed, but its continued revolution is prevented by reason of the arm 56 coming into contact with one or the other of the stops 63 which are secured to the table or platform and extend or project into the path of travel of the said arm, 56, and thereby arrests the same and overcomes the friction between the disk and sheave and holds the former stationary until the motor is reversed and the sheave turned or rotated in the opposite direction.

From the above description it will be obvious that the carrier will be automatically moved across the machine upon switching on the current to the motor, and that the engagement of the carrier with either of the stops 33 will operate the switch to reverse the motor and that the shaft 13 will be instantly oscillated so as to shift the pins 59 from under the rests 60 and thus permit the slides to drop the vertical distance between the escapement pins 59 and come to rest on the next pin below. The reversal of the motor reverses the direction of rotation of the sheave pulley 49 and the direction of travel of the cord 44 is reversed and the carrier moved back or across the machine on a lower plane.

A constant air pressure is maintained and the distance of the work, or surface to be covered, from the jet determines the area to be covered by one pass across the work. The distance of the work from the jet is in proportion to air pressure and space between the escapement pins in order to cause the overlap of each layer to equalize and form a uniform layer of the liquid applied to the work.

The work is placed in a vertical position opposite the machine and at a predetermined distance therefrom. The slides are then raised to a level with the top of the work and the air pressure turned on starting a spray of the liquid, and the motor is started, causing the jet to travel across the work until the carrier strikes one of the adjustable stops 33, and moves the switch rod which reverses the motor, and operates the escapement shaft and drops the jet for return movement on to the next or lower level.

When the carrier reaches the lowest point the link 58 is disengaged and the shaft 13 is partly rotated to remove its pins from the path of the rests 60 and the slides are raised to any desired height for the next operation.

Having thus described my invention what I claim is:

1. In a spraying machine, a horizontally reciprocating nozzle and liquid carrier working in a vertical plane, and means for changing the horizontal plane of travel of said carrier at the end of its stroke in each direction.

2. In a spraying machine, a nozzle and liquid carrier working in a vertical plane, means for reciprocating said carrier in a horizontal plane, and means for lowering said carrier a predetermined distance at the end of its stroke in each direction.

3. In a spraying machine, a nozzle and liquid carrier, a motor for horizontally reciprocating said carrier, and means operated by said carrier to reverse the motor and to permit the carrier to gravitate to a lower plane of travel at the end of its stroke in each direction.

4. In a spraying machine, a nozzle and liquid carrier, a vertically movable way or track for said carrier, means for reciprocating said carrier, and means operated by said carrier at the end of its stroke in each direction to reverse the direction of travel of the carrier and to lower the track or way a predetermined distance.

5. In a spraying machine, a reciprocating

nozzle, and liquid carrier, a vertically movable support for said carrier, means for maintaining the parallelism of the said support with the base of the machine, means for reciprocating the carrier, and means for vertically moving the support at the end of the stroke of the carrier in each direction.

6. In a spraying machine, a nozzle and liquid carrier, a track or way for said carrier, vertically movable slides for the ends of said track, a motor for reciprocating said carrier, a vertical shaft for supporting said slides, and means operated by the carrier for reversing the motor and oscillating said shaft at the end of the stroke of the carrier in each direction.

In testimony whereof, I affix my signature, in the presence of two witnesses.

FERDINAND W. HERZ.

Witnesses:

LOUIS JACKSON,
WM. HERZ.