

L. S. INGRAHAM,
Grain Winnower.

No. 9,920.

Patented Aug. 9, 1853

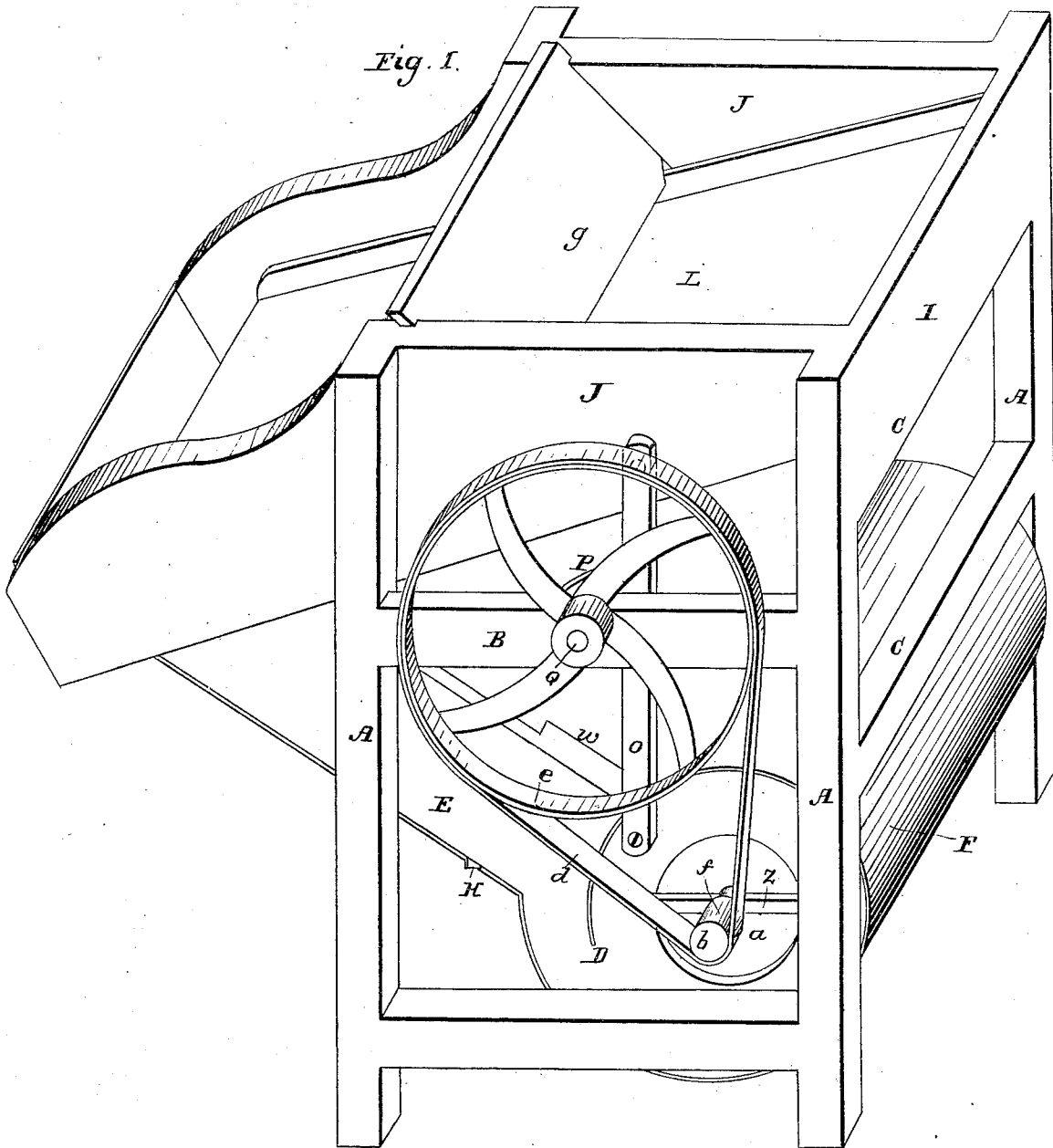

L. S. INGRAHAM.
Grain Winnower.

2 Sheets—Sheet 2.

No. 9,920.

Patented Aug. 9, 1853.

Fig. 2.

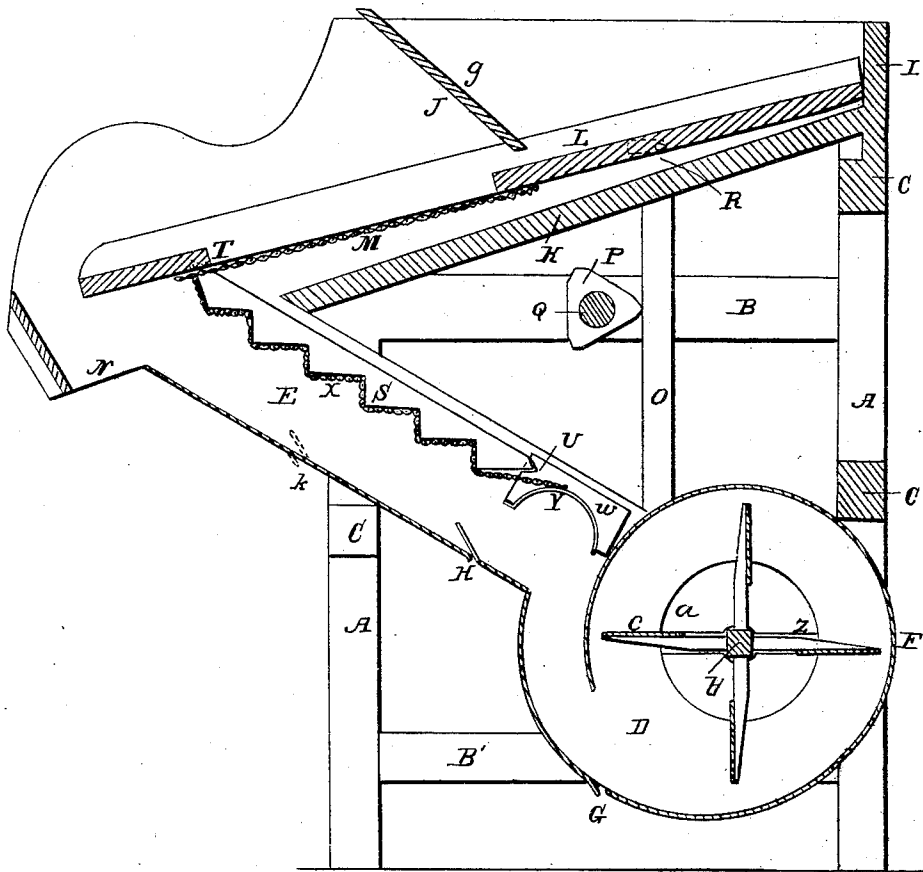

UNITED STATES PATENT OFFICE.

LEWIS S. INGRAHAM, OF CUYAHOGA FALLS, OHIO.

WINNOWER.

Specification of Letters Patent No. 9,920, dated August 9, 1853.

To all whom it may concern:

Be it known that I, LEWIS S. INGRAHAM, of Cuyahoga Falls, in the county of Summit and State of Ohio, have invented certain new and useful Improvements in Machines for Separating Grain, Gold, &c.; and I do hereby declare that the same are described and represented in the following specification and drawings.

10 The nature of my invention consists in making the screen or screens stair-shaped or fluted, and vibrating them perpendicularly or diagonally instead of traversing or shaking them horizontally as heretofore; so
15 that the grain falls successively from one stair or flute to the next, until it passes over all the stairs or flutes in the screen; also in using it in combination with a plain screen which may be used either before or
20 after the stair screen, as may be preferred.

To enable others skilled in the arts to make and use my improvements I will proceed to describe their construction and use referring to the drawings above mentioned,
25 in which the same letters indicate like parts in each of the figures.

Figure 1 is an isometrical view of the machine with my improvements. Fig. 2 is a sectional elevation representing the machine as cut through the center perpendicu-
30 larly.

A A the posts connected together by the girts B B' and C C so as to form a frame as represented, to which frame I fasten the
35 boards D D made in the form represented so as to form the ends of the fan box and the sides of the trough E. I make the circular portion of the fan box of sheet metal bent in the form shown at F, with an opening
40 G for the grain to fall through, and an opening H in the bottom of the trough E (which is also made of sheet metal) for the escape of the small seeds separated from the grain. There is an end board I and
45 two side boards J J fastened to the posts and a bottom board K fastened between the boards J J, between which boards I arrange a traversing shoe L with a screen M in it to separate all the straw and refuse matter
50 from the grain which passes freely through it; while the refuse matter passes over the screen and falls out of the machine at N as the shoe is traversed by the levers O O fastened to the boards D so as to vibrate

freely when acted upon by the cams P, P, 55
upon the shaft Q, which shaft turns in the holes made for it in the girts B. The levers O O are connected to the shoe L by the rod R which passes through the levers and the bottom of the shoe and traverses in slots in
60 the boards J J. The lower end of the shoe L, is supported by two braces like S, the upper end catching into the notch T in the bottom of the shoe and the lower end in the notch U in the cleat W, fastened to the
65 board D so that the upper ends of the braces are vibrated by the shoe L so as to vibrate the stair screen X fastened to the underside of the braces S as represented. The cleat W is hollowed out on the lower
70 slide to receive the curved metal plate Y upon which the lower end of the screen X rests and over which the grain passes as it falls into the fan blast. There are two
75 metallic supports or bars Z Z fastened to the boards D across the apertures a a with holes in them in which the shaft b of the fan c turns as it is operated by the belt d from the pulley e upon the shaft Q to the pulley f on the shaft b as represented. 80
There is a gate g fitted to traverse in grooves in the boards J J which gate may be adjusted so as to regulate the quantity of grain fed onto the screen M.

The machine having been constructed and 85
completed as above described, the grain to be cleaned is put onto the shoe L which is vibrated and it passes under the gate g onto the screen M which retains the straw, etc., and all matter larger than the grain
90 which passes through the screen and falls onto the inclined board K, while the straw, etc., passes off at the lower end of the shoe and falls out of the machine at N; while the grain descends from the inclined board
95 K onto the stair screen S which permits the seed of weeds and any matter smaller than the grain to pass through it into the trough E and out of the opening H; while the screen is agitated; and while it is fanned
100 by the blast from the fan c, and the grain descends from stair to stair, of the screen X and passes over the curved plate Y into the blast from the fan which blows out every thing lighter than the grain and im-
105 perfect kernels; while the good grain descends through the blast and passes out of the machine at G.

The machine may be operated by a crank or pulleys applied to the shaft Q.

What I claim as my invention and desire to secure by Letters Patent is,

5 The stair or fluted screen X, constructed and operated substantially as described for the purposes set forth.

In testimony whereof, I have hereunto signed my name before two subscribing witnesses.

LEWIS S. INGRAHAM.

Witnesses:

S. C. DONN,
H. RATCLIFF.