

PCTWORLD INTELLECTUAL PRO
International

INTERNATIONAL APPLICATION PUBLISHED UNDER

WO 9607786A1

(51) International Patent Classification ⁶ :
D21C 3/02, 3/24, 7/00

A1

(11) International Publication Number: WO 96/07786**(43) International Publication Date:** 14 March 1996 (14.03.96)**(21) International Application Number:** PCT/US95/07074**(22) International Filing Date:** 2 June 1995 (02.06.95)**(30) Priority Data:**
299,103 2 September 1994 (02.09.94) US**(71) Applicant:** KAMYR, INC. [US/US]; Ridge Center, Glens Falls, NY 12801-3686 (US).**(72) Inventors:** HENRICSON, Kaj, O.; A. Ahlstrom Corporation, FIN-48601 Karhula, Kotka (FI). TERVOLA, Pekka; Calconiuksenkatu 7B 23, FIN-00100 Helsinki (FI).**(74) Agent:** VANDERHYTE, Robert, A.; Nixon & Vanderhite P.C., 8th floor, 1100 North Glebe Road, Arlington, VA 22201-4714 (US).**(81) Designated States:** AU, BR, CA, CN, FI, JP, NZ, RU, European patent (AT, BE, CH, DE, DK, ES, FR, GB, GR, IE, IT, LU, MC, NL, PT, SE).**Published**
*With international search report.***(54) Title:** CONTINUOUS KRAFT COOKING WITH BLACK LIQUOR PRETREATMENT**(57) Abstract**

A method and continuous digester system provide for a high Na₂S concentration in the beginning of the cook of comminuted cellulosic fibrous material to produce cellulose pulp, providing a more selective cook and potential to lower cooking kappa. Two different streams of spent (e.g. "sulphurous" and "black") liquor are removed from different screens associated with continuous digesters. The spent liquor removed from the uppermost screen has a relatively high effective alkali and Na₂S concentration. The second spent liquor, removed from the second screen, has effective alkali and Na₂S concentrations which are at least 25 % less than for the first spent liquor. The first spent liquor is circulated to an impregnation vessel, or other part of a chip feed system, to enhance the amount of sulphur present at the beginning of the cooking stage in the digester. The second spent liquor may be used in a number of ways, including - with or without first passing it through a flash tank - circulating it to a chip slurring system for slurring the chips so that they can be fed to the digester. The steaming and slurring system may include only an unpressurized chip bin, chip feeder, slurring vessel, and high pressure feeder, thus being simpler than conventional constructions.

FOR THE PURPOSES OF INFORMATION ONLY

Codes used to identify States party to the PCT on the front pages of pamphlets publishing international applications under the PCT.

AT	Austria	GB	United Kingdom	MR	Mauritania
AU	Australia	GE	Georgia	MW	Malawi
BB	Barbados	GN	Guinea	NE	Niger
BE	Belgium	GR	Greece	NL	Netherlands
BF	Burkina Faso	HU	Hungary	NO	Norway
BG	Bulgaria	IE	Ireland	NZ	New Zealand
BJ	Benin	IT	Italy	PL	Poland
BR	Brazil	JP	Japan	PT	Portugal
BY	Belarus	KE	Kenya	RO	Romania
CA	Canada	KG	Kyrgystan	RU	Russian Federation
CF	Central African Republic	KP	Democratic People's Republic of Korea	SD	Sudan
CG	Congo	KR	Republic of Korea	SE	Sweden
CH	Switzerland	KZ	Kazakhstan	SI	Slovenia
CI	Côte d'Ivoire	LI	Liechtenstein	SK	Slovakia
CM	Cameroon	LK	Sri Lanka	SN	Senegal
CN	China	LU	Luxembourg	TD	Chad
CS	Czechoslovakia	LV	Latvia	TG	Togo
CZ	Czech Republic	MC	Monaco	TJ	Tajikistan
DE	Germany	MD	Republic of Moldova	TT	Trinidad and Tobago
DK	Denmark	MG	Madagascar	UA	Ukraine
ES	Spain	ML	Mali	US	United States of America
FI	Finland	MN	Mongolia	UZ	Uzbekistan
FR	France			VN	Viet Nam
GA	Gabon				

**CONTINUOUS KRAFT COOKING WITH BLACK LIQUOR
PRETREATMENT**

5 **BACKGROUND AND SUMMARY OF THE INVENTION**

In kraft cooking, wood is delignified by a cooking liquor where the active components are Na_2S and NaOH . Na_2S is preferably primarily active at the beginning of the cook, and NaOH is preferably
10 active at the end of the cook. The invention relates to a method of increasing Na_2S concentration in the beginning of the cook. A high Na_2S concentration in the beginning of the cook gives a more selective cook and the possibility of lowering pulp kappa.

Spent kraft cooking liquor, or black liquor, has been re-
15 circulated for re-use in various fashions in prior art continuous kraft cooking systems. For example in U.S. patent 3,802,956, black liquor is added to the feed system of a continuous digester to aid in flushing chips from the high pressure transfer device (i.e., the high pressure feeder) to the top of the impregnation vessel. In U.S. patents
20 5,080,755 and 5,192,396 black liquor is used to supplement the liquor extracted in the impregnation vessel. These patents disclose a method of introducing co- and counter-current chip impregnation in an impregnation vessel by extracting liquor at a midpoint in the vessel. The re-circulated black liquor is used to increase the liquor
25 volume (i.e., the liquor-to-wood ratio) to limit the alkali concentration increase caused by the extraction. The black liquor also improves the chip column movement.

In the early 1980s, based upon work performed by Sjoblom et al at the Swedish Royal Institute of Technology, it was recognized
30 that the presence of sulfides in the early stages of kraft cooking can

improve the strength of the resulting pulp. Attempts have been made to use the sulfides present in black liquor to provide the sulfide desired. U.S. patents 5,053,108 and 5,236,553 disclose a method of continuous kraft cooking in which black liquor is re-circulated to the feed system to treat the wood chips. In the '108 patent this treatment takes place in the chip chute and is referred to as "sulfonation". In the '553 patent, the black liquor is re-circulated to a chip chute/slurrying vessel. In both patents a single source of black liquor is used.

10 Recent mathematical modeling pursuant to the invention suggests that a preferred method of pre-treating chips is by using two forms of black liquor: one of relatively weak sulfide concentration and one of relatively strong sulfide concentration. The invention provides such two different streams in a practical manner.

15 According to one aspect of the present invention, a method of continuously kraft cooking comminuted cellulosic fibrous material utilizing an upright continuous digester having first and second extraction screens, a top, and a bottom, is provided. The method comprises the steps of continuously: (a) Feeding comminuted
20 cellulosic fibrous material slurry to the top of the digester. (b) Cooking the material in the digester as it passes downwardly therein, at a cooking temperature of about 150-170°C, producing spent liquor during cooking while digesting the material. (c) Using the first extraction screen, withdrawing a first spent liquor from the digester
25 having a first amount of effective alkali and a first Na₂S concentration. (d) Using the second extraction screen, withdrawing a second spent liquor from the digester having a second amount of effective alkali and a second Na₂S concentration, each of which are at least 25% less than the first amount of effective alkali and first Na₂S
30 concentration. (e) Combining at least some of the first spent liquor

with the material prior to step (b) to enhance the amount of sulfur present at the beginning of step (b). And, (f) withdrawing pulp from the bottom of the digester.

In the practice of the method described above, step (c) is typically practiced to extract as the first spent liquor a liquor having an effective alkali concentration of about 10-50 g/l and an Na₂S concentration (assuming original sulfidity of the cooking liquor of greater than about 25%) of greater than about 35 g/l. The first liquor is also typically at a temperature of about 140-170°C and in an amount of about 2-6 m³/t.p.

Step (d) of the above method is typically practiced to extract as the second spent liquor a liquor having an effective alkali concentration of about 5-20 g/l (typically half or less of the concentration of the first liquor), and an Na₂S concentration of less than about 20 g/l (typically less than half of that of the first liquor). The second liquor typically has a temperature of about 120-160°C and is extracted in an amount of about 2-6 m³/t.p.

The digester may comprise a two vessel hydraulic system including a first impregnation vessel, in which case step (e) may be practiced to introduce the first spent liquor into the bottom of the impregnation vessel to flow countercurrently to the material therein, or the digester may comprise a single vessel hydraulic digester in which case the first liquor may be introduced into the slurry any time prior to the practice of step (a).

The second spent liquor may be flashed to steam in a flash tank, and a more concentrated second spent liquor which is withdrawn from the bottom of the flash tank may be used to slurry the comminuted cellulosic fibrous material prior to step (a). For example where a high pressure transfer device is provided (high pressure feeder) having a feed circulation loop, which transfer device

feeds slurry to the top of the top of the digester (either directly or through an impregnation vessel), the more concentrated second spent liquor may be introduced into contact with the material in the feed circulation loop of the high pressure transfer device, i.e. slurring the material. The first liquor may also be flashed if desired, before adding it to the cellulosic material upstream of the digester cooking zone.

In order to enhance further the amount of sulphur present at the beginning of the cook, there may be the further step of supplementing the first spent liquor with just above 0 to about 2 m³/ton of pulp of green liquor.

According to another aspect of the present invention a method of continuously digesting comminuted cellulosic fibrous material to produce cellulose pulp comprises the steps of substantially consecutively and continuously: (a) Slurring the material with liquor. (b) Treating the material with a first sulphurous liquor having an effective alkali concentration of about 10-50 g/l and an Na₂S concentration of at least about 35 g/l (e. g. 40-60 g/l). (c) Cooking the material with cooking liquor having an effective alkali concentration of over 100 g/l and a sulfidity of at least about 25% at a cooking temperature of about 150-170°C to produce pulp. (d) Separating the first sulphurous liquor from the pulp. (e) Separating a second liquor from the pulp having a different effective alkali concentration and Na₂S concentration than the first liquor. And, (f) washing the pulp.

In the practice of the above method, step (a) may be practiced, at least in part, using the second liquor from step (e). The first and second liquors preferably have the temperature ranges and volumes described above with respect to a first aspect of the present invention. The second liquor typically has an effective alkali

concentration of about 5-20 g/l (e.g. about 10 g/l) and less than the effective alkali concentration of the first liquor, and has an Na_2S concentration of less than about 20 g/l (e.g. about 10-15 g/l).

According to another aspect of the present invention a
5 continuous digester system is provided. The continuous digester system comprises the following elements: An upright digester vessel having a top and a bottom. A chip slurry feed inlet adjacent the top of the vessel. A chip feed system connected to the chip feed inlet. A pulp outlet adjacent the bottom of the vessel. A separating device
10 adjacent the top of the vessel for separating some liquor from chips fed into the chip feed inlet and returning it to the chip feed system. At least one upper screen in the vessel distinct from the separating device. A first extraction screen in the vessel below the at least one upper screen, and for extracting a first spent liquor. A second
15 extraction screen in the vessel below the first extraction screen and for extracting a second spent liquor distinct from the first spent liquor. And, a first conduit for circulating the first spent liquor to the chip feed system.

In the continuous digester system described above, a chip
20 slurring system is also preferably provided connected to the chip feed system opposite the digester. A second conduit is also provided for circulating liquor from the second extraction screen to the slurring system. The second conduit may be connected directly to the slurring system, or through one or more flash tanks.

25 The invention also may include a simplified steaming and slurring system associated with the digester. For example instead of utilizing a chips bin, chip meter, chip feeder, horizontal steaming vessel, slurring vessel, and high pressure feeder, the steaming and slurring system may consist essentially of only a chip bin, chip
30 feeder, slurring vessel (e.g. chute), and high pressure feeder.

The continuous digester system may comprise any of a wide variety of conventional digester systems including digesters available from Kamyr, Inc. of Glens Falls, New York and sold under the trademarks MCC®, EMCC®, and LO-SOLIDS™; the continuous
5 digester system may include a single vessel hydraulic system, a two vessel hydraulic system (with an impregnation vessel in addition to the digester), or other conventional systems. Where an impregnation vessel is utilized, the first conduit may be connected to the
10 impregnation vessel. In the impregnation vessel the first, sulphurous, liquor typically flows countercurrently to the cellulosic material, but may instead be directed to flow co-currently.

It is the primary object of the present invention to provide two or more different streams of spent cooking liquors so as to provide a
15 high Na_2S concentration in the beginning of a kraft cook, resulting in a selective cook and the potential to lower cooking kappa (i.e. easily below 20), and a simplified chip feeding system. This and other objects of the invention will become clear from an inspection of the detailed description of the invention and from the appended claims.

20

BRIEF DESCRIPTION OF THE DRAWINGS

FIGURE 1 is a schematic view of exemplary apparatus for practicing the method of continuous kraft cooking with black liquor
25 pretreatment according to the present invention;

FIGURE 2 is a view like that of FIGURE 1 utilizing a conventional Kamyr® two vessel hydraulic digester system with co-current liquor flow in the top of the digester;

30

FIGURE 3 is a view like that of FIGURE 2 only not showing the chip bin and other conventional components, and showing a countercurrent liquor flow in the top of the digester;

5 FIGURE 4 is a view like that of FIGURE 2 for a single vessel hydraulic EMCC® digester system;

FIGURE 5 is a schematic view of a conventional prior art chip feeding system for a continuous digester; and

10

FIGURE 6 is a schematic side view of a modified chip feeding system for a continuous digester that may be utilized in the practice of the present invention.

15

DETAILED DESCRIPTION OF THE DRAWINGS

Exemplary apparatus for practicing an exemplary method according to the present invention is shown schematically in FIGURE 1. In the description of FIGURE 1, and the other figures that follow, 20 the comminuted cellulosic fibrous material that is digested to produce cellulose pulp will be referred to as "chips", since wood chips are typically used in the production of cellulose pulp. However it is to be understood that a wide variety of different types of cellulosic material can be utilized besides wood chips.

25 Presteamed chips in line 10 are fed to a first, impregnation, vessel 11. The chips 10 are presteamed and pressurized in a slurring and steaming system shown in FIGURES 2 or 3. From the vessel 11 the chips are transported via line 12 to the digester 13. Cooking liquor, typically white liquor (WL), primarily comprising 30 Na₂S and NaOH as the active ingredients, is added to the lower

portion 14 of vessel 11 and upper portion 15 of vessel 13. Additional cooking liquor may be added to even out the alkali profile according to cooking methods such as those using MCC®, EMCC® or LO-SOLIDS™ digesters. As an example, WL is added in FIGURE 1 to
 5 the bottom 16 of vessel 13.

Initially the chips are steamed to remove air and to allow ready penetration by impregnating and cooking liquors, as is conventional. The actual cooking takes place in upper parts of digester 13. During the end and later parts of the cook the NaOH
 10 concentration decreases. According to the invention, the cooking vessel 13 is equipped with two separate extraction screens 17 and 18. With the first extraction screen 17 is extracted liquor surrounding the chips which liquor still contains active cooking chemicals NaOH and Na₂S. This first, spent, extracted liquor in conduit 19 is, due to
 15 the cooking kinetics, rich in Na₂S and very useful in the beginning of the cook (e.g. at the top of vessel 13), but not as useful where it is present at the end of the cook where primarily NaOH is needed. This first, spent liquor, which may be called sulphurous liquor, is thus separated to be used in earlier phases of the cook. Typical
 20 properties of the sulphurous liquor in line 19 are ("tw" means "ton of wood"):

temperature	155°C (140-170°C)
effective alkali	20 g/l (10-50 g/l)
amount	4 m ³ /tw (2-6 m ³ /tw)
25 Na ₂ S	>35 g/l (e.g. 40-60 g/l)

[Note that all chemical concentrations are based upon equivalent NaOH].

After the useful sulphurous liquor has been separated, the cook continues for a while after which a second, spent residual liquor,
 30 called black liquor, is separated by second screen 18 into second

conduit 20. The black liquor in conduit 20 contains residual cooking chemicals and dissolved lignin and wash liquid introduced into conduit 21 used to wash the pulp. Typical properties of the black liquor in conduit 20 are:

5	temperature	150° C (120-160° C)
	effective alkali	10 g/l (5-20 g/l)
	amount	4 m ³ /tw (2-6 m ³ /tw)
	Na ₂ S	<20 g/l

The second spent liquor (black liquor) in conduit 20 is so
10 depleted in cooking chemicals that it has no significant potential as a cooking liquor. However it can be utilized in a number of different ways before it is ultimately passed to a conventional recovery system. For example, as illustrated in FIGURE 1, it may pass to a flash tank 22 to produce steam 23 that is used in presteaming the chips 10,
15 with a more concentrated second (black) liquor removed from the flash tank in line 24.

Note that the first and second extraction screens 17, 18 respectively are toward the end of the cooking zone in the digester 13. In the exemplary embodiment illustrated in FIGURE 1 these
20 screens are located near the middle of the digester 13, but below at least one upper screen 25, the upper screen 25 illustrated in FIGURE 1 associated with the conventional recirculation loop 26, to which white liquor may be added if desired. Typical white liquor that is used will have, during cooking, an active alkali content of at least
25 about 100 g/l, and a sulfidity of at least about 25%. The sulfidity may vary depending upon where the white liquor is introduced. For example using known "split sulfidity" techniques, the liquor introduced initially (e.g. at 14, 15) may have higher sulfidity (e.g. above 40%), while white liquor introduced later on (e.g. at 16) lower

sulfidity (e.g. below 30%). The temperature during cooking is around 160°C, preferably about 150-170°C.

The first spent liquor from conduit 19 is mixed with the presteamed chips in line 10 prior to introduction into the top 15 of the digester 13. [The first liquor may also be flashed to recover steam, if desired, before being mixed with the presteamed chips in line 10.] This is preferably accomplished -- as illustrated in FIGURE 1 -- by introducing it into the recirculatory loop 28 at the bottom of impregnation vessel 11. In this case the first, sulphurous, liquor 10 flows upwardly in the impregnation vessel 11 countercurrent to the flow of chips (downward) adjacent the bottom of the vessel 11. The temperature at the circulation 28 is typically about 150°C (130-160°C). Here the sulphurous liquor reacts with the wood and sulphur diffuses into the chips. Typical reaction and diffusion times 15 are about 30 minutes (e.g. 20-40 minutes).

Preferably -- as also illustrated in FIGURE 1 -- the second spent liquor (black liquor) from conduit 24 is introduced into the vessel 11 adjacent the circulation 30, slurring the presteamed chips in conduit 10. Here the temperature is about 90-120°C. The black 20 liquor flows downwardly with the chips in the vessel 11 until the intermediate extraction screen 31 is reached.

The extraction screen 31 extracts "final" black liquor. For example two different streams may be provided, a first stream 32 which is recirculated back to the line 24 for introduction at 30 to 25 slurry the chips, and a second portion 33 which is fed to the flash tank 34. Steam 35 produced in flash tank 34 is fed to presteam the chips in line 10, and a first portion of the more concentrated black liquor which is extracted from the bottom of the flash tank 34 may flow in line 36 back to the line 32 to slurry the chips. The majority of

the concentrated black liquor from flash tank 34 passes in line 37 to evaporators in a conventional chemical recovery loop for a kraft mill.

After or during addition of the cooking liquor, the temperature of the slurry is raised to cooking temperature which is about 160°C (150-170°C). Ultimately the chips are typically washed in the bottom of the digester 13 with the wash liquor introduced in line 21, whether an MCC®, EMCC®, or a LO-SOLIDS™ digester is utilized, and the pulp produced is withdrawn in line 39 from adjacent the bottom of the digester 13.

FIGURE 2 schematically illustrates a second form of the invention in which the teachings of the invention are employed with a conventional two vessel hydraulic KAMYR® continuous digester system. In this embodiment structures comparable to those in the FIGURE 1 embodiment are shown by the same reference numeral.

In the FIGURE 2 embodiment the conventional upper and lower extraction screens correspond to the first and second extraction screens 17, 18 according to the present invention. The first spent (sulphurous) liquor withdrawn in conduit 19 is used to -- as in the FIGURE 1 embodiment -- treat the chips prior to cooking, and therefore is introduced into the bottom of the impregnation vessel 11 as indicated generally at 40 in FIGURE 2 -- or in the recirculation line 41 between the top 15 of the digester 13 and the bottom of the impregnation vessel 11, typically right before the heaters 42, or -- alternatively or in addition -- after the heaters 42, as illustrated at 43 in FIGURE 2. A conventional separating device -- shown schematically at 44 in FIGURE 2 -- such as a screen assembly, or alternatively a "stilling well", or a conventional top separator, is used to separate some of the slurring liquid from the introduced chips to be fed to the line 41.

In the FIGURE 2 embodiment at least some of the second spent liquor (black liquor) removed via screen 18 into conduit 20 is used to slurry the chips. In the embodiment illustrated in FIGURE 2 some of the black liquor in line 20 passes to the flash tanks 22, 22' and this concentrated black liquor is then passed to evaporators and to other conventional chemical recovery system components. However some of the black liquor -- in line 45 -- is used to slurry the chips, for example being introduced into the recirculation loop 46 associated with a high pressure transfer device (feeder) 47, as indicated at 48 in FIGURE 2. The high pressure transfer device 47 and loop 46 associated therewith are conventional in two vessel hydraulic systems for feeding presteamed chips in line 10 to the top of the impregnation vessel 11, and the black liquor introduced at 48 is introduced in the recirculatory line 49 from the top of the impregnation vessel 11 to the high pressure pump 50 associated with the high pressure feeder 47.

FIGURE 2 also illustrates a conventional steaming system for producing the steamed chips, which are slurried before passing into conduit 10 and before being introduced to the top of impregnation vessel 11. FIGURE 2 illustrates a pressurized chip bin 51 with a chip meter 52, low pressure feeder 53, horizontal steaming vessel 54, and vessel -- chute -- 55 in which a liquid level is established for liquid that will slurry the steamed chips discharged from horizontal steaming vessel 54.

In the FIGURE 2 embodiment, a valve 56 may be provided, if desired, between the first and second conduits 19, 20, to make minor adjustments in the amount of spent liquor flowing in each of the conduits 19, 20 if more liquor is needed in one conduit than the other. The valve 56 is controlled automatically as is conventional.

FIGURE 3 illustrates a system similar to that in FIGURE 2 and the same components are illustrated by the same reference numerals. In this embodiment, however, there is a countercurrent liquid flow in the top of the digester 13, as indicated by the arrow 57.

5 A bottom circulation screen illustrated schematically at 58 acts as a top separator in FIGURE 3. In this case, then, the "first screen" for withdrawing the first spent liquor (sulphurous liquor) is either the trim screen, illustrated schematically at 59, or the bottom circulation screen (e. g. 58), or a combination of both, both screens 58, 59 being

10 conventional in a two vessel hydraulic system, and associated with the recirculation line 41, and having the conventional pumps 60, 61, respectively, associated with screens 58, 59. Therefore in this embodiment the sulphurous liquor is returned to the bottom of the impregnation vessel 11, to flow upwardly therein, by the conventional

15 recirculation line 41.

FIGURE 4 illustrates the application of the teachings of the invention to a conventional single vessel hydraulic digester system. The FIGURE 4 system is very similar to that of FIGURE 2, and comparable components to the FIGURE 2 embodiment are shown by

20 the same reference numeral, except that there is no impregnation vessel.

In the FIGURE 4 embodiment, a conventional cooking circulation loop 65, including an upper screen set 66, is associated with the digester 13 above the first and second extraction screens 17,

25 18, but below top separator 44. A second cooking recirculatory loop 67, with associated screens 68, also may be provided. In the embodiment of FIGURE 4 the bulk of the impregnation of the chips with cooking liquor takes place in the transfer line 12 and adjacent the top 15 of the digester 13, while normally cooking takes place from

30 about the level of screen 66 down to the extraction screens 17, 18. In

the FIGURE 4 embodiment the first spent liquor (sulphurous liquor) in conduit 19 may be introduced into the chips in the transfer line 12, as indicated at reference numeral 70 in FIGURE 4, while the second spent liquor (black liquor) in line 45 may be introduced into the
5 conduit 71 associated with the slurring vessel/chute 55 which supplies slurried steamed chips to the high pressure feeder 47.

Alternatively, in a single vessel hydraulic system as seen in FIGURE 4 the strong (first) spent liquor may pass counter-currently in situ as in the counter-current mode at the top of the digester 13 in
10 FIGURE 3. In this case an extraction must be taken from one of the upper digester screens in FIGURE 4 so that a counter-current flow of liquor results below the screen, yielding a higher sulfidity liquor during the early stages of cooking. The extraction from the upper screen would then typically be taken to one or more flash tanks, and
15 to conventional chemical recovery.

The sulphur content of the sulphurous liquid in conduit 19 may be enhanced by using green liquor as a source of sulfide. Green liquor is an aqueous solution of primarily sodium carbonate and sodium sulfide. In conventional practice the carbonate is causticized
20 to NaOH to produce white liquor. The sulfide in green liquor can perform the same function as sulfide of the first spent liquor in line 19. Green liquor may be added to either of the first or second spent liquors in lines 19, 20 to enhance sulfidity, although typically any green liquor added would be added to the first spent liquor in line 19,
25 as illustrated at 73 in FIGURE 4 (green liquor may also be used in the FIGURES 1-3 embodiments too, typically added to line 19 although it could be added elsewhere). When used, the added green liquor volume may be from just above 0 to about 2 m³/ton of pulp.

While the embodiments illustrated in FIGURES 2 through 4
30 illustrate a number of different embodiments it is to be understood

that they are only exemplary and that the teachings of the invention in which two different spent liquor streams having effective alkali and Na₂S concentrations which both differ by at least 25% (and preferably by at least 50%) are utilized, can be applied to almost any
5 conventional continuous digester system.

In a single extraction black liquor recirculation described in the prior art the sulfide concentration is diluted by the combined extraction of spent cooking liquor and washing liquor. However in the present "double-extraction" process the two liquors are separated
10 and the stronger liquor is not diluted by wash liquor. For example, for cooking systems with white liquor having typical values of 140 g/l active alkali (at least 100 g/l) and about 35% sulfidity (typically at least about 25% sulfidity, although split sulfidity streams can be used) the relative sulfide concentrations of the two different liquors is
15 at least 25%, and typically more on the order of about 4:1. One particular example, where the white liquor has 140 g/l active alkali and 35% sulfidity, is provided in Table I below. In Table I what is referred to as "strong" liquor corresponds to the first spent liquor in line 19 in the exemplary embodiments of FIGURES 1 through 4,
20 while what is described as "weak" black liquor is the second spent liquor in conduit 20 illustrated in the drawings and as described above.

Table I

Comparison of Sulfide Concentrations
of Extracted Liquors

5 Assume white liquor sulfidity is 35% and active alkali is 140
g/l.
 Assume weak liquor extracted contains 30% of the total volume
of added white liquor, which is typical for MCC® and EMCC® style
10 digesters.

Components of Extracted Liquor (m ³ /ton of wood)	<u>Prior Art Single Extraction</u>	<u>Dual Extraction of Invention</u>	
		<u>Weak</u>	<u>Strong</u>
White Liquor	2.0	0.6	1.4
Wash Liquor	<u>1.0</u>	<u>1.0</u>	<u>0.0</u>
20 Total Extracted Liquor	3.0	1.6	1.4
Na ₂ S Concentration in Extracted Liquor (g/l)	32.7	18.4	49.0

25 Utilizing the teachings of the present invention it is also
possible to simplify the steaming/slurrying system associated with
the digester 13 and/or impregnation vessel 11. FIGURE 5
schematically shows a conventional prior art system, similar to that
illustrated in FIGURE 2, in which a pressurized chip bin 51, chip
30 meter 52, low pressure feeder 53, horizontal steaming vessel 54, and
slurrying vessel/chute 55 are associated with the high pressure feeder
47 to steam and slurry the chips. The use of the steaming vessel 54
typically results in the temperature at the top of the impregnation
vessel 11 being above 100°C, usually about 120°C, and the low

pressure feeder 53 is necessary to isolate the significantly different pressures of the chip bin 51 and chip meter 52 from the steaming vessel 54. However according to the present invention, a lower temperature can be held at the top of the impregnation vessel 11.

5 Thus the feed/slurrying system illustrated in FIGURE 6 can be utilized, in which just the chip bin 51', chip meter 52, and slurrying vessel/chute 55 may be utilized. If the temperature in the top of the impregnation vessel 11 is slightly below 100°C, which is possible in some instances (although not all), the chips are presteamed to only
10 about 100°C in the unpressurized chip bin 51' [slightly different than the pressurized chip bin 51, and simpler].

It will thus be seen that according to the present invention an advantageous method and system are provided for optimizing the production of kraft pulp. Utilizing the method and apparatus of the
15 invention it is possible to provide a more selective cook, with the potential to cook to a lower kappa (easily below 20).

While the invention has been described in connection with what is presently considered to be the most practical and preferred embodiment, it is to be understood that the invention is not to be
20 limited to the disclosed embodiment, but on the contrary, is intended to cover various modifications and equivalent arrangements included within the spirit and scope of the appended claims.

WHAT IS CLAIMED IS:

- 1 1. A method of continuously kraft cooking comminuted
2 cellululosic fibrous material utilizing an upright continuous digester
3 having first and second extraction screens, a top, and a bottom,
4 comprising the steps of continuously:
5 (a) feeding comminuted cellululosic fibrous material slurry to the
6 top of the digester;
7 (b) cooking the material in the digester as it passes
8 downwardly therein, at a cooking temperature of about 150-170°C,
9 producing spent liquor during cooking while digesting the material;
10 (c) using the first extraction screen, withdrawing a first spent
11 liquor from the digester having a first amount of effective alkali and
12 a first Na₂S concentration;
13 (d) using the second extraction screen, withdrawing a second
14 spent liquor from the digester having a second amount of effective
15 alkali and a second Na₂S concentration, each of which are at least
16 25% less than said first amount of effective alkali and first Na₂S
17 concentration;
18 (e) combining at least some of the first spent liquor with the
19 material prior to step (b) to enhance the amount of sulfur present at
20 the beginning of step (b); and
21 (f) withdrawing pulp from the bottom of the digester.

- 1 2. A method as recited in claim 1 wherein step (c) is practiced
2 to extract as the first spent liquor a liquor having an effective alkali
3 concentration of about 10-50 g/l and an Na₂S concentration of greater
4 than about 35 g/l.

1 3. A method as recited in claim 2 wherein step (d) is practiced
2 to extract as the second spent liquor a liquor having an effective
3 alkali concentration of about 5-20 g/l, and an Na₂S concentration of
4 less than about 20 g/l.

1 4. A method as recited in claim 2 wherein the digester
2 comprises a second vessel in a two vessel hydraulic continuous
3 digester system, also including a first, impregnation, vessel; and
4 wherein step (e) is practiced to introduce the first spent liquor into
5 the bottom of the impregnation vessel to flow counter-currently to the
6 material therein.

1 5. A method as recited in claim 2 wherein the digester
2 comprises a single vessel hydraulic digester, and wherein step (e) is
3 practiced to introduce the first liquor into the slurry prior to the
4 practice of step (a).

1 6. A method as recited in claim 2 wherein step (c) is further
2 practiced to extract the first liquor having a temperature of about
3 140-170°C and in an amount of about 2-6 m³/ton of wood, and
4 wherein the second liquor has effective alkali and Na₂S
5 concentrations of at least 50% less than those of the first liquor.

1 7. A method as recited in claim 3 wherein step (d) is further
2 practiced to extract the second liquor having a temperature of about
3 120-160°C and in an amount of about 2-6 m³/ton of wood.

1 8. A method as recited in claim 2 comprising the further steps
2 of (g) flashing the second spent liquor to produce steam and more
3 concentrated second spent liquor, and then (h) using the more

4 concentrated second spent liquor to slurry the comminuted cellulosic
5 fibrous material prior to step (b).

1 9. A method as recited in claim 8 wherein a high pressure
2 transfer device, having a feed circulation loop, feeds slurry to the top
3 of the digester; and wherein step (h) is practiced to introduce the
4 more concentrated second spent liquor into contact with the material
5 in the feed circulation loop of the high pressure transfer device.

1 10. A method as recited in claim 2 comprising the further step
2 of supplementing the first spent liquor with just above 0 to about 2
3 m³/ton of pulp of green liquor.

1 11. A method of continuously digesting comminuted cellulosic
2 fibrous material to produce cellulose pulp comprising the steps of
3 substantially consecutively and continuously:

4 (a) slurrying the material with liquor;

5 (b) treating the material with a first sulphurous liquor having
6 an effective alkali concentration of about 10-50 g/l and a Na₂S
7 concentration of at least about 35 g/l;

8 (c) cooking the material with cooking liquor having an effective
9 alkali concentration of over 100 g/l and a sulfidity of at least about
10 25% at a cooking temperature of about 150-170°C to produce pulp;

11 (d) separating the first sulphurous liquor from the pulp;

12 (e) separating a second liquor from the pulp having a different
13 effective alkali concentration and Na₂S concentration than the first
14 liquor; and

15 (f) washing the pulp.

1 12. A method as recited in claim 11 wherein step (a) is
2 practiced, at least in part, using the second liquor from step (e).

1 13. A method as recited in claim 11 wherein step (d) is further
2 practiced to extract the first liquor having a temperature of about
3 140-170°C and in an amount of about 2-6 m³/ton of wood, and with
4 an Na₂S concentration of about 40-60 g/l.

1 14. A method as recited in claim 13 wherein step (e) is further
2 practiced to extract the second liquor having a temperature of about
3 120-160°C and in an amount of about 2-6 m³/ton of wood.

1 15. A method as recited in claim 11 wherein step (e) is
2 practiced to extract as the second liquor a liquor having an effective
3 alkali concentration of about 5-20 g/l, and less than the effective
4 alkali concentration of the first liquor, and having an Na₂S
5 concentration of less than about 20 g/l.

1 16. A continuous digester system comprising:
2 an upright digester vessel having a top and a bottom;
3 a chip slurry feed inlet adjacent said top of said vessel;
4 a chip feed system connected to said chip feed inlet;
5 a pulp outlet adjacent said bottom of said vessel;
6 a separating device adjacent the top of said vessel for
7 separating some liquor from chips fed into said chip feed inlet and
8 returning it to said chip feed system;
9 at least one upper screen in said vessel distinct from said
10 separating device;
11 a first extraction screen in said vessel below said at least one
12 upper screen, and for extracting a first spent liquor;

13 a second extraction screen in said vessel below said first
14 extraction screen and for extracting a second spent liquor distinct
15 from said first spent liquor; and

16 a first conduit for circulating the first spent liquor to said chip
17 feed system.

1 17. A continuous digester system as recited in claim 16 further
2 comprising:

3 a chip slurring system connected to said chip feed system
4 opposite from said digester; and

5 a second conduit for circulating the second spent liquor from
6 said second extraction screen to said slurring system.

1 18. A continuous digester system as recited in claim 17
2 wherein said second conduit is connected to a flash tank, and
3 comprises a concentrated liquor conduit from said flash tank.

1 19. A continuous digester system as recited in claim 16
2 wherein said chip feed system includes an upright impregnation
3 vessel; and further comprising a steaming and slurring system for
4 feeding chip slurry to the top of said impregnation vessel; said
5 steaming and slurring system consisting essentially of an
6 unpressurized chip bin, a chip feeder, a slurring vessel, and a high
7 pressure feeder.

1 20. A continuous digester system as recited in claim 16
2 wherein said chip feed system includes an upright impregnation
3 vessel; and wherein said first conduit is connected to said
4 impregnation vessel to introduce the first spent liquor into said
5 impregnation vessel to flow countercurrently to chips flowing therein.

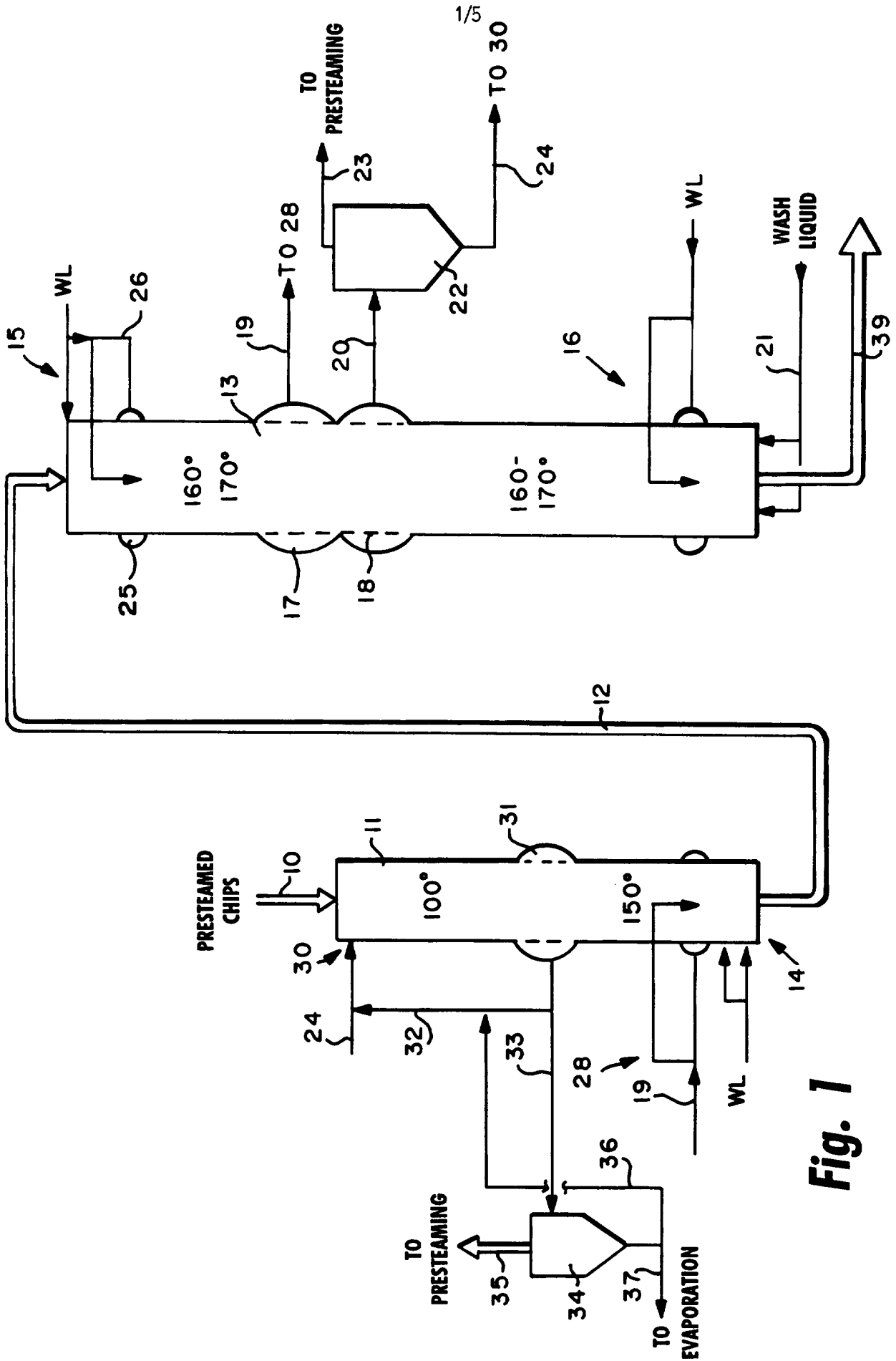

Fig. 1

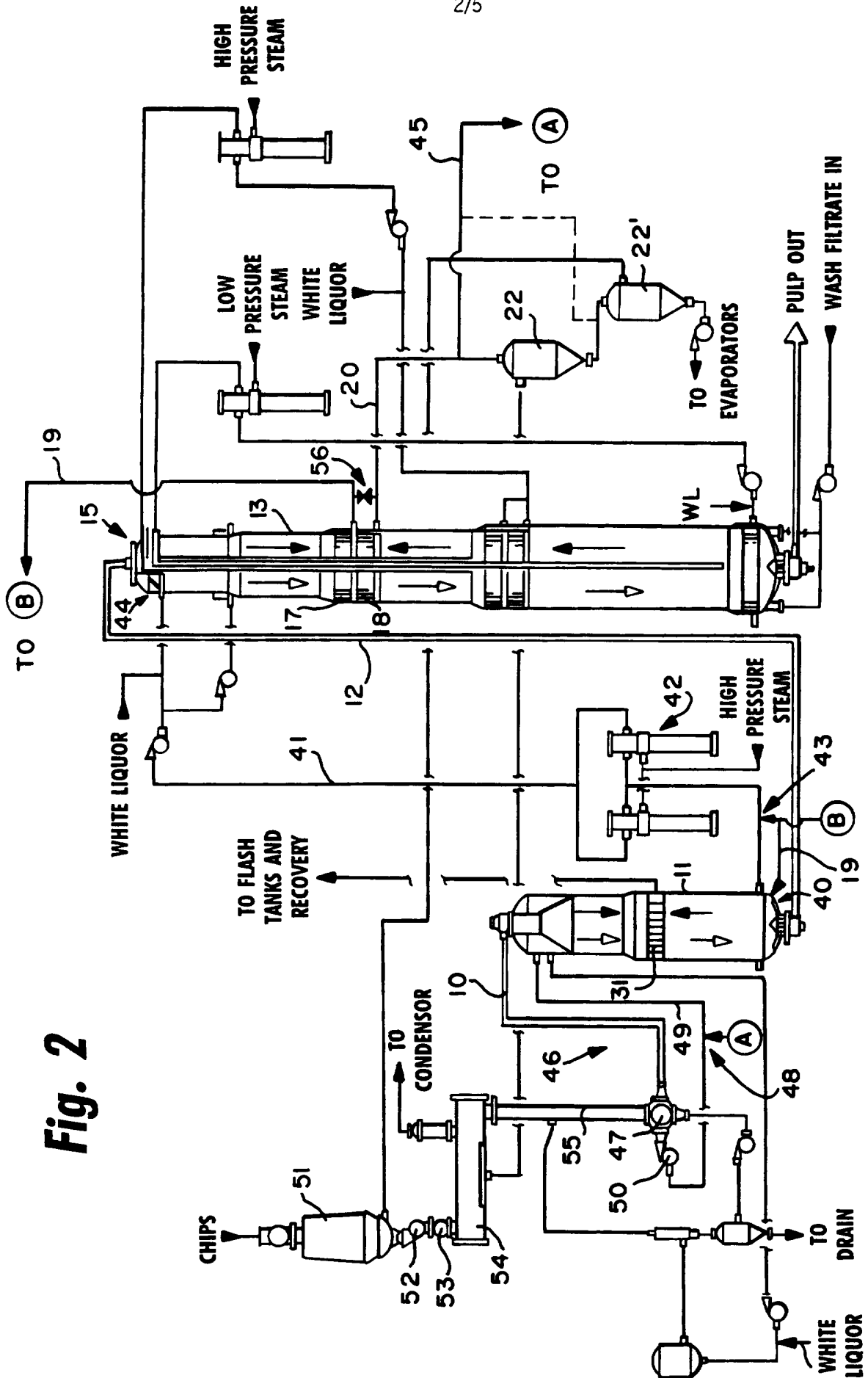
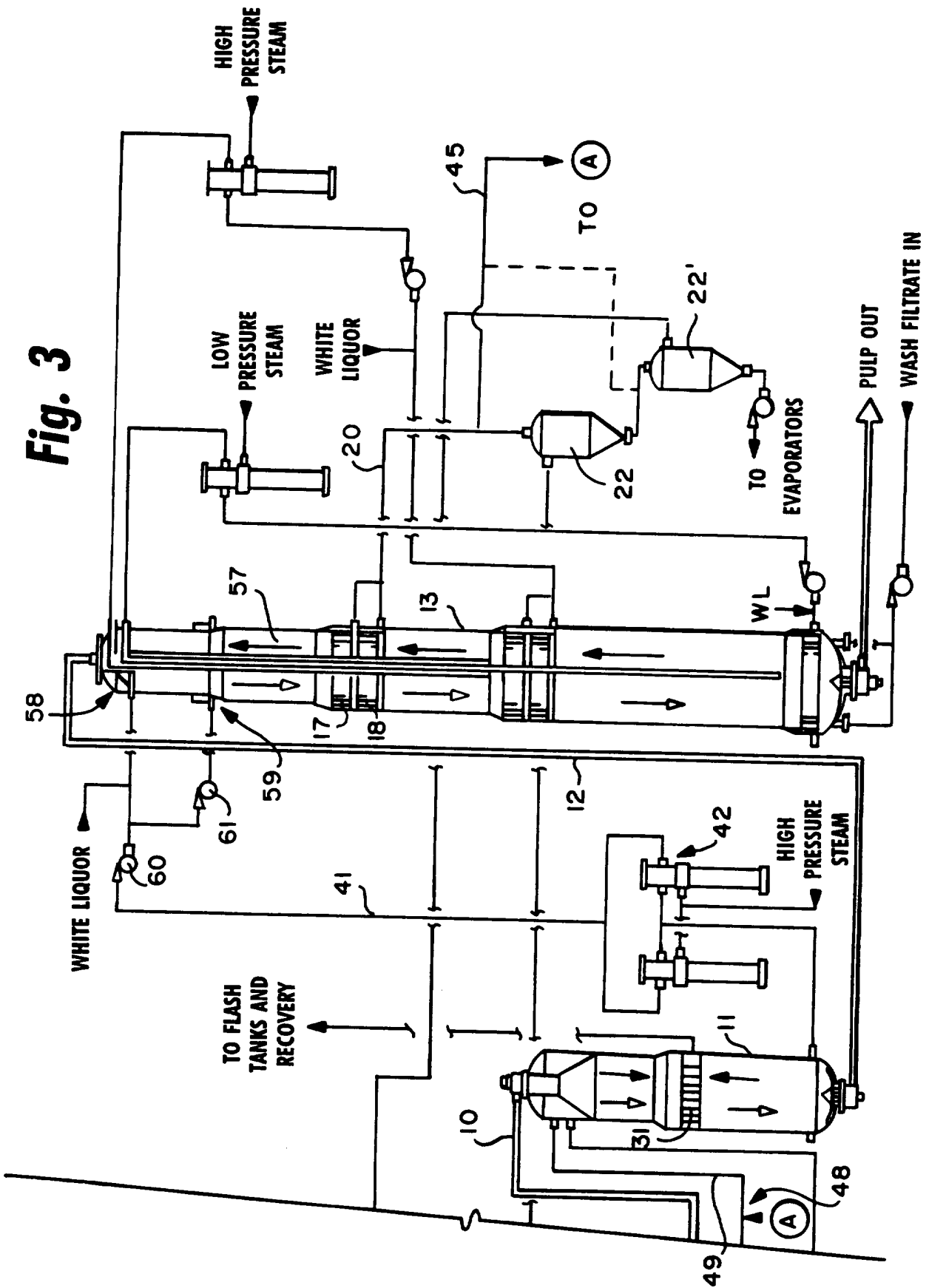

Fig. 2

Fig. 3



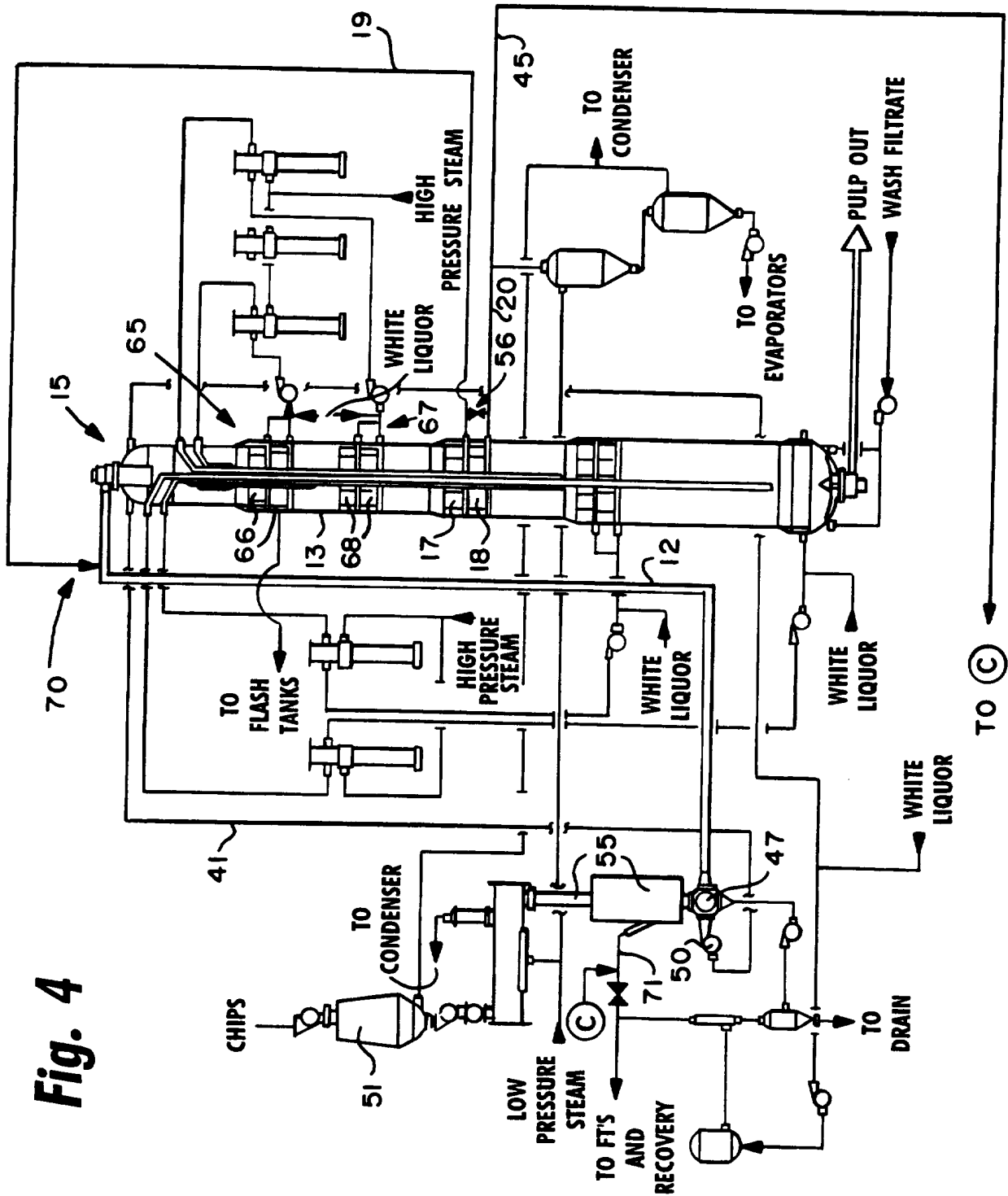

Fig. 4

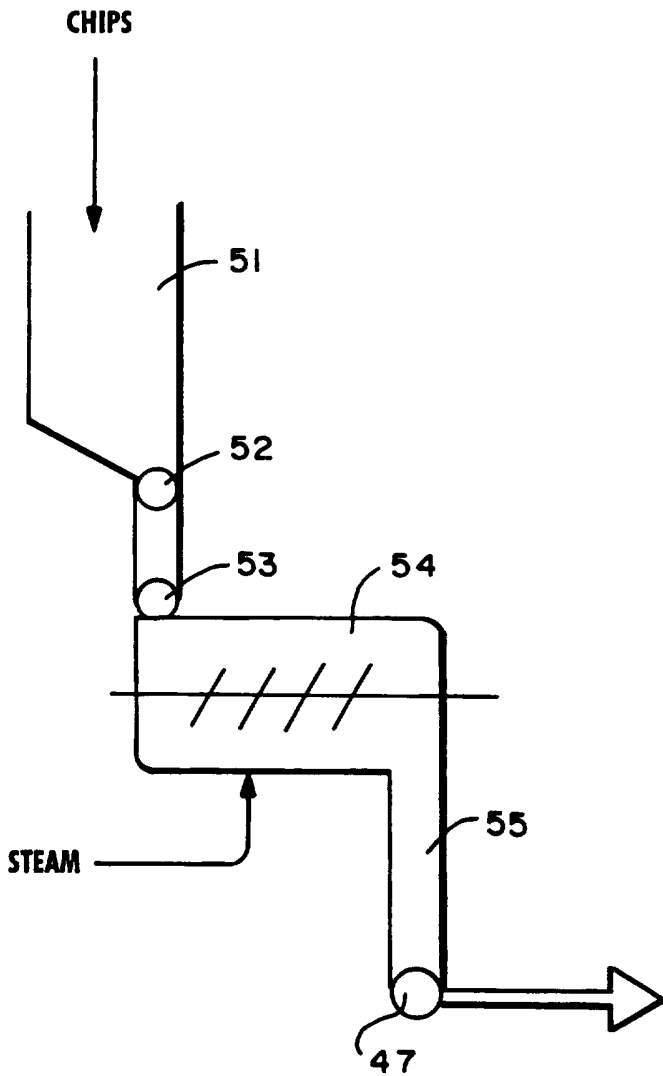

Fig. 5 (Prior Art)

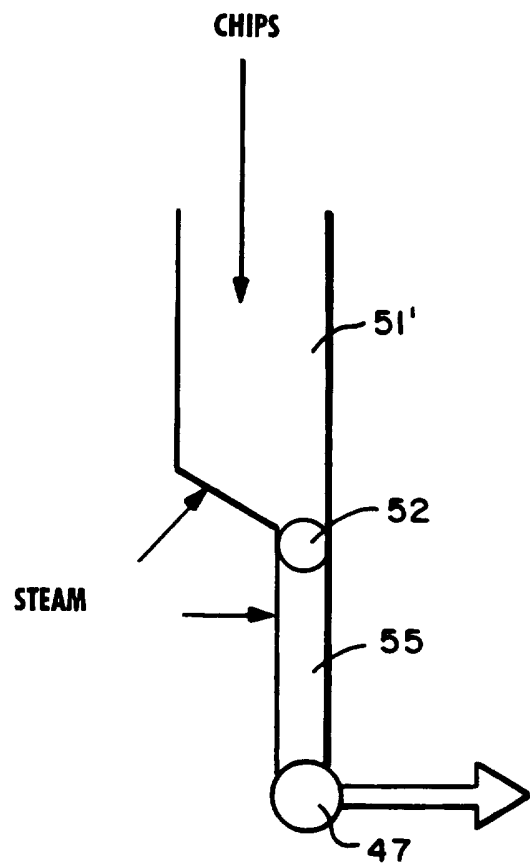

Fig. 6

INTERNATIONAL SEARCH REPORT

Intern. Application No
PCT/US 95/07074

A. CLASSIFICATION OF SUBJECT MATTER
IPC 6 D21C3/02 D21C3/24 D21C7/00

According to International Patent Classification (IPC) or to both national classification and IPC

B. FIELDS SEARCHED

Minimum documentation searched (classification system followed by classification symbols)
IPC 6 D21C

Documentation searched other than minimum documentation to the extent that such documents are included in the fields searched

Electronic data base consulted during the international search (name of data base and, where practical, search terms used)

C. DOCUMENTS CONSIDERED TO BE RELEVANT

Category *	Citation of document, with indication, where appropriate, of the relevant passages	Relevant to claim No.
X	EP,A,0 477 059 (KAMYR AB) 25 March 1992 see column 2, line 42 - column 3, line 11; figure 1	16-18
A	---	1
A	EP,A,0 517 689 (KAMYR INC) 9 December 1992 see page 5, line 39 - line 48	1,11-15
A	EP,A,0 476 230 (KAMYR INC) 25 March 1992 see the whole document	1,16-20

Further documents are listed in the continuation of box C.

Patent family members are listed in annex.

* Special categories of cited documents :

- "A" document defining the general state of the art which is not considered to be of particular relevance
- "E" earlier document but published on or after the international filing date
- "L" document which may throw doubts on priority claim(s) or which is cited to establish the publication date of another citation or other special reason (as specified)
- "O" document referring to an oral disclosure, use, exhibition or other means
- "P" document published prior to the international filing date but later than the priority date claimed

- "T" later document published after the international filing date or priority date and not in conflict with the application but cited to understand the principle or theory underlying the invention
- "X" document of particular relevance; the claimed invention cannot be considered novel or cannot be considered to involve an inventive step when the document is taken alone
- "Y" document of particular relevance; the claimed invention cannot be considered to involve an inventive step when the document is combined with one or more other such documents, such combination being obvious to a person skilled in the art.
- "&" document member of the same patent family

Date of the actual completion of the international search

20 October 1995

Date of mailing of the international search report

31. 10. 95

Name and mailing address of the ISA

European Patent Office, P.B. 5818 Patentlaan 2
NL - 2280 HV Rijswijk
Tel. (+31-70) 340-2040, Tx. 31 651 epo nl,
Fax: (+31-70) 340-3016

Authorized officer

Bernardo Noriega, F

INTERNATIONAL SEARCH REPORT

International Application No
PCT/US 95/07074

Patent document cited in search report	Publication date	Patent family member(s)	Publication date
EP-A-0477059	25-03-92	AT-T- 125010	15-07-95
		CA-A- 2050818	21-03-92
		DE-D- 69111165	17-08-95
		JP-A- 5132882	28-05-93

EP-A-0517689	09-12-92	JP-A- 5163690	29-06-93
		US-A- 5326433	05-07-94
		AU-B- 643117	04-11-93
		AU-A- 1091192	11-03-93
		AU-A- 1508992	11-03-93
		AU-B- 5310194	03-03-94
		EP-A- 0532491	17-03-93
		JP-A- 5237344	17-09-93
		US-A- 5234546	10-08-93

EP-A-0476230	25-03-92	AU-B- 647129	17-03-94
		AU-B- 7830591	19-03-92
		CA-A- 2037717	18-03-92
		JP-A- 4300378	23-10-92
		US-A- 5328564	12-07-94
