

No. 755,271.

PATENTED MAR. 22, 1904.

J. F. BURKHARDT.
GATE.

APPLICATION FILED DEC. 11, 1903.

NO MODEL.

2 SHEETS—SHEET 1.

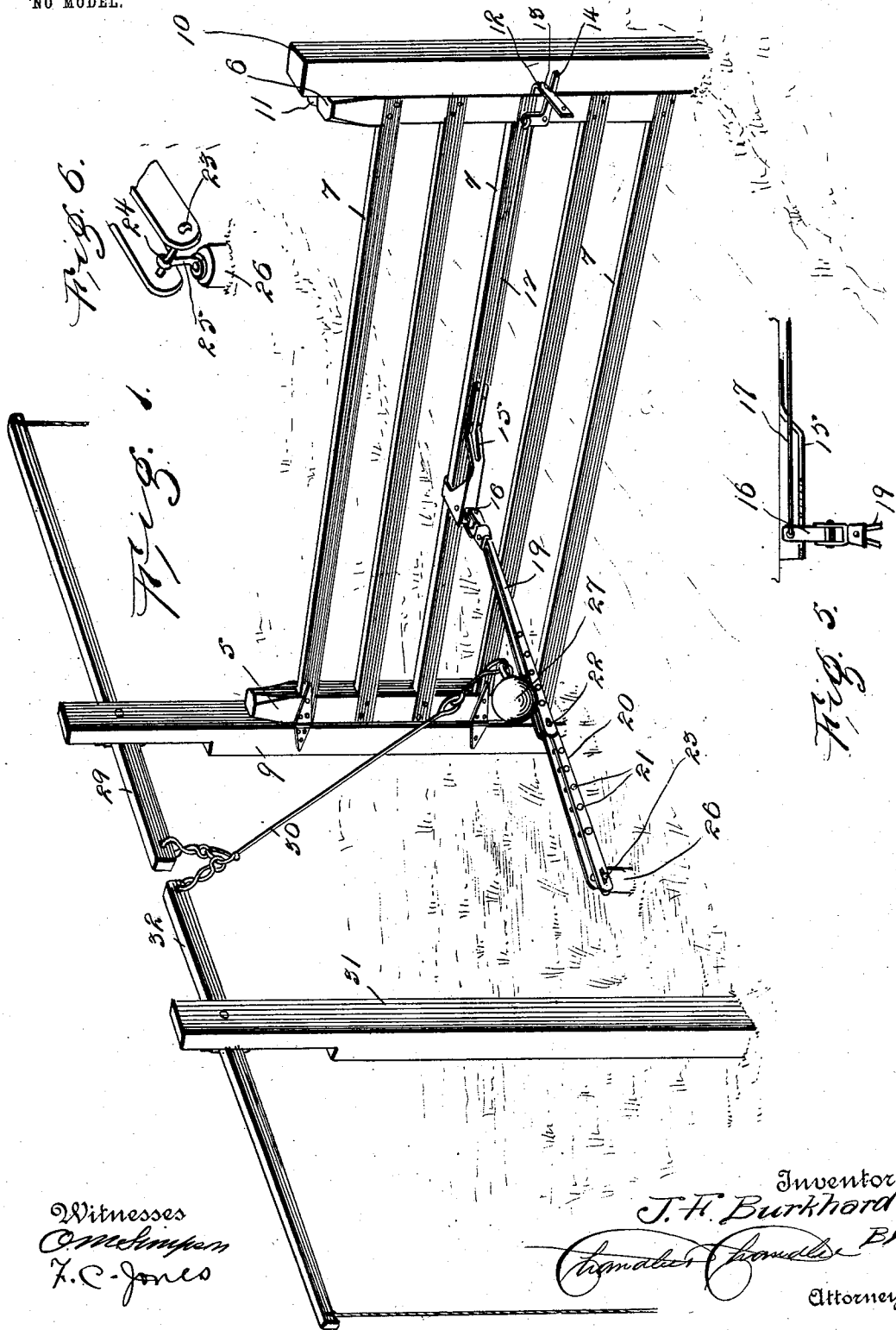

Witnesses
Ormsby
F. C. Jones

Inventor
J. F. Burkhardt
Charles J. ... BY
Attorneys

No. 755,271.

PATENTED MAR. 22, 1904.

J. F. BURKHARDT.
GATE.

APPLICATION FILED DEC. 11, 1903.

2 SHEETS—SHEET 2.

NO MODEL.

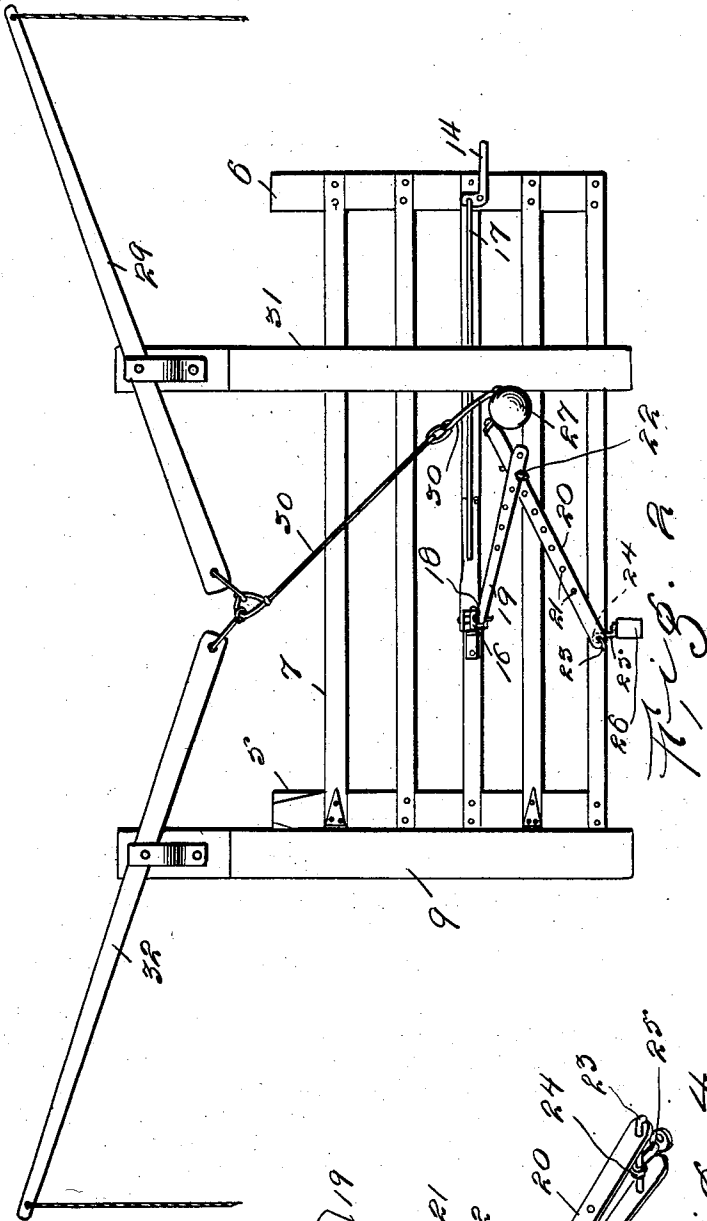

Fig. 3.

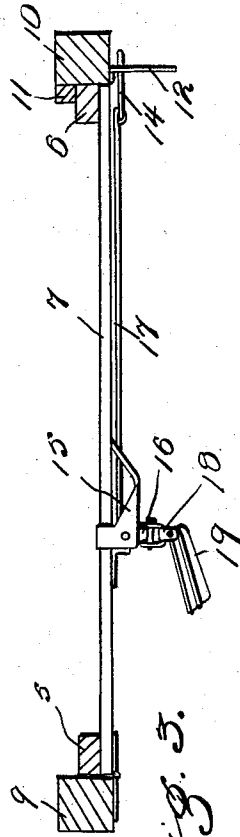

Fig. 5.

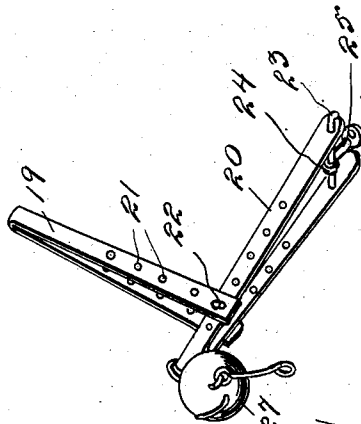

Fig. 4.

Witnesses
W. Simpson
F. C. Jones

Inventor
J. F. Burkhardt

James *James*
Attorneys

UNITED STATES PATENT OFFICE.

JOHN F. BURKHARDT, OF SAN ANTONIO, TEXAS.

GATE.

SPECIFICATION forming part of Letters Patent No. 755,271, dated March 22, 1904.

Application filed December 11, 1903. Serial No. 184,713. (No model.)

To all whom it may concern:

Be it known that I, JOHN F. BURKHARDT, a citizen of the United States, residing at San Antonio, in the county of Bexar, State of Texas, have invented certain new and useful Improvements in Gates; and I do hereby declare the following to be a full, clear, and exact description of the invention, such as will enable others skilled in the art to which it appertains to make and use the same.

This invention relates to gates, and more particularly to that class which are adapted to be opened and closed from a distance and without requiring the operator to leave a vehicle in which he may be seated, the object of the invention being to provide a construction wherein the gate will be held securely in closed position and may be easily operated to unlatch it and swing it into open position and which, furthermore, when in open position will not be liable to be accidentally closed.

Other objects and advantages of the invention will be understood from the following description.

In the drawings forming a portion of this specification, and in which like numerals of reference indicate similar parts in the several views, Figure 1 is a perspective view showing the gate in closed position. Fig. 2 is an elevation showing the gate in open position. Fig. 3 is a horizontal section through the gate in closed position, the latch-operating mechanism being shown in plan. Fig. 4 is a detail view of the toggle. Fig. 5 is a top plan view showing a part of the mechanism for actuating the latch. Fig. 6 is a detail perspective view showing the mounting of the toggle-lever upon the fixed support.

Referring now to the drawings, there is shown a gate comprising uprights 5 and 6, having connecting-slats 7, which in the present instance are five in number, although it will be understood that any number may be employed. To the upright 5 are connected hinges 8, which are connected also to a hinge-post 9, which is firmly planted and extends to a height above the said upright. Spaced from the hinge-post 9 is a latch-post 10, having a stop 11, against which the gate closes, said latch-post having also a keeper 12, projecting

at right angles thereto and having a notch 13 in its under side for engagement by an angular latch 14, which is pivoted at its angle to the front face of the upright 6. When this angular latch is swung on its pivot, it moves with one end vertically into and out of engagement with the notch of the keeper-plate.

Attached to one of the rails or slats 7 of the gate is a frame or casing 15, in which is pivoted a horizontally-movable lever 16, having connected to one end a rod 17, which is pivoted to the upwardly-directed member of the angular latch-lever, so that when said lever 16 is swung laterally the rod will be shifted longitudinally to swing the latch-lever into and out of engagement with the notch of the keeper-plate.

Pivoted to the lever 16 at the opposite end from the rod 17 is a clevis 18, which is movable vertically, and to this clevis is pivoted one member 19 of a toggle-lever, comprising also a member 20, pivoted to the first member. The member 19 comprises arms which diverge from the clevis, and the member 20 comprises also arms that diverge from the point of connection with the first member, between which latter the member 20 lies. The members have each a series of transverse perforations 21 therein, which are adapted for interchangeable alinement to receive the pivot-pin 22, that connects the members of the toggle. The divergent ends of the arms of the toggle member 20 are mounted upon a pin 23, which is passed transversely through a head 24, mounted upon a vertical pin 25 on a block 26, so that this member 20 may swing both vertically and laterally. The convergent ends of the arms of the member 20 extend beyond the pin 22, and at their meeting-point is mounted a weight 27, which serves to hold the toggle with its members normally in alinement when the gate is closed, as shown in Fig. 1. The weight is of such size that it will not pass between the arms of the member 19, and thus acts as a stop to limit the pivotal movement of the members.

Pivoted to the upper end of the post 9 is a lever 29, connected by the links 30 with the weight 27, so that when the lever is operated the weight will be raised and the toggle will

be broken, so that it will pull upon the lever 16 and swing it, with the rod 17, toward the free end of the gate, so that the latch-lever will be operated and move from engagement with the keeper-plate. Further movement of the toggle serves to swing the gate open, the lever being so operated as to give to the weight a degree of momentum sufficient to throw it beyond the block 26, when by action of gravity said weight will serve to swing the toggle farther and move the gate until it strikes the post 31. A lever 32 is pivoted to the post 31 and is connected also with the links 30, so that the toggle will be operated by operation of either of the levers. The weight serves to hold the gate against accidental closing; but by operating either lever the weight may be raised and given sufficient momentum to swing it to its closing position beyond the block 16, when by action of gravity it will serve to swing the gate and engage the latch-lever with the keeper-plate.

It will be understood that in practice modifications of the specific construction shown may be made, and any suitable materials and proportions may be used for the various parts without departing from the spirit of the invention.

What is claimed is—

1. The combination with a hinge-post and a latch-post, of a gate hinged to the gate-post, a keeper upon the latch-post, a pivoted latch upon the gate movable into and out of engagement with the keeper-plate when the gate is in closed position, a lever pivoted upon the

gate, connections between the lever and latch, a toggle pivoted at one end to said lever and at its opposite end to a rotatable support, one of the members of the toggle projecting beyond the pivotal connection of the members of the toggle, a weight mounted upon said projecting portion, and a lever connected with said weight and adapted to raise it.

2. The combination with a hinge-post and a latch-post, of a gate hinged to the hinge-post, a keeper-plate upon the latch-post, an angular latch pivoted upon the gate and movable into and out of engagement with the keeper-plate when the gate is in closed position, a lever pivoted upon the gate, a rod connected to said lever and to one end of the angular latch, a clevis pivoted to the lever, a toggle including a member pivoted to the clevis, a rotatable head to which the opposite end of the second member of the toggle is pivoted, one member of the toggle extending beyond its pivotal connection with the other member, a weight carried by said extending portion, a post spaced from the hinged post in the path of opening movement of the gate, and levers pivoted to the last-named post and the hinged post respectively and connected with said weight for raising the latter.

In testimony whereof I affix my signature in presence of two witnesses.

JOHN F. BURKHARDT.

Witnesses:

A. F. KOSSUB,
HENRY KOSUB.