

(19) World Intellectual Property Organization
International Bureau



(43) International Publication Date
2 February 2006 (02.02.2006)

PCT

(10) International Publication Number
WO 2006/010404 A1

(51) International Patent Classification⁷: A47J 31/30,
31/00

Aurisina (TS) (IT). SUGGI LIVERANI, Furio [IT/IT];
Via G. Picciola, 4, I-34123 Trieste (TS) (IT).

(21) International Application Number:
PCT/EP2005/006045

(74) Agent: LUPPI, Luigi; Luppi & Associati S.R.L., Foro
Buonaparte, 68, I-20121 Milano (IT).

(22) International Filing Date: 6 June 2005 (06.06.2005)

(81) Designated States (unless otherwise indicated, for every
kind of national protection available): AE, AG, AL, AM,
AT, AU, AZ, BA, BB, BG, BR, BW, BY, BZ, CA, CH, CN,
CO, CR, CU, CZ, DE, DK, DM, DZ, EC, EE, EG, ES, FI,
GB, GD, GE, GH, GM, HR, HU, ID, IL, IN, IS, JP, KE,
KG, KM, KP, KR, KZ, LC, LK, LR, LS, LT, LU, LV, MA,
MD, MG, MK, MN, MW, MX, MZ, NA, NG, NI, NO, NZ,
OM, PG, PH, PL, PT, RO, RU, SC, SD, SE, SG, SK, SL,
SM, SY, TJ, TM, TN, TR, TT, TZ, UA, UG, US, UZ, VC,
VN, YU, ZA, ZM, ZW.

(25) Filing Language: English

(26) Publication Language: English

(30) Priority Data:
MO2004A000202 30 July 2004 (30.07.2004) IT

(71) Applicant (for all designated States except US): ILLY-
CAFFE' S.P.A. [IT/IT]; Via Flavia, 110, I-34147 Trieste
(TS) (IT).

(84) Designated States (unless otherwise indicated, for every
kind of regional protection available): ARIPO (BW, GH,
GM, KE, LS, MW, MZ, NA, SD, SL, SZ, TZ, UG, ZM,
ZW), Eurasian (AM, AZ, BY, KG, KZ, MD, RU, TJ, TM),
European (AT, BE, BG, CH, CY, CZ, DE, DK, EE, ES, FI,
FR, GB, GR, HU, IE, IS, IT, LT, LU, LG, MC, NL, PL, PT, RO,
SE, SI, SK, TR), OAPI (BF, BJ, CF, CG, CI, CM, GA, GN,
GQ, GW, ML, MR, NE, SN, TD, TG).

(72) Inventors; and

(75) Inventors/Applicants (for US only): NAVARINI, Lu-
ciano [IT/IT]; Via del Monte Cengio, 2/2, I-34127 Trieste
(TS) (IT). MASTROPASQUA, Luca [IT/IT]; Salita dei
Montanelli, 3, I-34123 Trieste (TS) (IT). DELLAPI-
ETRA, Bruno [IT/IT]; Via Sistiana, 104, I-34013 Duino

[Continued on next page]

(54) Title: METHODS AND APPARATUSES FOR OBTAINING BEVERAGES

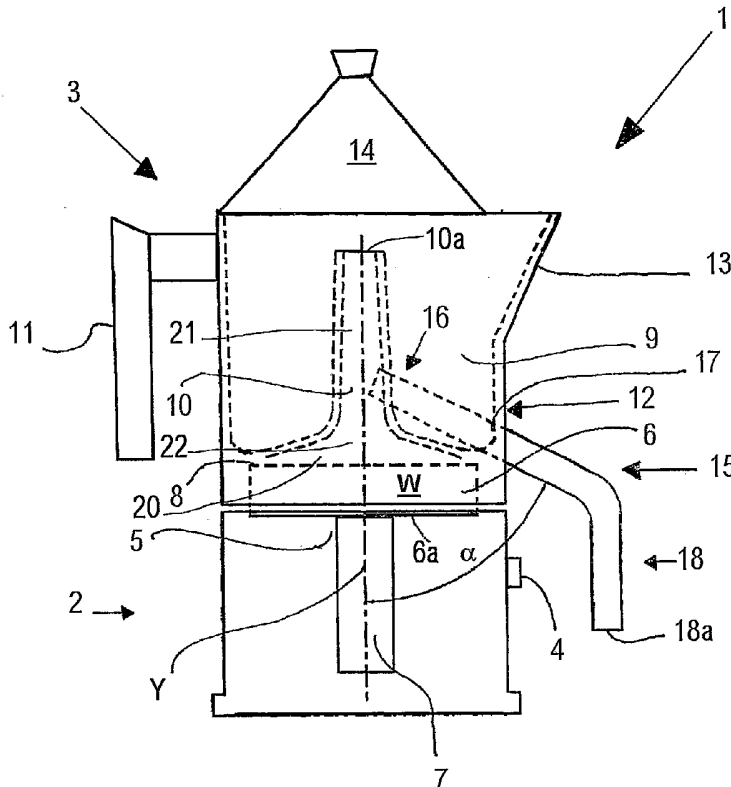

(57) Abstract: An apparatus for preparing a coffee beverage inducing the passage of an extraction fluid through a dose (W) of coffee by heating said fluid, comprises separating means (10, 15) arranged to separate a fraction of said beverage obtained with a prevalently liquid phase of said fluid from a further fraction of said beverage obtained with a prevalently steam phase of said fluid; an apparatus for preparing a coffee beverage by imbibing a dose (W) of coffee with an extraction fluid driven by heating through said dose (W), comprises inhibition means arranged to inhibit said imbibing when said fluid contains a substantial steam phase; a method for obtaining a coffee beverage comprises heating an extraction fluid so as to induce the passage of said extraction fluid through a dose (W) of coffee to obtain said beverage and separating a fraction of said beverage obtained with a prevalently liquid phase of said extraction fluid from a further fraction of said beverage obtained with a prevalently steam phase of said extraction fluid is provided for.

WO 2006/010404 A1

**Declarations under Rule 4.17:**

- as to applicant's entitlement to apply for and be granted a patent (Rule 4.17(ii)) for the following designations AE, AG, AL, AM, AT, AU, AZ, BA, BB, BG, BR, BW, BY, BZ, CA, CH, CN, CO, CR, CU, CZ, DE, DK, DM, DZ, EC, EE, EG, ES, FI, GB, GD, GE, GH, GM, HR, HU, ID, IL, IN, IS, JP, KE, KG, KM, KP, KR, KZ, LC, LK, LR, LS, LT, LU, LV, MA, MD, MG, MK, MN, MW, MX, MZ, NA, NG, NI, NO, NZ, OM, PG, PH, PL, PT, RO, RU, SC, SD, SE, SG, SK, SL, SM, SY, TJ, TM, TN, TR, TT, TZ, UA, UG, UZ, VC, VN, YU, ZA, ZM, ZW, ARIPO patent (BW, GH, GM, KE, LS, MW, MZ, NA, SD, SL, SZ, TZ, UG, ZM, ZW), Eurasian patent (AM, AZ, BY, KG, KZ, MD, RU, TJ, TM), European patent (AT, BE, BG, CH, CY, CZ, DE, DK, EE, ES, FI, FR, GB,

GR, HU, IE, IS, IT, LT, LU, MC, NL, PL, PT, RO, SE, SI, SK, TR), OAPI patent (BF, BJ, CF, CG, CI, CM, GA, GN, GQ, GW, ML, MR, NE, SN, TD, TG)

- as to the applicant's entitlement to claim the priority of the earlier application (Rule 4.17(iii)) for the following designation US
- of inventorship (Rule 4.17(iv)) for US only

Published:

- with international search report

For two-letter codes and other abbreviations, refer to the "Guidance Notes on Codes and Abbreviations" appearing at the beginning of each regular issue of the PCT Gazette.

Methods and apparatuses for obtaining beverages

The invention relates to improved methods and apparatuses for obtaining coffee-based beverages, in particular to be prepared with steam-pressure coffee machines.

Different types of steam-pressure coffee machines are known that are used above all for domestic use, in which the steam generated inside a boiler exerts a pressure that thrusts the water contained in the boiler to pass through a panel of coffee powder, producing to the coffee beverage.

Such steam-pressure coffee machines shall hereinafter be referred to as "Mocha".

The "Mocha" coffee machines in the embodiment shown in Figure E comprise two receptacles that can be hermetically tightened together: a first receptacle acts as a boiler formed in such a way as to contain water to be heated and to be itself heated by a suitable source of energy, and is provided with a relief valve that is suitably calibrated and arranged to prevent the pressure inside the boiler from exceeding a set limit value, a second receptacle that acts as a tank in which the produced beverage is collected.

"Mocha" coffee machines furthermore comprise a filtering funnel interposed between the boiler and the tank and formed in such a way as to receive a set quantity of coffee powder, and a duct for conveying the produced coffee beverage to the tank.

When it is desired to prepare the coffee, a desired quantity of water is poured into the boiler and a desired quantity of coffee is poured into the filtering funnel container and the water of the boiler is heated to take it to boiling point.

As known to those skilled in the art, heating produces increased pressure inside the boiler that thrusts the water therein to pass through the filtering funnel, to go through the coffee powder, thereby imbibing it and giving rise to the coffee beverage, which passes through a second filter provided

at the base of the collection tank, rises up the duct provided inside the tank and emerges at the top part of the duct so collecting in the collection tank.

To generate heating of the water of the boiler, different heat sources can be used, for example the flame of a common gas stove, or an electric plate.

In another type of steam-pressure coffee machines, such as the one shown in Figure F, the collection tank of the coffee beverage is missing and the duct is so shaped as to convey the produced beverage directly to suitable containers, for example one or more cups of a user that can be placed at an outlet portion of the duct.

The duct can be provided with an upper cover shaped in such a way as to identify on a side surface of the duct suitable outlet orifices for the exit of the beverage and be arranged to prevent the beverage, thrust by high pressure, from spurting outside the tank.

In a further type of steam-pressure coffee machines shown in Figure G, there is provided a boiler of the autoclave type inside which the water to be heated is poured, the boiler is electrically heated and following heating into the boiler there is generated steam that pushes the water through a panel of coffee placed on a filter holder from which the produced beverage exits that is collected in suitable containers, for example one or more cups of users, which are located at the filter holder.

The filter holder is shaped in such a way as to be similar to those used in espresso coffee machines in order to simulate the preparation of espresso coffee.

In order for coffee machines to correctly simulate espresso preparation, they have to deliver the coffee beverage in a reasonably short time, so that the temperature in the boiler has values that are significantly greater than 100°C, and these values are reached in a particularly short time.

A drawback of steam-pressure "Mocha" coffee machines like those disclosed above, is that the beverage produced has organoleptic features that are inferior to those of beverages obtained by infusion, or with "espresso" coffee machines, in which extraction is not achieved by steam pressure but by a pump that drives the hot water into contact with the coffee powder.

This is due to the particular temperature and pressure conditions that are generated within such coffee machines during the extraction process.

A further difference between extraction by infusion or pressure percolation achieved with "espresso" coffee machines and the extraction in the steam pressure coffee machines is that in the latest part of the coffee drink is obtained by making water in the form of steam pass through the coffee powder.

In order to overcome this problem, EP0607765 provides for making a coffee machine comprising two distinct boilers into which to pour the water: a first boiler to be placed in contact with a heat source and a second boiler interposed between the first boiler and a filter containing the coffee powder.

When the water of the first boiler is brought to boiling point, it exerts thrust pressure against a piston interposed between the first and the second boiler that forces the water of the second boiler, which is hot but at temperature below boiling point, towards the coffee powder. In this way, the coffee beverage is obtained by imbibing the coffee powder at a temperature between 75° and 95°C.

Providing two different boilers for water, one with water to bring to boiling point and one with water to imbibe the coffee powder, is also known from EP0148982.

The presence of the second boiler for water makes the coffee machines seen above constructionally more complex and above all considerably more bulky than common coffee machines.

Furthermore, such coffee machines consume more energy than
5 common coffee machines because a greater quantity of water has to be heated and they need more time to make the coffee beverage.

Cooling the water and/or the steam that is thrust up from the boiler by the thrust of the pressure generated inside the
10 boiler by the heating of the water is furthermore known, for example from WO94/07400 or IT1245706.

The journey of the water and/or the steam towards the coffee powder is varied in such a way as to provide, before the passage through the coffee powder, the passage through
15 exchanger elements in which the water cools and any steam that may be present condenses.

These solutions nevertheless have numerous drawbacks, in fact the presence of the exchanger element makes these coffee machines more complex and bulkier than common coffee machines.
20 Furthermore, maintenance and cleaning operations are more delicate and require greater time and care than are necessary with common coffee machines.

Such coffee machines furthermore consume more energy than common coffee machines as all the water in the boiler is first
25 heated and is then cooled before coming into contact with the coffee powder.

An object of the invention is to provide improved methods and apparatuses for producing coffee beverages.

Still another object is to provide simple and cheap
30 apparatuses that enable a coffee beverage to be obtained with great organoleptic features.

A further object is to supply simplified methods and apparatuses that enable a coffee beverage to be obtained using water that is not in a steam state.

In a first aspect of the invention a method is provided for obtaining a coffee beverage comprising heating an extraction fluid such as to induce the passage of the extraction fluid through a dose of coffee to obtain said beverage, characterised in that separating a fraction of said beverage obtained with a prevalently liquid phase of said fluid from a further fraction of said beverage obtained with a prevalently steam phase of said fluid is provided for.

In a second aspect of the invention, an apparatus is provided for preparing a coffee beverage by inducing the passage of an extraction fluid through a dose of coffee by heating said fluid, characterised in that it comprises separating means arranged to separate a fraction of said beverage obtained with a prevalently liquid phase of said fluid from a further fraction of said beverage obtained with a prevalently steam phase of said fluid.

In a third aspect of the invention a method is provided for obtaining a coffee beverage comprising heating an extraction fluid to induce said fluid to pass through a dose of coffee, characterised in that this passing through is prevented when said fluid contains a substantial steam phase.

In a fourth aspect of the invention, an apparatus is supplied to prepare a coffee beverage by imbibing a dose of coffee with an extraction fluid driven through said dose by heating, characterised in that it comprises inhibition means arranged to inhibit imbibing when said fluid contains a substantial steam phase.

In an embodiment, said inhibition means comprises stop means arranged to block said heating.

In another embodiment, said inhibition means comprises monitoring means arranged to monitor the heating in such a way as to inhibit the formation of said steam phase in said extraction fluid.

The inhibition means may comprise pressure-adjusting means arranged to adjust the pressure inside a tank containing the fluid by keeping it within a desired range of values; in a particular embodiment, the pressure-adjusting means enables
5 the pressure to be maintained within a range between approximately 0.01 and 5 bar, these values are relative pressure values, assuming that the atmospheric pressure value is 0 bar.

The above-said inhibition means may further comprise
10 temperature-adjusting means for adjusting the temperature inside a tank containing the fluid, keeping it within a desired range of values; in a particular embodiment, the temperature-adjusting means enables the temperature to be kept within a range comprised between approximately 60°C and 120°C.
15 In some embodiments, the inhibition means cooperates with sensor means such as for example level-sensor means, or pressure, or temperature sensor means.

Owing to these aspects of the invention, it is possible to obtain a beverage by imbibing a set quantity of coffee only
20 with water, i.e. preventing the coffee from being imbibed by a fluid containing steam.

The coffee can be in powder or anyway minced form to promote the extraction, or can be in the form of capsules, portions or cartridges containing desired preset quantities of coffee
25 powder.

In this way it is possible to obtain a beverage with high organoleptic features and which is comparable to that obtained with "espresso" coffee machines.

The inhibition means and/or the separating means can be
30 connected, by means of suitable modifications, to a "Mocha" coffee machine of any known type that can thus be used to obtain a high-quality coffee beverage.

The invention will be better understood and implemented with reference to the attached drawings that show an embodiment thereof by way of non-limitative example in which:

Figure 1 is a graph that shows the flow rate [g/min] over time
5 [sec] of a coffee beverage in an extraction procedure that provides for the use of an electric three-cup "Mocha" machine according to the state of the art;

Figure 2 is a graph that shows the flow rate [g/min] over time
10 [sec] of a coffee beverage obtained with three distinct coffee/water ratios in a procedure according to the one in Figure 1;

Figure 3 is a graph that shows the pH values of subsequent fractions of coffee beverage obtained with the procedure according to Figure 1;

15 Figure 4 is a graph that shows the dry residue values [g] of subsequent fractions of coffee beverage obtained with the procedure according to Figure 1;

Figure 5 is a graph that shows the variation of the refraction index in subsequent fractions of coffee beverage obtained with
20 the proceeding according to Figure 1;

Figure 6 is a graph that shows the concentrations of some aromatic substances in the coffee beverage obtained using the procedure according to Figure 1;

Figure 7 is a graph that shows the average excellence
25 indicator of the body of the coffee beverage obtained with the procedure according to Figure 1;

Figure 8 is a lateral schematic section of a "Mocha" coffee machine according to the invention;

Figure 9 is an enlarged detail of Figure 8;

30 Figures E, F and G are schematic representations of different types of known steam-pressure coffee machines.

The graphs set out in Figures 1-7 were obtained using a three-cup electric Mocha machine that has been suitably adapted to facilitate the experimental tests.

By varying the coffee machine used and/or the value of one or more experimental parameters, such as for example the coffee/water ratio, the geometry of the coffee machine, the granulometry and/or the type of coffee powder used, the blend
5 of coffee used, graphs are obtained with point values that are different from those shown in Figures 1-7 but with the same qualitative trend.

The considerations that follow with reference to the attached Figures therefore have general validity and can be extended to
10 experiments using values other than the experimental parameters.

The production dynamics of a coffee beverage with a traditional "Mocha" type coffee machine is explained with the help of the graph in Figure 1 that shows on the Y axis the
15 flow values [g/min] of a coffee beverage produced and on the X axis shows the time [sec], and in which I indicates the average flow calculated on the quantity of beverage collected in the first 6 seconds from the moment of the appearance of the first drop of beverage.

20 In the process of preparation of the coffee beverage 4 phases can be distinguished:

- an imbibing phase, indicated by A in Figure 1, in which the water that is driven towards the coffee powder by an increase in the pressure in the boiler imbibes the
25 initially dry powder and starts extraction of the coffee beverage. This phase is characterised by progressively decreasing values over time of the flow of produced beverage because the water imbibing the coffee powder causes it to swell and compact. In this phase the beverage
30 is extracted with water in liquid state;
- an extraction phase, indicated as B in Figure 1, in which the flow values of the produced beverage remain almost constant over time and in which the beverage is produced

by extraction from the coffee powder with water in liquid state;

- a transition phase, indicated by C in Figure 1, in which the flow values of the produced beverage increase rapidly over time until they reach a maximum value indicated as M and then decrease just as rapidly. In this phase the water changes from liquid state to steam state;
- a further extraction phase, indicated as D in Figure 1, characterised by decreasing flow values of the produced beverage, in which extraction of the coffee beverage occurs through contact between the coffee powder and a mixture of water and steam.

In phase A and B, the coffee beverage is produced by extraction with water, a solid-liquid extraction, whereas, substantially at the maximum flow value M, extraction with a mixture of water and steam, a solid-liquid-steam extraction, starts. This phase is accompanied by gurgling noise that is typical of "Mocha" steam-pressure coffee machines.

The graph in Figure 1 was obtained by pouring into the coffee machine 15 g coffee powder and 150 ml of water in a coffee/water ratio of 1/10 g/ml.

By varying the values of the coffee/water ratio, flow/time curves are obtained with different point values from the one shown in Figure 1, but with unvaried quality, as can be seen from the analysis of the graph in Figure 2 showing the flow of the beverage obtained over time with coffee/water values that are respectively 15/150, 13/150 and 17/150.

The three curves of Figure 2 show an identical qualitative development, the four phases of the preparation process of the beverage can in fact be identified and, in each curve the point M, namely the moment of maximum flow of produced beverage, can be distinctly identified with different coordinates.

By repeating the process of production of the coffee beverage with a three-cup electric "Mocha", suitably modified to facilitate sampling, for each production cycle 10 fractions of coffee beverage of equal weight are taken weighing 11 g that are subjected to different chemical-physical and sensorial analyses in order to investigate their qualities and properties.

An analysis of the aspect of the obtained fractions has shown that the first four fractions are particularly transparent and have an intense reddish brown colour, the subsequent fractions become progressively cloudier and with a less intense colouring and the last two fractions are cloudy and with a very intense dark brown colour and have oily particles dispersed over the surface.

Figures 3 to 5 show respectively the pH values, the dry residue and the refraction index of the different fractions of beverage.

An analysis of the graph in Figure 3 shows that the pH value decreases slightly from the first to the fourth fraction and then increases more decisively from the fifth to the ninth fraction and then suddenly falls at the tenth fraction.

Figure 4 shows the quantity of dry residue [g] in the different fractions of beverage obtained from 25 ml of each fraction. As can be seen from the graph, the quantity of dry residue of each fraction diminishes constantly in the subsequent fractions from the first to the ninth, reaches the minimum value in the ninth fraction and then grows from the ninth to the tenth fraction. Figure 5 shows the trend of the refraction index in the beverage fractions obtained by Illycaffè protocol. The refraction index has values of approximately 1.34 in the first five fractions and reaches the minimum values of approximately 1.334 in the eighth and ninth fractions.

The 10 fractions of beverage obtained were further subjected, after SBSE extraction (Stir Bar Sorptive Extraction), to chromatographic analyses to determine the quantity of the volatile aromatic substances contained therein.

- 5 Figure 6 shows, in terms of area, the quantities of the aromatic substances found in the first and second combined fractions, and in the ninth and tenth combined fractions and the average quantities of these substances in the non-fractionated beverage.
- 10 These values are also set out, if available, in Table 1, respectively in columns 3, 4, 5; column 1 of this table shows the aromatic substances.

COMPOUND	BEVERAGE AVERAGE	FRACTIONS 1+2	FRACTIONS 9+10
2-methylbutanal	684261	3617450	118003
3-methylbutanal	283392	1294385	37559
2,3-butandione	28469	435045	19346
2,3-pentandione	74388	4774112	n.a.
dimethyl sulphide	n.a.	29132	n.a.
2-acetylfuran	185470 7	3099263	66507
2-ethyl-3,5-dimethylpyrazine	102755 3	621688	134626
2-ethyl-3,6-dimethylpyrazine	284796 3	2385983	517735
2,3-diethyl-5-methylpyrazine	806350	596872	272601
3-isobutyl-2-methoxypyrazine	147320	85330	67340
4-hydroxy-2,5-dimethyl-3(2H)-furanone	n.a.	n.a.	n.a.

2(5)-ethyl-4-hydroxy-5(2)-methyl-3(2H)-furanone	n.a.	n.a.	n.a.
3-hydroxy-4,5-dimethyl-2(5H)-furanone	n.a.	n.a.	n.a.
(E)- β -damascenone	193042	58413	135298
Guaiacol	898993	676585	109555
4-ethylguaiacol	347526 1	1192214	1222443
4-vinylguaiacol	118439 80	4685742	7058276
Phenylethanol	89277	101096	n.a.

An analysis of the graph of Figure 6 and/or Table 1 shows that different volatile substances such as for example 2-methylbutanal, 3-methylbutanal, 2,3 butandione are more heavily present in the first two fractions than in the last two fractions of beverage; whereas other different aromatic substances such as for example vinyl-guaiacol and ethyl-guaiacol beta-damascenone are present in greater quantities in the last two fractions of beverage than in the first.

It should therefore be noted that the first two combined fractions of produced coffee beverage have different aromatic substances from those that are present in the last two combined fractions.

The fractions of beverage were finally subjected to an organoleptic analysis with which the overall assessment, or excellence indicator, of the coffee and the appreciation of the beverage was investigated on the basis of different descriptors of the quality of the beverage itself, as for example the body, the excellence indicator of the beverage in the different fractions is shown by way of example in the graph in Figure 7.

The first three fractions of beverage have been judged in a generally very favourable rating, this rating decreases from the fourth fraction onwards; from the sixth fraction onwards foreign aromas (off-flavour), or aromas that are not typical of coffee beverage are noted, in particular, for example, the sixth fraction is characterised by a taste of wet paper, the seventh and eighth by a metal taste, the ninth by an unpleasant heavily metallic taste, the tenth by an extremely unpleasant bleach taste.

10 In general, the appreciation of the fractions is very great when the fractions are obtained by solid-liquid extraction, progressively decreases until it disappears where the fractions are produced by solid-liquid-steam extraction.

For this reason, it is necessary to separate the last 15 fractions of beverage from the others to prevent the organoleptic properties of the entire obtained beverage from being lowered, or it is necessary to maintain the process of preparation of the coffee beverage within conditions of solid-liquid extraction.

20 Figures 8 and 9 show a general model of coffee machine 1 of the "Mocha" steam-pressure type, but the subsequent considerations, when it is not explicitly declared, may apply to any other desired coffee machine of the "Mocha" pressure-steam type, and may furthermore extend, if necessary simple 25 dimensional modifications can be made, to coffee machines suitable for obtaining different quantities of coffee beverage, or a different number of cups of coffee for each operating cycle.

In particular, the ranges specified below for the parameters 30 of Figure 9 were identified following laboratory tests as preferred variation ranges of the above parameters relatively to coffee machines that produce 1 to 12 cups, but with simple scale changes further values of the parameters can be obtained

to use with coffee machines with different productive capacity.

Furthermore, in order to apply the invention, coffee machines can be used to be connected to any source of energy, such as
5 gas stoves, or electric plates, or microwave ovens, or also coffee machines with incorporated electrical resistances.

The coffee machine 1 comprises a boiler 2 into which the water to be heated is poured, which is placed in contact with a source of heat and which is provided with a safety valve 4
10 arranged to prevent pressure inside the boiler 2 exceeding a given maximum value, and an upper portion 3 that is tightened during use onto the boiler 2.

A funnel container 5, comprising a containing cavity 6 that is delimited at the bottom by a filtering surface 6a and inside
15 which a desired quantity of coffee powder indicated by W is poured, and a duct 7 projecting from the containing cavity 6, is inserted inside the boiler 2 in such a way that the duct 7 is projected from the containing cavity 6 towards the bottom of the boiler 2.

The upper portion 3 comprises a lower filtering surface 8, a tank 9 in which the produced coffee beverage is collected and which is connected to the lower surface 8 by a hollow conduit
20 10, a grip 11 for facilitating a user's grasp of the coffee machine 1, a side surface 12 provided with a projecting portion 13 spout shaped through which the beverage is poured,
25 and a removable lid.

The hollow conduit 10 comprises a substantially frustum conical portion 20 arranged on the lower surface 8 and a conveying portion 21 connected to the frustum conical portion
30 20 by a connecting zone 22 have a circular section with a diameter indicated as D in Figure 9 preferably comprised between 3 and 15 mm.

The frustum conical portion 20 conveys the coffee beverage that exits from the lower surface 8 to the conveying portion

21, extending from the connecting zone 22 to an upper surface 10a of the hollow conduit 10, the coffee beverage runs into the hollow conduit 10 and is then discharged through its upper surface 10a. The conveying portion 21 may have a cylindrical shape or a shape that is slightly funnelled upwards.

The hollow conduit 10 has an overall longitudinal extent, defined as the distance between the lower filtering surface 8 and the upper surface 10a, indicated as H in Figure 7, preferably comprised between 10 and 150 mm, and is shaped in such a way as to offer the least possible resistance to the exiting of the beverage obtained by extraction with steam in order to facilitate, as shall be seen below, the separation between the fraction of beverage obtained with a prevalent liquid phase from the fraction obtained with a prevalent steam phase.

In particular, the conduit 10 is provided with an upper surface 10a from which the coffee beverage exits that is obtained with a completely free outlet section, i.e. the portions that partial cover the upper surface 10a are not provided that are on the other hand provided in the state of the art.

Inside the tank 9 a conveying conduit 15 is inserted comprising an end 16 that is inserted inside the conduit 10, a portion 17 that extends partially inside the tank 9 and partially outside it and that is arranged in such a way as to be tilted in relation to a vertical direction Y by an angle α comprised between 0° and 90° , and an outlet portion 18 having an almost vertical extent and terminating with an outlet end 18a.

The end 16 of the conveying conduit 15 can be inserted into the conduit 10 at a distance from the filtering surface 6a indicated by H1 in Figure 9 comprised between 0 and 50 mm.

In particular, when the value of H1 is the same as 0 mm, the conveying conduit 15 is arranged at the same height as the

lower surface 8, thereby terminating in the frustum conical portion 20 and receiving the coffee beverage produced directly by the lower surface 8.

The section of the conveying conduit 15 is almost circular with a diameter, indicated as D_1 in Figure 9, with a value that is preferably comprised between 1 and 10 mm; the tilted portion 17 of the conveying conduit 15 has an extent indicated by L in Figure 9 the value of which is preferably comprised between 0 and 150 mm.

10 In order to prepare a coffee beverage, a suitable quantity of water is poured inside the boiler 2, a suitable quantity of coffee powder is poured into the funnel container 5 that is inserted inside the boiler 2, the upper portion 3 is tightened on the boiler 2 and the coffee machine 1 is then subjected to
15 a heat source.

The water in the boiler 2 is heated, causing a pressure increase that thrusts part of the water of the boiler 2 to rise up through the duct 7 until it comes into contact with the coffee powder, imbibing it and extracting the coffee
20 beverage therefrom, the coffee beverage passes through the lower filtering surface 8, rises up through part of the conduit 10 until it reaches the end 16 at which it leaves the conduit 10, flows through the conveying conduit 15 and is finally discharged through the outlet end 18a into a
25 collection container for containing the fraction of beverage subsequently called "approved", which is located at the outlet end 18a.

Through the effect of the heat and the subsequent increase of pressure and temperature inside the boiler 2, after a certain
30 lapse of time, extraction of the coffee beverage occurs through solid-liquid-steam extraction.

During this extraction phase the flow of produced beverage decreases over time but the thrust pressure increase, in other words the produced beverage is subjected to a thrust pressure

in its ascent in the conduit 10 that is greater than that of the solid-liquid extraction phase, so the beverage produced runs through the entire conduit 10, emerges from the upper surface thereof 10a and is collected in the tank 9.

5 In this way, it is avoided that the fraction of beverage obtained by solid-liquid-steam extraction mixes with the fraction of beverage obtained by solid-liquid extraction and inside the tank 9 a beverage is obtained with inferior organoleptic features, said fraction of beverage being
10 subsequently called as "rejected".

By varying the tilt of the portion 17 of the conveying conduit 15, it is possible to vary the ratio between the fraction of approved beverage and the fraction of rejected beverage collected inside the tank 9.

15 Laboratory tests have indicated an angle comprised between 0° and 90°, preferably comprised between 50° and 85°, in relation to the vertical, as an acceptable tilt value, this value being confirmed as acceptable also with different models of coffee machines on which the laboratory tests were conducted.

20 With the coffee machine 1 disclosed above, it is possible to obtain in a simple and economical manner a coffee beverage with pronounced organoleptic features by simply separating the fraction of beverage with an unpleasant taste from the fraction of beverage with a pleasant taste.

25 Alternatively, the solid-liquid-steam extraction of the coffee beverage for obtaining a coffee beverage with pronounced organoleptic features can be avoided.

In particular, coffee machines can be provided provided with temperature and/or pressure sensors, and/or water level
30 sensors appropriately calibrated and connected to acoustic or visual elements in such a way that when certain values of said parameters are detected, acoustic or visual signals are emitted. In this way, a user is warned that solid-liquid-steam extraction is about to start and can decide whether to

continue this extraction process or arrest it by acting on the heat source to have a beverage with pronounced organoleptic features.

Furthermore, in the electric coffee machines provided with an internal electric resistance, the sensor elements can be connected to on/off switches in such a way that when certain values of said parameters are detected that indicate the start of solid-liquid-steam extraction, the coffee machine is switched off, and production of a beverage with an unpleasant taste is thus automatically avoided.

Alternatively, in the electric coffee machines provided with an internal electric resistance the sensor elements may be connected to control elements for controlling the supplied power, in such a way that the electric power delivered is such as to prevent solid-liquid-steam extraction.

In another embodiment, it is further possible to suitably calibrate the safety valve with which the coffee machines are provided on a set pressure value, so as to prevent steam being generated inside the boiler, in such a way that when the set pressure value is reached in the boiler the safety valve opens to discharge the pressure inside the boiler, warning the user of the advisability of acting on the heat source.

In Table 2 attached below the results of experimental tests on different types of "Mocha" steam-pressure type coffee machines are set out, column 1, loaded with different quantities of coffee and water, column 2. Column 3 shows the quantity of approved beverage [g], columns 4 and 5 respectively show the average refraction index and the pH of the approved beverage, column 6 shows the quantity of rejected beverage [g], columns 7 and 8 respectively show the average refraction index and the pH of the rejected beverage, column 9 shows the residual quantity of water [g] in the boiler.

The results shown in lines 1-4 and 10-12 were obtained with coffee machines of the type schematically represented in

Figures E, and F, modified like the coffee machine in Figure 8, i.e. with coffee machines provided with a beverage separator, the results given in lines 5-9 were obtained with coffee machines of the type schematically shown in Figures E, and G, in which it is provided to stop in different ways the extraction of the coffee beverage, in particular: the results given in lines 5, 6 were obtained with coffee machines provided with level sensors, the results given in line 7 with manual intervention at the start of the solid-liquid-steam extraction phase, the results given in lines 8, 9 by stopping heating upon respective reaching of relative pressure in the boiler 2 amounting to 0.7 and 0.5 bar.

The results shown in lines 1-9 were obtained with a coffee/water ratio value of 0.1, whereas the results of lines 10-12 with a coffee/water ratio value of approximately 0.113.

Type of Mocha	Coffee/water	Approved beverage			Rejected beverage			Residual water
		Weight [g]	RI (30°C)	PH	Weight [g]	RI (30°C)	pH	
TYPE 1	12/120	88.45	1.33981	5.423	3.22	1.33410	na	9.10
TYPE 2	15/150	97.93	1.34000	5.483	28.25	1.33539	6.104	3.27
TYPE 3	15/150	90.35	1.34096	5.426	32.48	1.33491	6.006	2.88
TYPE 4	15/150	65.93	1.34384	5.436	55.07	1.33421	6.171	5.43
TYPE 5	15/150	79.40	1.34257	5.314	na	na	na	46.70
TYPE 6	15/150	66.33	1.34012	5.275	na	na	na	59.30
TYPE 7	10/100	41.00	1.34465	na	33.00	1.33448	na	na

TYPE 8	15/15 0	98.4 7	1.3410 0	5.359	na	na	na	na
TYPE 9	15/15 0	95.0 0	1.3410 1	5.380	na	na	na	na
TYPE 2	17/15 0	86.4 5	1.3414 4	5.376	35.88	1.3348 8	6.07	4.05
TYPE 3	17/15 0	89.3	1.3419 4	5.349	36.5	1.3349 2	5.909	1.00
TYPE 4	17/15 0	71.4	1.3450 6	5.391	18.6	1.3354 4	5.902	18.0

CLAIMS

1. Apparatus for preparing a coffee beverage inducing the passage of an extraction fluid through a dose (W) of coffee by heating said fluid, characterised in that it comprises separating means (10, 15) arranged to separate a fraction of said beverage obtained with a prevalently liquid phase of said fluid from a further fraction of said beverage obtained with a prevalently steam phase of said fluid.
2. Apparatus according to claim 1, wherein said separating means comprises conveying conduit means (15) arranged to convey said fraction to a designated container.
3. Apparatus according to claim 1, or 2, wherein said separating means further comprises conduit means (10) arranged to convey said further fraction to tank means (9) of said apparatus.
4. Apparatus according to claim 2, or according to claim 3 as appended to claim 2, wherein said conveying conduit means (15) comprises a portion (17) arranged at a tilt (α) in relation to a substantially vertical axis (Y) of said conduit means (10).
5. Apparatus according to claim 4, wherein said tilt (α) is comprised between 0° and 90° .
6. Apparatus according to claim 5, wherein said tilt (α) is comprised between 50° and 80° .
7. Apparatus according to any one of claims 4 to 6, wherein said portion (17) has an extent (L) comprised between 0 and 150 mm.
8. Apparatus according to claim 2, or according to any one of claims 4 to 7, wherein said conveying conduit means (15) has a transverse dimension (D1) comprised between 1 and 10 mm.
9. Apparatus according to claim 3, or according to any one of claims 4 to 8, as claim 4 is appended to claim 3,

wherein said conduit means (10) has a longitudinal extent (H) comprised between 10 and 150 mm.

10. Apparatus according to any preceding claim and further comprising containing means (6) arranged to contain said
5 dose of coffee (W).
11. Apparatus according to claim 10, as appended to claim 3, or to any one of claims 4 to 8, as claim 4 is appended to claim 3, or to claim 9 and further comprising filtering means (8) interposed between said containing means (6)
10 and said conduit means (10).
12. Apparatus according to claim 11, as claim 10 is appended to any one of claims 4 to 8, as claim 4 is appended to claim 3, or to claim 9, wherein said conveying conduit means (15) is placed at a distance (H1) from said
15 filtering means (8) comprised between 0 and 50 mm.
13. Apparatus according to claim 3, or according to any one of claims 4 to 8 if claim 4 is appended to claim 3, or according to claim 9, or 11, or 12, or according to claim
20 10 as appended to claim 3, or as appended to any one of claims 4 to 8 if claim 4 is appended to claim 3, or to claim 9, wherein said conduit means (10) comprises a frustum conical portion (20) that receives said coffee beverage from said filtering means (8).
14. Apparatus according to claim 13, wherein said conduit
25 means (10) further comprises an outlet portion (21, 10a) for discharging said beverage into said tank means (9).
15. Apparatus according to claim 14, wherein said conduit
30 means (10) further comprises a connecting portion (22) interposed between said frustum conical portion (20) and said outlet portion (21, 10a) having a longitudinal dimension (D) comprised between 3 and 15 mm.
16. Apparatus according to any one of claims 1 to 15, and further comprising inhibition means arranged to inhibit said passage of said extraction fluid through said dose

(W) of coffee to inhibit the formation of said further fraction of beverage.

- 5 17. Apparatus for preparing a coffee beverage by imbibing a dose (W) of coffee with an extraction fluid taken through said dose (W) by heating, characterised in that it comprises inhibition means arranged to inhibit said imbibing when said fluid contains a substantial steam phase.
- 10 18. Apparatus according to any one of claims 1 to 17, and further comprising further containing means (2) arranged to receive said fluid to be heated.
- 15 19. Apparatus according to claim 18, as appended to claim 16, or 17, wherein said inhibition means comprises temperature sensor means to detect the temperature of said fluid inside said further containing means (2).
- 20 20. Apparatus according to claim 19, wherein said temperature sensor means comprises temperature adjusting means arranged to maintain a desired temperature range inside said further containing means (2).
- 20 21. Apparatus according to claim 20, wherein said temperature adjusting means enables a temperature comprised between approximately 60 °C and 120 °C to be maintained inside said further containing means (2).
- 25 22. Apparatus according to claim 18, as appended to claim 16, or 17, or according to any one of claims 19 to 21, wherein said inhibition means comprises level-sensor means arranged to detect the level of said fluid inside said further containing means (2).
- 30 23. Apparatus according to claim 18, as appended to claim 16, or 17, or according to any one of claims 19 to 22, wherein said inhibition means further comprises pressure sensor means (4) arranged to detect the pressure of said fluid inside said further containing means (2).

- 24.Apparatus according to claim 23, wherein said pressure sensor means comprises safety valve means (4) arranged to maintain pressure values within a set range of values inside said further containing means (2).
- 5 25.Apparatus according to claim 24, wherein said safety valve means (4) enables the corresponding pressure values to be maintained between 0.01 bar and 5 bar inside said further containing means (2).
- 10 26.Apparatus according to any one of claims 16 to 25, wherein said inhibition means cooperates with signalling means arranged to emit warning signals to a user of said apparatus.
- 27.Apparatus according to claim 26, wherein said signalling means comprises acoustic signalling means.
- 15 28.Apparatus according to claim 26, or 27, wherein said signalling means comprises visual signalling means.
- 29.Apparatus according to any one of claims 16 to 28, wherein said inhibition means comprises switch elements arranged to switch on/switch off said apparatus.
- 20 30.Apparatus according to any one of claims 16 to 29, wherein said inhibition means cooperates with power regulating means arranged to suitably regulate the power absorbed by said apparatus.
- 25 31.Apparatus according to any one of claims 1 to 30 and further comprising heat transmitting means arranged to generate said heating.
- 32.Apparatus according to any one of claims 1 to 31 and further comprising electric resistance means arranged to generate said heating.
- 30 33.Apparatus according to any preceding claims, wherein said dose (W) of coffee comprises coffee powder or minced coffee.
- 34.Apparatus according to any one of claims 1 to 33, wherein said dose (W) of coffee comprises capsules, and/or

portions, and/ or cartridges containing desired preset quantities of coffee.

- 5 35. Method for obtaining a coffee beverage comprising heating an extraction fluid so as to induce the passage of said extraction fluid through a dose (W) of coffee to obtain said beverage, characterised in that it is provided for separating a fraction of said beverage obtained with a prevalently liquid phase of said fluid from a further fraction of said beverage obtained with a prevalently steam phase of said fluid.
- 10 36. Method according to claim 35, wherein said separating comprises conveying said fraction to a designated container by means conveying conduit means (15).
- 15 37. Method according to claim 35, or 36, wherein said separating comprises further conveying said further fraction to tank means (9) of an apparatus for making coffee beverages by means of conduit means (10).
- 20 38. Method according to any one of claims 35 to 37, and further comprising inhibiting said passage of said extraction fluid through said dose (W) of coffee to avoid the formation of said further fraction of beverage.
- 25 39. Method for obtaining a coffee beverage comprising heating an extraction fluid to induce said fluid to pass through a dose (W) of coffee, characterised in that inhibiting said passing is provided for when said extraction fluid contains a substantial steam phase.
40. Method according to any one of claims 35 to 39, and further comprising pouring said extraction fluid to be heated into suitable containing means (2).
- 30 41. Method according to claim 40, as appended to claim 38, or 39, wherein said inhibiting comprises detecting the temperature of said fluid inside said containing means (2).

42. Method according to claim 41, wherein said detecting the temperature comprises adjusting the temperature of said extraction fluid inside said containing means (2) within a desired range of values.
- 5 43. Method according to claim 42, wherein said adjusting the temperature comprises maintaining the temperature of said fluid inside said containing means (2) within values comprised between approximately 60 °C and 120 °C.
- 10 44. Method according to claim 40, as appended to claim 38, or 39, or according to claim 41, wherein said inhibiting comprises detecting the level of said fluid inside said containing means (2).
- 15 45. Method according to claim 40, as appended to claim 38, or 39, or according to any one of claims 41 to 44, wherein said inhibiting comprises detecting the pressure of said fluid inside said containing means (2).
- 20 46. Method according to claim 40, as appended to claim 38, or 39, or according to any one of claims 41 to 45, wherein said inhibiting comprises further maintaining the pressure inside said containing means (2) within a desired range of values by safety relief valve means (4).
- 25 47. Method according to claim 46, wherein said further maintaining comprises maintaining the relative pressure in said containing means (2) by means of safety valve means (4) within a range of values comprised between approximately 0.01 bar and 5 bar.
48. Method according to any one of claims 35 to 47, wherein said inhibiting further comprises transmitting warning signals to a user.
- 30 49. Method according to claim 48, wherein said transmitting signals comprises transmitting acoustic signals.
50. Method according to claim 48, or 49, wherein said transmitting signals comprises transmitting visible signals.

51. Method according to any one of claims 35 to 50, wherein said inhibiting further comprises stopping said heating.
52. Method according to any one of claims 35 to 51, wherein said inhibiting further comprises appropriately
5 regulating the power absorbed during said heating.
53. Method according to any one of claims 35 to 52 wherein said heating comprises absorbing heat from electric resistance means arranged to generate said heating.
54. Method according to any one of claims 35 to 53, and
10 further comprising the use of coffee in powder or anyway minced form.
55. Method according to any one of claims 35 to 53, and further comprising the use of capsules, portions or cartridges containing desired preset quantities of coffee
15 powder.

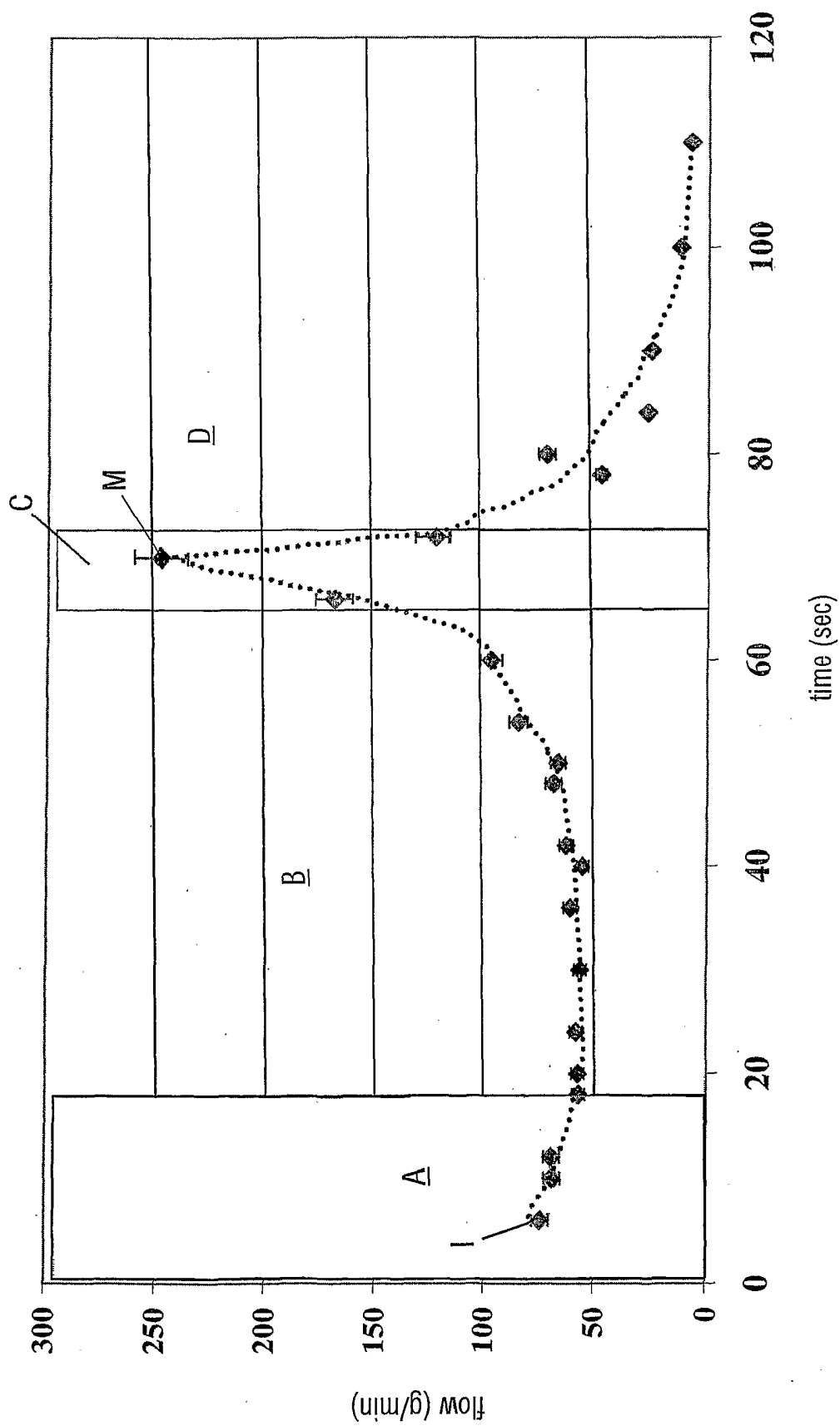

Fig. 1

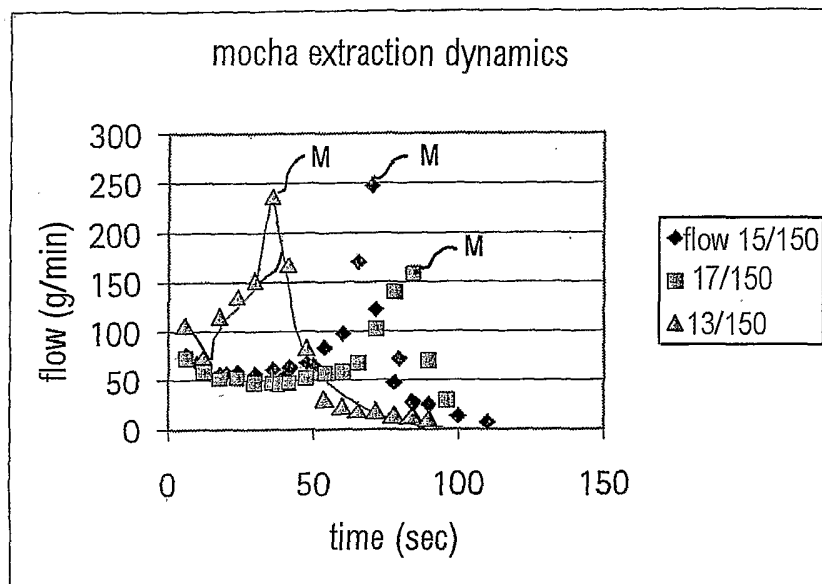

Fig. 2

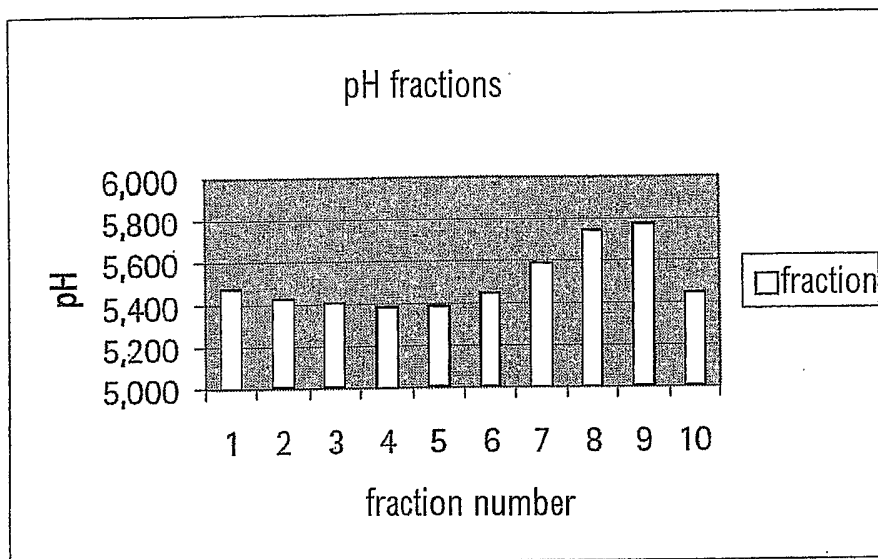

Fig. 3

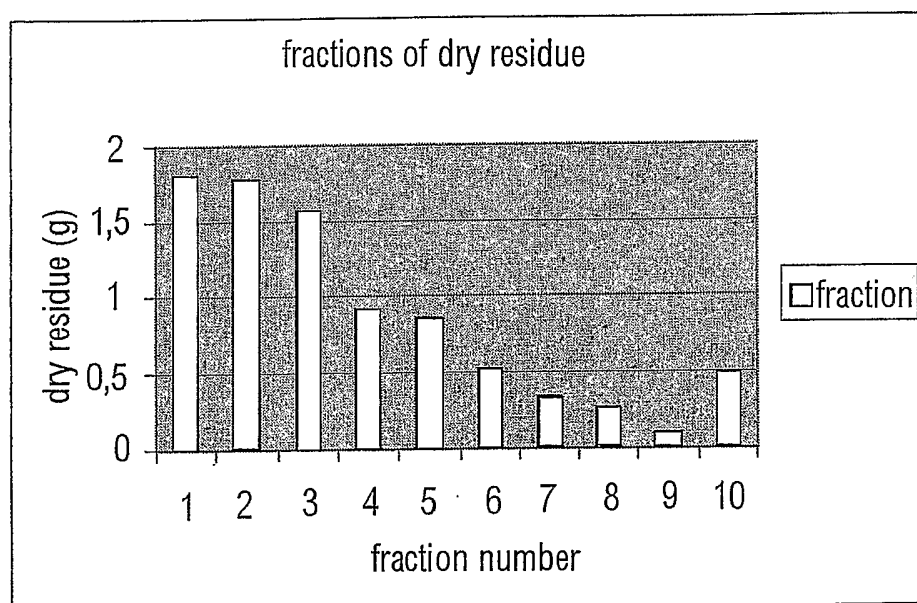

Fig. 4

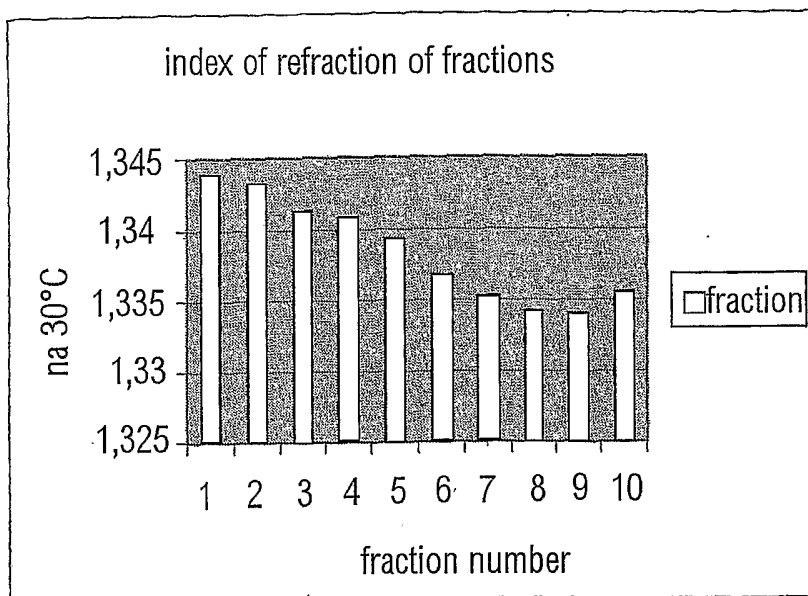

Fig. 5

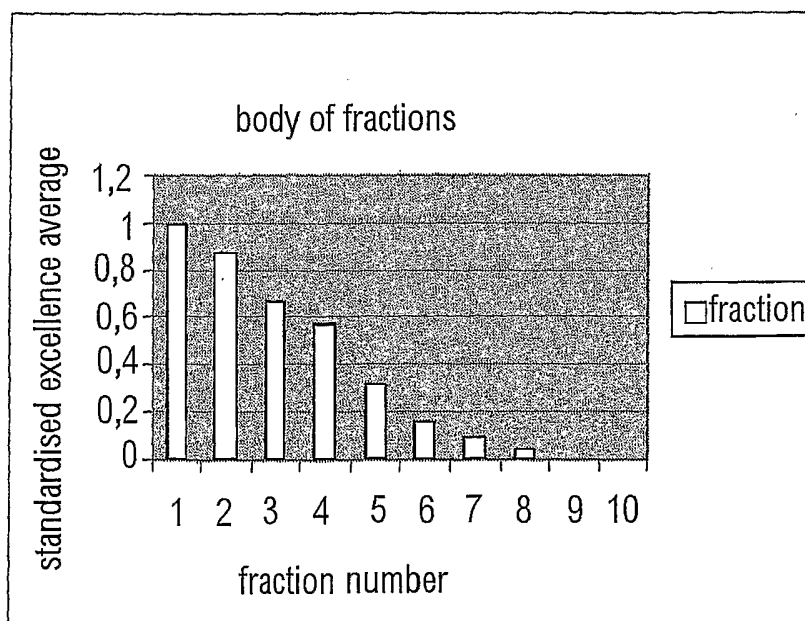

Fig. 7

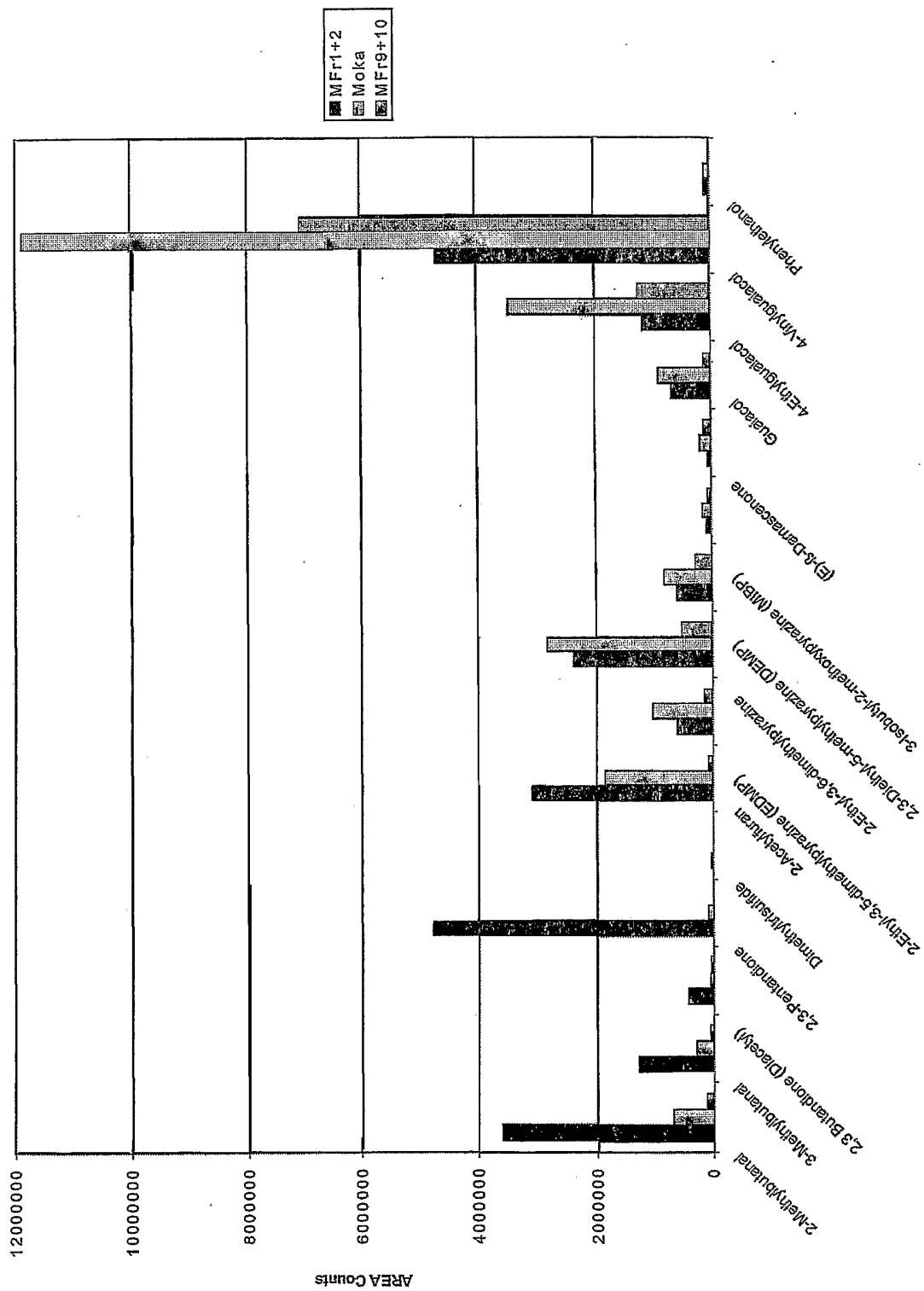

Fig. 6

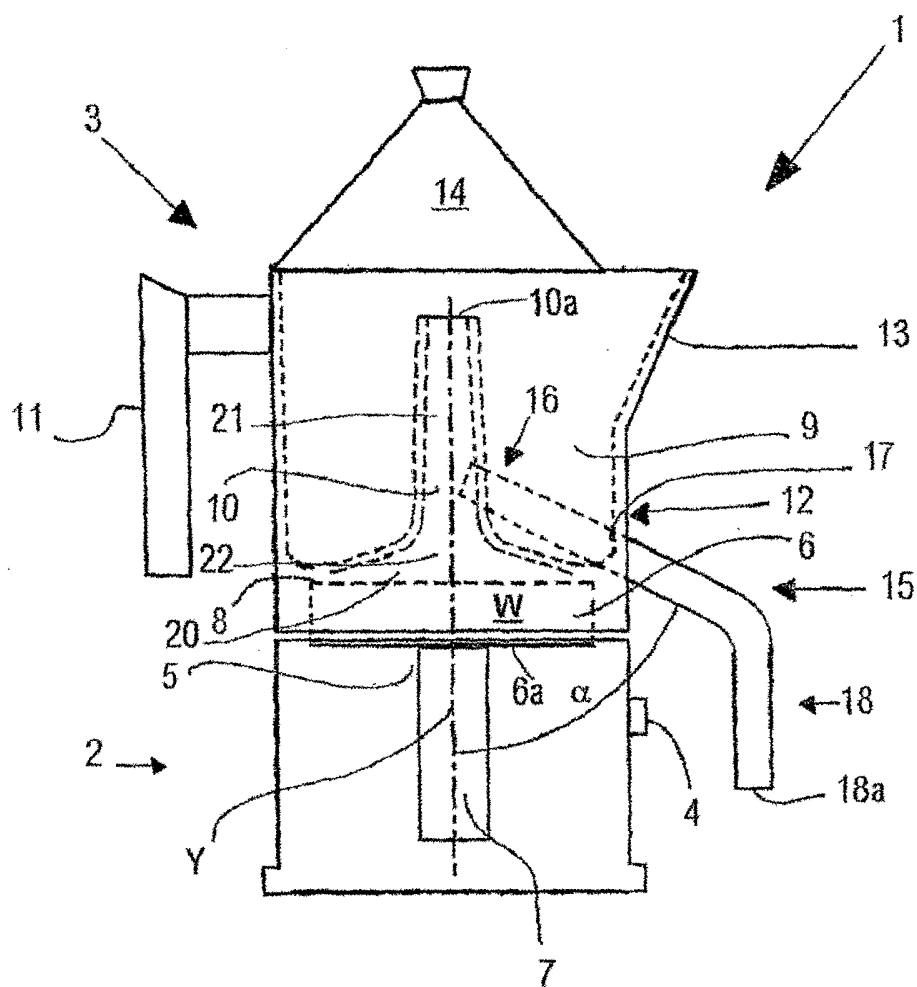

Fig. 8

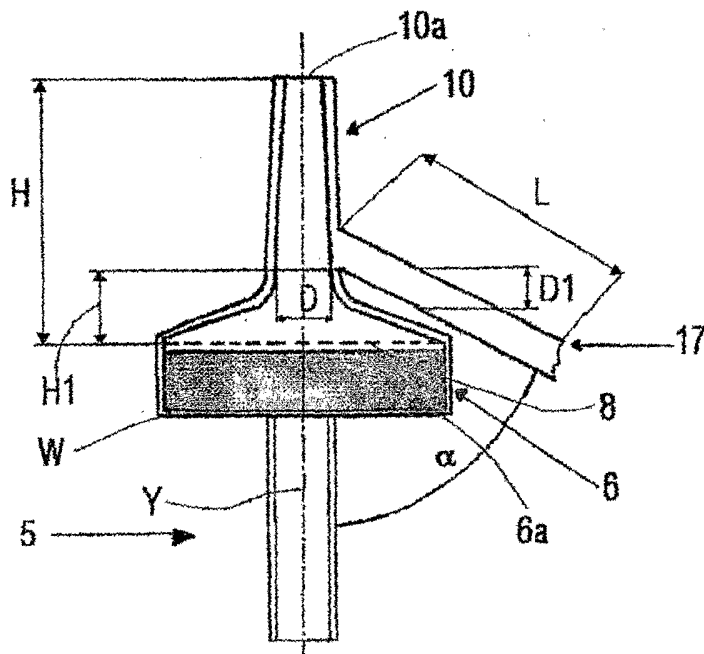

Fig. 9

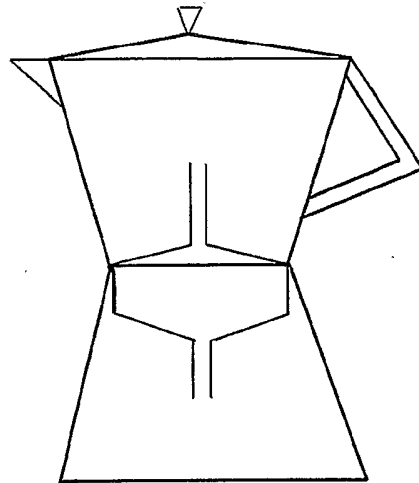

Fig. E

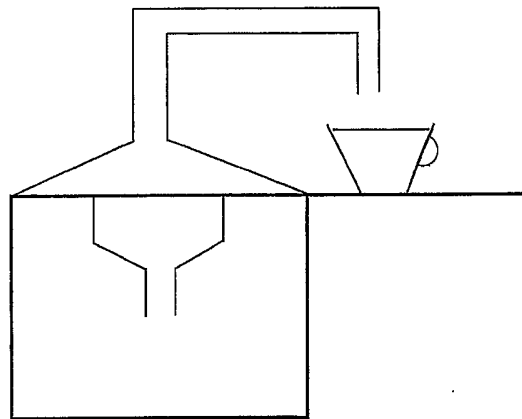

Fig. F

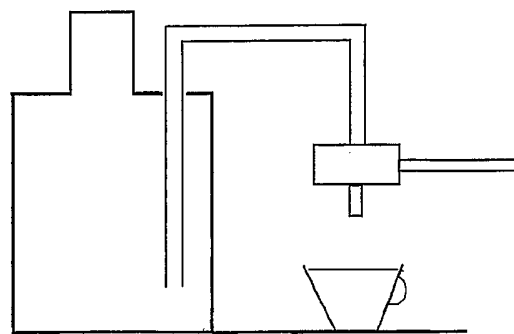

Fig. G

INTERNATIONAL SEARCH REPORT

International Application No
PCT/EP2005/006045

A. CLASSIFICATION OF SUBJECT MATTER IPC 7 A47J31/30 A47J31/00		
According to International Patent Classification (IPC) or to both national classification and IPC		
B. FIELDS SEARCHED		
Minimum documentation searched (classification system followed by classification symbols) IPC 7 A47J		
Documentation searched other than minimum documentation to the extent that such documents are included in the fields searched		
Electronic data base consulted during the international search (name of data base and, where practical, search terms used) EPO-Internal		
C. DOCUMENTS CONSIDERED TO BE RELEVANT		
Category °	Citation of document, with indication, where appropriate, of the relevant passages	Relevant to claim No.
X	US 6 161 469 A (ROLLA ET AL) 19 December 2000 (2000-12-19) column 3, lines 42-58; figure 3 column 5, line 26 - column 6, line 15 -----	1-3, 8-15, 35-37
X	WO 94/07400 A (PARIENTI, RAOUL; SANCHEZ, ISABELLE) 14 April 1994 (1994-04-14) pages 1-4; figures 1,2 -----	17-25, 31-34, 39-48, 53-55
X	FR 2 347 014 A (KOUTEK SRL) 4 November 1977 (1977-11-04) page 2, line 12 - page 4; figure 1 -----	17-25, 31-34, 39-48, 53-55
<input type="checkbox"/> Further documents are listed in the continuation of box C.		
<input checked="" type="checkbox"/> Patent family members are listed in annex.		
° Special categories of cited documents :		
"A" document defining the general state of the art which is not considered to be of particular relevance	"T" later document published after the international filing date or priority date and not in conflict with the application but cited to understand the principle or theory underlying the invention	
"E" earlier document but published on or after the international filing date	"X" document of particular relevance; the claimed invention cannot be considered novel or cannot be considered to involve an inventive step when the document is taken alone	
"L" document which may throw doubts on priority claim(s) or which is cited to establish the publication date of another citation or other special reason (as specified)	"Y" document of particular relevance; the claimed invention cannot be considered to involve an inventive step when the document is combined with one or more other such documents, such combination being obvious to a person skilled in the art.	
"O" document referring to an oral disclosure, use, exhibition or other means	"&" document member of the same patent family	
"P" document published prior to the international filing date but later than the priority date claimed		
Date of the actual completion of the international search <p style="text-align: center; font-weight: bold;">4 November 2005</p>	Date of mailing of the international search report <p style="text-align: center; font-weight: bold;">03. JAN. 2006</p>	
Name and mailing address of the ISA European Patent Office, P.B. 5818 Patentlaan 2 NL - 2280 HV Rijswijk Tel. (+31-70) 340-2040, Tx. 31 651 epo nl, Fax: (+31-70) 340-3016	Authorized officer <p style="text-align: center; font-weight: bold;">Van Bastelaere, T</p>	

INTERNATIONAL SEARCH REPORT

International application No.
PCT/EP2005/006045

Box II Observations where certain claims were found unsearchable (Continuation of item 2 of first sheet)

This International Search Report has not been established in respect of certain claims under Article 17(2)(a) for the following reasons:

1. Claims Nos.:
because they relate to subject matter not required to be searched by this Authority, namely:

2. Claims Nos.:
because they relate to parts of the International Application that do not comply with the prescribed requirements to such an extent that no meaningful International Search can be carried out, specifically:

3. Claims Nos.:
because they are dependent claims and are not drafted in accordance with the second and third sentences of Rule 6.4(a).

Box III Observations where unity of invention is lacking (Continuation of item 3 of first sheet)

This International Searching Authority found multiple inventions in this international application, as follows:

see additional sheet

1. As all required additional search fees were timely paid by the applicant, this International Search Report covers all searchable claims.
2. As all searchable claims could be searched without effort justifying an additional fee, this Authority did not invite payment of any additional fee.
3. As only some of the required additional search fees were timely paid by the applicant, this International Search Report covers only those claims for which fees were paid, specifically claims Nos.:
4. No required additional search fees were timely paid by the applicant. Consequently, this International Search Report is restricted to the invention first mentioned in the claims; it is covered by claims Nos.:

Remark on Protest

- The additional search fees were accompanied by the applicant's protest.
- No protest accompanied the payment of additional search fees.

FURTHER INFORMATION CONTINUED FROM PCT/ISA/ 210

This International Searching Authority found multiple (groups of) inventions in this international application, as follows:

1. claims: 1-16,35-38

Apparatus for preparing a coffee beverage, with separating means

2. claims: claims 17-34, 39-55

Apparatus for preparing a coffee beverage with inhibition means

INTERNATIONAL SEARCH REPORT

Information on patent family members

International Application No

PCT/EP2005/006045

Patent document cited in search report		Publication date		Patent family member(s)	Publication date
US 6161469	A	19-12-2000	IT	GR980007 A1	24-05-2000
WO 9407400	A	14-04-1994	DE	69231806 D1	31-05-2001
			DE	69231806 T2	08-11-2001
			EP	0684777 A1	06-12-1995
			ES	2157907 T3	01-09-2001
FR 2347014	A	04-11-1977	NONE		