

R. W. HOW & C. E. PATTERSON.

Improvement in Machine for Crozing and Dressing the
Inside of Pails, &c.

No. 132,401.

Patented Oct. 22, 1872.

Fig. 1.

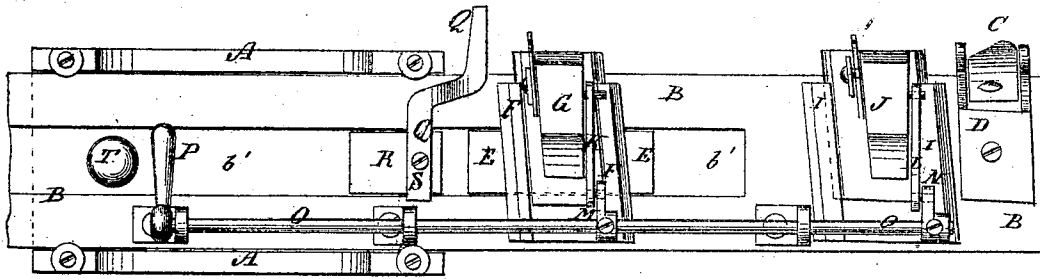

Fig. 2.

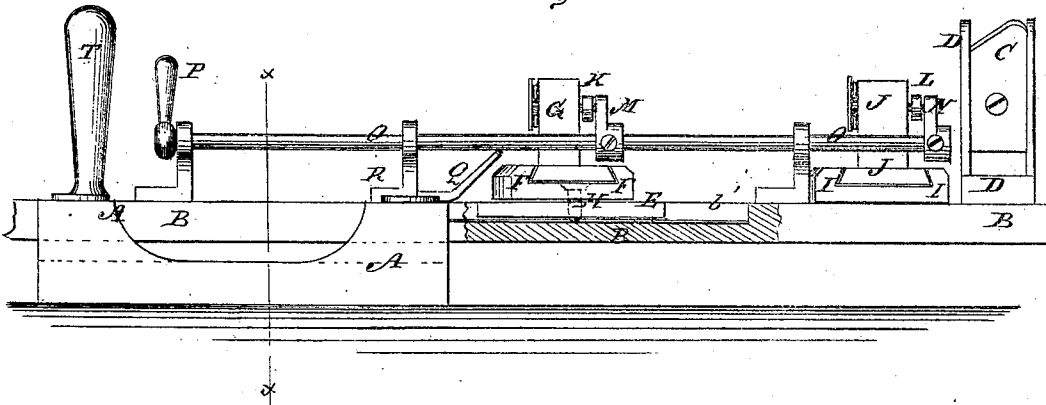
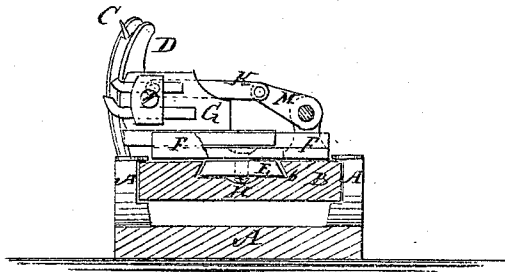

Fig. 3.



Witnesses:

Chas. Nida.
Alex. F. Roberts.

Inventor:

Richard W. How.
Clarence E. Patterson.

PER *Munnell*
Attorneys.

UNITED STATES PATENT OFFICE.

RICHARD W. HOW AND CLARENCE E. PATTERSON, OF BROOKLYN, N. Y.

IMPROVEMENT IN MACHINES FOR CROZING AND DRESSING THE INSIDES OF PAILS, &c.

Specification forming part of Letters Patent No. 132,401, dated October 22, 1872.

To all whom it may concern:

Be it known that we, RICHARD W. HOW and CLARENCE E. PATTERSON, of Brooklyn, in the county of Kings and State of New York, have invented a new and useful Improvement in Turning-Out Slide of Pail-and-Keg Lathes, of which the following is a specification:

Figure 1 is a top view of a part of a pail-and-keg lathe illustrating our invention. Fig. 2 is a side view of the same, part being broken away to show the construction. Fig. 3 is a detail cross-section of the same taken through the line *xx*, Fig. 2, and part being broken away to show the construction.

Similar letters of reference indicate corresponding parts.

Our invention has for its object to furnish an improved turning-out slide of pail-and-keg lathe, which shall be simple in construction, convenient in use, and easily adjusted for different-sized pails and kegs; and it consists in the construction and combination of various parts of the lathe, as hereinafter more fully described.

A represents the stand in which the slide B is held. C is the turning-out knife, which is attached to the head D, which is attached to the forward end of the slide B. In the upper side of the slide B is formed a wide dovetailed groove, *b'*, to receive the block E, to which is attached the bed F of the movable crozing-head G. The block E is dovetailed to fit into the groove *b'*. The bed F is secured to the block E, and both are secured in place in the groove *b* of the slide B by a set-screw, H, which passes through the bed F and block E, and draws the bed F down upon the slide B, the block E being pressed up against the inclined sides of the groove *b*, as shown in Figs. 2 and 3. The upper side of the bed F has a dovetailed groove formed in it to receive the crozing-head G, as shown in Figs. 1 and 2. I is the bed of the crozing-head J. The bed I and the head J are exactly like the bed F and head G. To the sides of the crozing-heads G and J are pivoted the ends of the connecting-bars K and L, the other ends of which are pivoted to the ends of the short crank-arms M and N. The crank-arms M and N are placed

upon the shaft O, and are secured to it adjustably by set-screws, as shown in Figs. 1 and 2. The shaft O is placed longitudinally with the slide B, and works in bearings attached to said slide B.

By this construction, by turning the shaft O in one direction, the crozing-heads G J will both be moved forward into a working position; and by turning the said shaft O in the other direction the said crozing-heads will both be drawn back to allow the slide B to be withdrawn from the pail or keg. The shaft O is turned by a crank-arm, P, attached to its end.

Q is a stop-arm, secured to the dove-tailed block R placed in the dovetailed groove *b'* of the slide B, and adjustably secured in place by a set-screw, S, in the same manner as the block E and bed F of the adjustable crozing-head G are secured. The arm Q projects into such a position that the ends of the staves of the pail or keg, when the slide B is moved forward into the said pail or keg, will strike against it and stop the said slide in the proper position for the crozing-knives to operate upon the staves, the adjustable crozing-heads having been previously adjusted in proper position. T represents a handle for adjusting the slide B in the stand A.

Having thus described our invention, we claim as new and desire to secure by Letters Patent—

1. The means for moving forward into a working position the crozing-heads G J and allowing of the withdrawal of sliding carrier B, consisting of the block E, beds F I, pivoted connecting-bars K L, crank-arms M N, and shaft O, constructed and arranged as described.

2. The combination of the stop-arm Q, dove-tailed block R, and set-screw S, with slide B having a dovetailed slot formed in it, and with the adjustable crozing-heads G J, substantially as herein shown and described, and for the purpose set forth.

RICHARD W. HOW.

CLARENCE E. PATTERSON.

Witnesses:

BRYAN FINGER,
JOHN BARLOWE.