

(19) **DANMARK**

(10) **DK/EP 3930910 T3**



(12) **Oversættelse af
europæisk patentskrift**

Patent- og
Varemærkestyrelsen

-
- (51) Int.Cl.: **B 04 B 9/12 (2006.01)** **B 04 B 1/08 (2006.01)** **B 04 B 7/02 (2006.01)**
B 04 B 9/04 (2006.01) **B 04 B 11/02 (2006.01)**
- (45) Oversættelsen bekendtgjort den: **2025-03-03**
- (80) Dato for Den Europæiske Patentmyndigheds bekendtgørelse om meddelelse af patentet: **2025-01-15**
- (86) Europæisk ansøgning nr.: **19718724.8**
- (86) Europæisk indleveringsdag: **2019-04-24**
- (87) Den europæiske ansøgnings publiceringsdag: **2022-01-05**
- (86) International ansøgning nr.: **EP2019060456**
- (87) Internationalt publikationsnr.: **WO2020173578**
- (30) Prioritet: **2019-02-26 WO PCT/EP2019/054662**
- (84) Designerede stater: **AL AT BE BG CH CY CZ DE DK EE ES FI FR GB GR HR HU IE IS IT LI LT LU LV MC MK MT NL NO PL PT RO RS SE SI SK SM TR**
- (73) Patenthaver: **GEA Mechanical Equipment GmbH, Werner-Habig-Strasse 1, 59302 Oelde, Tyskland**
- (72) Opfinder: **GÖHMANN, Rüdiger, Von-Manger-Str. 49, 59302 Oelde, Tyskland**
- (74) Fuldmægtig i Danmark: **Patrade A/S, Ceresbyen 75, 6., 8000 Århus C, Danmark**
- (54) Benævnelse: **SEPARATOR**
- (56) Fremdragne publikationer:
WO-A1-2014/000829
WO-A1-2015/110501
WO-A2-2013/116800

Description

The invention relates to a separator according to the preamble of claim 1.

A separator for separating a flowable product into different phases is known from WO 2014/000829 A1, which has a rotatable drum with a drum lower part and a drum upper part and a means for clarification arranged in the drum, wherein one, several or all of the following elements consist of plastic or a plastic composite material: the drum lower part, the drum upper part, the means for clarification. In this way it is possible to design a part of the drum or preferably even the entire drum - preferably together with the inlet and outlet systems or areas - for single use, which is of particular interest and advantage with regard to the processing of pharmaceutical products such as fermentation broths or the like, since after operation for the processing of a corresponding product batch in preferably continuous operation during the processing of the product batch, no cleaning of the product-contacting parts of the drum has to be carried out, but the drum as a whole can be replaced. Especially from a hygienic point of view, this separator is thus very advantageous. In order to achieve a physical separation between this disposable drum and the drive, a contact-free coupling between the drive and the drum is advantageous.

From WO 2015/1100501 A1 and WO 2013/116800 A a device for separating blood into two phases of different density is both known, containing a magnetic drive device and a container which is set into rotary motion about its own axis by the drive device, wherein the container has at least one open end and in this at least one inlet, and wherein the container is magnetically suspended.

The problem is the unsatisfactorily solved bearing of the open, cup-like rotor, which therefore tends to relatively strong precession movements and is therefore limited with regard to the rotational speed and thus also with regard to the separation performance with which the device can be operated.

The invention has the object of solving this problem.

The invention solves this object by the subject matter of claim 1, which provides a separator for separating a flowable suspension in a centrifugal field into at least two flowable phases of different density, which separator comprises the following: a housing which is stationary in operation and is designed in the manner of a container which has at least two or more openings, wherein these openings comprise an inlet opening for an incoming suspension and at least one outlet or more

outlets for one or more flowable phases, optionally of different density, which are preferably each associated with annular spaces of the housing, and a rotatable drum which is arranged inside the housing, comprises a vertical axis of rotation and has a number of openings corresponding to the housing, which openings correspond to the openings of the housing, a multi-part support and drive device, comprising at least one control device and an electric motor, consisting of a stator, a stator magnet assembly and a rotor magnet assembly, by means of which the drum is held in suspension inside the housing, is radially and axially supported and is set in rotation, wherein the stator magnet assembly is arranged outside the housing and the rotor magnet assembly is formed inside the housing on the drum, so that an air gap LS is formed between the housing and the drum during operation, wherein axial centering and support of the drum is realized exclusively by controlling the position of the rotor magnet assembly by the control device by actuating the electric motor, characterized in that one or more sealing rings is/are arranged between the drum and the housing, which sealing rings additionally radially support the drum in the region in which they are arranged during operation, and a distributor and a separating means, in particular a disk pack, are arranged in the drum.

The axial and the essential radial centering of the drum is achieved with the aid of the control device, which regulates the rotary motion during operation in such a way that a largely defined axial or vertical arrangement of the rotor magnet assembly and thus of the rotor and the associated drum, which rotates within the stator magnet assembly, is ensured during operation. It is provided that the sealing ring or rings guide the drum radially in the area in which they are arranged in a complementary bearing manner during operation.

As a result, the drum with the support and drive device can not only be supported with respect to a radial direction, but can also be held in suspension and centered in an axial direction. Due to the intended disposable concept of the drum as well as the housing, the axial bearing properties of the rotor magnet are sufficient to ensure sufficient axial bearing of the drum for the present application until the processing of the intended amount of suspension is completed. To achieve a higher speed and thus a higher separation performance of the separator, it is also advantageous that the one or more mechanical seals guide the drum radially at its upper end during operation. In this way, further radial guidance of the drum is achieved simply by design.

The term "housing" should not be interpreted too narrowly. It includes completely inherently rigid containers, but also containers which are not inherently rigid, either completely or in sections.

5

It is advantageous if the sealing ring or rings are distributed adjacent to the annular spaces between the drum and the housing in order to seal them without leakage. It is also advantageous if the outlets and/or the annular spaces between the drum and the housing are sealed with one or more seals, in particular sealed against each other. In this way, the flows of suspension, light phase and possibly heavier phase into or out of the separator are reliably separated from each other.

It can be provided that the sealing ring(s) may be designed as a mechanical seal. This makes sealing with commercially available machine elements inexpensive and simple in terms of design.

15

It may be provided that the inlet is formed as an inlet pipe extending vertically from the top towards the center of the housing and that the two outlets are radially aligned.

20

It is further preferred that a first fluid outlet is formed on the drum in the upper axial section of the drum.

It may be provided that a second fluid outlet is formed on the drum in the upper axial region adjacent to the first fluid outlet.

25

Optionally, it can be provided that at least one of the liquid drains is assigned a device for adjusting the separation zone within the drum.

30

Then - advantageously for disposable operation and/or leakage-free processing - it can be provided that the housing has only the two or three openings and is otherwise designed in a hermetically closed manner.

It can also be advantageous if the seal(s) is/are designed as a mechanical seal or Elring seal. This makes sealing with commercially available machine elements inexpensive and simple in terms of design.

35

To achieve particularly high speeds and for particularly stable operation, it may be advantageous to have the first fluid outlet on the drum in the upper axial region - preferably at the upper axial end - and the second fluid outlet likewise in the upper axial region of the drum.

It can be further advantageously provided that the housing has only the two or three openings and is otherwise designed in a hermetically closed manner. This makes it easier to create a separator that has the disposable components "drum" and "housing", whereas at least parts of the support and drive device are reusable.

According to a further development, which, however, based on the preamble of claim 1, is also to be understood as an independent invention, it is provided that the housing is designed as a container which is not inherently rigid in its entirety or in sections but is deformable, preferably flexible. In these non-inherently rigid sections, the housing may still be stable enough to stand on its own as a whole, but it is not as inherently rigid as a rigid plastic container, for example a dimensionally stable plastic tank, but can easily be deformed by hand or by touch without major force. In particular, it is not so inherently rigid that it is possible to ensure a sufficient air gap without stabilizing the shape by an auxiliary means.

In this way, the housing can be made particularly simply from relatively little plastic material and, moreover, from a relatively inexpensive plastic material, and can be disposed of in a particularly uncomplicated manner. Thus, in other words, it is provided that the container as a whole or at least in sections is designed like a flexible bag.

It may be provided that the container has one or more inherently rigid sections in some areas and one or more flexible sections in some areas. In particular, it can be provided that the container has one or more inherently rigid sections in some areas and one or more flexible sections in some areas, which may connect the inherently rigid sections.

It can further be advantageously provided that the container has one of the inherently rigid sections at each of its two axial ends. One of these sections can be provided in the area of the inlets and outlets and one in the area of the rotor magnet

assembly, where an inherently rigid design is particularly advantageous for ensuring a particularly defined distance of the housing from the drum.

5 According to a further development, it can be advantageously provided that in operation the non-inherently rigid section(s) or the overall non-inherently rigid container are set by means of an auxiliary means into a state in which it is ensured that the overall non-inherently rigid container or the non-inherently rigid section(s) do not directly touch the drum in operation.

10 For this purpose, it can be provided, for example, that the auxiliary means is designed as a framework with which or on which the container is held in a stretched-out state.

15 It can also be provided that the frame is designed as a frame arranged outside the housing, on which the container is held inside in a stretched-out state. In this way, the container can be stretched out particularly easily on the inside of the frame and the frame can be used for multiple applications.

20 It may be provided that the housing is made of a plastic or a plastic composite material. It can also be provided that the drum is predominantly, preferably apart from one or more components of the drive (e.g. the rotor magnet assembly), made of a plastic or a plastic composite material. This is particularly advantageous for a use of a separator according to one or more of the claims relating thereto for a one-time operation for processing a limited amount of suspension and optionally for disposal after this processing.

25 Advantageous designs of the invention are to be taken from the subclaims.

In the following, the invention is described in more detail by means of exemplary embodiments with reference to the drawing, wherein further advantageous variants and designs are also discussed. It should be emphasized that the exemplary embodiment discussed below is not intended to describe the invention conclusively, but that variants and equivalents not shown are also feasible and are covered by the claims, wherein:

35 Fig. 1: shows a schematic representation of a separator according to the invention; and

Fig. 2: shows the separator with a receiving container surrounding it in a) a not yet stretched-out state and in b) a stretched-out state.

The separator 1 of Fig. 1 has a housing 10 which is stationary during operation.
5 This housing preferably consists entirely or at least in sections of a plastic or plastic composite material.

According to Fig. 1, the housing is formed as a substantially inherently rigid stable container which, without further aid, is stable enough to maintain a defined distance in operation from a rotor rotating within it.
10

According to Fig. 2, on the other hand, the housing 10 is designed as a container which is inherently rigid and dimensionally stable only in sections and otherwise as a non-inherently rigid and flexibly deformable container. This container therefore behaves overall or at least in sections like a deformable bag. This is described in more detail below with reference to Fig. 2. The term "housing" thus includes, on the one hand, containers which are so inherently stable or inherently rigid that they remain spaced apart from the drum during operation and, on the other hand, containers which are not inherently rigid either in their entirety or in sections and which can then optionally be held in an inherently rigid state by an auxiliary means such as a support structure 150 – e.g. designed as a frame. According to Figs. 2a and b, the frame is an external frame outside the container, which can be held in a stretched-out manner in said frame by tensioning means 151 such as tensioning belts, rubber rings or the like (Fig. 2a) and (in Fig. 2b) is also kept in a stretched-out state during operation.
15
20
25

Here, the housing 10 has a lower section 101 and an upper section 102. The lower section 101 may be configured as a cylindrical section. This may in turn be divided into one or more cylindrical regions 101a, 101b of different diameters.
30

For example, the lower section 101 may include a first lower - here cup-like - region 101a having a first diameter and having a closed bottom at the lower end. This first section 101a is substantially for receiving drive components of a drive of a rotor on a drum. The first section 101a may be followed vertically upwardly by a second section 101b, preferably of larger diameter.
35

Axially upwards, the lower section 101 is thus followed by the upper section 102. This can be provided with a conically tapering design at least in a lower region 102a. Towards the top, this conical section 102a can be adjoined by a housing head 102b. This can in turn be of cylindrical design and stepped in itself.

5

This shape is preferred, but not mandatory. In particular, the lower section 102 can also be designed in a conical or sectionally conical and cylindrical manner.

According to Figs. 2a and 2b, in particular the lower cup-like region 101a and the housing head 102b may be inherently rigid and may be designed, for example, as injection-molded plastic elements. The region between these elements 101a and 102b can consist of a flexible plastic tube section 101b, 102a (Fig. 2a). This can be stretched out (Fig. 2b). Thus, it may be attached to an external framework 150, such as with tensioning means 151 such as pulling means and hooks, or in some other way, so that as a result of this tensioning (Fig. 2b) it forms a housing 10 which is sufficiently stable in operation so that in operation it does not contact a rotating rotor, which will be explained below and which it surrounds.

The housing 10 is designed in the manner of a container which is advantageously hermetically closed except for openings, in this case at least two or three openings (to be discussed). These openings are an inlet opening 103 and one or two fluid outlets 104, 105. If only a single outlet opening is provided, a solid phase in batch operation can also be collected internally in a drum and disposed of with the entire separator after a complete processing of an intended amount of suspension to be processed (not shown here).

The inlet opening 103 is penetrated by an inlet tube 106 that extends vertically from above toward the center of the housing 10. The two fluid outlets 104, 105 here may extend substantially radially.

30

The first fluid outlet 104 and, here, the further second fluid outlet 105 are formed in the housing head 102b of the upper section 102 of the housing 10. Preferably, they are formed directly at the upper end of the housing 10.

Upstream of the one or two or more outlets 104, 105 are one or more annular spaces 107, 108 of the housing. The one or more outlets 104, 105 allow one or more flowable phases to drain from the one or more annular spaces 107, 108

during operation of the then rotating drum 20. The significance and beneficial effect of the one annular space or the two or more annular spaces 107, 108 will be further explained below.

5 The fluid outlet(s) 104, 105 of the housing are designed here as nozzles leading radially out of the housing 10, to which lines, in particular hoses or the like (not shown here), can be connected. Preferably, one inlet and several outlet lines, in particular outlet pipes or hoses, are connected to the inlets and outlets. These can in turn have a certain inherent rigidity so that they further stabilize the arrangement, in particular the housing, and hold it spatially to a limited extent.

10 Inside the housing 10, a rotatable rotor of a drive device is arranged on and with a rotatable drum 20 with an imaginary "ideal" axis of rotation D, which is a vertical axis of rotation. The real axis of rotation deviates from the vertical due to precession movements.

15 The drum 20 and its components are also preferably made entirely or in any case for the most part (ideally except for magnets to be explained) of a plastic material or of a plastic composite material. The drum 20 may also have a lower cylindrical and/or conical section 201 and an upper conical section 202, as well as a type of drum head consisting of cylindrical projections extending vertically upward in the orientation of Figs.1 and 2.

20 The inlet pipe 106 of the housing 10, like the housing 10, may be stationary in operation. It extends vertically from above through the inlet opening of the housing 10 into the drum 20 into a distributor pipe 203 of the distributor 204 of the drum 20, which is concentric with the inlet pipe. The distributor forms part of the rotating system (rotor or drum).

25 Upstream of the one or more fluid outlets 104, 105 are in turn the one or more annular spaces 107, 108 of the housing. The outlets allow fluid to drain from the annular spaces 107, 108 during operation of the then rotating drum 20.

30 In order to seal the fluid outlet(s) 104, 105 and/or the annular spaces 107, 108, in particular to seal them against each other, one or more -here three- seal(s) 109 are provided between the drum 10 and the housing 20. These seals are designed here as sealing rings.

In the example of Fig. 1, three radially acting sealing rings 109a, 109b as well as 109c in an air gap between the drum 20 and the housing 10 seal an axially upper outer region radially outside on the drum 20 against an axially upper and radially inner region of the housing 10.

The sealing ring(s) 109 is/are preferably designed here as mechanical seal(s). Alternatively, other sealing rings such as Elring seals can also be used.

Due to the intended disposable concept of the drum 20 as well as the housing 10, the plain bearing characteristics of the mechanical seals 109 are sufficient to ensure adequate radial bearing support of the drum 20 in the intended one-time operation.

The plain bearing characteristics of the mechanical seals 109 guide the drum 20 radially at its upper end -also called the drum head- during operation.

Compensating and oscillating movements of the drum 20 due to the precession of the drum 20 can be compensated for by a rotor magnet 332, to be explained later, in interaction with a suitable control system in a manner sufficient for one-time operation.

First, the further construction of the rotor should be explained in more detail.

The distributor pipe 203 of the distributor 204 opens downward into radial distributor channels 205, which lead into a separation chamber or centrifugal chamber 206. A clarifying agent such as a disk pack 207 may be disposed in this separation chamber 206. The distributor 204 may have a distributor base 205a, which in turn has a lower cylindrical extension 205b that projects downward axially from the drum 20, in particular from its cylindrical section 201.

30

In the separation chamber 206, a suspension S to be processed, which is fed into the drum 20 through the feed pipe 106, is separated by centrifugal force into at least two flowable phases LP and HP of different density during the driven rotational operation of the drum 20. The lower-density phase LP flows radially inwardly in the separation chamber 206, where it is discharged upwardly through a first discharge channel 208 into the radial discharge 209 and is ejected radially through the radial discharge 209 from the rotating drum into the first annular

35

space 107. Here, the phase LP leaves the drum 20 at a radius r_i . From there, it flows - circling in the annular space due to its momentum - out of the housing 10 through the upper fluid outlet 104.

5 The higher-density phase HP flows radially outwardly in the separation chamber 206 and is expelled upwardly through a second discharge channel 210 into the radial discharge 211 and is expelled radially through the latter from the rotating drum into the second annular space 108. Here the phase HP leaves the drum 20 at a radius r_a . From there it flows - circling in the annular space 108 due to its
10 momentum - out of the housing 10 through the lower fluid outlet 105. It may also be provided that this phase or another or different phase - e.g. a waste phase to be disposed of - collects externally in the drum 20 during operation if it consists of solids, so that the solid phase is not drained. The drum 20 then has only a single discharge.

15

The ratio of r_a to r_i can be used to adjust the radius of the separation zone between the two phases within the disk pack and thus realize a regulation of the flow rates of the individual phases. The radius of the separation zone can also be changed by throttling the fluid outlets 104 and/or 105.

20

In the vertical region below the annular spaces, the housing 10 and the drum 20 are spaced apart by an air gap LS. This is advantageous because a high rotational speed of the drum 20 can be achieved relatively easily in this way. In this area, the air gap LS is not filled with one of the phases HP, LP to be discharged.

25

The drum 20 is suspended and rotated within the housing 10 by a single electromagnetic support and drive device 30. The single electromagnetic support and drive device 30 has a single bearing and drive unit.

30 The electromagnetic support and drive device 30 comprises an electric motor 330, which includes a type of base having a stator 331 with a stator magnet assembly 333 external to the housing 10. The housing 10 may be placed on the base during operation. A control unit may also be provided outside the housing 10. Thus, these drive components are advantageously reusable and not intended for disposable
35 batch operation.

In contrast, a rotor with a rotor magnet assembly 332 may be formed inside the housing 10 on the drum 20 and may be provided for disposable operation only. This rotor magnet assembly 332 may be disposed of after operation or, alternatively, may be reused after suitable disposal of the remainder of the housing 10 and drum 20.

The rotor magnet assembly 332 is then arranged on the drum 20 within the housing 10. This may be formed on the drum 20 in a lower region that extends into the lower cup-like section of the housing, but which the drum 20 does not contact during operation.

As a result of suitable control of the drive by a control unit, the entire rotor is set in rotation, wherein, due to the magnetic effect between the stator and rotor, it is not only rotated but enters a state of suspension which is maintained during operation.

The axial and radial centering of the drum 20 is effected by the control device, which in operation regulates the rotary movement and ensures in a regulating manner that in operation a largely defined axial or vertical arrangement of the rotor magnet assembly and thus of the rotor, which rotates within the stator magnet assembly, is ensured.

The axial centering of the rotor magnet 332 and thus of the drum 20 is thus realized entirely or substantially solely by the control and regulation of the stator magnet 333 by the control unit. This regulation can be supported by one or more sensors on the non-rotating and/or on the rotating system.

In this way, the drum 20 can not only be supported with respect to a radial direction, but can also be held in suspension and centered in an axial direction. Due to the intended disposable concept of the drum 20 as well as of the housing 10, sufficient radial and also axial bearing of the drum 20 is ensured for the present application.

The drive device 30 can be operated electromagnetically. However, a drive via rotating permanent magnets can also be realized.

Suitable support and drive devices 30 are used and offered by the company Levitronix, e.g. for driving centrifugal pumps (EP2273124B1). The control is easily

programmable by the person skilled in the art, optionally accompanied by tests, in such a way that the radial and bearing of a separator is ensured.

5 In operation, the drum 20 thus rotates. In this case, it is held axially in suspension and radially centered. Preferably, the drum 20 is rotated at a speed of between 1,000 and 20,000 revolutions per minute. The forces generated by the rotation lead to the separation of a suspension to be processed into different phases and, optionally, to their discharge, as already described in detail above.

10 With the described embodiment, it is again possible to create a separator together with housing, which can be designed for single use except for the drive system and parts of the bearing, which is again of interest and advantage in particular with regard to the processing of pharmaceutical products such as fermentation
15 broths or the like, since after operation for processing a corresponding product batch in preferably continuous operation during the processing of the product batch, no cleaning of the drum 20 has to be carried out, but the drum 20 together with housing 10 can be replaced as a whole. Optionally, individual elements such as magnets can be suitably recycled.

For certain applications, it may be necessary for all components that come into
20 contact with the product to be completely germ-free or sterilized. This requires sterilization of these components with e.g. beta rays. The materials may have to be suitable for such irradiation.

According to one variant, the running surfaces of the seals can consist of steel sleeves. In order to be able to sterilize these as well, they must be made of auto-
25 claved steel.

List of reference numerals

	Separator		1
5	Housing		10
	Lower cylindrical section		101
	Upper conical section		102
	Inlet opening	103	
	Fluid outlets		104, 105
10	Inlet pipe		106
	Annular spaces		107, 108
	Seal		109, 109a, 109b, 109c
	Housing head		110
15	Drum		20
	Lower cylindrical section		201
	Upper conical section		202
	Distributor pipe		203
	Distributor		204
20	Distributor channels	205	
	Separation chamber	206	
	Disk pack		207
	Distributor base		205a
	Cylindrical extension	205b	
25	Discharge channel		208
	Discharge		209
	Discharge channel		210
	Discharge		211
30	Support and drive device		30
	Electric motor		330
	Stator		331
	Rotor magnet	332	
	Stator magnet		333
35			
	Axis of rotation		D
	Suspension		S

Flowable phases		LP and HP
Air gap		LS
Radius	r_i	
Radius	r_a	

Patentkrav

1. Separator (1) til adskillelse af en flydende suspension S i et centrifugalfelt i mindst to faser LP, HP af forskellig tæthed, som omfatter følgende:

5

a) et hus (10), der er stationært under drift og er udformet som en beholder, der har mindst to eller flere åbninger (103, 104, 105), hvor disse åbninger (103, 104, 105) omfatter en indløbsåbning (103) til en indløbende suspension S og mindst et eller flere udløb (104, 105) til flydende faser LP, HP af forskellig tæthed, til hvilke der foretrukket er tilknyttet respektive ringformede rum (107, 108) i huset (10),

10

b) en drejelig tromle (20) anbragt inde i huset (10) med en vertikal drejeakse D, som har et antal åbninger (203, 209, 211) til huset (10), der korresponderer med åbningerne (103, 104, 105) i huset (10) fra a),

15

c) en enkelt flerdelt leje- og drivanordning (30), med mindst en styringsanordning samt en elektrisk motor (330), bestående af en stator (331), en statormagnetindretning (333) samt en rotor med en rotormagnetindretning (332), med hvilken tromlen (20) holdes svævende, lejreres radiale og aksiale og roteres inde i huset (10),

20

d) hvor statormagnetindretningen (333) er anbragt uden for huset (10), og rotormagnetindretningen (332) er udformet inde i huset (10) på tromlen (20),

e) sådan at der mellem huset (10) og tromlen (20) under rotationen af tromlen (20) under drift er udformet en luftspalte LS,

25

f) hvor den aksiale lejrering og centrering af tromlen (20) er realiseret af den flerdelte leje- og drivanordning (30), af regulering af den aksiale position af rotormagnetindretningen (332) af styringsanordningen ved styring af den elektriske motor,

30

kendetegnet ved, at

g) der mellem tromlen (20) og huset (10) er anbragt en eller flere tætningsringe, som under drift på supplerende vis lejrer tromlen (20) radiale i det område, hvor de er anbragt, og

35

h) der i tromlen (20) er anbragt en fordeler (204) og en adskillelsesmekanisme, særligt en pladepakke (207).

2. Separator ifølge krav 1, kendetegnet ved, at tætningsringen eller tætningsringene er fordelt ved siden af de ringformede rum (107, 108) mellem tromlen (10) og huset (20) i området med det ene udløb eller de flere udløb.
- 5 3. Separator ifølge krav 1 eller 2, kendetegnet ved, at tætningsringen eller tætningsringene (109) er udformet som glideringstætning eller Elring-tætning.
- 10 4. Separator (1) ifølge et af de foregående krav, kendetegnet ved, at indløbet er udformet som indløbsrør (106), der strækker sig vertikalt oppefra i retning mod husets (10) centrum, og at væskeudløbet eller væskeudløbene (104, 105) er justeret radialt.
- 15 5. Separator (1) ifølge et af de foregående krav, kendetegnet ved, at der på tromlen (20) er udformet en første udledning (209) i det øvre aksiale afsnit (102) af tromlen (20).
- 20 6. Separator (1) ifølge krav 5, kendetegnet ved, at der på tromlen (20) er udformet en anden udledning (211) i det øvre aksiale område ved siden af den første udledning (209).
- 25 7. Separator (1) ifølge et af de foregående krav, kendetegnet ved, at huset (10) udelukkende har de to eller tre åbninger og ellers er hermetisk lukket.
- 30 8. Separator (1) ifølge et af de foregående krav, kendetegnet ved, at huset (10) er udformet som formforanderlig beholder, der helt eller afsnitsvist ikke har en stivhed i sig selv.
- 35 9. Separator (1) ifølge krav 8, kendetegnet ved, at beholderen eller i det mindste afsnit heraf er udformet som en pose.
10. Separator (1) ifølge krav 8 eller 9, kendetegnet ved, at beholderen afsnitsvist har et eller flere afsnit, der har en stivhed i sig selv, og afsnitsvist har et eller flere afsnit, der ikke har en stivhed i sig selv.

11. Separator (1) ifølge et af kravene 9 til 11, kendetegnet ved, at beholderen i begge sine aksiale ender har hvert et af de afsnit, der har en stivhed i sig selv.

5 12. Separator (1) ifølge et af kravene 8 til 11, kendetegnet ved, at det eller de afsnit, der ikke har en stivhed i sig selv, eller hele beholderen, der ikke har en stivhed i sig selv, ved hjælp af et hjælpemiddel sættes i en tilstand, i hvilken det sikres, at hele beholderen (10), der ikke har en stivhed i sig selv, eller det eller de afsnit, der ikke har en stivhed i sig selv, ikke direkte berører tromlen (20) under drift.

10

13. Separator (1) ifølge krav 12, kendetegnet ved, at hjælpemidlet er udformet som et stillads, med hvilket eller på hvilket beholderen holdes udspændt.

15

14. Separator (1) ifølge krav 13, kendetegnet ved, at stilladset er udformet som et stillads anbragt uden for huset (10), på hvilket beholderen holdes indvendigt i en udspændt tilstand.

20

15. Separator (1) ifølge et af de foregående krav, kendetegnet ved, at huset (10) består af plast eller et plastkompositmateriale, særligt på en sådan måde, at tromlen (20) overvejende, foretrukket med undtagelse af en eller flere komponenter af drevet består af plast eller et plastkompositmateriale.

Fig. 1

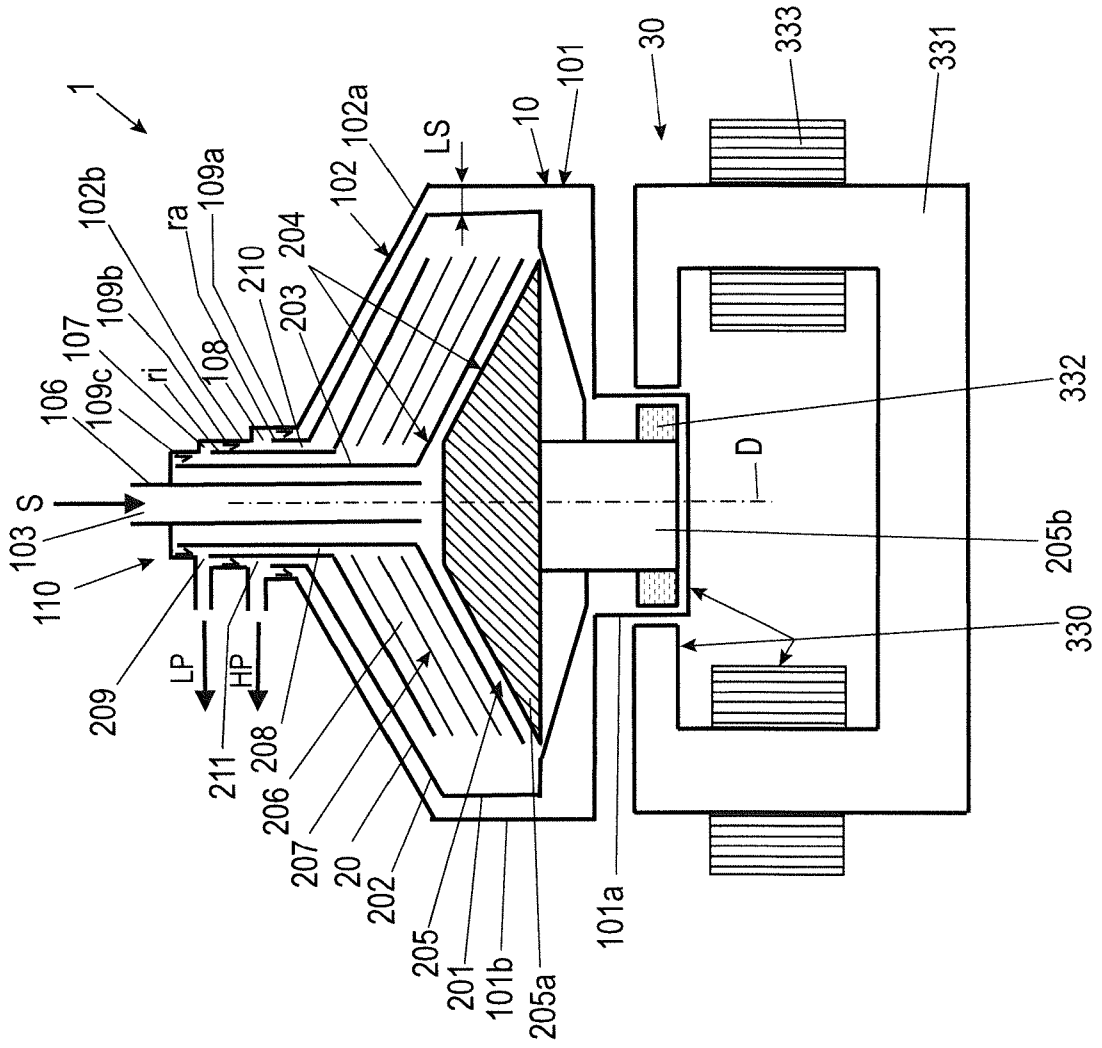

Fig. 2a

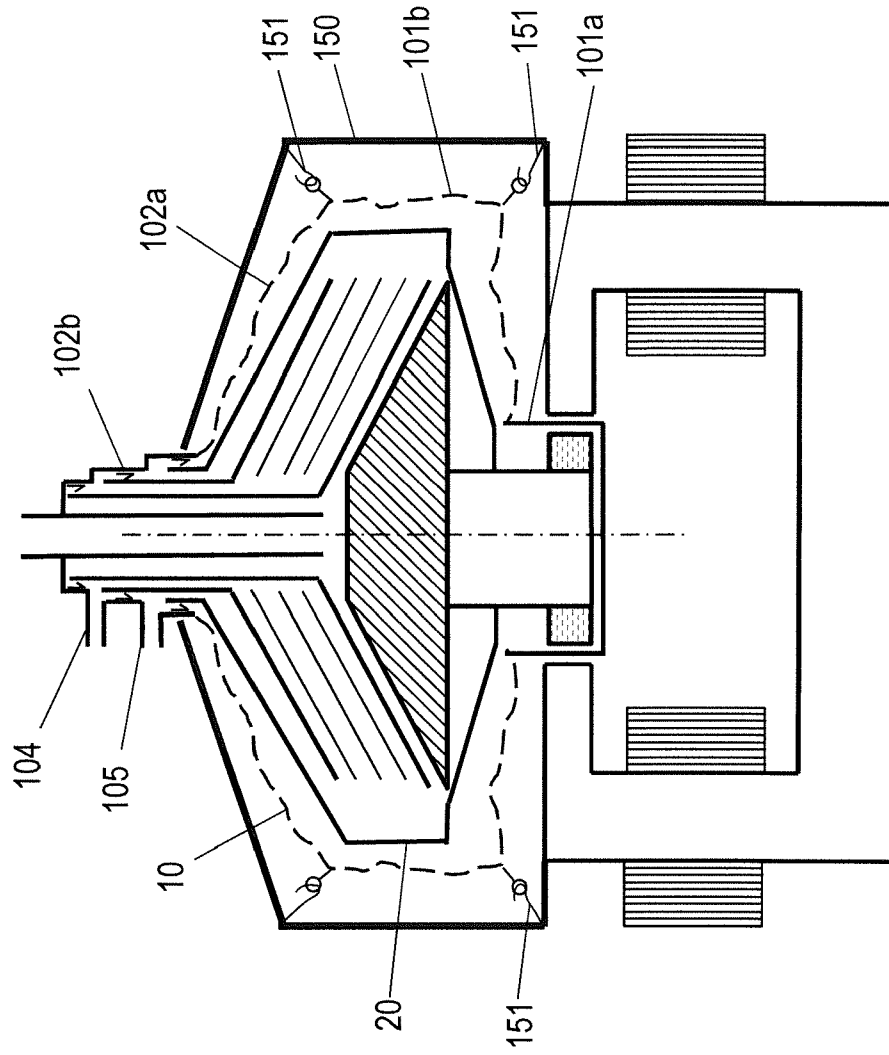

Fig. 2b

