

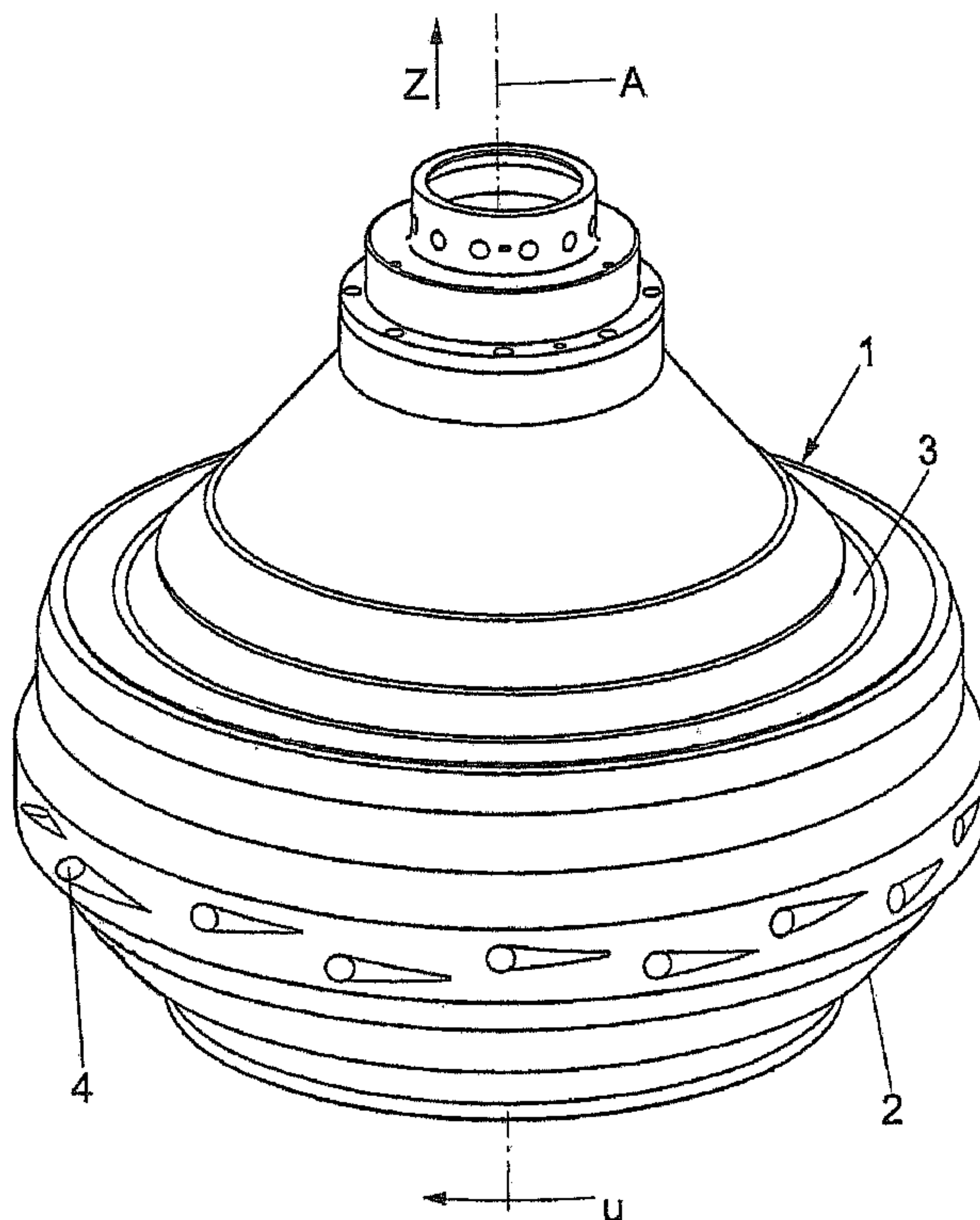

(86) Date de dépôt PCT/PCT Filing Date: 2007/11/08  
 (87) Date publication PCT/PCT Publication Date: 2008/05/22  
 (45) Date de délivrance/Issue Date: 2015/04/07  
 (85) Entrée phase nationale/National Entry: 2009/05/28  
 (86) N° demande PCT/PCT Application No.: EP 2007/062029  
 (87) N° publication PCT/PCT Publication No.: 2008/058883  
 (30) Priorité/Priority: 2006/11/14 (DE10 2006 053 491.3)

(51) Cl.Int./Int.Cl. *B04B 1/10* (2006.01)  
 (72) Inventeurs/Inventors:  
 MACKEL, WILFRIED, DE;  
 PENKL, ANDREAS, DE;  
 BATHELT, THOMAS, DE;  
 QUITER, KATHRIN, DE;  
 BAALMANN, KLAUS, DE  
 (73) Propriétaire/Owner:  
 GEA MECHANICAL EQUIPMENT GMBH, DE  
 (74) Agent: FETHERSTONHAUGH & CO.

(54) Titre : CENTRIFUGEUSE, EN PARTICULIER SEPARATEUR, DOTEE DE TUYERES DE SORTIE DE SOLIDE  
 (54) Title: CENTRIFUGE INCLUDING A DRUM AND SOLID DISCHARGE ORIFICES HAVING BORES ARRANGED AT  
 SELECTED VERTICAL HEIGHTS ALONG AN EXTERIOR OF THE DRUM



(57) Abrégé/Abstract:

A centrifuge, especially separator, with a centrifuging drum (2) which is rotatable about a preferably vertical axis of rotation (D) and has a drum jacket provided with at least one or a plurality of solid discharge orifices which have bores (7) with discharge orifices (10) is characterized in that the bores (7) are arranged completely or partly in vertical direction at different heights (Z axis).

## ABSTRACT

A centrifuge, especially separator, with a  
5 centrifuging drum which is rotatable about a preferably  
vertical axis of rotation (D) and has a drum jacket  
provided with at least one or a plurality of solid  
discharge orifices which have bores with discharge  
orifices is characterized in that the bores are arranged  
10 completely or partly in vertical direction at different  
heights (Z axis).

**CENTRIFUGE INCLUDING A DRUM AND SOLID DISCHARGE ORIFICES  
HAVING BORES ARRANGED AT SELECTED VERTICAL HEIGHTS ALONG  
AN EXTERIOR OF THE DRUM**

5 FIELD OF THE INVENTION

The present invention relates to a centrifuge having a centrifugal drum rotatable about an axis of rotation. The centrifuge may be a separator having a centrifugal drum rotatable about a vertical axis of rotation. The rotatable drum may have a single cone or biconical construction in an interior. The drum is provided, in an area of its largest inside diameter, with at least one or more solids discharge orifices having bores with discharge openings.

BACKGROUND

A separator of this type is known from U.S. Patent Document US 3,108,952. Solids discharge orifices are arranged in a mutually angularly offset manner in the exterior jacket of the centrifugal drum in the area of the largest inside diameter of the centrifugal drum. Orifice bodies are in each case inserted into bores of the drum jacket, which orifice bodies do not extend radially to the outside but are oriented in an inclined fashion with respect to the respective radial direction in order to utilize the acceleration effect of the product phase exiting from the orifices, which reduces the energy required for rotating the centrifugal drum.

Since the discharge orifices are arranged inclined with respect to the radial direction, at least a certain

portion of the product stream exiting from the discharge orifices may strike the exterior drum jacket or collide with this jacket, which may result in considerable wear of the exterior drum jacket.

5

In particular, as a result of erosion, grooves may form in the exterior drum jacket, which become deeper and longer over time and therefore limit the useful life of the drum.

10

U.S. Patent Document US 2,695,748 shows a similar state of the art. The discharge orifices illustrated in that document in each case consist of a first sleeve with a bore extending centrally through the sleeve from the interior radially to the outside. The first sleeves are inserted into the bores of the drum jacket. A second sleeve is in each case screwed into them in their end region at an angle with respect to the radial direction, which second sleeve also has a centric bore, so that the product phase exiting from the centrifugal drum is first guided through the first sleeve radially to the outside and then through the second sleeve, from which it exits in an inclined manner with respect to the radial direction against the rotating direction of the separator.

25

From U.S. Patent Document US 2,695 748, it is also known to insert the first sleeve also at an angle with respect to the radial direction into a bore of the drum jacket. At its outer end, the sleeve closes off approximately flush with the exterior side of the centrifugal drum, which has the result that behind the discharge of the sleeve with the orifice, the product

30

stream in a recess of the centrifugal drum can strike against the drum jacket and may erode it. A projection engaging in a groove of the centrifugal drum is used for fixing the first sleeve to the centrifugal drum.

5

A similar construction is shown in U.S. Patent Document US 2,060,239.

For solving this problem, it was suggested in German  
10 Patent Document DE 202 19 551 of the above-mentioned type to arrange at least one protection element against wear made of a hard metal in each case on the drum jacket in the area of the solids discharge orifices, and/or to construct a coating of a ramp in the exterior drum  
15 jacket. These measures cause additional expenditures.

From Austrian Patent Document AT 9622 B, a centrifugal drum is known which, in the vertical direction, is divided several times by disks into  
20 individual centrifugal spaces of a respectively biconical contour, on whose largest inside diameter discharge openings are constructed in each case.

Concerning the state of the art, reference is also  
25 made to French Patent Document FR 1,598,924 A which shows a separator having a drum which in sections has several jackets.

In addition, German Patent Document DE 36 19 298  
30 shows a disk separator having a biconical drum interior, on whose largest inside diameter solids discharge orifices are constructed. By way of tubes which, at an axially offset position of the drum situated "higher" in

the vertical arrangement and radially farther inside, lead out of the drum, in addition, a product phase, which contains only a few solids, can be guided out of the drum from a radius situated farther in the interior. As a  
5 result, a product phase of a different nature is discharged through tubes than through the solids discharge orifices.

#### SUMMARY OF THE INVENTION

10

The present invention relates to, among other things, a centrifuge configured to prolong the service life of the drum by means of simple devices.

15

The present invention thus relates to a centrifuge including a centrifugal drum rotatable about a vertical axis of rotation. The centrifugal drum includes one or more solids discharge orifices located at an area of the largest inside diameter of the drum. The solids discharge  
20 orifices includes bores having discharge openings. The bores are arranged at least partially on an exterior of the centrifugal drum in a vertical direction Z at selected vertical heights along the exterior of the centrifugal drum.

25

Accordingly, the bores are completely or at least partly arranged in the axial or preferably vertical direction at a different height (Z-axis) in the solids discharge orifices in the area of the largest inside  
30 diameter in the centrifugal drum which is conical or biconical on the inside.

According to the invention, it may be advantageous that the recesses or indentations in the drum jacket which, related to the rotating direction of the drum, are situated in each case behind the discharge orifices. The  
5 recesses or indentations may, as a result of the increasing wear when in use, become increasingly longer and can reach a much greater length in the circumferential direction before they reach the respectively next discharge orifice in the  
10 circumferential direction. This is compared to the situation when all of the discharge openings are situated at only one vertical height along or relative to the Z-axis, which is parallel to the axis of rotation.

15 According to the invention, an effective protection against wear of the separator drum is implemented in a simple manner such that the service life of the drum or of the part of the drum which has the discharge openings can be increased. This part is usually the bottom part  
20 of the drum.

It may be advantageous that, as desired, the measure for the protection against wear can also be combined with additional measures for the protection against wear, such  
25 as coatings or elements in the area of the discharge openings.

The invention is suitable for separators whose centrifugal drums have a vertical axis of rotation and  
30 which, on the inside and/or outside, have a single-cone or biconical construction. The solids discharge orifices having orifice bodies which are arranged in the area of

the largest diameter of the centrifugal drum or may be inserted into the drum from the outside.

5 The invention may be used in the case of separators whose discharge openings are arranged to be offset toward the inside by a distance relative to the largest outer circumference or outside diameter of the centrifugal drum. The discharge openings may each have a groove-type indentation or recess as an extension of the discharge  
10 openings in the drum jacket which, as a rule, have a wedge-shaped further development, so that the solids can exit at a flat angle which, if possible, approximates a tangent.

15 The discharge openings may be situated in the circumferential direction alternately in two mutually parallel planes which are oriented perpendicular to the vertical, or the Z-axis. In the circumferential direction, the discharge openings are arranged  
20 alternately in the first plane and in the second plane, which results in a particularly effective protection against wear.

In some embodiments, the position and orientation of  
25 the actual bores remain unchanged, and only the respective orifice bodies are oriented slightly differently. That is so that their discharge openings are in each case preferably situated completely at different planes perpendicular to the vertical line.

30

Such an embodiment has an advantage that neither the bores nor the orifice bodies per se have to be changed in

comparison to known constructions. It is only necessary to orient the orifice bodies in a different manner.

5 An analogous effect could be achieved, according to the present invention, by the use of different orifice bodies which are provided with differently oriented bores but are mounted in an identical fashion.

10 According to -another embodiment, the inlet openings and also the interior mouths of the openings are situated at a common vertical height. As a result, at least the contour of the drum interior does not have to be changed.

15 In contrast, the bores themselves have a different orientation, for example, in the circumferential direction, alternately diagonally upward and diagonally downward relative to the Z-axis. Thus, at least the discharge openings of the orifice bodies screwed into the bores are situated at a different vertical height.

20

In a simple fashion, a greater vertical offset of the area of the discharge opening can thereby also be achieved than by the sole measure of the different orientation of the orifice bodies in the openings. Naturally, these two measures can also be combined so that, if necessary, they complement one another according to the invention.

25 It is advantageous for the discharge openings to lead to the outside in an annular area of the drum in which the drum jacket has a constant diameter.

According to another embodiment, the bores are situated completely, in the area of their interior inlet opening, at a different vertical height. This has an advantage but requires a new contouring of the interior drum jacket, as shown, for example, in Figure 2.

In other embodiments of the present invention, the openings may be arranged in the circumferential direction in three or more different planes.

10

In accordance with an aspect of the present invention, there is provided a centrifuge for isolating a selected solids phase at a separation level, said centrifuge comprising: a centrifugal drum rotatable about an axis of rotation, said centrifugal drum having an external surface and an internal surface, said internal surface defining a largest inside diameter relative to said axis of rotation; and a plurality of solids discharge orifices disposed around said largest inside diameter, each of said plurality of solids discharge orifices comprising a bore having an inlet opening at said internal surface and an associated discharge opening at said external surface; wherein each of said inlet openings is disposed at the separation level to receive the selected solids phase; wherein each solids discharge orifice of said plurality of solids discharge orifices is configured to project from said associated discharge opening a stream of the selected solids phase in a stream direction; and wherein said associated discharge openings that are adjacent each other are disposed at different discharge positions along said axis of rotation; or wherein said associated discharge openings lie on a common

30

radial plane perpendicular to said axis of rotation, and wherein said bores are configured to direct the streams of the selected solids phase exiting said associated discharge openings in directions offset from said common radial plane.

5

In accordance with another aspect of the present invention, there is provided a centrifuge for isolating a solids phase, said centrifuge comprising: a centrifugal drum rotatable about an axis of rotation, said centrifugal drum  
10 having an external surface and an internal surface which has a biconical configuration, said internal surface defining a largest inside diameter relative to said axis of rotation; a separating disk stack comprising a separation disk being inserted in said centrifugal drum; and a plurality of solids  
15 discharge orifices disposed around said largest inside diameter, each of said plurality of solids discharge orifices comprising a bore having an inlet opening at said internal surface and an associated discharge opening at said external surface; wherein each of said inlet openings is disposed at  
20 said largest inside diameter of said centrifugal drum so as to define an inlet plane that is perpendicular to said axis of rotation; and wherein each solids discharge orifice of said plurality of solids discharge orifices is configured to project from said associated discharge opening an associated stream of  
25 the solids phase in an associated stream direction and further configured according to at least one of the following configurations: said solids discharge orifices are configured to direct the streams of the solids phase that are adjacent each other in different directions; and said solids discharge  
30 orifices are configured to dispose said discharge openings that

are adjacent each other on different planes that are perpendicular to said axis of rotation.

In accordance with another aspect of the present invention, there is provided a centrifuge comprising: a centrifugal drum rotatable about a vertical axis, said centrifugal drum having an external surface and a single-conical or biconical internal surface, said internal surface defining a largest inside diameter; and solids discharge orifices disposed in an area of said largest inside diameter, each of said solids discharge orifices comprising a bore having an inlet opening at said internal surface and an associated discharge opening at said external surface; wherein, in a circumferential direction, said bores are alternately oriented diagonally upward and diagonally downward relative to said inlet openings.

Other aspects and features of the present invention will become apparent to those ordinarily skilled in the art upon review of the following description of specific embodiments of the invention in conjunction with the accompanying drawings.

#### BRIEF DESCRIPTION OF THE DRAWINGS

The invention will now be described in greater detail with reference to the accompanying drawings:

Figure 1 is a perspective view of a separator drum;

Figure 2 shows different views and areas of a drum bottom part;

5

Figure 3 is a view of conceivable outlines of the wear at the drum bottom part from Figure 2;

Figure 4 is a view of an enlargement of a cutout of an area X of Figure 2a; and

10

Figure 5 is a schematic diagram illustrating the operating principle of a further variant of the invention.

15

#### DETAILED DESCRIPTION

Figure 1 is a perspective view of a separator drum 1 with a vertical axis of rotation . The vertical height at the drum 1 relative to the axis of rotation A is called "Z" (see Figure 2). The rotating direction of the drum 1 is marked by the arrow U.

20

The separator drum 1 has a drum bottom part 2 and a drum top part 3 which form an exterior drum jacket of, for example, biconical geometry. Embodiments with single-cone drums or non-conical drums can also be implemented according to the invention. In addition, the drums may have a single-cone or biconical construction with respect to their interior.

30

A separating disk stack having separating disks may be inserted into the separator drum 1 (not shown).

The separator drum 1 also has an inlet pipe (not shown) and liquid outlets (not shown). The separator drum 1 may be constructed as a two-phase machine (e.g. a solids phase and a liquid phase) or as a three-phase machine (e.g. a solids phase and two liquids phases). Furthermore, the separator drum 1 may be continuously operated and may continuously discharge the solids phase.

10 The separator drum 1, and more particularly, the drum bottom part 2, is provided with several discharge orifices. For this purpose, at least two, and possibly several openings, such as bores 4, penetrate the separator drum 1. These bores 4 are formed in the area  
15 of the largest diameter (see Fig. 2) of the drum 1 and penetrate the drum jacket from the drum interior to the outside. A sleeve-type orifice body 5 is inserted, for example, screwed, into each of the bores 4 (see, for example, Figures 2 and 4). This permits the solids to be  
20 discharged from the drum interior.

According to Figure 2, the drum bottom part 2 has a recess 6, for example, in the area in which it is penetrated by the openings 4, and located radially in front of each opening 4. Recess 6 tapers toward the  
25 outside in the direction of the openings 4. As a result, the buildup of solids or solid segments between the orifice bodies 5 is minimized.

30 The orifice bodies 5 are each provided with a bore 7 extending from the drum interior in the direction of the drum exterior. Bore 7 extends in a first bore section 8 at first essentially in the radial direction from the

inside to the outside and then changes into a bore section 9 oriented at an angle with respect to the first bore section 8 (Figures 2, 4).

5           The discharge opening 10 of the bore section 9 is oriented at an angle with respect to the radial direction R such that the angle  $\alpha$  between the radial direction and the discharge opening 10 or the second bore area 9 is equal to or smaller than  $90^\circ$ . For example, angle  $\alpha$  may  
10 be between  $45^\circ$  and  $90^\circ$ .

          Since the orifice bodies 5 on the outside close off essentially flush with the outer edge of the drum jacket or exterior of the separator drum 1, the discharge  
15 opening 10 is offset toward the interior relative to the largest outer circumference or diameter of the centrifugal drum 1 or of the drum jacket.

          Groove-type indentations or recesses 11 are formed  
20 at an angle with respect to the radial direction as an extension of the second bore section 9. These recesses 11 may already be constructed in the drum jacket, so that the product phase exiting from the discharge orifices, if possible, will spray past the drum jacket on the outside.

25  
          However, in such a construction, a portion of the solids S (see Figure 4) exiting from the discharge openings 10 will strike the drum jacket again and could, depending on the product to be processed, cause an  
30 erosion of the drum jacket, for example in the exterior area of the recess 11 as well as also farther in the circumferential direction. Because of this erosion, the

groove-type indentation 11 may possibly lengthen over time (compare Figures 2 and 3).

It is therefore provided that the bores 7 of the orifice bodies 5 (and possibly also the bores 4 in the drum jacket which receive the orifice bodies 5) are situated completely, or at least in the area of their discharge openings 10, in the vertical direction not in one plane but in at least two or more mutually different planes E1, E2 (see Figure 2d).

Thus, at least the discharge openings 10 are situated in two mutually parallel planes E1 and E2, which are oriented perpendicular with respect to the vertical or to the Z-axis. As a result, they are arranged in the circumferential direction alternately in the first plane E1 and in the second plane E2. This is visible particularly in Figure 2d.

Figure 5 illustrates that, according to another embodiment, although the discharge openings 10 are situated in one plane, the bores 4 or areas in front of the discharge openings 10 are oriented such that the solids are emitted in different directions diagonally upward and downward, so that the service life is also prolonged.

Furthermore, the inlet openings 12 of the bores 7, in contrast, may be situated in a common plane with respect to the drum axis, so that the contour of the interior jacket of the separator drum does not have to be changed by the measure of arranging the discharge

openings 10 in at least two or more different planes (see Figures 4 and 5).

This results in the advantage that the recesses 11 behind a discharge orifices or openings 10, which become increasingly long as a result of wear when in use, may reach a much greater length in the circumferential direction before, against the rotating direction, they reach the respectively next discharge orifice 10, shown as bores 4, in the circumferential direction, than if all the discharge orifices 10 were situated in only one plane (Figure 3).

Other embodiments are conceivable within the scope of the present invention.

In one such an embodiment, the position and orientation of the bores 4 are left unchanged and only the orifice bodies 5 are oriented in a slightly different manner, so that their discharge orifices 10 will be situated in different planes with respect to the vertical line or Z-axis.

According to the embodiment of Figures 1 to 3, the inlet openings 12 or the interior mouths of the openings 4 are situated at a vertical height  $Z$ . Then, advantageously, at least the contour of the drum interior does not have to be changed.

In contrast, the bores 4 are oriented differently, for example, in the circumferential direction, alternately diagonally upward and diagonally downward relative to the interior mouth, whereby at least the

discharge openings 10 of the orifice bodies 5 screwed into the bores 4 are situated at a different vertical height. For example, see planes E1, E2 Figure 2).

5           Such an embodiment is illustrated in Figures 2 and 3, among others. In this fashion, a greater vertical offset of the area of the discharge opening 10 is achieved than would be achieved as a result of the sole measure of the different orientation of the orifice body  
10 5 in the openings or bores 4. However, these two measures can naturally also be combined, so that, as required, they complement one another, in accordance with the present invention.

15           It is also advantageous for the discharge openings 10 to lead to the outside in an annular area 13 of the drum 1 in which the drum jacket has a completely or essentially constant diameter.

20           The scope of the invention as defined by the attached claims should not be limited by the specific embodiments set forth in the examples, but should be given the broadest interpretation consistent with the specification as a whole.

## List of Reference Symbols

	Separator drum	1
	Drum bottom part	2
5	Drum top part	3
	Bores	4
	Orifice body	5
	Recess	6
	Bore	7
10	Bore sections	8, 9
	Discharge opening	10
	Groove-type indentation	11
	Inlet openings	12
	Annular area	13
15		
	Planes	E1, E2
	Angle	$\alpha$
	Axis of rotation	A
	Vertical height	Z
20	Solids	S

## CLAIMS:

1. A centrifuge for isolating a solids phase, said centrifuge comprising:

a centrifugal drum rotatable about an axis of rotation, said centrifugal drum having an external surface and an internal surface which has a biconical configuration, said internal surface defining a largest inside diameter relative to said axis of rotation;

a separating disk stack comprising a separation disk being inserted in said centrifugal drum; and

a plurality of solids discharge orifices disposed around said largest inside diameter, each of said plurality of solids discharge orifices comprising a bore having an inlet opening at said internal surface and an associated discharge opening at said external surface;

wherein each of said inlet openings is disposed at said largest inside diameter of said centrifugal drum so as to define an inlet plane that is perpendicular to said axis of rotation; and

wherein each solids discharge orifice of said plurality of solids discharge orifices is configured to project from said associated discharge opening an associated stream of the solids phase in an associated stream direction and further configured according to at least one of the following configurations:

said solids discharge orifices are configured to direct the streams of the solids phase that are adjacent each other in different directions; and

said solids discharge orifices are configured to dispose said discharge openings that are adjacent each

other on different planes that are perpendicular to said axis of rotation.

2. The centrifuge of claim 1, said centrifuge being a continuously operating separator.

3. The centrifuge of claim 1 or 2, wherein said axis of rotation is a vertical axis of rotation.

4. The centrifuge of any one of claims 1 to 3, wherein said bores are oriented and aligned such that the solids phase exits from said associated discharge openings at least in two different directions.

5. The centrifuge of any one of claims 1 to 4, wherein each of said bores comprises a first bore section contiguous with a second bore section, wherein said first bore section extends along a radial axis perpendicular to said axis of rotation from said interior surface towards said external surface, and wherein said second bore section extends from said first bore section to said external surface at an angle with respect to said radial axis.

6. The centrifuge of any one of claims 1 to 5, wherein said external surface of said centrifugal drum defines for each of said discharge openings an associated recess for directing the associated stream of the solids phase exiting from said associated discharge opening in the associated stream direction at an associated angle with respect to a radial axis perpendicular to said axis of rotation.

7. The centrifuge of any one of claims 1 to 6, wherein said discharge openings are disposed in an annular area of a drum bottom part which has a constant diameter.

8. The centrifuge of any one of claims 1 to 7, wherein each of said plurality of solids discharge orifices is formed by an orifice body which is disposed within an opening extending from said internal surface to said external surface.

9. The centrifuge of any one of claims 1 to 8, wherein said discharge openings that are adjacent each other are disposed on different planes that are perpendicular to said axis of rotation.

10. The centrifuge of claim 9, wherein said discharge openings are situated in two or more distinct planes aligned perpendicularly to said axis of rotation.

11. The centrifuge of claim 9, wherein said discharge openings are situated alternately in two distinct planes aligned perpendicularly to said axis of rotation.

12. The centrifuge of claim 8, wherein said orifice bodies are non-uniformly disposed within their respective openings in such a manner that said associated discharge openings are disposed on at least two different planes which are perpendicular to said axis of rotation.

13. The centrifuge of any one of claims 1 to 12, wherein said discharge openings are alternately disposed on opposite sides of said inlet plane.

14. The centrifuge of any one of claims 1 to 13, wherein said solids discharge orifices are configured to direct the streams of the solids phase that are adjacent each other in different directions.

15. The centrifuge of any one of claims 1 to 8, wherein said discharge openings are disposed on a discharge plane that is perpendicular to said axis of rotation and said solids discharge orifices are configured to direct the streams of the solids phase in directions offset from said discharge plane.

16. The centrifuge of claim 15, wherein said discharge plane is said inlet plane.

17. The centrifuge of claim 15 or 16, wherein said bores are formed to direct the streams of the solids phase exiting said associated discharge openings in alternating directions diagonally to either side of said inlet plane.

18. A centrifuge comprising:

a centrifugal drum rotatable about a vertical axis, said centrifugal drum having an external surface and a single-conical or biconical internal surface, said internal surface defining a largest inside diameter; and

solids discharge orifices disposed in an area of said largest inside diameter, each of said solids discharge orifices comprising a bore having an inlet opening at said internal surface and an associated discharge opening at said external surface;

wherein, in a circumferential direction, said bores are alternately oriented diagonally upward and diagonally downward relative to said inlet openings.

19. The centrifuge of claim 18, said centrifuge being a continuously operating separator.

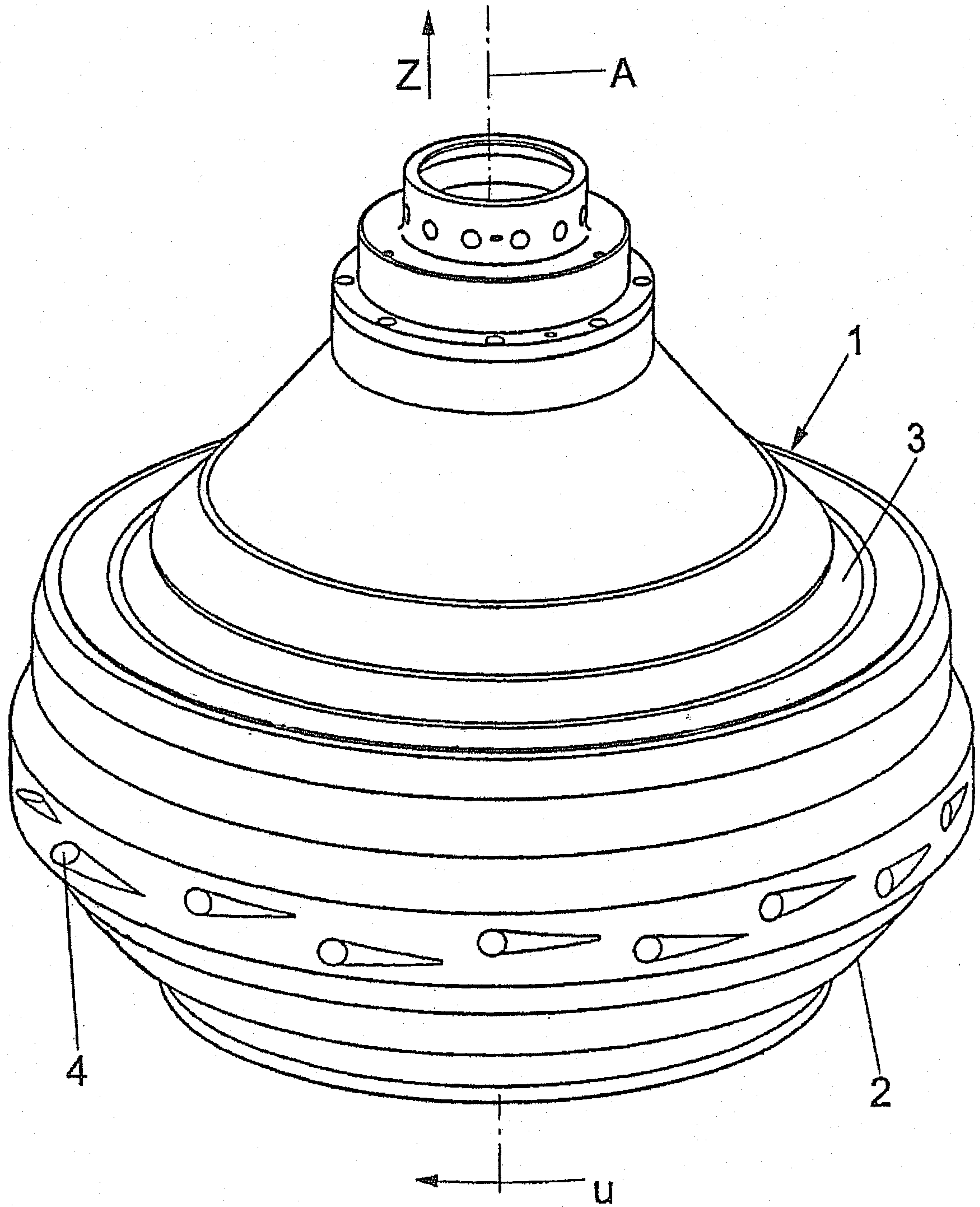

Fig. 1

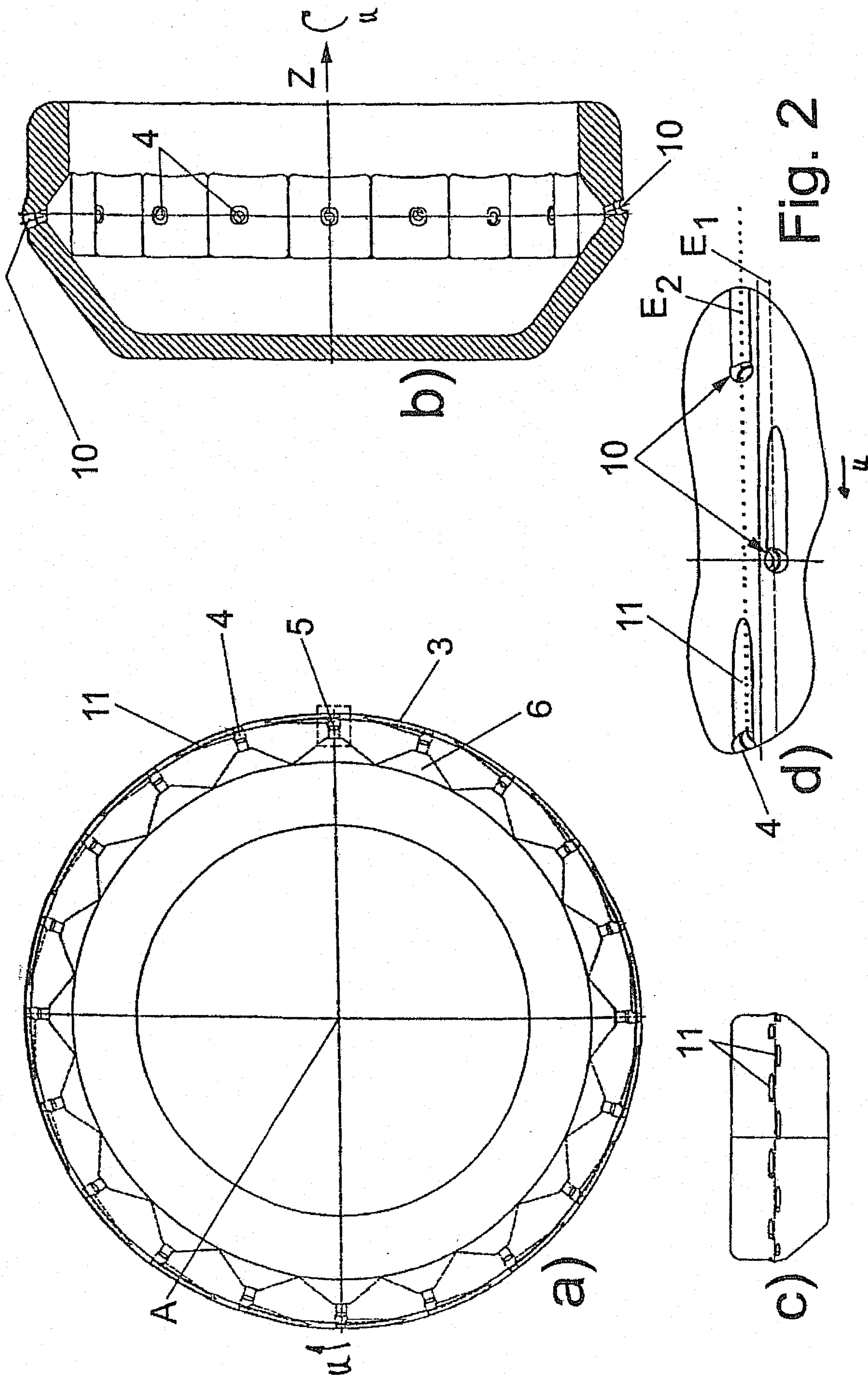

Fig. 2

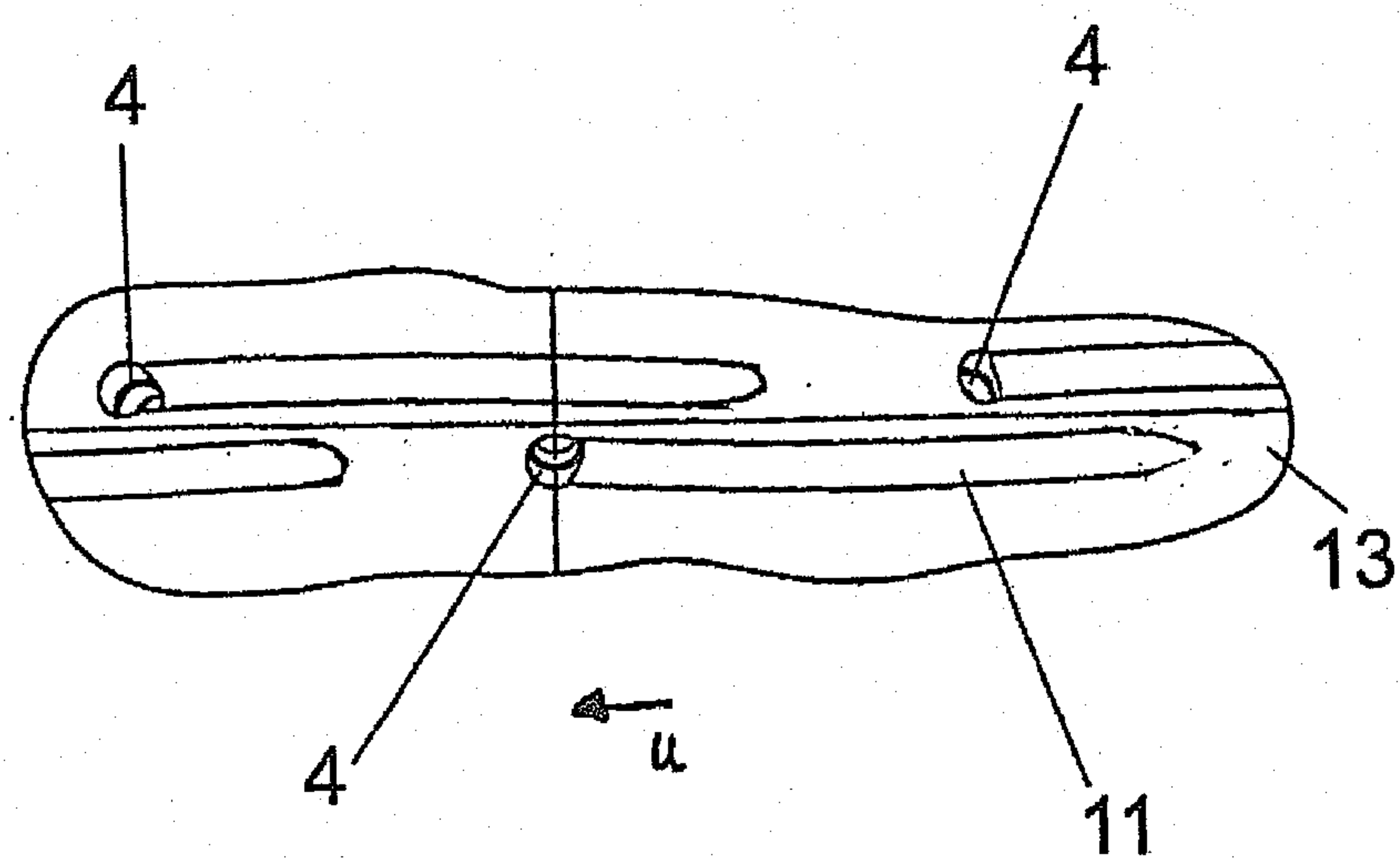
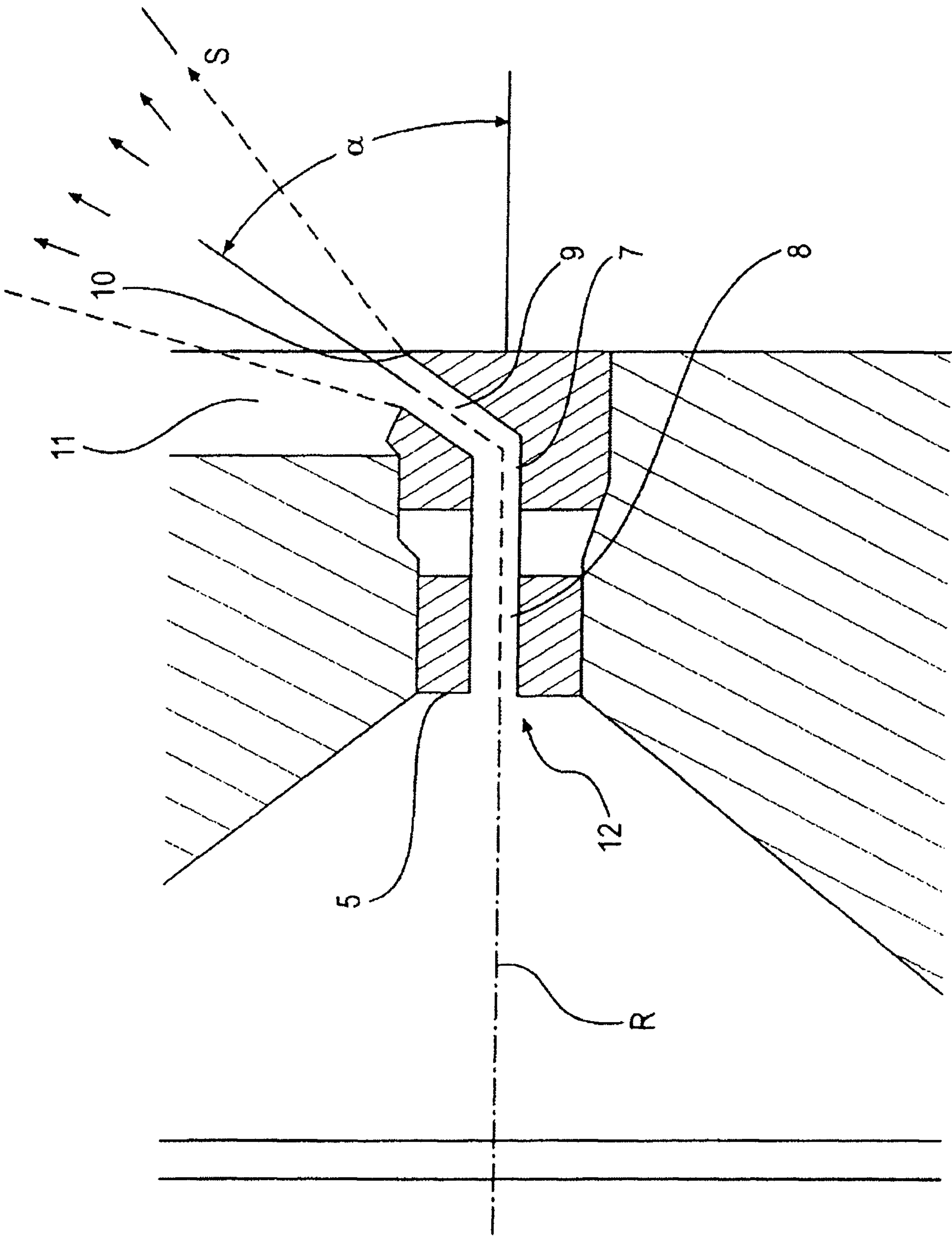

Fig. 3



**FIG. 4**

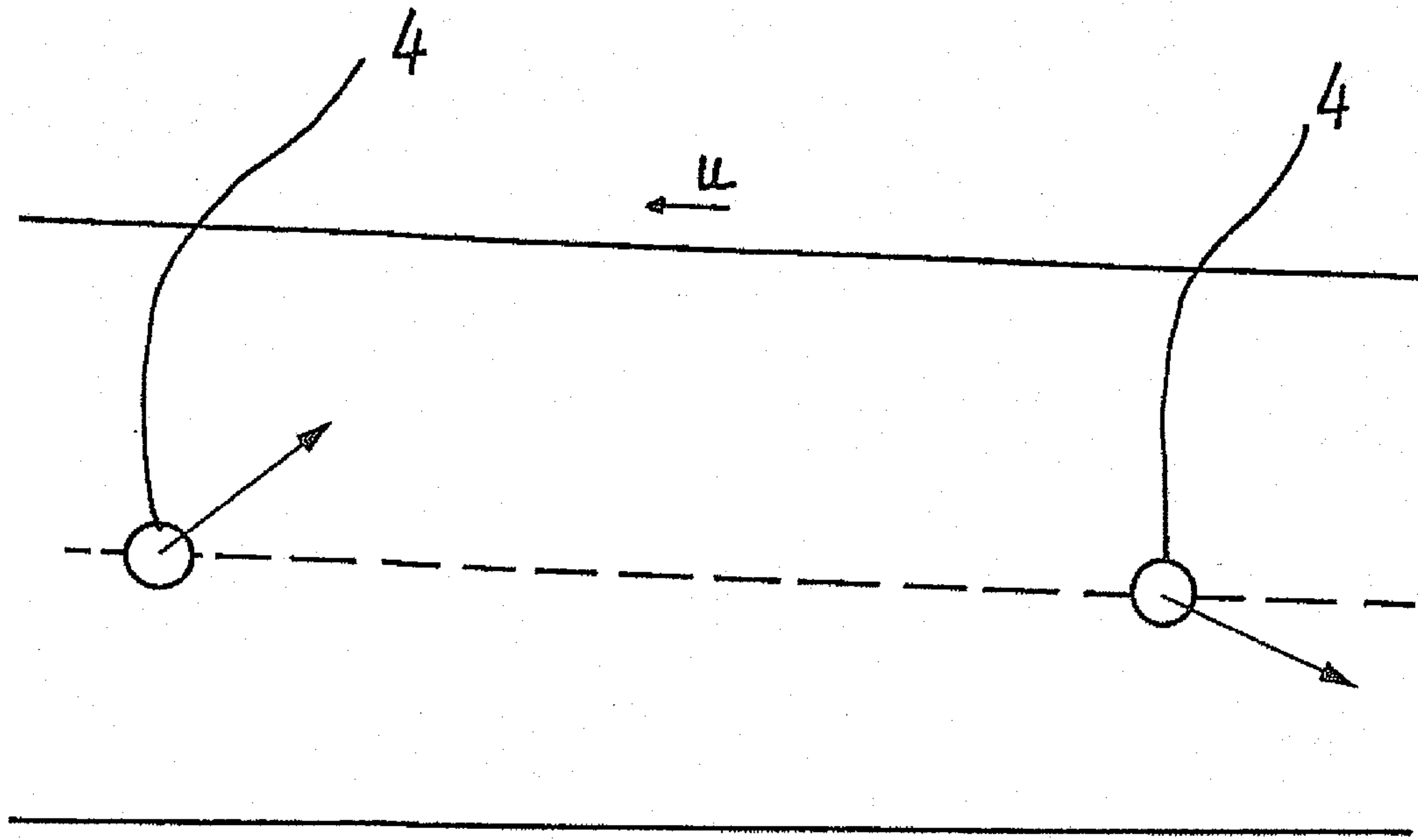

Fig. 5

