

D. ASHWORTH.

Molds for Molding Glass-Ware.

No. 129,306.

Patented July 16, 1872.

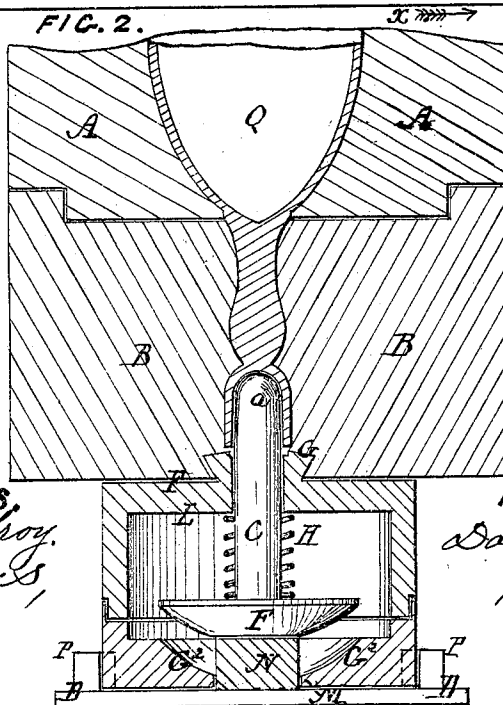
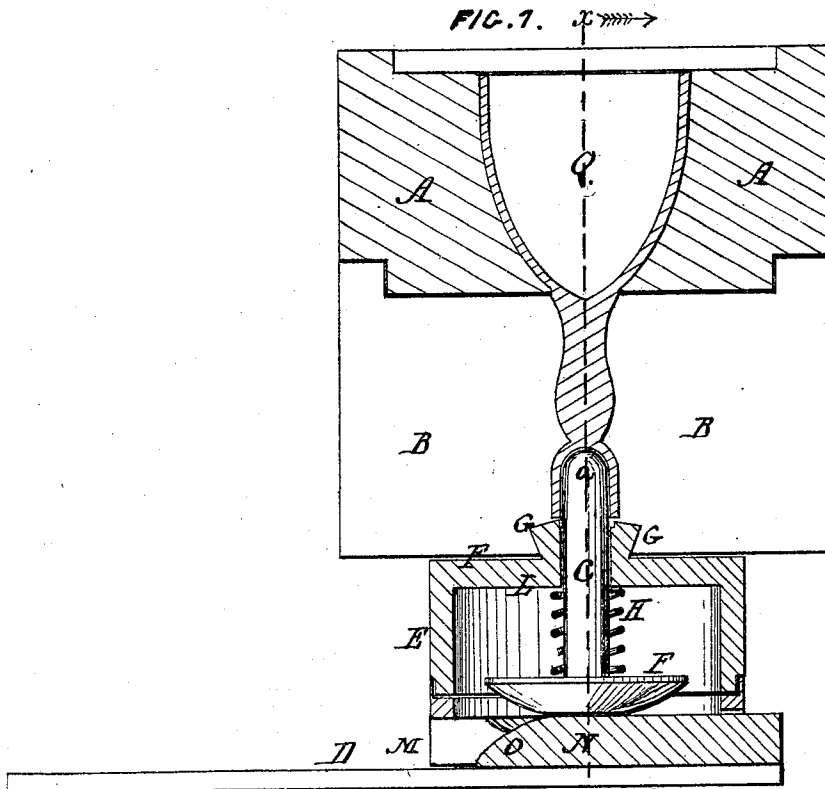

WITNESSES,  
*J. P. McCoy,*  
*J. P. McCoy,*

INVENTOR.  
*Daniel Ashworth*  
*per*  
*Brown Brothers*  
*Attorneys.*

# UNITED STATES PATENT OFFICE.

DANIEL ASHWORTH, OF EAST CAMBRIDGE, MASSACHUSETTS.

## IMPROVEMENT IN MOLDS FOR MOLDING GLASS-WARE.

Specification forming part of Letters Patent No. 129,306, dated July 16, 1872.

*To all whom it may concern:*

Be it known that I, DANIEL ASHWORTH, of East Cambridge, in the county of Middlesex and State of Massachusetts, have invented a new and useful Improvement in Molding Pressed Glass-Ware; and that the following is a full, clear, and exact description of the same, reference being had to the accompanying drawing.

This invention relates to molds for molding that class of pressed glass-ware requiring to be molded with a cavity in the lower end of the ware, as, for instance, door-knobs, goblets, &c., the molds for such purposes being provided with a movable plunger adapted to produce said cavity.

The invention consists of a movable plunger for glass-molds of the class to which this invention relates—that is, so arranged and so provided in connection with the platform on which the mold is slid into position under the plunger of the press, that the operation of sliding the mold into and out of the press moves the plunger in the one case into its position within the mold to produce the cavity desired, and in the other withdraws or allows it to withdraw therefrom.

In the accompanying drawing my improvement in molding pressed glass-ware is illustrated—

Figure 1 being a central longitudinal vertical section of a glass-mold and its platform, constructed according thereto. Fig. 2 is a central transverse vertical section, through mold and platform, in plane of line *xx*, Fig. 1.

A in the drawing represents the upper section, B the lower, and C the movable plunger, to a glass-mold of the class to which this invention relates. The construction of the two parts A and B, in the present instance shown as adapted for molding a goblet, is the same as in glass-molds now in use, and therefore needs no particular description herein. D, the table or platform on which the mold is slid into or out of the glass-press.

The plunger C and table D, under the present invention, are relatively constructed and arranged as follows:

E, a cylindrical-shaped case, adapted at its upper head F to receive the lower section B of the mold, which fits over the fixed beveled knob G at the center of the case E.

Through the center of this knob G the upper end *a* of the plunger C projects. This plunger C is within the body of the case E, and rests through a disk or flange, F, secured to it upon the floor G<sup>2</sup> of the case. This plate F is beveled upon its under face, and correspondingly thereto the seat for it on the floor G<sup>2</sup> is beveled. H, a spiral spring around plunger C. This spring H is confined on plunger between its flange F and the under side of the top L to the case E. M, a radial passage through bottom portion of case E, opening into the seat on floor G<sup>2</sup> for the plunger-flange F. N, a rib fixed to upper side of table D in the direction of its length. Over this rib, to bring the mold into position in the glass-press, the mold passes, the mold moving over the rib and receiving the same within the radial passage M to the case E, which passage M and rib N correspond in width. The end O of the rib N is beveled off, as shown in Fig. 1, the end O being the one first receiving the mold-carrying case E. P, stops fixed to platform. These stops are for arresting the mold as it is slid into the press at the proper place for the glass-press, through plunger Q thereof, to press a goblet, &c., within the mold. With a glass-mold having its plunger C arranged in combination with a table, D, having a rib, N, as described, it is obvious that in sliding the mold into the press over the rib N the plunger C will be raised and made to project the more into the lower section of the mold, and that sliding the mold out of the press the plunger, from its own gravity and force of spiral spring H, withdraws from the mold; this withdrawal of the plunger being permitted by the escape of the mold from the table-rib as the mold is moved away from the glass-press.

Thus it will be seen that by my invention the sliding of the mold into and out of the press secures the desired operation of the plunger, which heretofore has been accomplished by a separate and independent movement of the molder.

The advantages of the present improved arrangement for operating the plunger C are obvious, and therefore need no particular mention herein.

The spring H, for the plunger C, may be dispensed with, but it is best to use it, as it

secures a more positive withdrawal of the plunger.

Although I have herein particularly described one arrangement of parts by which the plunger C, through moving it into and out of position within the glass-press, is suitably operated, I do not intend to limit myself to any one arrangement of parts for accomplishing the same through the movement of the mold into and out of the press; for, outside of the present arrangement and construction of parts, the movement of the plunger can be accomplished by constructing the case E in two parts, so that one can be turned upon or within or outside of the other, as the mold was slid into and out of position for the glass-press, by and through the meshing of a gear-wheel thereon with a toothed rack-bar on the table, in combination with a connection between the part of the case so revolved and the plunger, that as the case

was rotated to cause a raising and lowering of the plunger.

Having thus described my improvement in molding pressed glass-ware, I shall state my claim as follows:

A mold for molding pressed glass-ware, in which a plunger C is constructed and arranged substantially as described, in combination with the table D constructed with a rib N or otherwise, substantially as herein described, to operate the said plunger C, for the purpose specified.

The above specification of improvements in molding glass-ware signed by me this 8th day of January, A. D. 1872.

DANIEL ASHWORTH.

Witnesses:

EDWIN W. BROWN,  
ALBERT W. BROWN.