

A. WENNING & C. H. GÉGAUFF.

COMBING MACHINE.

(Application filed Apr. 2, 1902.)

(No Model.)

FIG. 1.

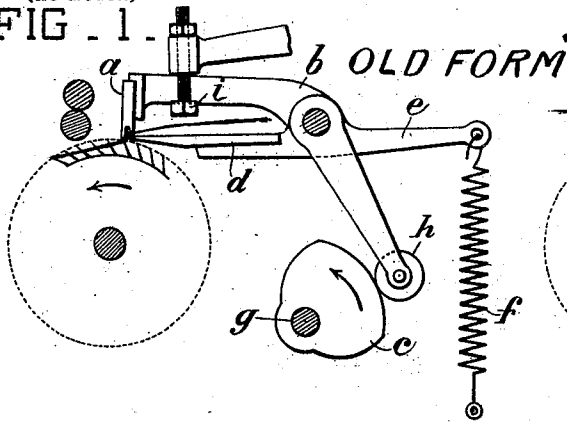

FIG. 2.

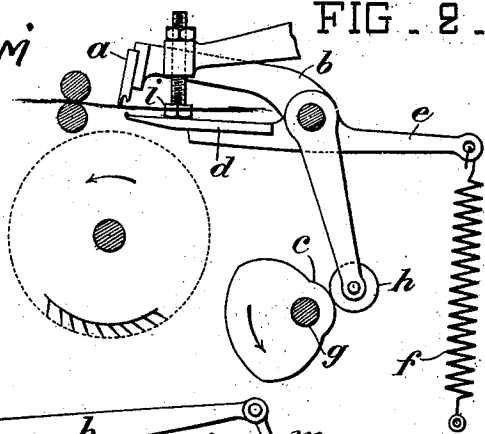

FIG. 3.

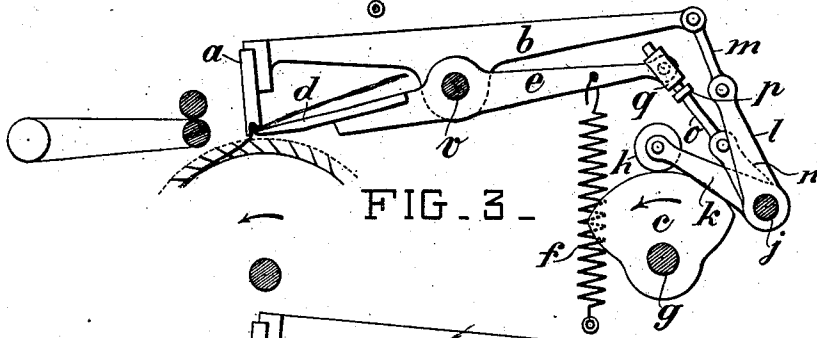

FIG. 4.

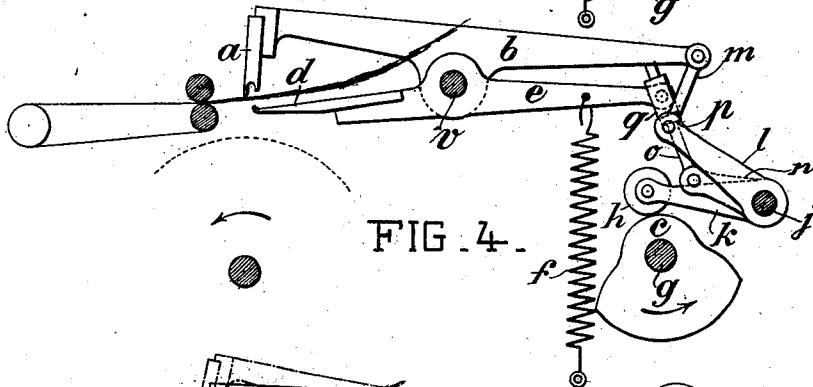
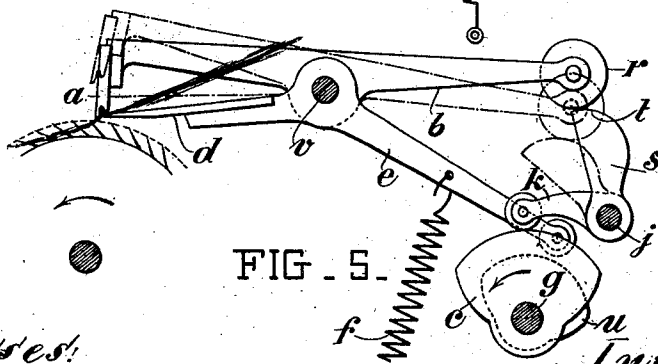

FIG. 5.



Witnesses:

J. H. Wiman
H. J. Leonard

Inventors:

Alfred Wenning
Charles H. Gégauff
 by *Henry Connelley*
 Attorney

UNITED STATES PATENT OFFICE.

ALFRED WENNING AND CHARLES HUBERT GÉGAUFF, OF MÜLHAUSEN, GERMANY, ASSIGNORS TO SOCIÉTÉ ALSACIENNE DE CONSTRUCTIONS MÉCANIQUES, OF MÜLHAUSEN, GERMANY, A FIRM.

COMBING-MACHINE.

SPECIFICATION forming part of Letters Patent No. 712,222, dated October 28, 1902.

Application filed April 2, 1902. Serial No. 101,037. (No model.)

To all whom it may concern:

Be it known that we, ALFRED WENNING and CHARLES HUBERT GÉGAUFF, subjects of the Emperor of Germany, and residents of Mülhausen, Alsace, Empire of Germany, have invented certain new and useful Improvements in Combing-Machines, of which the following is a full, clear, and exact specification.

In the known Heilmann combing-machines, where the motion of the supplying-nippers is vertical or approximately vertical to the circumference of the comb-cylinder, there is the drawback that it is not possible to give the nippers for the combing the desired proximity to the comb-cylinder as soon as the machine acquires a greater speed. It is especially the vibratory movements of the shaft bearing the cam-disk and the resultant wear on this cam which prevent the nippers being brought close to the combing-cylinder. In order to obviate this defect, according to the present invention a mechanism is interposed between the upper jaw of the nippers to be driven and the driving-cam, which mechanism is constructed so that it assumes a dead-point position in the position in which the combing is to take place, and consequently trifling variations in the position of the driving-eccentric do not cause any alteration in the position of the nippers.

Figures 1 and 2 of the accompanying drawings show, respectively, two different positions of the mechanism hitherto used for actuating the nippers. These figures are employed for the purpose of illustrating the difference between the former or known construction and the novel construction illustrated in the remaining figures of the drawings. Figs. 3 and 4 illustrate the new actuating mechanism in two positions. Fig. 5 shows a modification thereof.

In combing-machines hitherto known (see Figs. 1 and 2) the nippers were operated by setting the lever *b*, bearing the upper jaw *a*, in oscillating motion directly from a cam *c*. The lever *e*, bearing the lower jaw *d*, is controlled by the spring *f*, which tends to keep the nippers closed. If the machine works at

great speed, it is impossible to avoid the shaft *g*, bearing the cam *c*, acquiring a vibratory motion, which during the combing is transmitted to the nippers *a d*, so that the latter strike against the spikes of the comb-cylinder and injure it unless the distance at which the nippers approach the comb-cylinder be made correspondingly greater initially. This distance increases still more when the cam *c* and the roller *h*, rolling thereon, have become worn, whereby undulating motions occur, which increase the risk of damage. Vibratory motions are further produced by the upper jaw *a* when the nippers close, striking violently against the lower jaw *d*, resting against the stopping-screw *i*. As this blow takes place shortly before the nippers are moved close to the comb-cylinder, the vibrations caused by the jar also affect the combing.

In the new device, Figs. 3 and 4, the cam *c* does not act directly on the nipper-lever *b*, but on an arm *k*, pivoted on a fixed pivot *j*, which arm is firmly connected with a second arm *l*, which is pivotally connected by means of a bar *m* with the lever *b*. A third arm *n* is firmly connected with the arms *k* and *l*, which engages with a pusher-bar *o*. This pusher-bar *o* has a collar *p* and engages with its free end in a socket *q*, pivotally arranged on the end of the nipper-lever *e*.

In the position shown in Fig. 3, in which the combing is effected, the cam *c* acts with its largest radius on the arm *k*, the toggle-joint formed by the parts *l* and *m* is extended, and the nippers are as close as possible to the comb-cylinder. If now vibratory movements of the shaft occur which are transmitted by the cam *c* to the roller *h* and arm *k* they cannot affect the lever *b*, and consequently the nipper-jaw *a*, as the distance of the end of the lever *b* from the shaft *j* cannot be increased. Moreover, it is impossible for the vibratory motions of the shaft *g* to affect the nearer approach of the nippers to the comb-cylinder, as the movement of the arm *l* by the said vibratory motion is too slight to transmit any amount of the motion to the lever *b*. Moreover, the undulating movements which are caused owing to the wear between

the parts *c* and *h* cannot, therefore, be transmitted to the nippers.

When the nippers close—that is, on the device moving out of the position shown in Fig. 4 into that shown in Fig. 3—the arm *n* revolves with the arm *k* to the right. The collar *p* on the bar *o* thereby moves upward and presses up the socket *q*, so that the lever *e* carries out such a swinging motion that the jaw *d* moves down. It is therefore impossible for the upper jaw when it moves down to strike violently against the lower jaw, as it has to move after the latter in order to effect the closing of the nippers. When the nippers are closed, the socket *q* raises itself from the collar *p*, so that during the combing the lever *e*, and consequently the lower nipper-jaw, remains unaffected by the vibratory movements transmitted to the arm *n*. When the nippers open, the socket *q* again moves without any jar on the collar *p*, as the two parts move hereby in the same direction, but with different speed.

In the modification shown in Fig. 5 the toggle-joint *m l* is replaced by a roller *r* and a cam *s*, which at its highest part *t* is rounded off into the arc of a circle. This form of the cam *s* equally insures against the shaking motions of the parts *g*, *c*, and *k* being able to be transmitted to the lever *b*. The compulsory movement of the lever *e* for avoiding the jar when the nippers close can be effected in any suitable manner that may be preferred. For instance, it can be produced by a cam *u* acting directly on the end of the lever *e*. When the nippers are closed and have moved close to the comb-cylinder, the free end of the lever is raised from the cam *u*, while the spring *f* holds the nippers closed.

In the constructions illustrated it is assumed that the pivot *v* for the nipper-jaw levers *b e* is firmly fixed in the frame. The invention, however, also admits of being applied with advantage to machines in which said pivot is movable in a horizontal or vertical direction. Also to avoid the jar when closing the nippers the closing motion can be imparted separately to each of the jaws.

What we claim is—

1. A device for operating the supplying-nippers of a Heilmann combing-machine, comprising the nipper-jaws, a driving-cam for the upper nipper-jaw, and locking mechanism between the latter and said cam which assumes a dead-point position when the nippers

approach the comb-cylinder, substantially as and for the purposes set forth.

2. A device for operating the supplying-nippers of a Heilmann combing-machine, comprising the nipper-jaws, a driving-cam for the upper jaw, a locking mechanism between said jaw and cam which assumes a dead-point position when the nippers approach the comb-cylinder, and a mechanism which imparts a movement to the lower jaw in the same direction as, but slower than that of the upper jaw, when the nippers close.

3. A device for operating the supplying-nippers of a Heilmann combing-machine, comprising the nipper-jaws, a driving-cam for the upper jaw, and a toggle-joint connected with said jaw and actuated by said cam, said toggle-joint being extended when the nippers are in the combing position.

4. A device for operating the supplying-nippers of a Heilmann combing-machine, comprising the nipper-jaws, a driving-cam for the upper jaw, locking mechanism between the latter and said cam which, when the nippers are close to the comb-cylinder, assumes a dead-point position, a spring controlling the lower jaw, a lever movable with said intermediate mechanism, and a pusher-bar between said lever and the lower jaw, and acting on the latter against said spring, whereby said lower jaw moves in the same direction as the upper jaw but at less speed.

5. A device for operating the supplying-nippers of a Heilmann combing-machine, comprising the nipper-jaws, a driving-cam for the upper jaw, a toggle-joint, one part of which is coupled to the upper jaw and the other part to a pivot, a lever-arm on said pivot, which arm is under the direct control of said cam, a second lever-arm on said pivot, a pusher-bar coupled to this second lever-arm, which bar extends loosely through a socket on the lower jaw and is provided with a pusher-collar, and a draw-spring which acts on the lower jaw and tends normally to close it, substantially as set forth.

In witness whereof we have hereunto signed our names, this 19th day of March, 1902, in the presence of two subscribing witnesses.

ALFRED WENNING.

CHARLES HUBERT GÉGAUFF.

Witnesses:

GEO. GIFFORD,
AMAND RITTER.