



- (51) International Patent Classification: Not classified
- (21) International Application Number: PCT/NL2014/050424
- (22) International Filing Date: 26 June 2014 (26.06.2014)
- (25) Filing Language: Dutch
- (26) Publication Language: English
- (30) Priority Data: 2011070 29 June 2013 (29.06.2013) NL
- (71) Applicant: ACK IP B.V. [NL/NL]; Staarten 14, NL-5281 PL Boxtel (NL).
- (72) Inventor: TEULING, DEN, Adrianus Wilhelmus Marius; M.F. Elkerbout 9, NL-5626 GG Eindhoven (NL).
- (74) Agent: VERHEES, Godefridus Josephus Maria; De Pinckart 54, NL-5674 CC Nuenen (NL).
- (81) Designated States (unless otherwise indicated, for every kind of national protection available): AE, AG, AL, AM, AO, AT, AU, AZ, BA, BB, BG, BH, BN, BR, BW, BY,

BZ, CA, CH, CL, CN, CO, CR, CU, CZ, DE, DK, DM, DO, DZ, EC, EE, EG, ES, FI, GB, GD, GE, GH, GM, GT, HN, HR, HU, ID, IL, IN, IR, IS, JP, KE, KG, KN, KP, KR, KZ, LA, LC, LK, LR, LS, LT, LU, LY, MA, MD, ME, MG, MK, MN, MW, MX, MY, MZ, NA, NG, NI, NO, NZ, OM, PA, PE, PG, PH, PL, PT, QA, RO, RS, RU, RW, SA, SC, SD, SE, SG, SK, SL, SM, ST, SV, SY, TH, TJ, TM, TN, TR, TT, TZ, UA, UG, US, UZ, VC, VN, ZA, ZM, ZW.

- (84) Designated States (unless otherwise indicated, for every kind of regional protection available): ARIPO (BW, GH, GM, KE, LR, LS, MW, MZ, NA, RW, SD, SL, SZ, TZ, UG, ZM, ZW), Eurasian (AM, AZ, BY, KG, KZ, RU, TJ, TM), European (AL, AT, BE, BG, CH, CY, CZ, DE, DK, EE, ES, FI, FR, GB, GR, HR, HU, IE, IS, IT, LT, LU, LV, MC, MK, MT, NL, NO, PL, PT, RO, RS, SE, SI, SK, SM, TR), OAPI (BF, BJ, CF, CG, CI, CM, GA, GN, GQ, GW, KM, ML, MR, NE, SN, TD, TG).

Published: — without international search report and to be republished upon receipt of that report (Rule 48.2(g))



WO 2014/209122 A2

(54) Title: ROLLER CONVEYOR

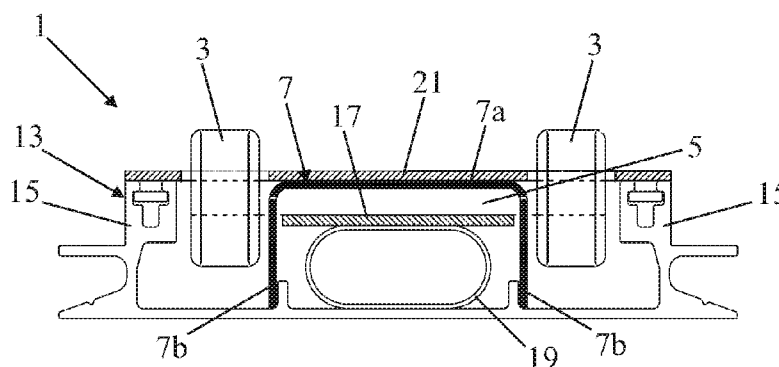

FIG. 2

(57) Abstract: A roller conveyor I has a number of pairs of rollers present in a path, of each pair both rollers 3 are present on a common shaft 5. This shaft is fixed in the direction of transport in a U-shaped profile 7. For this purpose, the side portions 7b of the U-profile are provided with vertical slots and in the main portion 7a of the U-profile a further slot is present which connects the two side slots with one another. The shaft protrudes with both ends through the slots present in the side parts. The rollers are located on the ends of the shaft and are present adjacent to the U-profile. Under the shafts 5 a support plate 17 is present, including a lifting mechanism provided for lifting of the shafts. This lifting mechanism has an inflatable flexible hose 19 which can lift the supporting plate. Moreover, on the U-profile 7 a top plate 21 is present which is attached to the further profile 13.

Roller conveyer

DESCRIPTION:

5

**Field of the invention**

The invention relates to a roller conveyer comprising a U-profile with shafts at a mutual distance from each other and fixed in the direction of transport, each of which bearing at least one roll, as well as a lifting mechanism which is present under the U-profile for the lifting of the shafts, which roller conveyer further comprises a further profile which is open at the top and in which the U-profile is present, said further profile has two side walls on which an upper plate is attached. The top plate forms a floor and acts as a shielding of the rollers from dirt, and is provided with holes for the passage of the rollers.

**State of the art**

Such a roller conveyer is generally known. In the known roller conveyer the free edges of the U-profile stab upwards and on each shaft one roller is present, which is located between the side portions of the U-profile. Hereby, the U-profile with the shafts and rollers can be lifted in its entirety. This famous roller bar takes some height.

25 **Summary of the Invention**

An object of the invention is to provide a roller conveyer of the type described in the preamble with a smaller overall height than the well-known roller conveyer. For this purpose, the roller conveyer according to the invention is characterized in that the U-profile is present in the further profile with the free edges of the side portions facing downwards, and that on each shaft, a further roller is present, wherein in the side portions of the U-profile vertical slots are present through which the shafts are stabbing, and wherein the rollers are present near the outer side of the side

portions of the profile, and a support plate is present under the shafts on which the shafts rest, and the lifting mechanism is located under the support plate, wherein in the main portion of the U-profile a further slot is present which connects the two side slots with each other, and a top plate is present on the U-profile. By applying a U-profile in a convenient manner for fixing the shafts in the direction of transport and for guiding the shafts in height, and by resting the shafts together on a vertically movable support plate, a structure with low build-in height is obtained.

The lifting mechanism is preferably designed such that it can move the shafts between a lower position in which the rollers do not project above the upper plate and an upper position in which the rollers protrude above the top plate.

A favorable embodiment of the roller conveyor according to the invention is characterized in that the lifting mechanism comprises an inflatable flexible hose which is present under the support plate.

A further favorable embodiment of the roller conveyor according to the invention is characterized in that the shafts are locked up in the axial direction with a small clearance between the side walls of the further profile. This avoids the rollers to run off the shafts and thus the rollers do not need to be fixed on the shafts.

### **Brief description of the drawings**

Below, the invention will be elucidated on the basis of an exemplary embodiment shown in the drawings of the roller conveyor according to the invention. In these drawings:

Figure 1 shows an embodiment of the roller conveyor according to the invention with the rollers in the lowered position;

Figure 2 shows the roller conveyor shown in Figure 1 with the rollers in a raised position; and

Figure 3 shows the U-profile of the roller conveyor shown in Figure 1.

### **Detailed description of the drawings**

In Figures 1 and 2 an embodiment of the roller conveyor according to the invention is shown with the rollers in the lowered respectively raised position. The

roller conveyor 1 has a number of pairs of rollers present in a path, of each pair both rollers 3 are present on a common shaft 5. This shaft is fixed in a U-shaped profile 7 in the direction of transport. For this purpose, the side portions 7b of the U-profile are provided with vertical slots 9, see Fig 3, and in the main portion 7a of the U-profile a further slot 11 is present which connects the two side slots with one another. The shaft protrudes with both ends through the slots present in the side portions 9. The rollers are located on the ends of the shaft and are present near the outer side of the side portions of the U-profile.

The U-profile 7 is present in a further profile 13 which is open at the top, see Figures 1 and 2. This further profile has two side walls 15. The U-profile 7 is present in the further profile 13 with the free edges of the side portions 7b facing downwards. The shafts 5 is locked in the axial direction with a small clearance between the upper parts of the side walls 15 of the further profile.

Under the shafts 5 a support plate 17 is present on which the shafts rest. Under this support plate a lifting mechanism for lifting the shafts is present. This lifting mechanism has an inflatable flexible hose 19 which is present under the support plate. Moreover, on the U-profile 7 a top plate 21 is present which is attached to the further profile 13.

The lifting mechanism can move the shafts 5 between a lower position, see figure 1, in which the rollers 3 do not protrude above the upper plate 21, and an upper position, as shown in Figure 2, in which the rollers 3 do protrude above the top plate 21.

Albeit the invention has been described in the foregoing based on the drawings, it should be observed that the invention is not by any manner or means restricted to the embodiment shown in the drawings. The invention also extends to all embodiments deviating from the embodiment shown in the drawings within the scope defined by the claims.

CLAIMS:

1. Roller conveyor (1) comprising a U-profile (7) with shafts (5) at a mutual distance from each other and fixed in the direction of transport, each of which bearing at least one roll (3), as well as a lifting mechanism which is present under the U-profile for the lifting of the shafts, which roller conveyor further comprises a further profile (13) which is open at the top and in which the U-profile (7) is present, said further profile has two side walls (15) on which an upper plate (21) is attached, characterized in that the U-profile (7) is present in the further profile (13) with the free edges of the side portions (7b) facing downwards, and that on each shaft, a further roller is present, wherein in the side portions (7b) of the U-profile vertical slots (9) are present through which the shafts are stabbing, and wherein the rollers are present near the outer side of the side portions of the profile, and a support plate (17) is present under the shafts on which the shafts rest, and the lifting mechanism is located under the support plate, wherein in the main portion (7a) of the U-profile a further slot (11) is present which connects the two side slots (9) with each other, and a top plate (21) is present on the U-profile.
2. Roller conveyor (1) as claimed in claim 1, characterized in that the lifting mechanism may move between a lower position in which the rollers (3) do not project above the upper plate (21) and an upper position in which the rollers or the shafts (5) protrude above the top plate.
3. Roller conveyor (1) as claimed in claim 1 or 2, characterized in that the lifting mechanism is an inflatable flexible hose (19) which is present under the support plate (17).
4. Roller conveyor (1) as claimed in claim 1, 2 or 3, characterized in that the shafts (5) are locked up in the axial direction with a small clearance between the side walls (15) of the further profile (13).

1 / 1

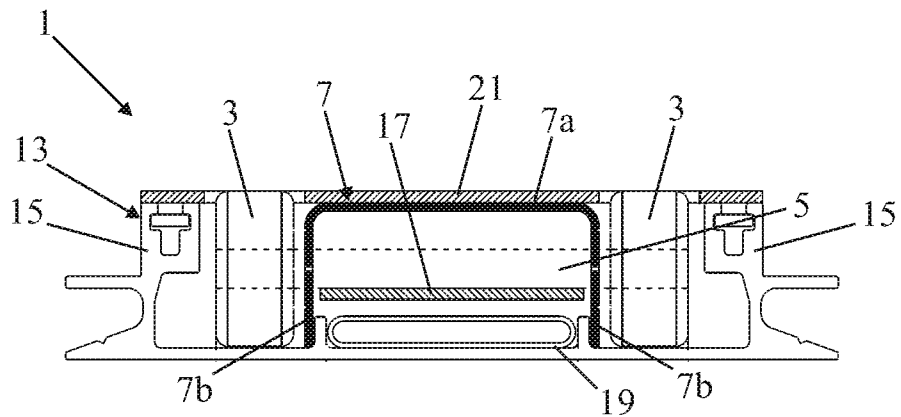

FIG. 1

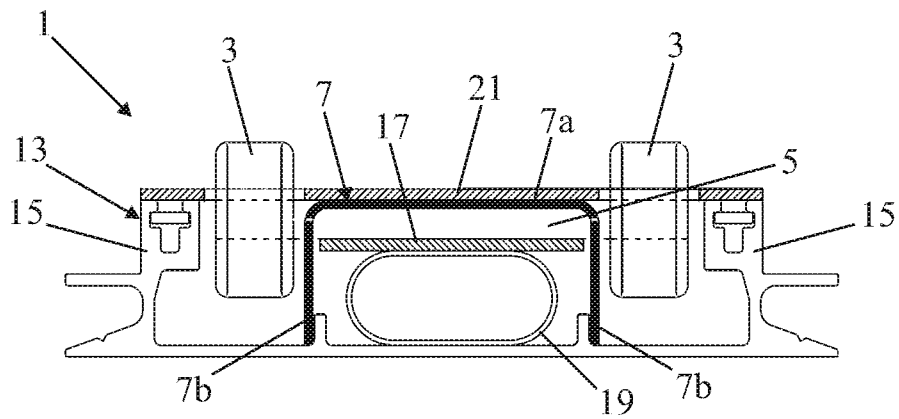

FIG. 2

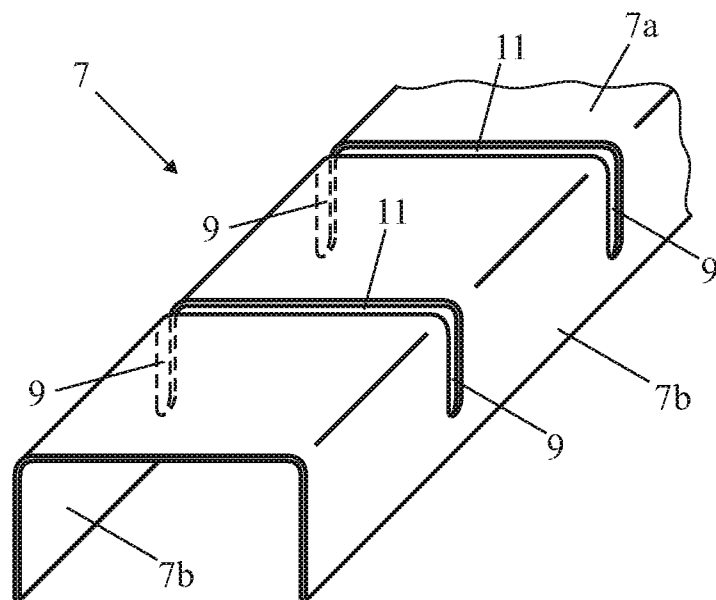

FIG. 3