

March 9, 1937.

A. FELIN

2,073,366

THIN RUNPROOF GARTER HOOK

Filed Nov. 30, 1935

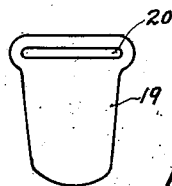
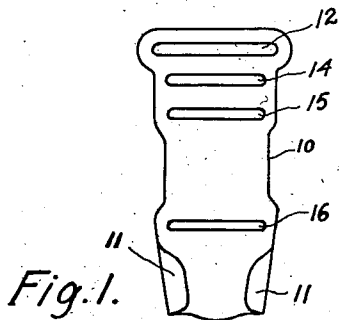

Fig. 1.

Fig. 2.

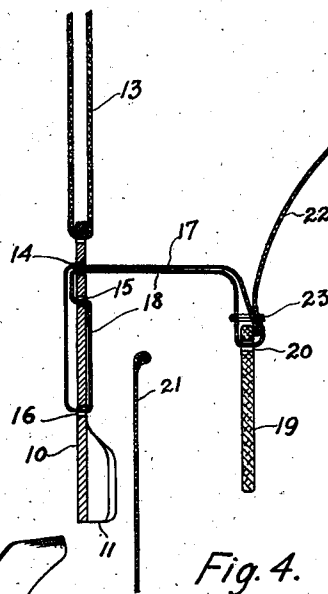
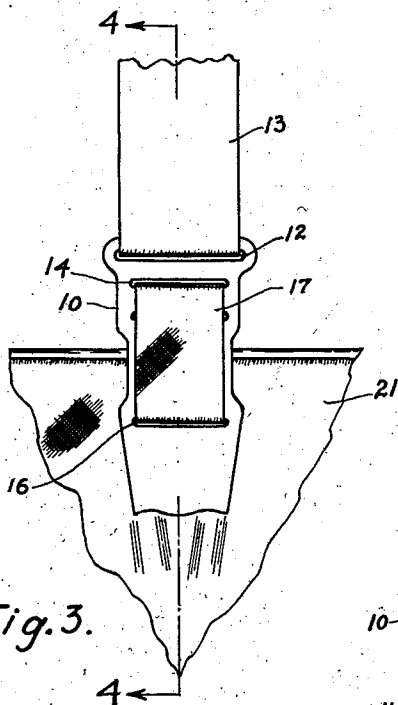

Fig. 3.

Fig. 4.

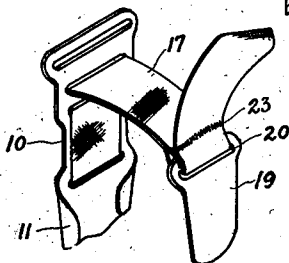

Fig. 5.

Anton Felin  
By M. Björndal  
Attorney

# UNITED STATES PATENT OFFICE

2,073,366

## THIN RUNPROOF GARTER HOOK

Anton Felin, Newark, N. J.

Application November 30, 1935, Serial No. 52,315

2 Claims. (Cl. 24—263)

My invention relates to improvements in garter hooks and the like for supporting garments, stockings, etc. The garter as a means of supporting clothing has been known for a very long time. It originated as a simple band around the leg and was in modern times improved with mechanical clasps and hooks for quick fastening and unfastening. Through many changes the garter hook as commonly used at present was finally developed in the form of a button member on one side and a loop or hook member on the other side of the garment to be supported. With the increasing use of silk hose, however, the button member often became undesirable due to its tendency to tear the supported material and thus, for instance, produce a run. Due to its required length and bulkiness it is furthermore objectionable as it is uncomfortable when the person wearing the garter is in a sitting position, the button will also be visible as a lump through thin outer garments. The reason why runs are produced in thin silk stockings being that said objectionable button member grips the fabric at two points very close together and thus strains are produced sufficient to break the threads.

To eliminate the objectionable features of the button member various attempts have been made with different types of fastening members, see U. S. Patents Nos. 720,742; 738,775; 1,197,878 and also British Patent No. 24,864. All these show wedge shaped fastening members with a corresponding sheath or socket similar in form, but not in construction; to that disclosed in the present application. All these patents, however, have wedge members of various types which all will lock and tear the hose. There is further the fundamental difference that these known garter hooks all have the wedge member in front leaving a metallic surface in the rear which may touch the skin of the wearer. All these objections have been eliminated in the present invention in that the relative position of the wedge and sheath has been reversed. Furthermore the present invention discloses a new and improved method of flexibly connecting the wedge and sheath members. Through this new construction the metallic surfaces of the sheath are furthermore covered by the connecting strap. In modern quantity production the practicability of the article stands or falls on the latter item alone.

The objects of the present invention are therefore: First—to provide a garter hook which will grip the fabric over a relatively large surface, thus preventing runs; second—to provide a garter hook which is thin and comfortable to wear,

and third—to provide a garter hook which may be manufactured at a low cost. Other objects of my invention will be evident from the following specification and claims.

I attain these objects by means as illustrated in the drawing where:

Fig. 1 is a rear elevation of the sheath or socket member.

Fig. 2 is an elevation of the wedge member.

Fig. 3 shows a front elevation of the assembled garter hook in operable engagement with the supported hose.

Fig. 4 is an expanded section taken along line 4—4 in Fig. 3.

Fig. 5 is a perspective view of the garter hook assembled, but with the wedge removed from the sheath.

Similar numerals refer to similar parts throughout the several views.

Referring to Fig. 1 the sheath member 10 is a metallic punching having two ears 11 bent over to form a downward converging sheath. At the upper end of said sheath member 10 there is a transverse slot 12 for the main supporting strap 13, see Figures 3 and 4. Other transverse slots 14, 15 and 16 in said sheath member 10 are provided for the connecting straps 17 and 18 shown in Figures 4 and 5.

The wedge member 19 is made of fibrous material and has a downwardly converging wedge shape with a transverse slot 20 for said connecting straps 17 and 18 at its upper end. In Figures 3 and 4 is indicated how a section of the hose 21 is placed between the wedge member and the sheath member, the wedge being pressed into the soft material while the sheath is drawn upwardly over the wedge and enclosing the material in a tight grip.

In Figures 4 and 5 is shown how the connecting straps, or wedge supporting straps, 17 and 18 are placed in relation to members 10 and 19. The upper strap 17 terminates at the hole 20 of wedge member 19 and continues from there through slot 14 in member 10 to slot 16 in the same member. From transverse slot 16 the same strap continues on the inside of member 10 to slot 15, passing out through this slot and returning as strap 18 through slot 14 to slot 20 in member 19. The strap 18 next goes through slot 20 and terminates in the wedge release strap 22. A seam 23 joins straps 17, 18 and 22 at the top end of wedge member 19. Through this arrangement of straps 17 and 18 one piece of webbing and one seam provides covering on both sides of the metallic member 10, a connecting strap to wedge

member 19 and finally a wedge releasing strap 22. This being particularly important for the low cost manufacture of the article.

The operation of my invention is simple and evident from the foregoing description. As indicated in the several figures the material to be supported 21 is wedged between members 10 and 19 in a manner to give support over a relatively large surface, thus preventing runs. The member 19 as shown in Fig. 2 is of a particularly suitable rounded shape to prevent tearing of the supported fabric. Said member 19 being inserted in the sheath formed by ears 11 of member 10, the downwardly converging wedge shape of both sheath and wedge insuring a good grip. The release of the wedge is effected by pulling strap 22.

It will be seen that there has been provided a simple, inexpensive, dependable and yet uniquely formed thin run-proof garter hook, generally of a novel and valuable type, and well calculated to attain the various objects and advantages of the invention. While various particulars of description, as to materials, parts and shapings and connections and relations of parts have been hereinabove detailed, this has been done in aid of disclosing as clearly as possible an embodiment of the invention as now preferred; and it is to be understood that these can be varied within the appended claims which define the scope of protection contemplated.

I claim as new and desire to secure by Letters Patent of the United States:

1. In a garter hook the combination of a front sheath member having four transverse slots and having its lower opposite longitudinal edges projecting inward to form a sheath receptacle of

downwardly converging wedge form, a hose supporting strap placed through the topmost of said transverse slots; a wedge member of fibrous material having a transverse slot at the upper end of a downwardly converging wedge shaped tongue; a double wedge-member supporting strap both webs of which extend through the second topmost transverse slot of said sheath member, the loop of said wedge member supporting strap extending with one web inwardly through each of the remaining two transverse slots in said sheath member.

2. In a garter hook the combination of a front sheath member having four transverse slots and having its lower opposite longitudinal edges projecting inward to form a sheath receptacle of downwardly converging wedge form, a hose supporting strap placed through the topmost of said transverse slots; a wedge member of fibrous material having a transverse slot at the upper end; a double wedge member supporting strap both webs of which extend through the second topmost transverse slot of said sheath member, the loop of said wedge member supporting strap extending with one web inwardly through each of the remaining two transverse slots in said sheath member; a wedge releasing strap formed of one end of said double wedge member supporting strap, said wedge releasing strap being pulled through the transverse slot of said wedge, the other end of said double wedge member supporting strap extending to the upper end of said wedge and being joined there with one seam to said wedge releasing strap and to the other web of the same strap.

ANTON FELIN.