

(No Model.)

2 Sheets—Sheet 1.

A. N. WOODARD.
BELT LINE PACKAGE AND CASH CARRIER.

No. 524,626.

Patented Aug. 14, 1894.

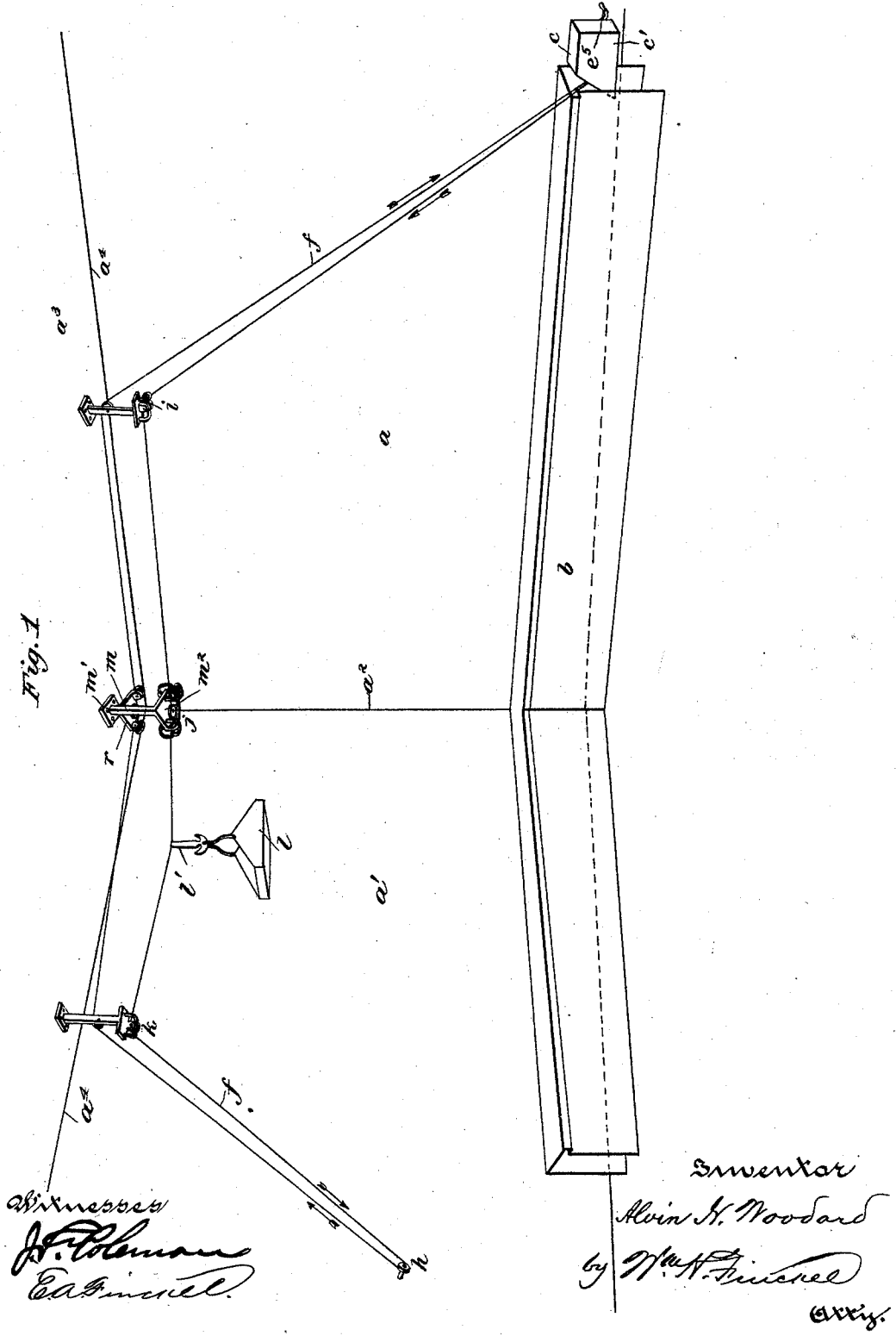

Fig. 1

Witness
J. P. Tolman
Ed. Smith.

Inventor
Alvin N. Woodard
by W. H. Finckel
atty.

(No Model.)

2 Sheets—Sheet 2.

A. N. WOODARD.
BELT LINE PACKAGE AND CASH CARRIER.

No. 524,626.

Patented Aug. 14, 1894.

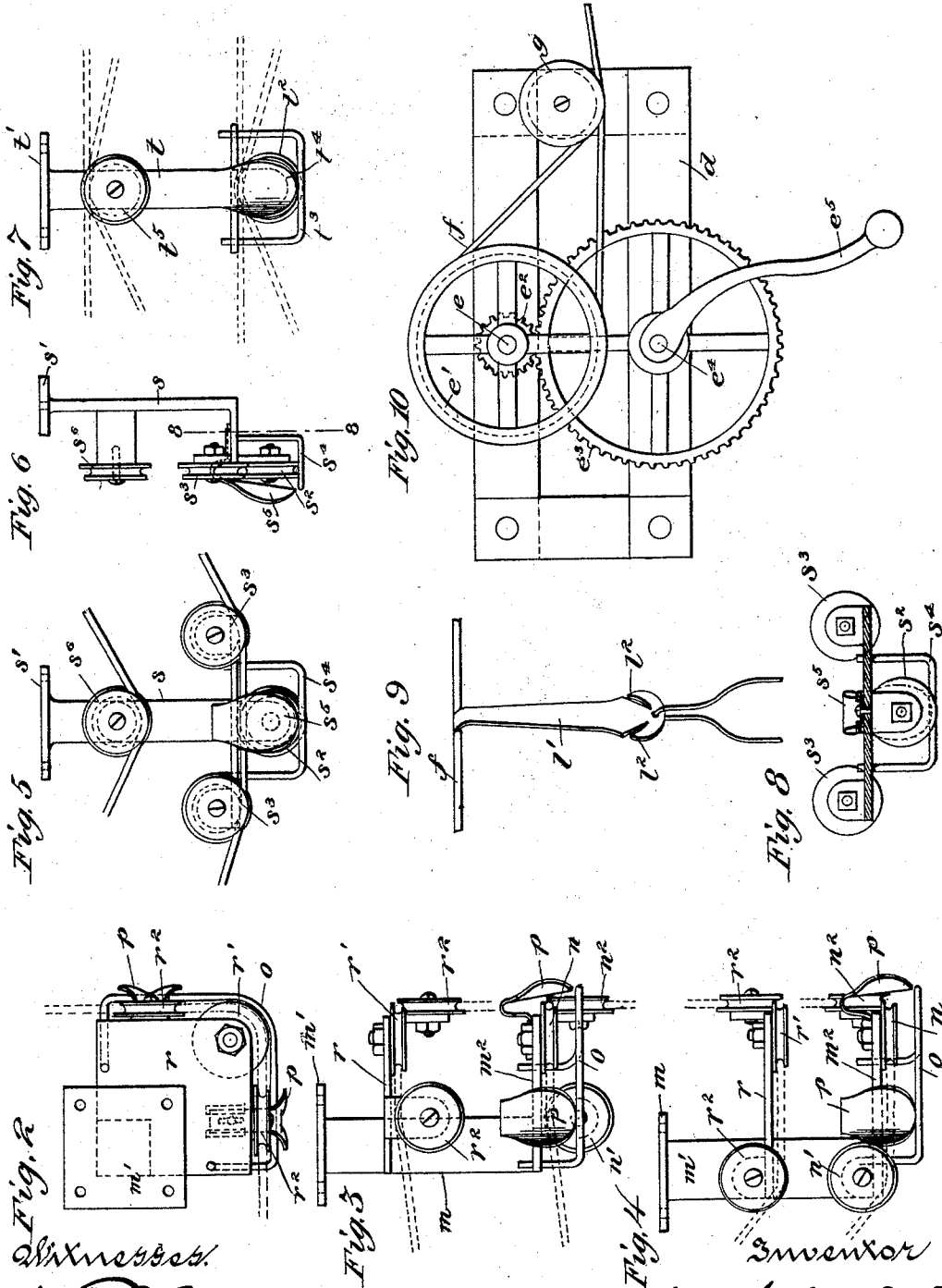

Witnesses:
J. F. Coleman
Ed. Simmel

Inventor
Alvin N. Woodard
by W. F. Simmel
att'y.

UNITED STATES PATENT OFFICE.

ALVIN N. WOODARD, OF MANSFIELD, OHIO.

BELT-LINE PACKAGE AND CASH CARRIER.

SPECIFICATION forming part of Letters Patent No. 524,626, dated August 14, 1894.

Application filed February 5, 1894. Serial No. 499,145. (No model.)

To all whom it may concern:

Be it known that I, ALVIN N. WOODARD, a citizen of the United States, residing at Mansfield, in the county of Richland and State of Ohio, have invented a certain new and useful Improvement in Belt-Line Package and Cash Carriers, of which the following is a full, clear, and exact description.

This invention relates to apparatus for use in stores and elsewhere for conveying parcels or packages or cash from one place to another.

One object of the invention is to avoid the complicated mechanism usually employed in apparatus of this general character and to reduce the cost of installing the apparatus so as to render the apparatus available in many places where the cost of a common apparatus is so excessive as to be prohibitive.

I have designated my apparatus a belt-line parcel and cash carrier, for the reason that I employ an endless belt for the transmitting medium. This belt or band may be a cord or wire rope or other convenient medium, and it is arranged at one end upon a power drum, and thence is led over suitable guide pulleys to a pulley or drum which forms its other terminal. The carrier for conveying the parcel or cash is made fast to the belt or band and travels with it; and the guide pulleys are provided with means for directing the carrier past them and for preventing the said belt or band from jumping the pulleys.

Having thus stated generally the principle of my invention, I will proceed now to set forth the best mode in which I have contemplated applying that principle and then will particularly point out and distinctly claim the part, improvement or combination which I claim as my invention.

In the accompanying drawings illustrating my invention, in the several figures of which like parts are similarly designated, Figure 1 is a perspective view of an interior having my apparatus installed. Fig. 2 is a top plan view of one of the corner guides. Fig. 3 is a side elevation of one form of corner guide for use where the band or belt passes thence downwardly. Fig. 4 is a similar view of a corner guide where the band or belt passes thence upwardly. Fig. 5 is a front elevation of a side guide having the band arranged thereon to pass thence upwardly. Fig. 6 is a side ele-

vation of the guide shown in Fig. 5. Fig. 7 is a front elevation of a side guide showing the band arranged to pass thence horizontally or downwardly. Fig. 8 is a cross-section taken in the plane of line S—S, Fig. 6. Fig. 9 is a perspective view of the carrier hanger, and Fig. 10 is a side elevation of the motor.

The letter *a* may represent one side of a room or store, and *a'*, the side at an angle thereto, and *a²* the corner or angle between said sides; *a³*, the ceiling, and *a⁴*, *a⁴*, the ceiling lines.

b is a counter extending along the two sides of the room.

c is the motor arranged beneath the counter and readily accessible to an attendant behind the counter. The preferred form of this motor is shown in detail in Fig. 10, and it consists of a frame *d* of any suitable construction which receives and supports a shaft *e*, upon which is mounted a drum *e'*, about which is passed the endless band or belt *f*. This drum is fixed to the said shaft and rotates with it and said shaft is rotated by means of its pinion *e²* which meshes with a driving gear wheel *e³* mounted upon a shaft *e⁴*, which shaft also has bearings in the frame *d*; and this shaft *e⁴* is provided with a crank handle *e⁵*, by means of which power is applied to the driving wheel *e³*. This motor mechanism as thus described may be inclosed in a case *c'* of any suitable construction and material. The belt or band *f* passes from the case beneath a guide roller or rollers *g*, mounted to turn freely in the frame *d*. The other end of the belt or band is supported upon or about a pulley or drum *h* which is arranged at a wrapping counter or platform or in the cashier's compartment, or other convenient place in the store or elsewhere where the apparatus is employed. The band *f* passes from the motor upwardly to a side guide roller or rollers *i*, thence to the corner guide rollers *j*, thence to side rollers *k*, whence it passes to the supporting pulley or drum *h*, in such manner that the parcel or cash carrier *l*, securely fastened to the band or belt by means of a hanger *l'* fixed to said band or belt, may be conveyed from the counter where the motor is located to the wrapping counter or counting house or cashier's compartment, where the end pulley or drum *h* is arranged, and thereafter, by re-

versing the movement of the motor, may be caused to travel back again to the point whence it started.

It will be observed that the band or belt does not have a continuous travel in one direction, but travels back and forth by reversal of the motor. Of course, any other motor may be employed in this connection than that I have just described, but I prefer the described motor because of its simplicity and economy, and, in point of fact, it has been demonstrated to be perfectly efficient for the purposes of this invention.

I design by my invention to convey parcels from one pound upwardly, and the apparatus will be installed with a band or belt and fixtures sufficient to sustain the weight of the largest bundles ordinarily made up in the business in which the apparatus is used.

Referring now to the various guide rollers, I have shown in Fig. 2 a corner guide roller which is provided with a post m , having a foot or flange m' , by which it may be screwed to the ceiling. This post is provided with a lower bracket m^2 , in which is arranged a horizontal, grooved pulley n at the angle of the bracket and two vertical, grooved pulleys n' and n^2 , whose peripheries are in the same plane as the periphery of the horizontal pulley.

A guide rod o depends from the bracket m^2 and extends horizontally across the sides of the pulleys n' , n^2 , and outwardly curved shields p overhang the three several pulleys. These shields p may be bolted to the brackets or they may be secured thereto by joints similar to those ordinarily employed in connecting stove legs to their stove bases.

The rod o and the shields p serve, respectively, to prevent the hanger l' from striking the journals of the pulleys and to guide the said hanger around the pulleys, and prevent the belt or band from jumping the said pulleys. As illustrated in Fig. 3, the belt or band passes over the top of the pulleys and so may extend thence horizontally or in a downward direction.

When the band is to pass horizontally around the pulleys and then upwardly, the pulleys n' , n^2 will be arranged so that their lower peripheries will be in the plane of the peripheries of the horizontal pulleys, as illustrated in Fig. 4. In each of these corner guide-pulley devices, there is also a bracket r , which is provided with a horizontal grooved pulley r' , and two side grooved guide pulleys r^2 , r^3 , about which the upper member of the band or belt is passed.

The two brackets and the post and its foot or flange may be made of a single casting, or otherwise constructed, as convenience and economy may require.

In the form of side guide device shown in Fig. 5, I employ a post s having a fastening foot or flange s' , the central grooved guide pulleys s^2 and the side guide pulleys s^3 , the guide rod or bar s^4 , and the shield s^5 and the

upper guide pulley s^6 , corresponding essentially in construction and function with similar parts in the guide pulley devices already described and illustrated in Figs. 2, 3 and 4. Such a side guide device as is shown in Figs. 5, 6 and 8 will be useful in connection with the belt or band that first descends to it and then ascends from it, or vice-versa.

The side guide device shown in Fig. 7 comprises a post t having a foot or flange t' for securing it in position, a single grooved guide pulley t^2 , guide bar t^3 , shield t^4 and upper grooved guide pulley t^5 substantially as illustrated, and such a side guide device is useful especially in connection with a belt or band which reaches it from below and thence descends.

Guides constructed in substantial conformity with these several forms will be found sufficient to support and properly guide a transmitting band in the various turns it may be compelled to take in passing from one portion of a place to another at various inclinations and elevations and angles.

As already intimated, the carrier hanger l' is made fast to the band or belt and travels with it. For convenience of those storekeepers and others who employ a device for transmitting a parcel or package carrier and who desire also to attach a cash carrier, I have provided the said hanger with hooks l^2 to which such cash carriers may be connected. But I do not wish to be limited in this case to any particular form of parcel or cash carrier and reserve the right for the purpose of my invention to use such cash and parcel carriers as will best subserve the purpose of the person for whom the apparatus is installed.

I have thus described that form of my invention which may be installed in a store in a very economical manner, but it is obvious that the invention is capable of considerable expansion and extension.

What I claim is—

1. The combination of a motor having a band-supporting and driving drum, a supporting drum at a distance therefrom, an endless band or belt arranged upon said drums and adapted to be moved back and forth by said motor, and suitable guide pulleys for said endless band or belt arranged to support the band or belt in its passage from the motor drum to the other drum at various inclinations and angles, a carrier fixed to said band and supported solely by it, and a guide bar and shields on each of said guide pulleys to direct the carrier about the said guide pulleys and prevent the band or belt from jumping the said pulleys, substantially as described.

2. A belt or band guiding device for belt-line package and cash carriers, comprising a post having a foot or flange by which it may be secured in position, a suitable number of guide pulleys, a guide bar about said pulleys, and a shield overhanging one or more of said pulleys, to receive one member of the endless band or

belt, and a pulley arranged above the first named pulleys to receive the other member of the band or belt, substantially as described.

3. In a belt-line package and cash carrier, 5 an endless band or belt and a guiding device therefor, comprising a post having a foot or flange for securing it in position, a bottom bracket provided with a horizontally arranged 10 grooved pulley at the angle, and vertically arranged grooved pulleys, at the sides, a guide bar crossing the vertical pulleys, and shields overhanging the several pulleys, and an upper 15 bracket also provided with a horizontal grooved pulley at the angle and vertical grooved pulleys at the sides, substantially as and for the purpose described.

4. A belt or band guiding device for belt-line package and cash carriers, comprising a

post having a foot or flange by which it may be secured in position, a suitable number of 20 guide pulleys, a guide bar about said pulleys, and a shield overhanging one or more of said pulleys, to receive one member of the endless band or belt, and a pulley arranged above 25 the first named pulleys to receive the other member of the band or belt, combined with such band or belt, a carrier applied thereto, and a motor for such band or belt, substantially as described.

In testimony whereof I have hereunto set 30 my hand this 3d day of February, A. D. 1894.

ALVIN N. WOODARD.

Witnesses:

WM. H. FINCKEL,
HARRY Y. DAVIS.