

April 7, 1964

H. M. HILL

3,128,032

DISPENSING CONTAINER AND ONE PIECE BLANK

Filed Aug. 1, 1962

3 Sheets-Sheet 1

Fig. 1

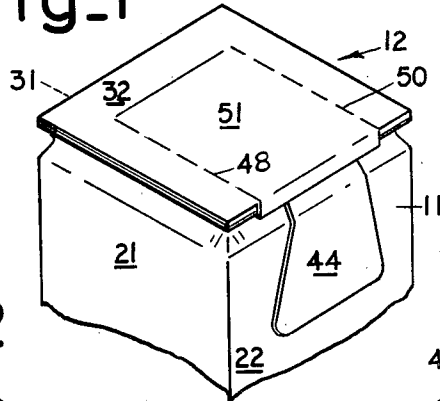

Fig. 4

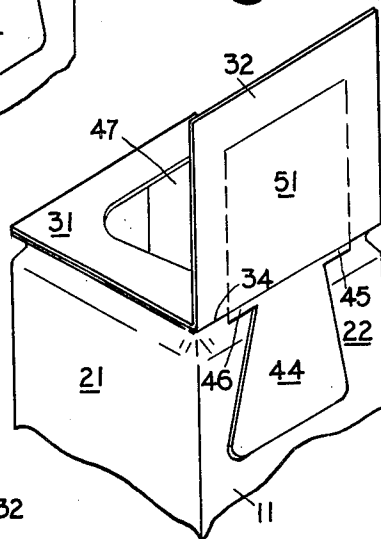

Fig. 2

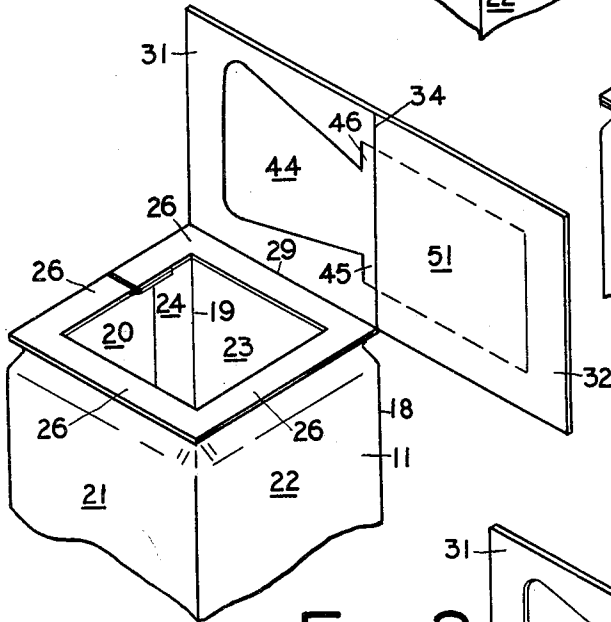
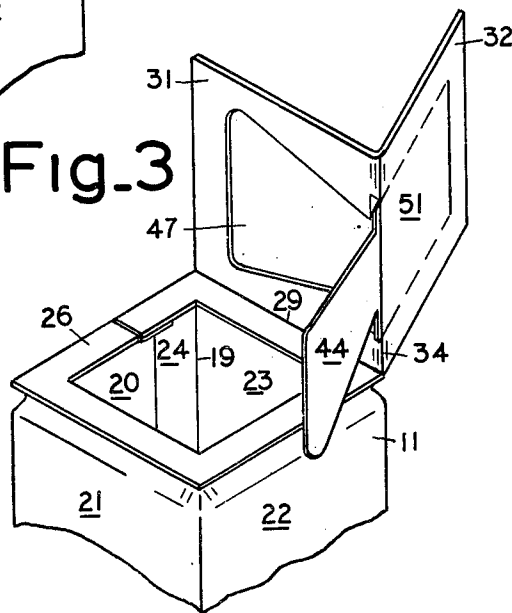

Fig. 3



April 7, 1964

H. M. HILL

3,128,032

DISPENSING CONTAINER AND ONE PIECE BLANK

Filed Aug. 1, 1962

3 Sheets-Sheet 2

Fig. 5

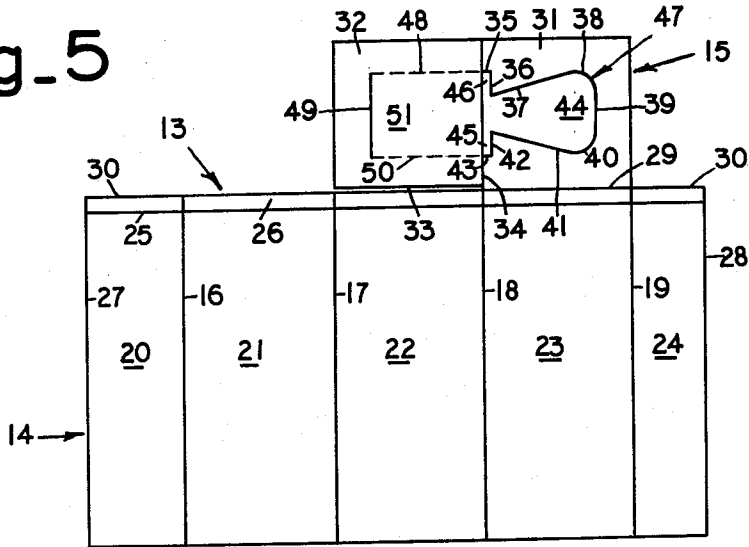

Fig. 6

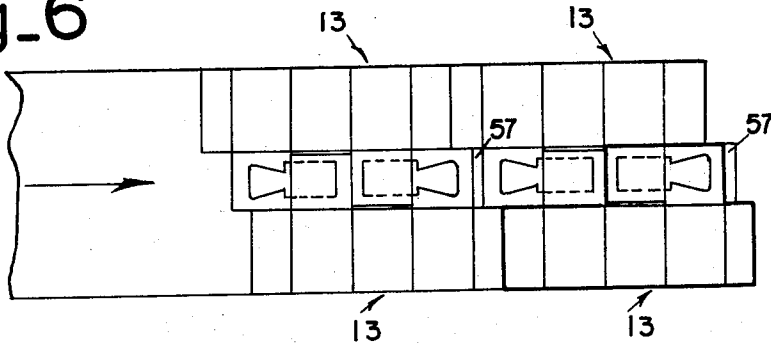
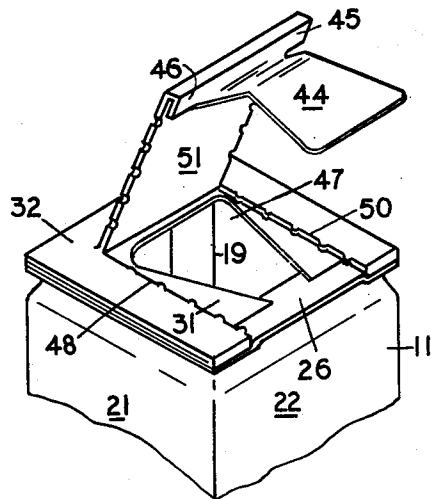

Fig. 7



April 7, 1964

H. M. HILL

3,128,032

DISPENSING CONTAINER AND ONE PIECE BLANK

Filed Aug. 1, 1962

3 Sheets-Sheet 3

Fig-8

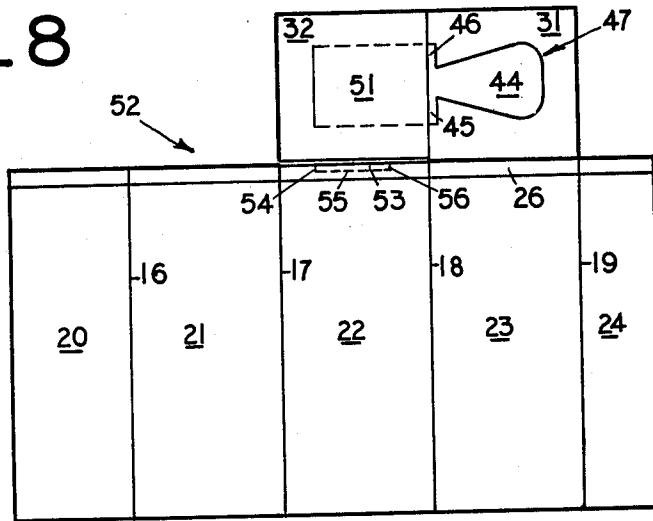
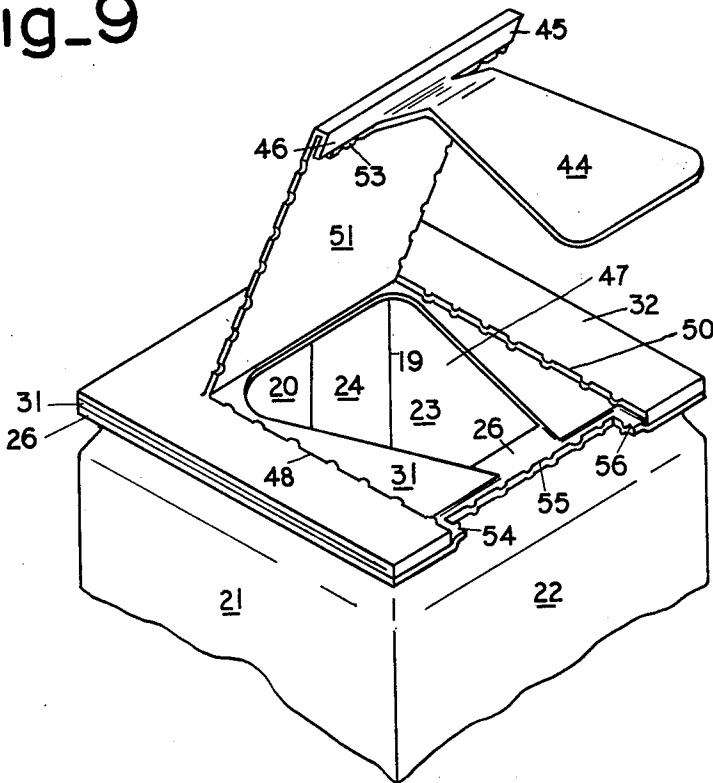

Fig-9



1

**3,128,032**  
**DISPENSING CONTAINER AND ONE**  
**PIECE BLANK**

Howard M. Hill, Hamilton, Va.  
 Filed Aug. 1, 1962, Ser. No. 214,058  
 16 Claims. (Cl. 229-17)

This invention relates to sanitary containers for the packaging and delivery of liquids such as milk and has particular reference to a dispensing container adapted to be rapidly made from a unitary blank and having a dispensing opening in its top, easily exposed by manipulating a tear tab and strip.

In some respects this container represents an improvement upon my prior disclosure under Serial No. 82,029 entitled Dispensing Container now covered by United States Patent No. 3,047,200.

An object of the invention is economy of material through a novel method of cutting a tear strip and tab.

Another object of the invention is economy of material because of an efficient layout of blanks.

Another object is achievement of high speed set up of containers in a dairy through simplified operations.

Another object is provision of a container having a flat top and complete sanitary protection of all filling and pouring surfaces.

Another object is provision of a container that is easily opened and tightly reclosed by finger manipulation.

Yet another object of the invention is simplification of fabricating machinery through the use of a unitary blank of a design easily and quickly set up in a packing plant such as a dairy.

Numerous other objects and advantages of the invention may be apparent as it is better understood from the following description which, taken in connection with the accompanying drawings, discloses a preferred embodiment thereof.

Referring to the drawings:

FIGURE 1 is a perspective view of the upper end of a completed and filled container made in accordance with this invention with the lower end broken away.

FIGURE 2 is a perspective view of the upper end of the container of FIGURE 1 after a first folding and gluing operation to make up the tubular body and a necking-in operation to turn out the end seam flanges.

FIGURE 3 is a perspective view of the upper end of the container after a second folding operation to clear the tear tab from the inner ply of the top closure in preparation for gluing down the inner ply.

FIGURE 4 is a perspective view of the upper end of the container after the operation of gluing down the inner ply to the end seam flanges leaving the container in condition for filling.

FIGURE 5 is a plan view of a blank from which the container of the instant invention may be made, the bottom closure features not shown.

FIGURE 6 is a partial plan view, to a smaller scale, of a web of paper showing four of the blanks of FIGURE 5 in staggered arrangement to minimize waste.

FIGURE 7 is a perspective view of the upper end of the container of FIGURE 1 opened for dispensing the contents, the lower end of the container broken away.

FIGURE 8 is a plan view of an alternative blank construction from which the container of the instant invention may be made.

FIGURE 9 is a perspective view, to a larger scale, of the upper end of a container made from the blank of FIGURE 8 and opened for dispensing the contents, the lower end of the container broken away.

As a preferred embodiment of the instant invention FIGURES 1 to 7 inclusive of the drawings illustrate a

2

container of rectangular cross section and a blank from which it may be readily and economically made. The container is comprised of tubular fibre body 11 closed at its upper end by a flat two-ply filling and dispensing top closure 12. The bottom end of the container may be closed in any suitable manner. FIGURES 8 and 9 illustrate a second form of the invention made from a modified body blank.

Referring to FIGURE 5, blank 13 is comprised of a major area 14 and an elongated flap 15. The major area 14 is divided by vertical score lines 16, 17, 18, and 19 into five wall panel forming areas 20, 21, 22, 23, and 24. A horizontal score line 25 sets off end seam flange area 26 extending from one vertical edge 27 of major area 14 to the other vertical edge 28. In FIGURE 2, panels 20, 21, 22, 23, and 24 make the walls of body 11; and area 26 makes up the end seam flange on all four sides at the upper end of each wall panel. In FIGURE 5, elongated flap 15 is hingedly articulated to the end seam flange area 26 immediately above panel 23 in a score line 29 which is co-extensive with upper edge 30 of major area 14. Elongated flap 15 is divided into two rectangles of substantially equal areas by vertical score line 34 which is co-extensive with score line 18. These areas form inner ply 31 and outer ply 32 of top closure 12 (FIGS. 1 and 2). Outer ply 32 stands directly above panel 22 (FIG. 5) and is separated therefrom by cut line 33 which is co-extensive with upper edge 30 and score line 29. Within inner ply 31 a line, defined by a horizontal cut 35, a vertical cut 36, an angular cut 37, a circular cut 38, a vertical cut 39, a circular cut 40, an angular cut 41, a vertical cut 42, a horizontal cut 43 and a portion of vertical score line 34 intersecting the end of cut line 35, outlines a tear tab 44 with protecting members 45 and 46 (FIGS. 1, 5, and 7). The opening 47 in inner ply 31 defined by this same outline becomes the filling opening (FIG. 4) and the dispensing opening (FIG. 7). Within outer ply 32 a horizontal weakened score 48 co-extensive with cut 35, a vertical score 49, and a horizontal weakened score 50 define a tear strip 51 leading from tear tab 44.

FIGURE 6 illustrates a method of staggering blanks in a web layout for efficiency and shows four blanks 13 and scrap 57. It will be noted that the efficiency of this layout produces only one small piece of scrap 57 for each two blanks produced.

To make up the container the blank 13 (FIG. 5) is wrapped about a mandrel of proper shape and side seamed as in FIGURE 2. In this same operation it is desirable to complete the bottom closure which has not been shown. The upper end of body 11 (FIG. 2) is then necked-in to produce outwardly formed end seam flanges 26. The next step in container manufacture is a folding operation wherein inner ply 32 of integral elongated flap 15 is hinged about vertical score line 34 withdrawing tear tab 44 from filling and dispensing opening 47 in preparation for attaching inner ply 31 to end seam flanges 26 (FIG. 3). From this position inner ply 31 may be hinged about score line 29 until the under surface of inner ply 31 contacts end seam flanges 26 when the two may be adhesively attached at all points of contact. During this operation tear tab 44 lies in close relation to side wall panel 22 and outer ply 32 stands vertically (FIGS. 3 and 4).

The container as seen in FIGURE 4 is now ready for filling through opening 47.

To close the container after filling, outer ply 32 is hinged about score line 34 until contact is made between inner ply 31 and outer ply 32 when the two may be adhesively attached at all points of contact. In this operation (FIGS. 4 and 7) a small area of tear strip 51 will be in contact with a part of end seam flange 26 exposed

by the cutting out of protecting members 45 and 46 from inner ply 31 and it is preferred that adhesion over this small area shall be light for later rupture of the bond at this point to dispense the contents of the container (FIG. 7). The filled container is completed by forming protecting members 45 and 46 and the intervening portion of tear tab 44 under end seam flange 26 to have the appearance of FIGURE 1.

To dispense the contents of the container tear tab 44 is grasped with thumb and forefinger and drawn upwardly and over the top of the container to first rupture the bond between end seam flange 26 and tear tab 44 and then to sever tear strip 51 along weakened scores 48 and 50 to uncover dispensing opening 47 (FIG. 7).

To reclose the container tear strip 51 is hinged back to its original position and tear tab 44 with protecting members 45 and 46 is hooked under end seam flange 26 (FIG. 7).

FIGURE 8 of the drawings discloses a modified blank 52 similar to blank 13 (FIG. 5) except that provision is made for a small section 53 of end seam flange 26 to be held to the remainder of the flange by weakened score lines 54, 55, and 56. As can be seen from FIGURE 9 section 53 is so located that it is adhesively held between tear strip 51 and tear tab 44 with protecting members 45 and 46 and may be carried from its position in end seam flange 26 when tear tab 44 is raised to open the container.

It is to be understood that in the foregoing operations a suitable adhesive will be used in all joints where required or the waterproof coating of the container may in some cases serve as the adhesive.

It is thought that the invention and most of its advantages will be understood from the foregoing description and it will be apparent that changes may be made in the construction and arrangement of the parts without departing from the spirit and scope of the invention, the form hereinbefore described being a preferred embodiment thereof.

I claim:

1. A container for liquids comprising a tubular body of foldable material closed at its lower end, three side walls of said body terminating at their upper edges in a necked-in area and outwardly extending end seam flanges, the fourth wall of said body terminating in a necked-in area and an outwardly extending end seam flange and integral therewith a two ply dispensing top closure including an inner ply having a filling and dispensing opening therein and an outer ply having a tear strip therein, said outer ply integrally hinged to said first ply, said tear strip having an integral tear tab formed of material cut from said filling and dispensing opening in said inner ply.

2. A closure for a rectangular tubular container including an outer ply and an inner ply, said outer and inner plies made from a single piece of material, said outer ply having a tear strip severable along weakened scores, and integral with said tear strip a tear tab formed from material cut out of said inner ply to form a filling and dispensing opening.

3. A container closed at its upper end by a closure as claimed in claim 2.

4. A flat blank of foldable material including a major

area substantially rectangular in configuration scored vertically by four lines separating said major area into five wall panel areas and scored horizontally near the upper edge setting off a narrow end seam flange forming area, surmounting one of said wall panel areas and integral with one of said flange forming areas an elongated flap divided by a vertical score line into two parts of substantially equal area, one of said two parts designed to form an inner ply and the other designed to form an outer ply of a two-ply top closure when in folded condition, said two parts having therein weakened score lines defining a tear strip in one part leading from a tear tab cut from the other part while forming a dispensing opening in said other part.

5. A container formed by folding and gluing the blank claimed in claim 4.

6. A flat blank as claimed in claim 4 wherein a tear tab and protecting members for a pouring surface are cut from one part of an integral elongated flap and lead to a tear strip defined by weakened score lines in said other part of said integral elongated flap.

7. A container formed by folding and gluing the blank claimed in claim 6.

8. A container closure comprising a single elongated flap integral with a container body, said flap folded upon itself at substantially a median position providing a two-ply dispensing top closure in which an integral tear tab is formed at an edge of one ply from material severed from another ply while producing a filling and dispensing opening in said other ply.

9. A container closed at its upper end by a closure as claimed in claim 8.

10. A flat blank as claimed in claim 4 wherein an area outlined by weakened scores is located in an end seam flange forming area adjacent the upper edge and is designed to tear out of said end seam flange forming area upon manipulation of said tear tab when said blank is in folded condition.

11. A container formed by folding and gluing the blank claimed in claim 10.

12. A flat blank as claimed in claim 6 wherein an area outlined by weakened scores is located in an end seam flange forming area adjacent the upper edge and is designed to tear out of said end seam flange forming area upon manipulation of said tear tab when said blank is in folded condition.

13. A container formed by folding and gluing the blank claimed in claim 12.

14. The container claimed in claim 1 wherein the lower end of said container is closed by an integral flap or a number of integral flaps.

15. The blank claimed in claim 4 wherein material at the lower end of said blank takes the form of an integral flap or multiplicity of flaps adapted for closing the lower end of a container when said blank is in folded condition.

16. A container formed by folding and gluing the blank of claim 15.

#### References Cited in the file of this patent

#### UNITED STATES PATENTS

2,884,178 Hovland ----- Apr. 28, 1959  
3,047,200 Hill ----- July 31, 1962