

March 31, 1953

W. S. DE MASTERS

2,632,958

DEVICE FOR DETERMINING GRADE SLOPES

Filed Dec. 8, 1950

FIG. 1.

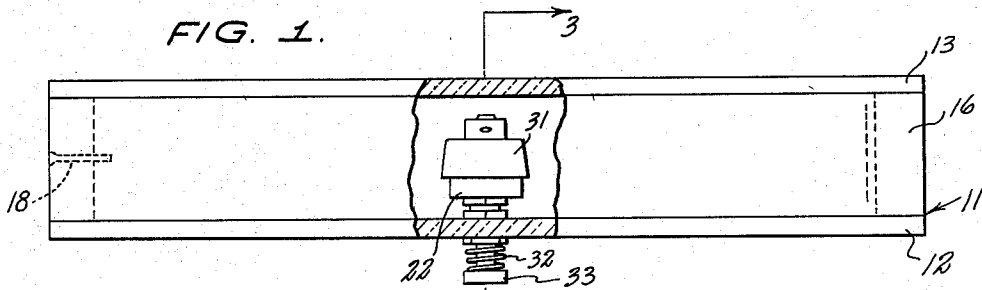

FIG. 2.

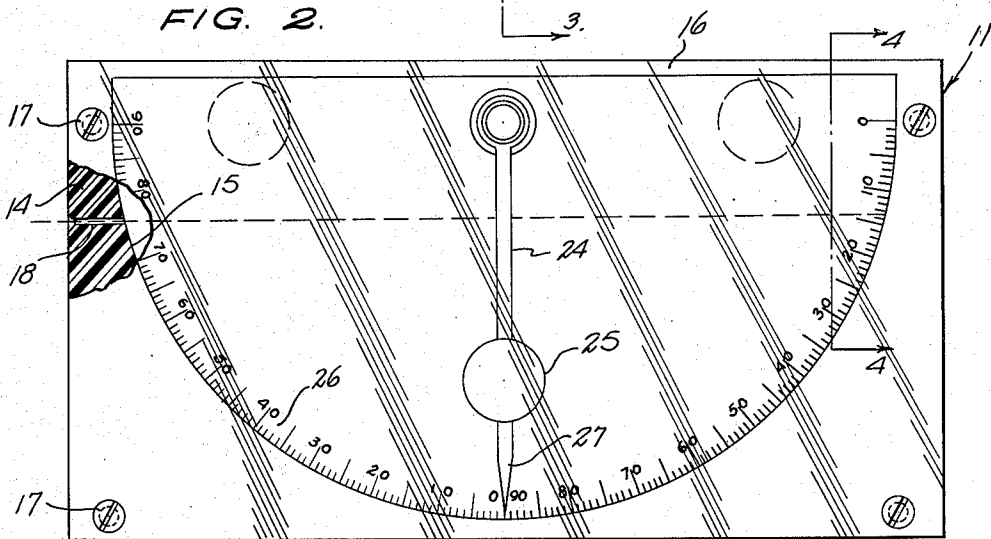

FIG. 3.

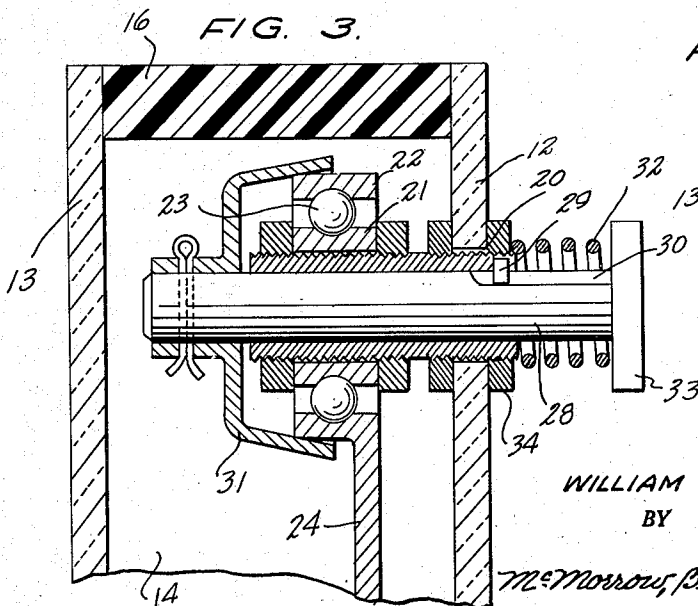
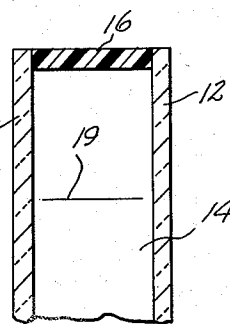

FIG. 4.



INVENTOR.  
WILLIAM S. DE MASTERS,  
BY

Mc Morrow, Bertram + Davidson  
ATTORNEYS.

# UNITED STATES PATENT OFFICE

2,632,958

## DEVICE FOR DETERMINING GRADE SLOPES

William S. De Masters, Kansas City, Mo.

Application December 8, 1950, Serial No. 199,881

2 Claims. (Cl. 33-215)

1

This invention relates to levels, and more particularly to a hand level of the gravity operated type.

A main object of the invention is to provide a novel and improved hand level for checking grade slopes, for setting stakes, for terracing, and for similar purposes, said device being very simple in construction, being easy to use and providing accurate readings.

A further object of the invention is to provide an improved hand level of the gravity-operated type which is inexpensive to manufacture, which is sturdy in construction, which provides clearly visible readings, and which is valuable for checking grade slopes and fills, for estimating the depths of cuts, and for setting stakes for terracing.

Further objects and advantages of the invention will become apparent from the following description and claims, and from the accompanying drawings, wherein:

Figure 1 is a top plan view, partly in cross section, of an improved hand level device constructed in accordance with the present invention.

Figure 2 is a side elevational view, partly in cross section, of the hand level device of Figure 1.

Figure 3 is an enlarged fragmentary cross sectional detail view taken on line 3-3 of Figure 1.

Figure 4 is a fragmentary cross sectional view taken on the line 4-4 of Figure 2.

Referring to the drawings, the hand level device is designated generally at 11 and may comprise a pair of transparent side walls 12 and 13 of glass, plastic or similar transparent material secured to an intervening transparent glass or plastic block 14 which is formed with a semi-circular recess 15, to define a semi-circular cavity between the walls 12 and 13. Secured to the top ends of the block 14 between the upper longitudinal margins of the side walls 12 and 13 is a plastic cover 16 which closes the cavity defined by the block 14 and the side walls 12 and 13. The side walls 12 and 13 may be secured to the block 14 by transverse bolts such as are shown at 17.

As shown in Figure 2, the left end portion of the block 14 is formed with an aperture 18 extending parallel to the top cover member 16. The right end wall of the block 14 is provided with a transverse hair line 19 which is in alignment with the aperture 18, the plane defined by the line 19 and the aperture 18 being parallel to the top cover 16.

Secured to the side wall 12 on an axis which is

2

centered with respect to the semi-circular recess 15 is a sleeve member 20 which extends transversely into the cavity above described. Secured to the inner end portion of the sleeve 20 in the inner race 21 of a ball bearing unit, the outer race of said unit being designated at 22 and being rotatably supported on the inner race 21 by the ball bearings 23. Integral with the outer race 22 is a depending pointer 24 which is provided adjacent its free ends with a weight 25 which biases the pointer 24 to a vertical position. The transparent side walls 12 and 13 are inscribed with angle scales 26 which extend along a semi-circular arc concentric with the sleeve 20 and which are arranged adjacent to the pointed end 27 of the pointer 24.

Designated at 28 is a shaft slidably positioned in the sleeve 20, said shaft being non-rotatably held in the sleeve by an inwardly projecting pin element 29 carried by the sleeve 20 which slidably engages in a longitudinal keyway 30 formed in the shaft 28. Secured to the inner end of the shaft 28 is a cup shaped member 31 which is engageable with the periphery of the outer race 22 of the bearing unit, as shown in Figure 3, to hold the outer race 22 against rotation with respect to the sleeve 20. Secured to the outer end of shaft 28 is an enlarged head member 33 and designated at 32 is a coil spring which surrounds the shaft 28 and which bears at one end on the head 33 and at the other end on one of the clamping nuts 34 employed for securing the sleeve 20 to the side wall 12. The spring 32 biases the shaft 28 to the right, as viewed in Figure 3, urging the cup 31 into frictional binding engagement with the outer race 22 of the bearing unit, normally locking the pointer 24 against rotation. When the head member 33 is pressed inwardly, the outer race 22 is released and the pointer 24 is free to swing by gravity to a vertical position.

In using the device, the operator sights along the aperture 18 and the hair line 19 to bring the object whose slope is to be determined into registry with the hair line 19 and at the same time presses the head member 33 inwardly to release the weighted pointer 24. After the object has been thus sighted, the operator releases his pressure on the head member 33, allowing the cup member 31 to frictionally engage the outer bearing race 22, to thereby lock the weighted pointer 24 in the position which was assumed by it during the sighting operation. The operator then observes the position of the tapered end 27 of pointer 24 relative to the angle scale 26 and reads the slope angle directly therefrom.

3

While a specific embodiment of an improved slope indicating device has been disclosed in the foregoing description, it will be understood that various modifications within the spirit of the invention may occur to those skilled in the art. Therefore, it is intended that no limitations be placed on the invention except as defined by the scope of the appended claims.

What is claimed is:

1. A slope indicator comprising a housing having a transparent side wall, one transparent end wall, and an aperture in its opposite end wall, a transverse sleeve secured to said side wall on an axis parallel to the plane of said aperture, a pointer pivoted on said sleeve for swinging movement parallel to said side wall, said pointer having an annular hub element rigid therewith, an arcuate scale on said side wall adjacent the free end of said pointer, a shaft slidably and non-rotatably positioned in said sleeve and extending outside the housing, a cup member on the end of said shaft within said housing and frictionally engageable with said hub element, and hand actuable means on the end of said shaft outside said housing.

2. A slope indicator comprising a housing having a transparent side wall, one transparent end wall, and an aperture in its opposite end wall, a transverse hair line on said transparent end wall, a transverse sleeve secured to said side wall on

4

an axis parallel to the plane of said aperture and hair line, a pointer pivoted on said sleeve for swinging movement parallel to said side wall, an arcuate scale on said side wall adjacent the free end of the pointer, a shaft slidably and non-rotatably positioned in said sleeve and extending outside the housing, a cup member on the inner end of said shaft frictionally engageable with said pointer, an enlarged head on the outer end of said shaft, and a coil spring surrounding said shaft and bearing between said head and said side wall and biasing the shaft outwardly, whereby the cup member normally locks the pointer against rotation.

WILLIAM S. DE MASTERS.

#### REFERENCES CITED

The following references are of record in the file of this patent:

#### UNITED STATES PATENTS

Number	Name	Date
279,443	Sands	June 12, 1883
396,883	Lawrence	Jan. 29, 1889
449,557	Mounts	Mar. 31, 1891
920,718	Bernard	May 4, 1909
1,209,395	Church	Dec. 19, 1916
1,227,360	Young	May 22, 1917
2,022,452	Aegerter	Mar. 26, 1935
2,383,527	Whitechester	Aug. 28, 1945