

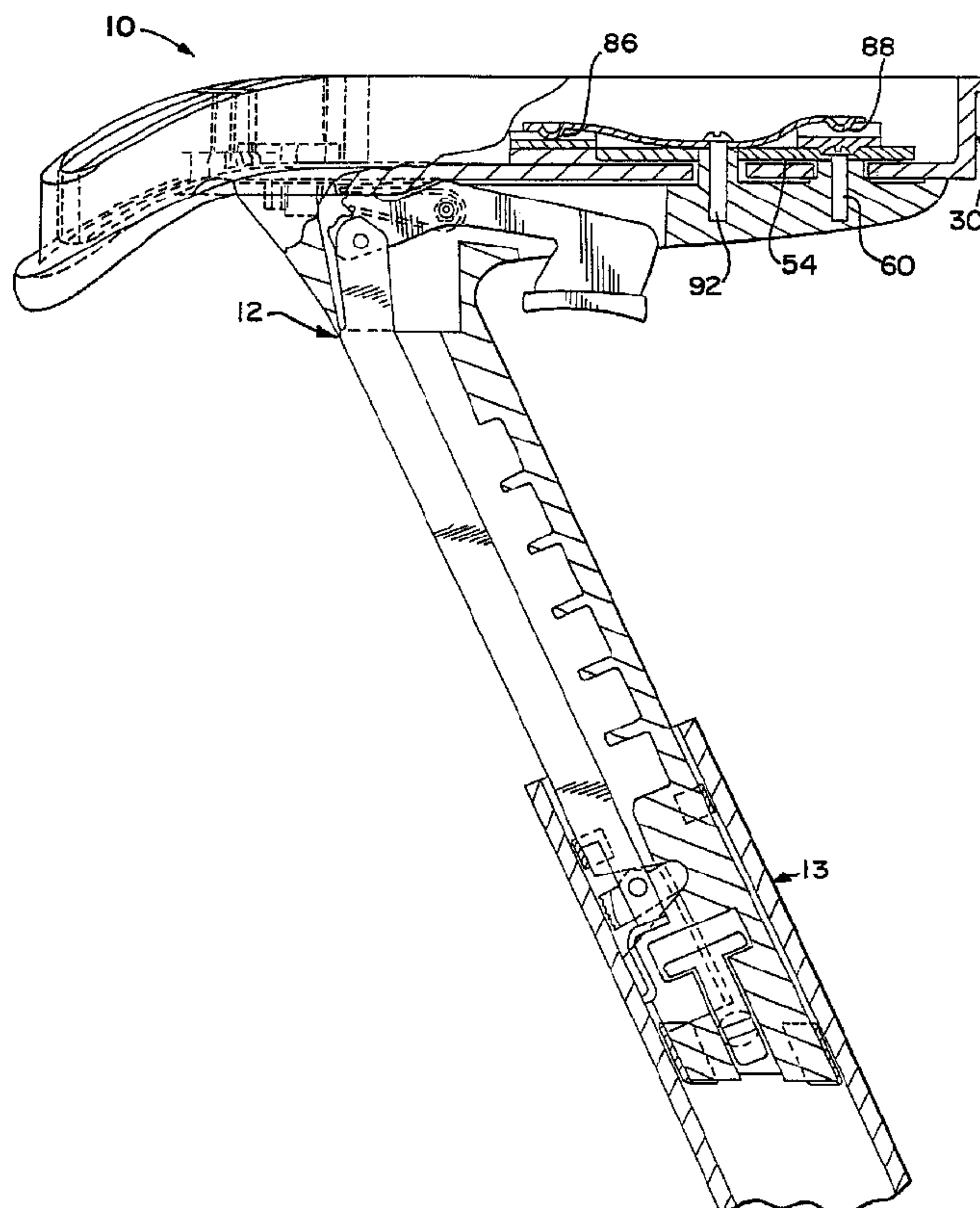

(86) Date de dépôt PCT/PCT Filing Date: 1996/06/03
 (87) Date publication PCT/PCT Publication Date: 1996/12/19
 (45) Date de délivrance/Issue Date: 2001/08/21
 (85) Entrée phase nationale/National Entry: 1997/12/03
 (86) N° demande PCT/PCT Application No.: US 96/08414
 (87) N° publication PCT/PCT Publication No.: WO 96/39901
 (30) Priorité/Priority: 1995/06/07 (08/482,175) US

(51) Cl.Int.⁶/Int.Cl.⁶ A47C 7/54
 (72) Inventeurs/Inventors:
 WEBER, Jeffrey A., US;
 VAN DE RIET, Douglas M., US
 (73) Propriétaire/Owner:
 HERMAN MILLER, INC., US
 (74) Agent: CASSAN MACLEAN

(54) Titre : ENSEMBLE ACCOUDOIR REGLABLE
 (54) Title: ADJUSTABLE ARM REST ASSEMBLY



(57) Abrégé/Abstract:

An adjustable arm rest assembly (31) for use on a chair including an arm rest post (12) and an arm rest support surface (31). According to one aspect of the invention, the support surface (31) is pivotally attached to a top surface (14) of the arm rest post. The support surface includes a front portion and a rear portion and is pivotable about a pivot axis that extends in parallel with the seat back of the chair. A locking element (80) is attached to one of the arm rest post and the support surface. The locking element includes a front portion (82) and a rear portion (84) with the front portion including a first mating element (86). The front

(57) Abrégé(suite)/Abstract(continued):

portions of the support surface and locking element are farther from the seat back than the rear portions. A guide member (76) is attached to the other of the arm rest post and the support surface. The guide member (76) is located adjacent the front portion of the locking element and is adapted to receive the first mating element (86) into one of a plurality of second mating elements (78). The locking element (80) and the guide member (76) are movable with respect to one another so that the support surface may be secured in a selected position relative to the arm rest post.

PCT

WORLD INTELLECTUAL PROPERTY ORGANIZATION
International Bureau

INTERNATIONAL APPLICATION PUBLISHED UNDER THE PATENT COOPERATION TREATY (PCT)

<p>(51) International Patent Classification ⁶ : A47C 7/54</p>	<p>A1</p>	<p>(11) International Publication Number: WO 96/39901</p> <p>(43) International Publication Date: 19 December 1996 (19.12.96)</p>
<p>(21) International Application Number: PCT/US96/08414</p> <p>(22) International Filing Date: 3 June 1996 (03.06.96)</p> <p>(30) Priority Data: 08/482,175 7 June 1995 (07.06.95) US</p> <p>(71) Applicant: HERMAN MILLER, INC. [US/US]; 855 East Main Avenue, Zeeland, MI 49464-0302 (US).</p> <p>(72) Inventors: VAN DE RIET, Douglas, M.; 2198 North Bristol, Holland, MI 49424 (US). WEBER, Jeffrey, A.; 2614 Vincent Avenue North, Minneapolis, MN 55411 (US).</p> <p>(74) Agent: PRENDERGAST, William, F.; Brinks, Hofer, Gilson & Lione, NBC Tower, Suite 3600, 455 North Cityfront Plaza Drive, Chicago, IL 60611-5599 (US).</p>		<p>(81) Designated States: AL, AM, AT, AU, AZ, BB, BG, BR, BY, CA, CH, CN, CZ, DE, DK, EE, ES, FI, GB, GE, HU, IL, IS, JP, KE, KG, KP, KR, KZ, LK, LR, LS, LT, LU, LV, MD, MG, MK, MN, MW, MX, NO, NZ, PL, PT, RO, RU, SD, SE, SG, SI, SK, TJ, TM, TR, TT, UA, UG, UZ, VN, ARIPO patent (KE, LS, MW, SD, SZ, UG), Eurasian patent (AM, AZ, BY, KG, KZ, MD, RU, TJ, TM), European patent (AT, BE, CH, DE, DK, ES, FI, FR, GB, GR, IE, IT, LU, MC, NL, PT, SE), OAPI patent (BF, BJ, CF, CG, CI, CM, GA, GN, ML, MR, NE, SN, TD, TG).</p> <p>Published <i>With international search report.</i></p>

(54) Title: ADJUSTABLE ARM REST ASSEMBLY

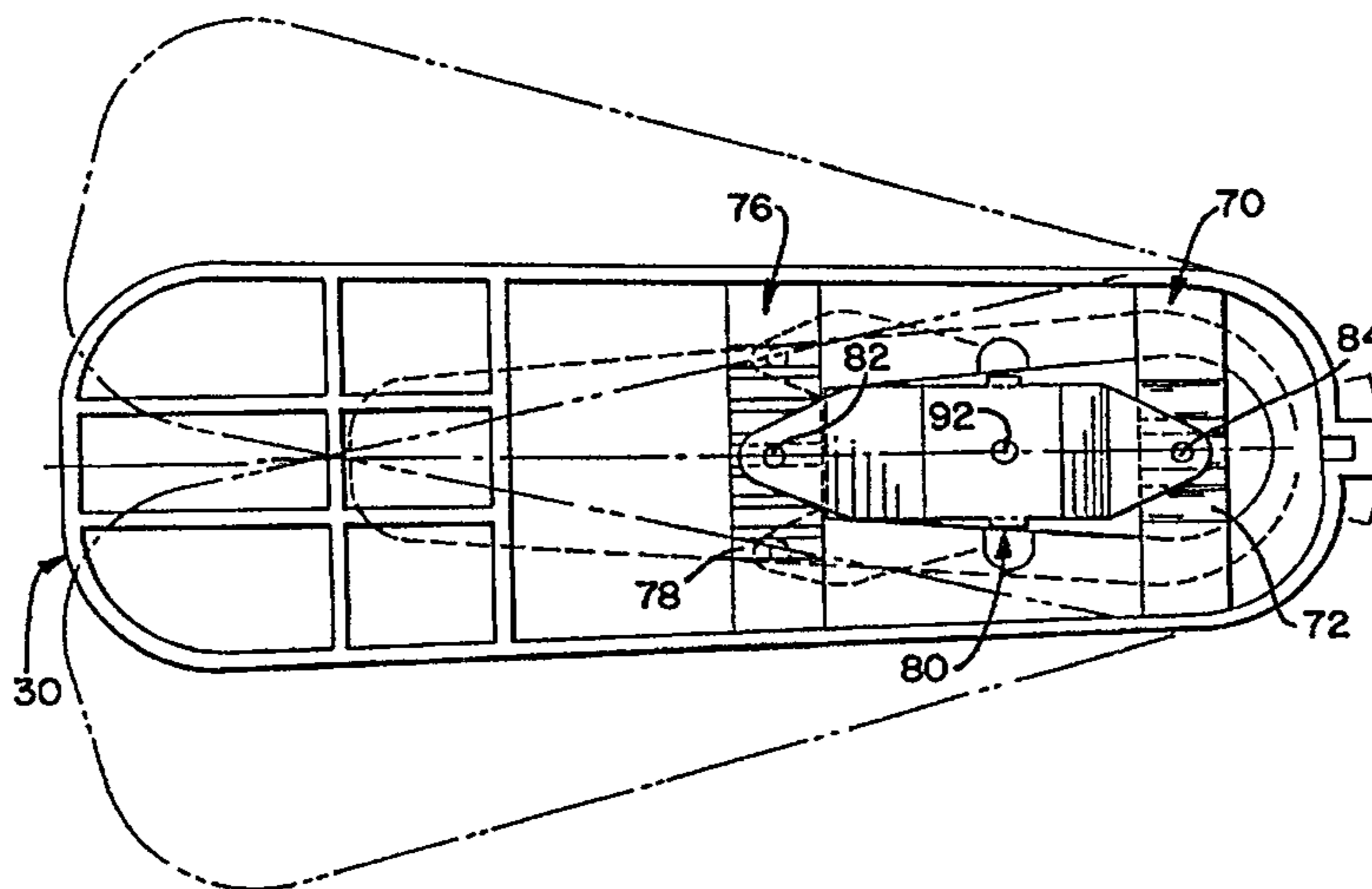

(57) Abstract

An adjustable arm rest assembly (31) for use on a chair including an arm rest post (12) and an arm rest support surface (31). According to one aspect of the invention, the support surface (31) is pivotably attached to a top surface (14) of the arm rest post. The support surface includes a front portion and a rear portion and is pivotable about a pivot axis that extends in parallel with the seat back of the chair. A locking element (80) is attached to one of the arm rest post and the support surface. The locking element includes a front portion (82) and a rear portion (84) with the front portion including a first mating element (86). The front portions of the support surface and locking element are farther from the seat back than the rear portions. A guide member (76) is attached to the other of the arm rest post and the support surface. The guide member (76) is located adjacent the front portion of the locking element and is adapted to receive the first mating element (86) into one of a plurality of second mating elements (78). The locking element (80) and the guide member (76) are movable with respect to one another so that the support surface may be secured in a selected position relative to the arm rest post.

ADJUSTABLE ARM REST ASSEMBLY

BACKGROUND OF THE INVENTION

The present invention relates to the field of arm rests for use on chairs. More particularly, the invention relates to the field of arm rests which are adjustable to various positions to provide a more comfortable chair for a user.

5 Chairs, particularly office chairs, are often designed with the arm rests secured in a fixed position based on the intended use of the chair and the average size of the expected users. However, in an office environment, people of different sizes may spend many hours in the same size chair. Therefore, it is desirable to have arm rests that are adjustable to match the specific anatomy of a given user. A chair, in particular the
10 arm rests, should be comfortable for people of all sizes and shapes. For example, a user having a small body size may desire arm rests that are somewhat closer than those found on a standard size chair. Similarly, a user having a large body size may desire arm rests that are moved outward somewhat from the standard position.

15 Arm rests should also be angularly adjustable depending on the varied activities of the user of the chair. A user may desire the arm rests in a first angular position when typing or working with a pen and paper on a desk. The user, however, may desire a second angular position when working with a mouse for a computer.

 While adjustable arm rests have been previously disclosed, there still exists a need for adjustable arm rests that provide reliable operation.

20 SUMMARY OF THE INVENTION

 Briefly stated, the present invention is directed to an adjustable arm rest assembly for use on a chair including an arm rest post and an arm rest support surface, the support surface being movably attached to the arm rest post. According to one aspect of the invention, the support surface includes a front portion and a rear portion and is
25 pivotal about a pivot axis that extends in parallel with the seat back of the chair. A locking element is attached to one of the arm rest post and the support surface. The locking element includes a front portion and a rear portion with the front portion including a first mating element. The front portions of the support surface and locking

- 2 -

5 element are farther from the seat back than the rear portions. A guide member is attached to the other of the arm rest post and the support surface. The guide member is located adjacent the front portion of the locking element and includes a row of second mating elements that are adapted to receive the first mating element. The locking element and the guide member are movable with respect to one another so that the support surface may be secured in a selected position relative to the arm rest post.

10 According to another aspect of the invention, an arm rest housing and support surface are laterally adjustable with respect to the arm rest post. According to this aspect, a second guide member having a second row of mating elements is located adjacent the rear portion of the locking element. The arm rest post has a boss extending from a top surface that is received within a slot in the lower surface of the arm rest housing. The slot is sized so as to allow only a lateral movement.

15 According to a further aspect of the invention, the locking element is attached to the arm rest post and the guide members are attached to the arm rest housing.

20 According to yet a further aspect of the invention, the locking element is a ~~detent and the guide members~~ are formed by a series of projecting surfaces.

As used herein, the term "arm rest post" is intended to include both male and female elements, e.g., a stem or a sleeve.

25 The present invention will be best understood with reference to the detailed description below read in conjunction with the accompanying drawings.

BRIEF DESCRIPTION OF THE DRAWINGS

FIGURE 1 is a side view in partial cross-section of a preferred embodiment of the adjustable arm rest assembly of the present invention;

25 FIGURE 2 is an exploded view of a preferred embodiment of the present invention;

FIGURE 3 is a top view of a preferred embodiment of the present invention showing in shadow two different angular positions for the arm rest housing; and

FIGURE 4 is a top view of a preferred embodiment of the present invention showing in shadow a different lateral position for the arm rest housing.

- 3 -

DETAILED DESCRIPTION OF THE PREFERRED EMBODIMENTS

Referring to the drawings, Fig. 1 shows an adjustable arm rest assembly 10 for use on a chair having a seat and a seat back. The assembly 10 includes an arm rest post 12, preferably formed from 30% glass-filled nylon, that is slidably received by a support member 13, preferably formed from aluminum. The support member 13 is attached to a chair beneath the seat thereof. As best seen in Fig. 2, the arm rest post 12 has a top surface 14. The top surface 14 includes a first boss 16 and a second boss 18. The first boss 16 has a circular shape and the second boss 18 has a diamond shape.

For a description of the height adjustment assembly including the arm rest post 12 and the support member 13, reference is made to the commonly assigned application filed on June 7, 1995, in the name of Douglas M. Van De Riet, and entitled HEIGHT ADJUSTABLE ARM REST.

A housing 30 is movably mounted to the top surface 14 of the arm rest post 12. The housing 30 is somewhat wider and longer than the top surface 14. An arm pad 31 is attached to the housing 30 and includes an arm support surface 32. The arm pad 31 engages the outer wall 33 of the housing 30 up to the flange 34. The arm pad 31 may be made from materials known to those of ordinary skill in the art. The housing 30 also has a lower surface 36 and a front portion 38. A first slot 40 and a second slot 42 extend in the lower surface 36 of the housing 30. In this embodiment, the first slot 40 has a slightly shorter length than the second slot 42. The first slot 40 receives the first boss 16 and the second slot 42 receives the second boss 18. According to a preferred embodiment, the slots 40 and 42 are sized so that their respective bosses 16 and 18 are freely movable therein in order to allow the housing 30 to be moved both laterally and angularly with respect to the arm rest post 12. According to another preferred embodiment, the slots 40 and 42 are sized so as to restrict the angular movement of the housing 30. More specifically, the slots 40 and 42 would have a width substantially equal to the width of the bosses 16 and 18. As a result, the housing 30 would only be moved in a lateral direction toward or away from a user. The housing 30 is preferably manufactured using an injection molding process with 13% glass-filled polypropylene.

The housing 30 has an internal cavity 50 that is defined in part by the outer wall 33 and the lower surface 36. A cold rolled steel plate 54 is mounted within the

- 4 -

5 cavity 50. The plate 54 has a first aperture 56 and a second aperture 58 therein. The distance between the first aperture 56 and the second aperture 58 is approximately equal to the distance between the first slot 40 and the second slot 42. A fastening mechanism such as the screw 60 passes through the second aperture 58, the second slot 42 and into the second boss 18.

10 A rear guide member 70, preferably formed from case-hardened cold rolled steel, is also received within the cavity 50 and secured to the housing 30 in the channels 71. The rear guide member 70 is attached to the housing 30 above the second slot 42 and includes a plurality of rear mating elements 72. The mating elements 72 take the form of a plurality of projecting surfaces that form curved channels that extend lengthwise within the cavity 50 or in a direction perpendicular to a corresponding seat back. In this embodiment, three channels comprise the mating elements 72.

15 A front guide member 76 is formed integral with the housing 30 slightly behind the first slot 40. As with the rear guide member 70, the front guide member 76 has a row of mating elements 78 extending therein. The front mating elements 78 also take the form of a plurality of projecting surfaces that form curved channels that extend lengthwise within the cavity 50 or in a direction perpendicular to a corresponding seat back. In contrast to the rear guide member 70, the front guide member 76 has seven channels. Rather than having uniformly curved channels or projecting surfaces, in 20 another preferred embodiment the mating elements 72 and 78 are modified to have a steeper angle of inclination at the outer edges of the guide members 70 and 76. In this manner, it would require more force for a user to adjust the housing 30 when closer to the ends of the guide members 70 and 76.

25 A wear strip 79 is attached to the top surface of the front guide member 76 over the mating elements 78 and is configured to conform with the front guide member 76. The wear strip 79 is formed from case-hardened cold rolled steel and functions to protect the front mating elements 78 of the guide member 76 from being worn down.

30 A locking element or detent spring 80 is positioned within the cavity 50 between the front and rear guide members 70 and 76. The detent 80, preferably formed from spring steel, has front and rear portions 82 and 84 that extend over the front and rear guide members 70 and 76, respectively. The front portion 82 is farther from the seat back of the chair than the rear portion 84. As best seen in Fig. 1, the front and rear

- 5 -

portions 82 and 84 have male mating elements that comprise downwardly extending front and rear projecting surfaces 86 and 88. The projecting surfaces 86 and 88 are biased into engagement with the front mating elements 78 and rear mating elements 72, respectively. The detent 80 is configured so as to more strongly bias the rear projecting surface 88 into engagement with the rear mating elements 72 than it biases the front projecting surface 86 into engagement with the front mating elements 76. An aperture 90 is centrally located within the detent 80 and is positioned above the first aperture 56 within the plate 54. A fastening mechanism 92, such as a screw, passes through the aperture 90 of the detent 80 and through the first aperture of plate 54 and the first slot 40 into the boss 16 in the arm rest post 12.

It should be recognized that the specific interconnection of elements could be easily modified by those of ordinary skill in the art so as to still practice the present invention. For example, the preferred embodiment shown in the Figures could be modified so as to change the relative interconnection of the locking element and the guide members with respect to the arm rest post and arm rest housing. More specifically, the guide members could be connected to the arm rest post and the locking element could be connected to arm rest housing. Accordingly, it should be recognized that the preferred embodiment of the Applicants' invention shown in the Figures could be modified in a wide variety of ways.

In the preferred embodiment shown in Fig. 3, the arm rest housing 30 and attached pad 31 are angularly adjustable with respect to the arm rest post 12 (as shown in shadow). In order to accomplish this adjustment, a user would apply a lateral force to the housing 30 approximately adjacent the front guide member 76. As a result, the front projecting surface 86 is moved from engagement with a first projecting surface of the mating elements 78 to a second projecting surface of the mating elements 78. More specifically, the user overcomes the downward force applied by the front portion 82 of the detent 80. The housing 30 then pivots in the direction of the applied force with the first and second slots 40 and 42 moving with respect to the first and second bosses 16 and 18. During this angular positioning, the rear projecting surface 88 remains fixed within the previously selected channel of the rear mating elements 72. Accordingly, the rear projecting surface 88 forms a pivot member that defines a pivot axis about which the housing 30 rotates.

- 6 -

As shown in Fig. 4, the arm rest housing 30 and the attached pad are also movable laterally with respect to the arm rest post 12 (as shown in shadow) or toward and away from the user of a chair. In order to accomplish this adjustment, a user would apply a lateral force to the housing 30. However, in contrast with the force applied to move the housing 30 to a new angular position, the force applied by the user should be in between the front and rear guide members 76 and 70. A force applied in this manner moves the front projecting surface 86 from engagement with a first projecting surface of the front mating elements 78 to a second projecting surface of the front mating elements 78. In addition, the rear projecting surface 88 is also moved from engagement with a first projecting surface of the rear mating elements 72 to a second projecting surface of the rear mating elements 72. More specifically, the user overcomes the downward force applied by the front and rear portions 82 and 84 of the detent 80. Accordingly, the housing 30 moves laterally in the direction of the applied force with the first and second slots 40 and 42 again moving with respect to the first and second bosses 16 and 18.

The embodiment described is illustrative and not restrictive. The scope of the invention is indicated by the claims rather than by the foregoing description. The invention may be embodied in other specific forms without departing from the spirit of the invention. For example, the number of projecting surfaces within the front and rear guide members may easily be modified without departing from the spirit of this invention. Similarly, the specific materials used or the configurations of the parts may also be easily changed. Accordingly, all changes which come within the scope of the claims are intended to be embraced therein.

I CLAIM:

1. A height adjustable arm rest assembly for use on a chair, said arm rest assembly comprising:
 - a support member;
 - an arm rest member attached to said support member, said support member and said arm rest member extending substantially coaxially, one of said support member and said arm rest member being movable with respect to the other;
 - a locking mechanism attached to one of said support member and said arm rest member in order to secure said arm rest member in a selected vertical position relative to said support member, said locking mechanism comprising:
 - an actuation member;
 - a link connected to said actuation member; and
 - a cam pivotably connected to said link, said cam having a front portion and a rear portion, said rear portion received within a recess of said one of said support member and said arm rest member, said recess sized slightly larger than said rear portion of said cam in order to allow said cam to pivot about a generally horizontal axis through said rear portion of said cam from a first position to a second position within said recess; and
 - a substantially continuous engagement surface on the other of said support member and said arm rest member, said cam positioned adjacent said continuous engagement surface and pivotable into and out of engagement with said continuous engagement surface in response to said actuation member in order to thereby provide said arm rest member with selective height adjustability.
2. The height adjustable arm rest assembly according to claim 1 further comprising a biasing member connected to said locking mechanism in order to bias said cam into engagement with said continuous engagement surface.
3. The height adjustable arm rest assembly according to claim 2 wherein said biasing member comprises a U-shaped spring.
4. The height adjustable arm rest assembly according to claim 3 wherein said link

- 8 -

further includes a resilient foot member that projects downward from beneath said cam and contacts said continuous engagement surface.

5. The height adjustable arm rest assembly according to claim 4 wherein the support member defines an aperture through which said arm rest member partially extends.
6. The height adjustable arm rest assembly according to claim 5 wherein said locking mechanism further includes a laterally extending pin passing through said actuation member and defining a pivot axis.
7. The height adjustable arm rest assembly according to claim 6 wherein said arm rest member has a T-shaped aperture therein that receives a T-shaped stop member having an outwardly projecting raised surface that is received within a channel extending within said support member.
8. The height adjustable arm rest assembly according to claim 7 wherein said cam includes a curved rear portion and plurality of longitudinally extending teeth on said front portion.
9. The height adjustable arm rest assembly according to claim 8 wherein said recess is defined by a curved rear surface.
10. A height adjustable arm rest assembly for use on a chair, said arm rest assembly comprising:
 - a support member having a substantially continuous inner surface that defines a cavity;
 - an arm rest member having a stem extending generally downward therefrom and slidably received within said cavity of said support member;
 - a locking mechanism attached to said arm rest member in order to secure said arm rest member in a selected vertical position relative to said support member, said locking mechanism comprising:
 - an actuation member;

- 9 -

a link connected to said actuation member and extending downward therefrom; and

a cam pivotably connected to a lower portion of said link and positioned adjacent the continuous inner surface of the support member and positioned partially within a recess in said arm rest member, said recess sized slightly larger than a rear portion of said cam in order to allow said cam to pivot about a generally horizontal axis through said rear portion of said cam from a first position to a second position within said recess, said cam having a front surface that is movable into and out of engagement with said continuous inner surface of said support member in response to said actuation member in order to thereby provide the arm rest member with selective height adjustability.

11. The height adjustable arm rest assembly according to claim 10 wherein said support member has a channel extending substantially vertically therein that terminates prior to a top of said support member.
12. The height adjustable arm rest assembly according to claim 11 wherein said arm rest member has a T-shaped aperture therein that receives a T-shaped stop member having an outwardly projecting raised surface that is received within said channel.
13. The height adjustable arm rest assembly according to claim 12 further including a spring received within an aperture in said stem, said spring biasing said raised surface of said stop member into said channel.
14. The height adjustable arm rest assembly according to claim 13 wherein said cam includes a plurality of longitudinally extending teeth.
15. A height adjustable arm rest assembly for use on a chair, said arm rest assembly comprising:
 - p1 a support member having a substantially D-shaped and continuous inner surface that defines a cavity;

an arm rest member having a stem extending generally downward therefrom and slidably received within said cavity of said support member, said arm rest

- 10 -

member including a first recess and a second recess;

a locking mechanism attached to said arm rest member in order to secure said arm rest member in a selected vertical position relative to said support member, said locking mechanism comprising:

an actuation member; a link connected to said actuation member and extending downward therefrom, said link having an upper portion and a lower portion, said lower portion including a pivotable laterally extending lever arm; a cam pivotably connected to said link and positioned directly adjacent said continuous inner surface of said support member, said cam having a front portion and a rear portion, said rear portion received within said first recess, said first recess sized slightly larger than a rear portion of said cam in order to allow said cam to pivot from a first position to a second position within said recess; and

a locking element resting on an end portion of said lever arm of said link, said locking element received within said second recess.

16. The height adjustable arm rest assembly according to claim 15 wherein said second recess is defined by an angled surface that extends upward.
17. The height adjustable arm rest assembly according to claim 16 wherein said locking element is a pin.
18. The height adjustable arm rest assembly according to claim 17 further comprising a biasing member connected to said locking element in order to bias said cam into engagement with said continuous engagement surface.
19. The height adjustable arm rest assembly according to claim 18 wherein said cam has a curved rear portion and a plurality of longitudinally extending teeth on said front portion.
20. The height adjustable arm rest assembly according to claim 19 wherein said first recess is defined by a curved rear surface.

- 11 -

21. A height adjustable arm rest assembly for use on a chair, said assembly comprising:
- a support member having a sleeve that extends upwardly from said chair, the support member further including a substantially continuous engagement surface on an inner surface of the sleeve;
 - an arm rest member including a downwardly extending stem which is slidably received within the sleeve;
 - a locking mechanism attached to one of said support member and said arm rest member, said locking mechanism comprising:
 - an actuation member;
 - a link connected to the actuation member; a generally wedge-shaped recess in the stem which opens toward the engagement surface;
 - a cam received within the recess, said cam including a front, middle and rear portion, said middle portion being connected to said link, said cam being of a size and shape so as to allow the cam to pivot in response to movement of the actuation member, the cam pivotable within the recess about a generally horizontal axis through the rear portion of the cam between a locking position wherein the front portion of the cam engages the engagement surface in the sleeve and a release position wherein the cam disengages the engagement surface, and wherein the cam has a length great enough to prevent the cam from pivoting past the locking position.
22. The height adjustable arm rest assembly of claim 21 wherein said cam pivots downward in order to disengage from the engagement surface.
23. The height adjustable arm rest assembly of claim 22 wherein said recess has a width substantially equal to a width of said cam.
24. The height adjustable arm rest assembly of claim 23 wherein said rear portion of said cam defines a pivot axis about which said cam pivots.
25. The height adjustable arm rest assembly of claim 24 wherein said recess is substantially V-shaped.

- 11(a) -

26. A height adjustable arm rest assembly for use on a chair, said assembly comprising:
- an arm rest member having a sleeve with a substantially continuous engagement surface on an inner surface of the sleeve;
 - a support member for attachment to said chair and extending substantially upward therefrom, said support member including a stem adapted to extend upwardly from said chair;
 - a locking mechanism attached to said support member, said locking mechanism comprising:
 - an actuation member;
 - a link connected to the actuation member;
 - a generally wedge-shaped recess in the stem which opens toward the engagement surface;
 - a cam received within the recess, said cam including a front, middle and rear portion, said middle portion being connected to said link, said cam being of a size and shape so as to allow the cam to pivot in response to movement of the actuation member, the cam pivotable within the recess about a generally horizontal axis through the rear portion of the cam between a locking position wherein the front portion of the cam engages the engagement surface in the sleeve and a release position wherein the cam disengages the engagement surface, and wherein the cam has a length great enough to prevent the cam from pivoting upward past the locking position.
27. The height adjustable arm rest assembly of claim 26 wherein said cam pivots downward in order to disengage from the engagement surface.
28. The height adjustable arm rest assembly of claim 27 wherein said recess has a width substantially equal to a width of said cam.
29. The height adjustable arm rest assembly of claim 28 wherein said rear portion of said cam defines said pivot axis about which said cam pivots.
30. The height adjustable arm rest assembly of claim 28 wherein said recess is substantially V-shaped.

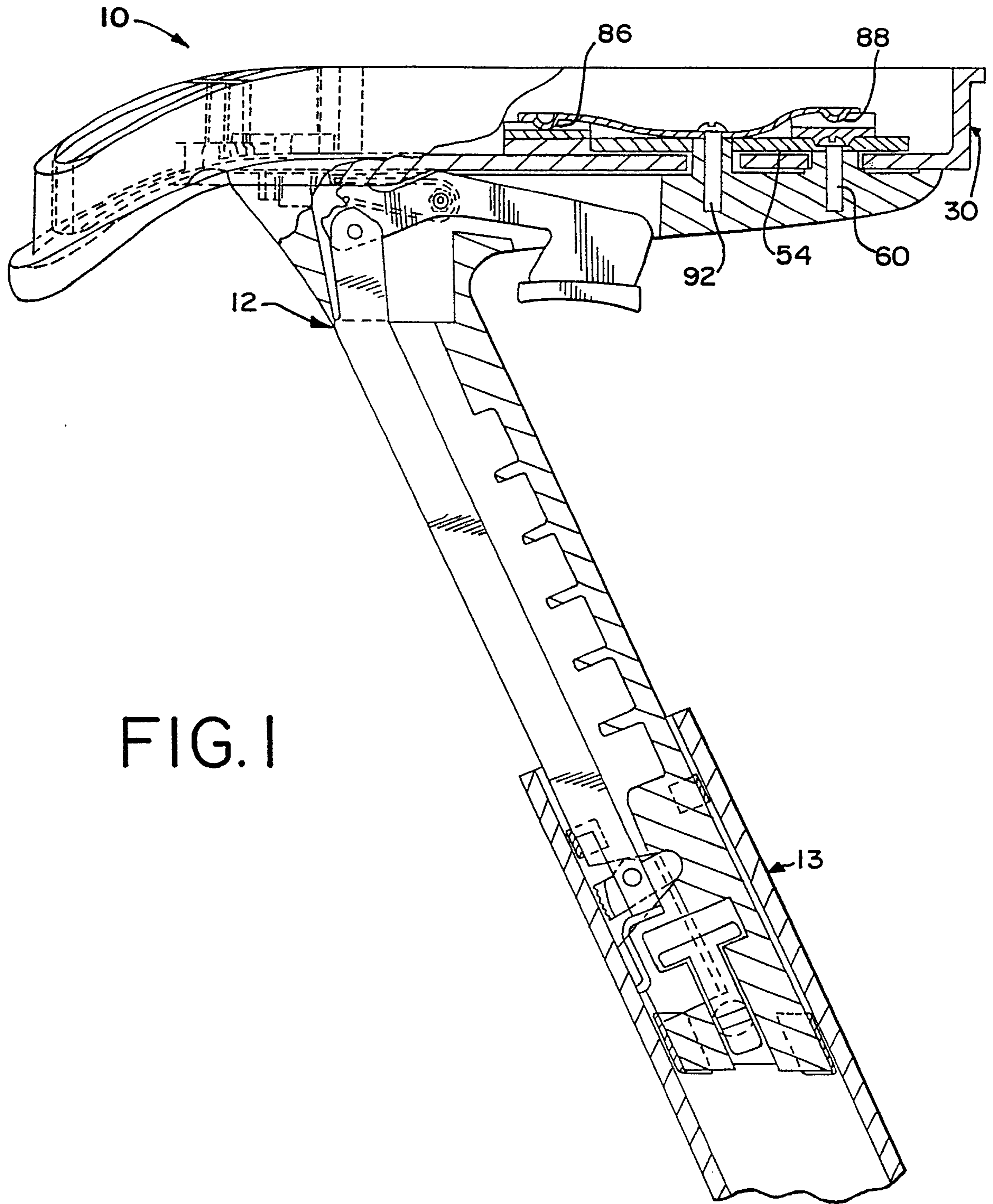

FIG. 1

FIG. 3

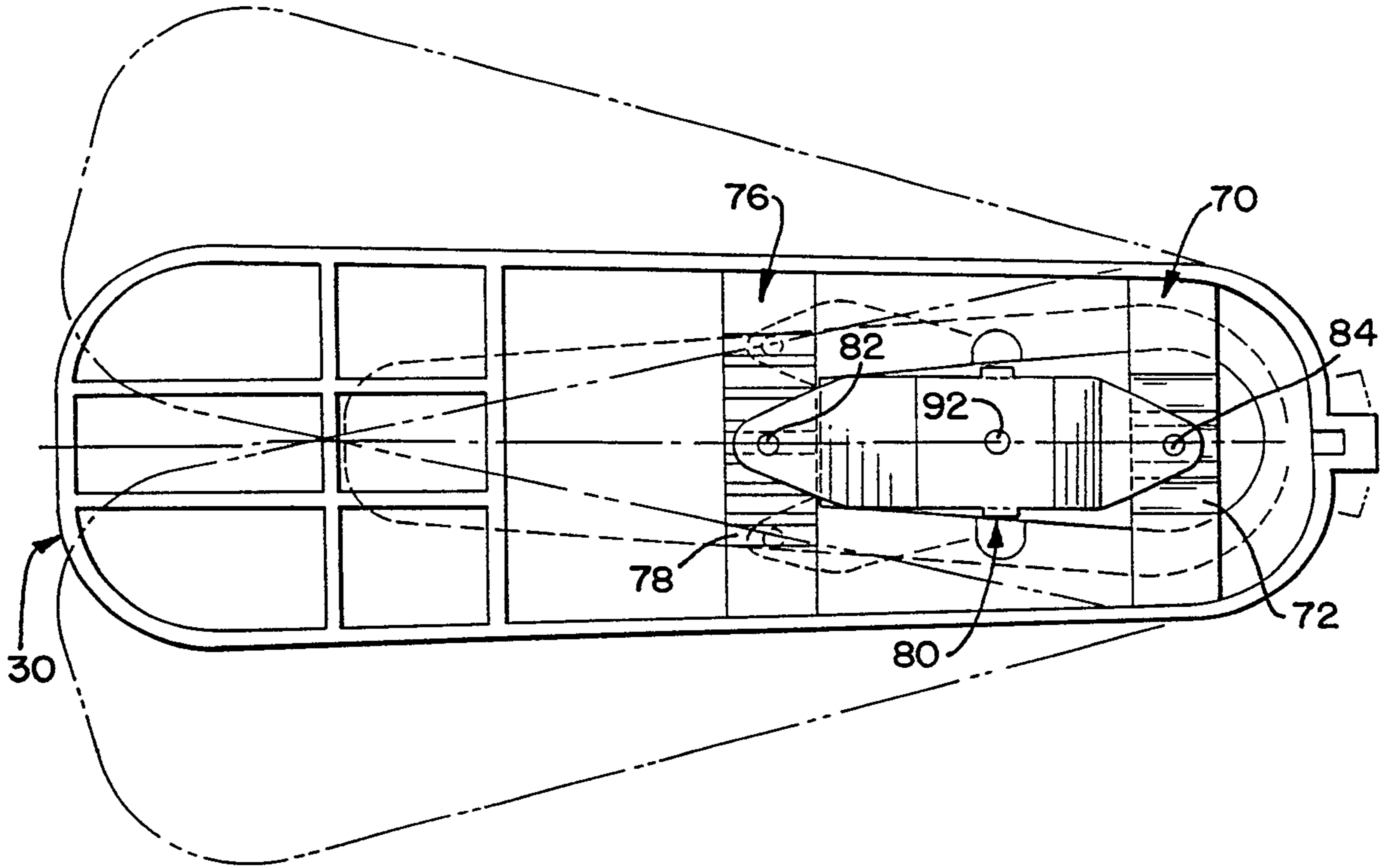

FIG. 4

