

(12) INTERNATIONAL APPLICATION PUBLISHED UNDER THE PATENT COOPERATION TREATY (PCT)

(19) World Intellectual Property  
Organization  
International Bureau



(10) International Publication Number  
**WO 2021/101859 A1**

(43) International Publication Date  
27 May 2021 (27.05.2021)

- (51) **International Patent Classification:**  
*G09G 3/34* (2006.01)      *G02F 1/167* (2006.01)
- (21) **International Application Number:**  
PCT/US2020/060835
- (22) **International Filing Date:**  
17 November 2020 (17.11.2020)
- (25) **Filing Language:** English
- (26) **Publication Language:** English
- (30) **Priority Data:**  
62/936,914      18 November 2019 (18.11.2019) US
- (71) **Applicant: E INK CORPORATION** [US/US]; Attn: IP Department, 1000 Technology Park Drive, Billerica, Massachusetts 01821-4165 (US).
- (72) **Inventors: AMUNDSON, Karl Raymond;** c/o E Ink Corporation, 1000 Technology Park Drive, Billerica, Massachusetts 01821-4165 (US). **SIM, Teck Ping;** c/o E Ink Corporation, 1000 Technology Park Drive, Billerica, Massachusetts 01821-4165 (US).
- (74) **Agent: BAO, Zhen;** c/o E Ink Corporation, 1000 Technology Park Drive, Billerica, Massachusetts 01821-4165 (US).

- (81) **Designated States** (unless otherwise indicated, for every kind of national protection available): AE, AG, AL, AM, AO, AT, AU, AZ, BA, BB, BG, BH, BN, BR, BW, BY, BZ, CA, CH, CL, CN, CO, CR, CU, CZ, DE, DJ, DK, DM, DO, DZ, EC, EE, EG, ES, FI, GB, GD, GE, GH, GM, GT, HN, HR, HU, ID, IL, IN, IR, IS, IT, JO, JP, KE, KG, KH, KN, KP, KR, KW, KZ, LA, LC, LK, LR, LS, LU, LY, MA, MD, ME, MG, MK, MN, MW, MX, MY, MZ, NA, NG, NI, NO, NZ, OM, PA, PE, PG, PH, PL, PT, QA, RO, RS, RU, RW, SA, SC, SD, SE, SG, SK, SL, ST, SV, SY, TH, TJ, TM, TN, TR, TT, TZ, UA, UG, US, UZ, VC, VN, WS, ZA, ZM, ZW.
- (84) **Designated States** (unless otherwise indicated, for every kind of regional protection available): ARIPO (BW, GH, GM, KE, LR, LS, MW, MZ, NA, RW, SD, SL, ST, SZ, TZ, UG, ZM, ZW), Eurasian (AM, AZ, BY, KG, KZ, RU, TJ, TM), European (AL, AT, BE, BG, CH, CY, CZ, DE, DK, EE, ES, FI, FR, GB, GR, HR, HU, IE, IS, IT, LT, LU, LV, MC, MK, MT, NL, NO, PL, PT, RO, RS, SE, SI, SK, SM, TR), OAPI (BF, BJ, CF, CG, CI, CM, GA, GN, GQ, GW, KM, ML, MR, NE, SN, TD, TG).

(54) **Title:** METHODS FOR DRIVING ELECTRO-OPTIC DISPLAYS

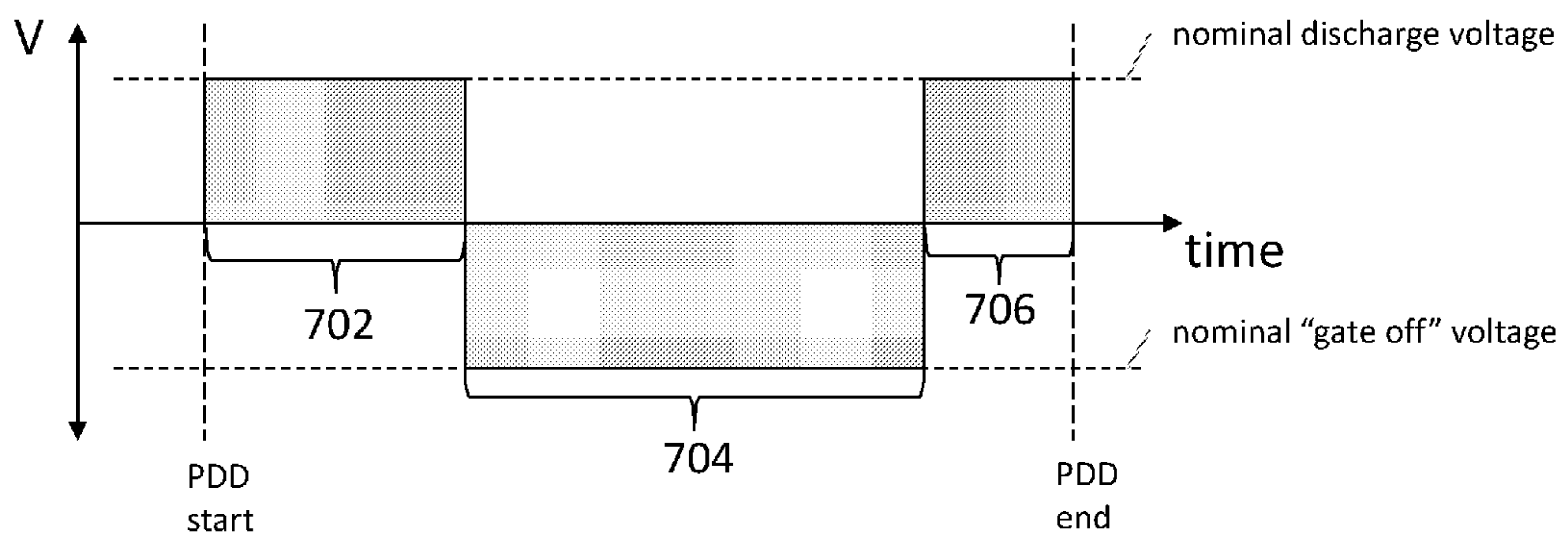

FIG. 7

(57) **Abstract:** Methods for driving an electro-optic display having a plurality of display pixels and each of the plurality of display pixels is associated with a display transistor, the method includes applying a first voltage to a transistor associated with a display pixel for a first duration of time to drain remnant voltages from the display pixel, applying a second voltage to the transistor for a second duration of time to stop the draining of remnant voltages from the display pixel, and applying a third voltage to the transistor for a third duration of time to drain remnant voltages from the display pixel.



WO 2021/101859 A1

**Declarations under Rule 4.17:**

- *as to applicant's entitlement to apply for and be granted a patent (Rule 4.17(ii))*
- *as to the applicant's entitlement to claim the priority of the earlier application (Rule 4.17(iii))*

**Published:**

- *with international search report (Art. 21(3))*

## METHODS FOR DRIVING ELECTRO-OPTIC DISPLAYS

### REFERENCE TO RELATED APPLICATIONS

**[Para 1]** This application is related to and claims priority to U.S. Provisional Application 62/936,914 filed on November 18, 2019.

**[Para 2]** The entire disclosures of the aforementioned application is herein incorporated by reference.

### SUBJECT OF THE INVENTION

**[Para 3]** This invention relates to reflective electro-optic displays and materials for use in such displays. More specifically, this invention relates to displays with reduced remnant voltage and driving methods for reducing remnant voltage in electro-optic displays.

### BACKGROUND

**[Para 4]** Electro-optics displays driven by direct current (DC) imbalanced waveforms may produce a remnant voltage, this remnant voltage being ascertainable by measuring the open-circuit electrochemical potential of a display pixel. It has been found that remnant voltage is a more general phenomenon in electrophoretic and other impulse-driven electro-optic displays, both in cause(s) and effect(s). It has also been found that DC imbalances may cause long-term lifetime degradation of some electrophoretic displays.

**[Para 5]** The term “remnant voltage” is also sometimes used as a term of convenience referring to an overall phenomenon. However, the basis for the switching behavior of impulse-driven electro-optic displays is the application of a voltage impulse (the integral of voltage with respect to time) across the electro-optic medium. Remnant voltage may reach a peak value immediately after the application of a driving pulse, and thereafter may decay substantially exponentially. The persistence of the remnant voltage for a significant time period applies a “remnant impulse” to the electro-optic medium, and strictly speaking this remnant impulse, rather than the remnant voltage, may be responsible for the effects on the optical states of electro-optic displays normally considered as caused by remnant voltage.



**[Para 6]** In theory, the effect of remnant voltage should correspond directly to remnant impulse. In practice, however, the impulse switching model can lose accuracy at low voltages. Some electro-optic media have a threshold, such that a remnant voltage of about 1 V may not cause a noticeable change in the optical state of the medium after a drive pulse ends. However, other electro-optic media, including preferred electrophoretic media used in experiments described herein, a remnant voltage of about 0.5 V may cause a noticeable change in the optical state. Thus, two equivalent remnant impulses may differ in actual consequences, and it may be helpful to increase the threshold of the electro-optic medium to reduce the effect of remnant voltage. E Ink Corporation has produced electrophoretic media having a “small threshold” adequate to prevent remnant voltage experienced in some circumstances from immediately changing the display image after a drive pulse ends. If the threshold is inadequate or if the remnant voltage is too high, the display may present a kickback/self-erasing or self-improving phenomenon. Where the term “optical kickback” is used herein to describe a change in a pixel’s optical state which occurs at least partially a response to the discharge of the pixel’s remnant voltage.

**[Para 7]** Even when remnant voltages are below a small threshold, they may have a serious effect on image switching if they still persist when the next image update occurs. For example, suppose that during an image update of an electrophoretic display a +/-15 V drive voltage is applied to move the electrophoretic particles. If a +1 V remnant voltage persists from a prior update, the drive voltage would effectively be shifted from +15 V/-15 V to +16 V/-14 V. As a result, the pixel would be biased toward the dark or white state, depending on whether it has a positive or negative remnant voltage. Furthermore, this effect varies with elapsed time due to the decay rate of the remnant voltage. The electro-optic material in a pixel switched to white using a 15 V, 300 ms drive pulse immediately after a previous image update may actually experience a waveform closer to 16 V for 300 ms, whereas the material in a pixel switched to white one minute later using the exact same drive pulse (15 V, 300 ms) may actually experience a waveform closer to 15.2 V for 300 ms. Consequently the pixels may show noticeably different shades of white.

**[Para 8]** If the remnant voltage field has been created across multiple pixels by a prior image (say a dark line on a white background) then the remnant voltages may also be arrayed across the display in a similar pattern. In practical terms then, the most noticeable effect of remnant voltage on display performance may be ghosting. This problem is in

addition to the problem previously noted, namely that DC imbalance (e.g. 16 V/14 V instead of 15 V/15 V) may be a cause of slow lifetime degradation of the electro-optic medium.

**[Para 9]** If a remnant voltage decays slowly and is nearly constant, then its effect in shifting the waveform does not vary from image update to update and may actually create less ghosting than a remnant voltage that decays quickly. Thus the ghosting experienced by updating one pixel after 10 minutes and another pixel after 11 minutes is much less than the ghosting experienced by updating one pixel immediately and another pixel after 1 minute. Conversely, a remnant voltage that decays so quickly that it approaches zero before the next update occurs may in practice cause no detectable ghosting.

**[Para 10]** There are multiple potential sources of remnant voltage. It is believed (although some embodiments are in no way limited by this belief), that one large cause of remnant voltage is ionic polarization within the materials of the various layers forming the display.

**[Para 11]** To summarize, remnant voltage as a phenomenon can present itself as image ghosting or visual artifacts in a variety of ways, with a degree of severity that can vary with the elapsed times between image updates. Remnant voltage can also create a DC imbalance and reduce ultimate display lifetime. The effects of remnant voltage therefore may be deleterious to the quality of the electrophoretic or other electro-optic device and it is desirable to minimize both the remnant voltage itself, and the sensitivity of the optical states of the device to the influence of the remnant voltage.

**[Para 12]** Thus, discharging a remnant voltage of an electro-optic display may improve the quality of the displayed image, even in circumstances where the remnant voltage is already low. The inventors have recognized and appreciated that conventional techniques for discharging a remnant voltage of an electro-optic display may not fully discharge the remnant voltage. That is, conventional techniques of discharging the remnant voltage may result in the electro-optic display retaining at least a low remnant voltage. Thus, techniques for better discharging remnant voltages from electro-optic displays are needed.

## SUMMARY OF INVENTION

**[Para 13]** The invention provides a method for driving an electro-optic display having a plurality of display pixels and each of the plurality of display pixels is associated with a



display transistor, the method includes applying a first voltage to a transistor associated with a display pixel for a first duration of time to drain remnant voltages from the display pixel, applying a second voltage to the transistor for a second duration of time to stop the draining of remnant voltages from the display pixel, and applying a third voltage to the transistor for a third duration of time to drain remnant voltages from the display pixel.

### **BRIEF DESCRIPTION OF DRAWINGS**

**[Para 14]** FIG. 1 is a circuit diagram representing an electrophoretic display in accordance with the subject matter disclosed herein;

**[Para 15]** FIG. 2 shows a circuit model of the electro-optic imaging layer in accordance with the subject matter disclosed herein;

**[Para 16]** FIG. 3 illustrates an exemplary driving method in accordance with the subject matter disclosed herein;

**[Para 17]** FIG. 4 illustrates another driving method in accordance with the subject matter disclosed herein;

**[Para 18]** FIG. 5 illustrates yet another driving method in accordance with the subject matter disclosed herein;

**[Para 19]** FIG. 6 illustrates an additional driving method in accordance with the subject matter disclosed herein;

**[Para 20]** FIG. 7 illustrates an alternative driving method in accordance with the subject matter disclosed herein; and

**[Para 21]** FIG. 8 illustrates another driving method in accordance with the subject matter disclosed herein.

### **DETAILED DESCRIPTION**

**[Para 22]** The term "electro-optic", as applied to a material or a display, is used herein in its conventional meaning in the imaging art to refer to a material having first and second display states differing in at least one optical property, the material being changed from its first to its second display state by application of an electric field to the material. Although the optical property is typically color perceptible to the human eye, it may be another optical property, such as optical transmission, reflectance, luminescence or, in the case of

displays intended for machine reading, pseudo-color in the sense of a change in reflectance of electromagnetic wavelengths outside the visible range.

**[Para 23]** The term "gray state" is used herein in its conventional meaning in the imaging art to refer to a state intermediate two extreme optical states of a pixel, and does not necessarily imply a black-white transition between these two extreme states. For example, several of the E Ink patents and published applications referred to below describe electrophoretic displays in which the extreme states are white and deep blue, so that an intermediate "gray state" would actually be pale blue. Indeed, as already mentioned, the change in optical state may not be a color change at all. The terms "black" and "white" may be used hereinafter to refer to the two extreme optical states of a display, and should be understood as normally including extreme optical states which are not strictly black and white, for example, the aforementioned white and dark blue states. The term "monochrome" may be used hereinafter to denote a drive scheme which only drives pixels to their two extreme optical states with no intervening gray states.

**[Para 24]** Much of the discussion below will focus on methods for driving one or more pixels of an electro-optic display through a transition from an initial gray level to a final gray level (which may or may not be different from the initial gray level). The term "waveform" will be used to denote the entire voltage against time curve used to effect the transition from one specific initial gray level to a specific final gray level. Typically such a waveform will comprise a plurality of waveform elements; where these elements are essentially rectangular (i.e., where a given element comprises application of a constant voltage for a period of time); the elements may be called "pulses" or "drive pulses". The term "drive scheme" denotes a set of waveforms sufficient to effect all possible transitions between gray levels for a specific display. A display may make use of more than one drive scheme; for example, the aforementioned U. S. Patent No. 7,012,600 teaches that a drive scheme may need to be modified depending upon parameters such as the temperature of the display or the time for which it has been in operation during its lifetime, and thus a display may be provided with a plurality of different drive schemes to be used at differing temperature etc. A set of drive schemes used in this manner may be referred to as "a set of related drive schemes." It is also possible, as described in several of the aforementioned MEDEOD applications, to use more than one drive scheme simultaneously in different



areas of the same display, and a set of drive schemes used in this manner may be referred to as "a set of simultaneous drive schemes."

**[Para 25]** Some electro-optic materials are solid in the sense that the materials have solid external surfaces, although the materials may, and often do, have internal liquid- or gas-filled spaces. Such displays using solid electro-optic materials may hereinafter for convenience be referred to as "solid electro-optic displays". Thus, the term "solid electro-optic displays" includes rotating bichromal member displays, encapsulated electrophoretic displays, microcell electrophoretic displays and encapsulated liquid crystal displays.

**[Para 26]** The terms "bistable" and "bistability" are used herein in their conventional meaning in the art to refer to displays comprising display elements having first and second display states differing in at least one optical property, and such that after any given element has been driven, by means of an addressing pulse of finite duration, to assume either its first or second display state, after the addressing pulse has terminated, that state will persist for at least several times, for example at least four times, the minimum duration of the addressing pulse required to change the state of the display element. It is shown in U.S. Patent No. 7,170,670 that some particle-based electrophoretic displays capable of gray scale are stable not only in their extreme black and white states but also in their intermediate gray states, and the same is true of some other types of electro-optic displays. This type of display is properly called "multi-stable" rather than bistable, although for convenience the term "bistable" may be used herein to cover both bistable and multi-stable displays.

**[Para 27]** Several types of electro-optic displays are known. One type of electro-optic display is a rotating bichromal member type as described, for example, in U.S. Patents Nos. 5,808,783; 5,777,782; 5,760,761; 6,054,071 6,055,091; 6,097,531; 6,128,124; 6,137,467; and 6,147,791 (although this type of display is often referred to as a "rotating bichromal ball" display, the term "rotating bichromal member" is preferred as more accurate since in some of the patents mentioned above the rotating members are not spherical). Such a display uses a large number of small bodies (typically spherical or cylindrical) which have two or more sections with differing optical characteristics and an internal dipole. These bodies are suspended within liquid-filled vacuoles within a matrix, the vacuoles being filled with liquid so that the bodies are free to rotate. The appearance of the display is changed by applying an electric field thereto, thus rotating the bodies to



various positions and varying which of the sections of the bodies is seen through a viewing surface. This type of electro-optic medium is typically bistable.

**[Para 28]** One type of electro-optic display, which has been the subject of intense research and development for a number of years, is the particle-based electrophoretic display, in which a plurality of charged particles move through a fluid under the influence of an electric field. Electrophoretic displays can have attributes of good brightness and contrast, wide viewing angles, state bistability, and low power consumption when compared with liquid crystal displays. Nevertheless, problems with the long-term image quality of these displays have prevented their widespread usage. For example, particles that make up electrophoretic displays tend to settle, resulting in inadequate service-life for these displays.

**[Para 29]** As noted above, electrophoretic media require the presence of a fluid. In most prior art electrophoretic media, this fluid is a liquid, but electrophoretic media can be produced using gaseous fluids; see, for example, Kitamura, T., et al., "Electrical toner movement for electronic paper-like display", IDW Japan, 2001, Paper HCS1-1, and Yamaguchi, Y., et al., "Toner display using insulative particles charged triboelectrically", IDW Japan, 2001, Paper AMD4-4). See also U.S. Patents Nos. 7,321,459 and 7,236,291. Such gas-based electrophoretic media appear to be susceptible to the same types of problems due to particle settling as liquid-based electrophoretic media, when the media are used in an orientation which permits such settling, for example in a sign where the medium is disposed in a vertical plane. Indeed, particle settling appears to be a more serious problem in gas-based electrophoretic media than in liquid-based ones, since the lower viscosity of gaseous suspending fluids as compared with liquid ones allows more rapid settling of the electrophoretic particles.

**[Para 30]** Numerous patents and applications assigned to or in the names of the Massachusetts Institute of Technology (MIT) and E Ink Corporation describe various technologies used in encapsulated electrophoretic and other electro-optic media. Such encapsulated media comprise numerous small capsules, each of which itself comprises an internal phase containing electrophoretically-mobile particles in a fluid medium, and a capsule wall surrounding the internal phase. Typically, the capsules are themselves held within a polymeric binder to form a coherent layer positioned between two electrodes. The technologies described in these patents and applications include:

**[Para 31]** (a) Electrophoretic particles, fluids and fluid additives; see for example U.S. Patents Nos. 7,002,728 and 7,679,814;

**[Para 32]** (b) Capsules, binders and encapsulation processes; see for example U.S. Patents Nos. 6,922,276 and 7,411,719;

**[Para 33]** (c) Microcell structures, wall materials, and methods of forming microcells; see for example United States Patents Nos. 7,072,095 and 9,279,906;

**[Para 34]** (d) Methods for filling and sealing microcells; see for example United States Patents Nos. 7,144,942 and 7,715,088;

**[Para 35]** (e) Films and sub-assemblies containing electro-optic materials; see for example U.S. Patents Nos. 6,982,178 and 7,839,564;

**[Para 36]** (f) Backplanes, adhesive layers and other auxiliary layers and methods used in displays; see for example U.S. Patents Nos. 7,116,318 and 7,535,624;

**[Para 37]** (g) Color formation and color adjustment; see for example U.S. Patents Nos. 7,075,502 and 7,839,564.

**[Para 38]** (h) Applications of displays; see for example U.S. Patents Nos. 7,312,784; 8,009,348;

**[Para 39]** (i) Non-electrophoretic displays, as described in U.S. Patents Nos. 6,241,921 and U.S. Patent Application Publication No. 2015/0277160; and applications of encapsulation and microcell technology other than displays; see for example U.S. Patent Application Publications Nos. 2015/0005720 and 2016/0012710; and

**[Para 40]** Methods for driving displays; see for example U.S. Patents Nos. 5,930,026; 6,445,489; 6,504,524; 6,512,354; 6,531,997; 6,753,999; 6,825,970; 6,900,851; 6,995,550; 7,012,600; 7,023,420; 7,034,783; 7,061,166; 7,061,662; 7,116,466; 7,119,772; 7,177,066; 7,193,625; 7,202,847; 7,242,514; 7,259,744; 7,304,787; 7,312,794; 7,327,511; 7,408,699; 7,453,445; 7,492,339; 7,528,822; 7,545,358; 7,583,251; 7,602,374; 7,612,760; 7,679,599; 7,679,813; 7,683,606; 7,688,297; 7,729,039; 7,733,311; 7,733,335; 7,787,169; 7,859,742; 7,952,557; 7,956,841; 7,982,479; 7,999,787; 8,077,141; 8,125,501; 8,139,050; 8,174,490; 8,243,013; 8,274,472; 8,289,250; 8,300,006; 8,305,341; 8,314,784; 8,373,649; 8,384,658; 8,456,414; 8,462,102; 8,537,105; 8,558,783; 8,558,785; 8,558,786; 8,558,855; 8,576,164; 8,576,259; 8,593,396; 8,605,032; 8,643,595; 8,665,206; 8,681,191; 8,730,153; 8,810,525; 8,928,562; 8,928,641; 8,976,444; 9,013,394; 9,019,197; 9,019,198; 9,019,318; 9,082,352; 9,171,508; 9,218,773; 9,224,338; 9,224,342; 9,224,344; 9,230,492; 9,251,736; 9,262,973;



9,269,311; 9,299,294; 9,373,289; 9,390,066; 9,390,661; and 9,412,314; and U.S. Patent Applications Publication Nos. 2003/0102858; 2004/0246562; 2005/0253777; 2007/0070032; 2007/0076289; 2007/0091418; 2007/0103427; 2007/0176912; 2007/0296452; 2008/0024429; 2008/0024482; 2008/0136774; 2008/0169821; 2008/0218471; 2008/0291129; 2008/0303780; 2009/0174651; 2009/0195568; 2009/0322721; 2010/0194733; 2010/0194789; 2010/0220121; 2010/0265561; 2010/0283804; 2011/0063314; 2011/0175875; 2011/0193840; 2011/0193841; 2011/0199671; 2011/0221740; 2012/0001957; 2012/0098740; 2013/0063333; 2013/0194250; 2013/0249782; 2013/0321278; 2014/0009817; 2014/0085355; 2014/0204012; 2014/0218277; 2014/0240210; 2014/0240373; 2014/0253425; 2014/0292830; 2014/0293398; 2014/0333685; 2014/0340734; 2015/0070744; 2015/0097877; 2015/0109283; 2015/0213749; 2015/0213765; 2015/0221257; 2015/0262255; 2016/0071465; 2016/0078820; 2016/0093253; 2016/0140910; and 2016/0180777.

**[Para 41]** Many of the aforementioned patents and applications recognize that the walls surrounding the discrete microcapsules in an encapsulated electrophoretic medium could be replaced by a continuous phase, thus producing a so-called polymer-dispersed electrophoretic display, in which the electrophoretic medium comprises a plurality of discrete droplets of an electrophoretic fluid and a continuous phase of a polymeric material, and that the discrete droplets of electrophoretic fluid within such a polymer-dispersed electrophoretic display may be regarded as capsules or microcapsules even though no discrete capsule membrane is associated with each individual droplet; see for example, the aforementioned 2002/0131147. Accordingly, for purposes of the present application, such polymer-dispersed electrophoretic media are regarded as sub-species of encapsulated electrophoretic media.

**[Para 42]** A related type of electrophoretic display is a so-called “microcell electrophoretic display.” In a microcell electrophoretic display, the charged particles and the suspending fluid are not encapsulated within microcapsules but instead are retained within a plurality of cavities formed within a carrier medium, e.g., a polymeric film. See, for example, International Application Publication No. WO 02/01281, and published U.S. Application No. 2002/0075556, both assigned to Sipix Imaging, Inc.

**[Para 43]** Many of the aforementioned E Ink and MIT patents and applications also contemplate microcell electrophoretic displays and polymer-dispersed electrophoretic displays. The term “encapsulated electrophoretic displays” can refer to all such display types, which may also be described collectively as “microcavity electrophoretic displays” to generalize across the morphology of the walls.

**[Para 44]** Another type of electro-optic display is an electro-wetting display developed by Philips and described in Hayes, R. A., et al., “Video-Speed Electronic Paper Based on Electrowetting,” *Nature*, 425, 383-385 (2003). It is shown in copending application Ser. No. 10/711,802, filed Oct. 6, 2004, that such electro-wetting displays can be made bistable.

**[Para 45]** Other types of electro-optic materials may also be used. Of particular interest, bistable ferroelectric liquid crystal displays (FLCs) are known in the art and have exhibited remnant voltage behavior.

**[Para 46]** Although electrophoretic media may be opaque (since, for example, in many electrophoretic media, the particles substantially block transmission of visible light through the display) and operate in a reflective mode, some electrophoretic displays can be made to operate in a so-called “shutter mode” in which one display state is substantially opaque and one is light-transmissive. See, for example, the patents U.S. Pat. Nos. 6,130,774 and 6,172,798, and U.S. Pat. Nos. 5,872,552; 6,144,361; 6,271,823; 6,225,971; and 6,184,856. Dielectrophoretic displays, which are similar to electrophoretic displays but rely upon variations in electric field strength, can operate in a similar mode; see U.S. Pat. No. 4,418,346. Other types of electro-optic displays may also be capable of operating in shutter mode.

**[Para 47]** A high-resolution display may include individual pixels which are addressable without interference from adjacent pixels. One way to obtain such pixels is to provide an array of non-linear elements, such as transistors or diodes, with at least one non-linear element associated with each pixel, to produce an “active matrix” display. An addressing or pixel electrode, which addresses one pixel, is connected to an appropriate voltage source through the associated non-linear element. When the non-linear element is a transistor, the pixel electrode may be connected to the drain of the transistor, and this arrangement will be assumed in the following description, although it is essentially arbitrary and the pixel electrode could be connected to the source of the transistor. In



high-resolution arrays, the pixels may be arranged in a two-dimensional array of rows and columns, such that any specific pixel is uniquely defined by the intersection of one specified row and one specified column. The sources of all the transistors in each column may be connected to a single column electrode, while the gates of all the transistors in each row may be connected to a single row electrode; again the assignment of sources to rows and gates to columns may be reversed if desired.

**[Para 48]** The display may be written in a row-by-row manner. The row electrodes are connected to a row driver, which may apply to a selected row electrode a voltage such as to ensure that all the transistors in the selected row are conductive, while applying to all other rows a voltage such as to ensure that all the transistors in these non-selected rows remain non-conductive. The column electrodes are connected to column drivers, which place upon the various column electrodes voltages selected to drive the pixels in a selected row to their desired optical states. (The aforementioned voltages are relative to a common front electrode which may be provided on the opposed side of the electro-optic medium from the non-linear array and extends across the whole display. As is known in the art, voltage is relative and a measure of a charge differential between two points. One voltage value is relative to another voltage value. For example, zero voltage (“0V”) refers to having no voltage differential relative to another voltage.) After a pre-selected interval known as the “line address time,” a selected row is deselected, another row is selected, and the voltages on the column drivers are changed so that the next line of the display is written.

**[Para 49]** However, in use, certain waveforms may produce a remnant voltage to pixels of an electro-optic display, and as evident from the discussion above, this remnant voltage produces several unwanted optical effects and is in general undesirable.

**[Para 50]** As presented herein, a “shift” in the optical state associated with an addressing pulse refers to a situation in which a first application of a particular addressing pulse to an electro-optic display results in a first optical state (e.g., a first gray tone), and a subsequent application of the same addressing pulse to the electro-optic display results in a second optical state (e.g., a second gray tone). Remnant voltages may give rise to shifts in the optical state because the voltage applied to a pixel of the electro-optic display during application of an addressing pulse includes the sum of the remnant voltage and the voltage of the addressing pulse.

**[Para 51]** A “drift” in the optical state of a display over time refers to a situation in which the optical state of an electro-optic display changes while the display is at rest (e.g., during a period in which an addressing pulse is not applied to the display). Remnant voltages may give rise to drifts in the optical state because the optical state of a pixel may depend on the pixel’s remnant voltage, and a pixel’s remnant voltage may decay over time.

**[Para 52]** As discussed above, “ghosting” refers to a situation in which, after the electro-optic display has been rewritten, traces of the previous image(s) are still visible. Remnant voltages may give rise to “edge ghosting,” a type of ghosting in which an outline (edge) of a portion of a previous image remains visible.

**[Para 53]** Where the term “optical kickback” is used herein to describe a change in a pixel’s optical state which occurs at least partially response to the discharge of the pixel’s remnant voltage.

**[Para 54]** FIG. 1 shows a schematic of a pixel 100 of an electro-optic display in accordance with the subject matter submitted herein. Pixel 100 may include an imaging film 110. In some embodiments, imaging film 110 may be bistable. In some embodiments, imaging film 110 may include, without limitation, an encapsulated electrophoretic imaging film, which may include, for example, charged pigment particles.

**[Para 55]** Imaging film 110 may be disposed between a front electrode 102 and a rear electrode 104. Front electrode 102 may be formed between the imaging film and the front of the display. In some embodiments, front electrode 102 may be transparent. In some embodiments, front electrode 102 may be formed of any suitable transparent material, including, without limitation, indium tin oxide (ITO). Rear electrode 104 may be formed opposite a front electrode 102. In some embodiments, a parasitic capacitance (not shown) may be formed between front electrode 102 and rear electrode 104.

**[Para 56]** Pixel 100 may be one of a plurality of pixels. The plurality of pixels may be arranged in a two-dimensional array of rows and columns to form a matrix, such that any specific pixel is uniquely defined by the intersection of one specified row and one specified column. In some embodiments, the matrix of pixels may be an “active matrix,” in which each pixel is associated with at least one non-linear circuit element 120. The non-linear circuit element 120 may be coupled between back-plate electrode 104 and an addressing electrode 108. In some embodiments, non-linear element 120 may include a diode and/or a transistor, including, without limitation, a MOSFET. The drain (or source)



of the MOSFET may be coupled to back-plate electrode 104, the source (or drain) of the MOSFET may be coupled to addressing electrode 108, and the gate 106 of the MOSFET may be coupled to a driver and configured to control the activation and deactivation of the MOSFET. (For simplicity, the terminal of the MOSFET coupled to back-plate electrode 104 will be referred to as the MOSFET's drain, and the terminal of the MOSFET coupled to addressing electrode 108 will be referred to as the MOSFET's source. However, one of ordinary skill in the art will recognize that, in some embodiments, the source and drain of the MOSFET may be interchanged.)

**[Para 57]** In some embodiments of the active matrix, the addressing electrodes 108 of all the pixels in each column may be connected to a same column electrode, and the gate 106 of all the transistors coupled to all the pixels in each row may be connected to a same row electrode. The row electrodes may be connected to a row driver, which may select one or more rows of pixels by applying to the selected row electrodes a voltage sufficient to activate the non-linear elements 120 of all the pixels 100 in the selected row(s). The column electrodes may be connected to column drivers, which may place upon the transistor gate 106 of a selected (activated) pixel a voltage suitable for driving the pixel into a desired optical state. The voltage applied to an addressing electrode 108 may be relative to the voltage applied to the pixel's front-plate electrode 102 (e.g., a voltage of approximately zero volts). In some embodiments, the front-plate electrodes 102 of all the pixels in the active matrix may be coupled to a common electrode.

**[Para 58]** In some embodiments, the pixels 100 of the active matrix may be written in a row-by-row manner. For example, a row of pixels may be selected by the row driver, and the voltages corresponding to the desired optical states for the row of pixels may be applied to the pixels by the column drivers. After a pre-selected interval known as the "line address time," the selected row may be deselected, another row may be selected, and the voltages on the column drivers may be changed so that another line of the display is written.

**[Para 59]** FIG. 2 shows a circuit model of the electro-optic imaging layer 110 disposed between the front electrode 102 and the rear electrode 104 in accordance with the subject matter presented herein. Resistor 202 and capacitor 204 may represent the resistance and capacitance of the electro-optic imaging layer 110, the front electrode 102 and the rear electrode 104, including any adhesive layers. Resistor 212 and capacitor 214 may

represent the resistance and capacitance of a lamination adhesive layer. Capacitor 216 may represent a capacitance that may form between the front electrode 102 and the back electrode 104, for example, interfacial contact areas between layers, such as the interface between the imaging layer and the lamination adhesive layer and/or between the lamination adhesive layer and the backplane electrode. A voltage  $V_i$  across a pixel's imaging film 110 may include the pixel's remnant voltage.

**[Para 60]** The discharge of the remnant voltage of a pixel may be initiated and/or controlled by applying any suitable set of signals to a pixel, including, without limitation, a set of signals illustrated in more details below in Figure 3, and Figures 4-8.

**[Para 61]** FIG. 3 illustrates one exemplary driving method 300 in accordance with the subject matter disclosed herein. Normally, post-drive discharge of remnant voltages may involve the application of a discharge voltage (e.g., a voltage applied to the gates 106 of the transistors 120 associated with each display pixel) that increases the pixel transistor transconductance sufficiently which allows remnant voltage to be drained from display pixels. In some embodiments, this discharge voltage value may be chosen to be the same as the gate on voltage (i.e., a voltage sufficiently large and applied to the gates of transistors 120 associated with display pixels such that the transistor are conducting current and drive the display pixels) employed to select rows of display pixels during an active-matrix scanning. Alternatively, as described in United States Patent Application No. 15/266,554, which is incorporated herein in its entirety, this discharge voltage may be chosen to be a value of lesser magnitude but sufficiently large in amplitude to induce sufficient pixel transistor conductance to allow remnant voltage to be drained off from display pixels. This discharge voltage may be constant or could be time-varying. For example, the discharge voltage may be designed to decay approximately exponentially during a post-drive discharge phase. In some other embodiments, the discharge voltage may be applied intermittently across a designated post drive discharge time. Specifically, the gate voltages may be set to a desired discharge voltage for two or more time segments during a post-drive time range, and at a different voltage the rest of the post-drive discharge time. In practice, in some embodiments, instead of a single different voltage, there may be multiple alternate voltages. However, it should be appreciated that it may be desirable that these alternative voltage do not induce as much to a pixel thin-film transistor compared to when a discharge voltage was applied. In use, this means that the different



voltages or the alternate voltages values are somewhere in the range between the discharge voltage and the gate off voltage employed during a typical display scanning, inclusive of the gate off voltage. While a convenient alternate voltage may be zero volts, which in this case, zero volts is the same voltage that the source lines are held at during this discharge time period, it may be advantageous to have the alternate voltage to be of opposite sign or polarity as the discharge voltage. The advantage here being that the voltage of opposite sign can at least partially offset the voltage-induced stress to the transistor imposed by the driving voltage.

**[Para 62]** The subject matter disclosed herein introduces several advantages, one being a reduction in TFT transconductance stress when discharge voltages are applied to TFT gates during a discharge of remnant voltage. The TFT transconductance stress can accumulate over time and cause degradations in display performance. The driving methods described herein can reduce the integrated time the discharge voltage is applied to the TFT in a way that preserves the efficacy of post-drive discharge better than the alternative, for example, reducing the discharge voltage stress by only reducing the time of post-drive discharge.

**[Para 63]** Furthermore, by segmenting the post-drive discharge into more than one portions with different voltage values, in some instances where one of these portion may be of a voltage level that carries an opposite (e.g., a negative voltage, compared to the positive voltage during a TFT discharge segment) amplitude to that of the discharge portion. In this configuration, at least portions of the accumulated transconductance stress may be rolled back or reduced, thereby improving the TFT liability and performance.

**[Para 64]** As illustrated in Figure 3, one embodiment of a driving method for discharging remnant charges to reduce remnant voltages may include three driving segments or time intervals 302, 304 and 306. In the time interval 302, a discharge voltage  $V_{PDD}$  308 may be applied to a pixel transistor to create a conduction path for discharging the remnant charges. In some embodiments, this discharge voltage  $V_{PDD}$  308 may be a value of lesser magnitude but sufficiently large in amplitude to induce sufficient pixel transistor conductance to allow remnant voltage to drain off of pixels. In this time interval 302, the pixel voltage  $V_{pixel}$  may be brought to zero during this time interval 302 when the discharge voltage  $V_{PDD}$  308 is applied, and the remnant charge is dissipated from the pixel

through current  $J_{\text{discharge}}$ . Subsequently, during a dwelling period 304, the discharge voltage  $V_{\text{PDD}}$  may be set to be equal to a nominal gate off voltage 310, which induces the pixel voltage  $V_{\text{pixel}}$  to a zero-current value, and at this time, the pixel current  $J_{\text{discharge}}$  becomes zero and no remnant charges are dissipated. Following this dwelling period 304, the pixel voltage  $V_{\text{PDD}}$  308 may be turned on again to a nominal discharge voltage 312 in another discharge period 306. In this second discharge period, additional remnant charges may be dissipated.

**[Para 65]** In some other embodiments, instead of turning the pixel voltage  $V_{\text{PDD}}$  to a nominal gate off voltage as illustrated above, the pixel voltage  $V_{\text{PDD}}$  may be set to zero volts, and the discharge cycle can oscillate between a nominal discharge voltage), and the zero volt level, as illustrated in Figure 4. It should be appreciated that segment durations of the discharge cycles and the dwelling periods can vary depending on the application. For example, as illustrated in Figure 5, the discharge cycle 404 may be pre-set to be of 40% of a duty cycle (i.e., a complete duty cycle can be the sum of cycle 402 and 404).

**[Para 66]** In some other embodiments, the nominal gate off voltage may have a longer duration than the discharge voltage  $V_{\text{PDD}}$ . For example, as shown in FIG. 6, the nominal gate off voltage 604 may be of 60% of a duty cycle while the discharge voltage  $V_{\text{PDD}}$  602 is of 40% of the duty cycle.

**[Para 67]** In yet another embodiment, drive scheme may include discharge voltage  $V_{\text{PDD}}$  and nominal gate off voltages of different time durations. Meaning, within a driving sequence, the discharge voltage  $V_{\text{PDD}}$  cycles and/or the gate off voltage cycles may differ in duration tailored to specific display applications. For example, as illustrated in FIG. 7, the discharge voltage cycle 702 may be longer in duration than the discharge voltage cycle 706. Still further, likewise the gate off voltage cycles may differ in durations as well. For example, as illustrated in FIG. 8, not only the discharge voltage  $V_{\text{PDD}}$  cycles have different durations (e.g., cycle 802 is longer in duration than cycle 806, which itself is longer in duration than cycle 808), the gate off voltage cycles may also have different durations (e.g., cycle 810 is longer in duration than cycle 804). And the duration variation in the above mentioned cycles may be irregular in nature.

**[Para 68]** It will be apparent to those skilled in the art that numerous changes and modifications can be made to the specific embodiments of the invention described above



without departing from the scope of the invention. Accordingly, the whole of the foregoing description is to be interpreted in an illustrative and not in a limitative sense.

**CLAIMS**

1. A method for driving an electro-optic display, the display having a plurality of display pixels and each of the plurality of display pixels is associated with a display transistor, the method comprising:
  - applying a first voltage to a transistor associated with a display pixel for a first duration of time to drain remnant voltages from the display pixel;
  - applying a second voltage to the transistor for a second duration of time to stop the draining of remnant voltages from the display pixel; and
  - applying a third voltage to the transistor for a third duration of time to drain remnant voltages from the display pixel.
2. The method of claim 1 wherein the first voltage is a gate on voltage.
3. The method of claim 2 wherein the third voltage is a gate on voltage.
4. The method of claim 1 wherein the second voltage is zero volts.
5. The method of claim 1 wherein the length of the first duration of time is the same as the second duration of time.
6. The method of claim 1 wherein the length of the second duration of time is configured to reduce stress on the transistor.
7. The method of claim 1 wherein the length of the first duration of time is the same as the third duration of time.
8. The method of claim 1 wherein the length of the second duration of time is the same as the third duration of time.
9. The method of claim 1 wherein the length of the first duration of time is different from the second duration of time.
10. The method of claim 1 wherein the length of the first duration of time is different from the third duration of time.



11. The method of claim 1 wherein the second voltage has an opposite voltage polarity as the first voltage.
12. The method of claim 1 wherein the second voltage has an opposite voltage polarity as the third voltage.
13. The method of claim 1 wherein the second voltage is a nominal gate off voltage.
14. The method of claim 1 further comprising applying a fourth voltage to the transistor for a fourth duration of time to stop the draining of remnant voltages from the display pixel.
15. The method of claim 14 wherein the length of the fourth duration of time is configured to reduce stress in the transistor.
16. The method of claim 14 further comprising applying a fifth voltage to the transistor for a fifth duration of time to drain remnant voltages from the display pixel.
17. The method of claim 16 wherein the fourth duration of time has a different length than the fifth duration of time.
18. The method of claim 16 wherein the length of the fourth duration of time is the same as the fifth duration of time.
19. The method of claim 16 wherein the fourth duration of time has a different length than the second duration of time.
20. The method of claim 16 wherein the length of the fourth duration of time is the same as the second duration of time.

100

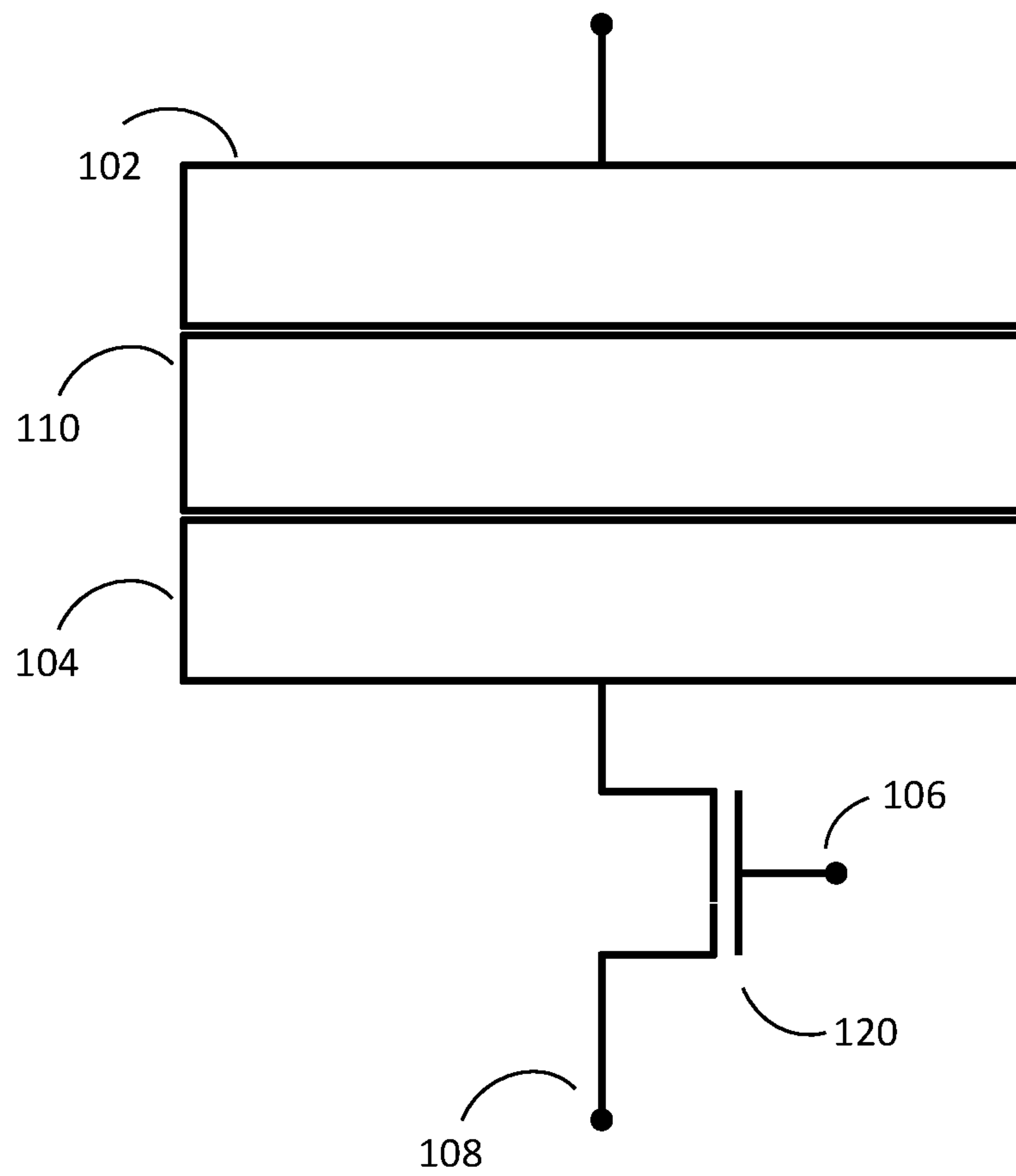

FIG. 1



200

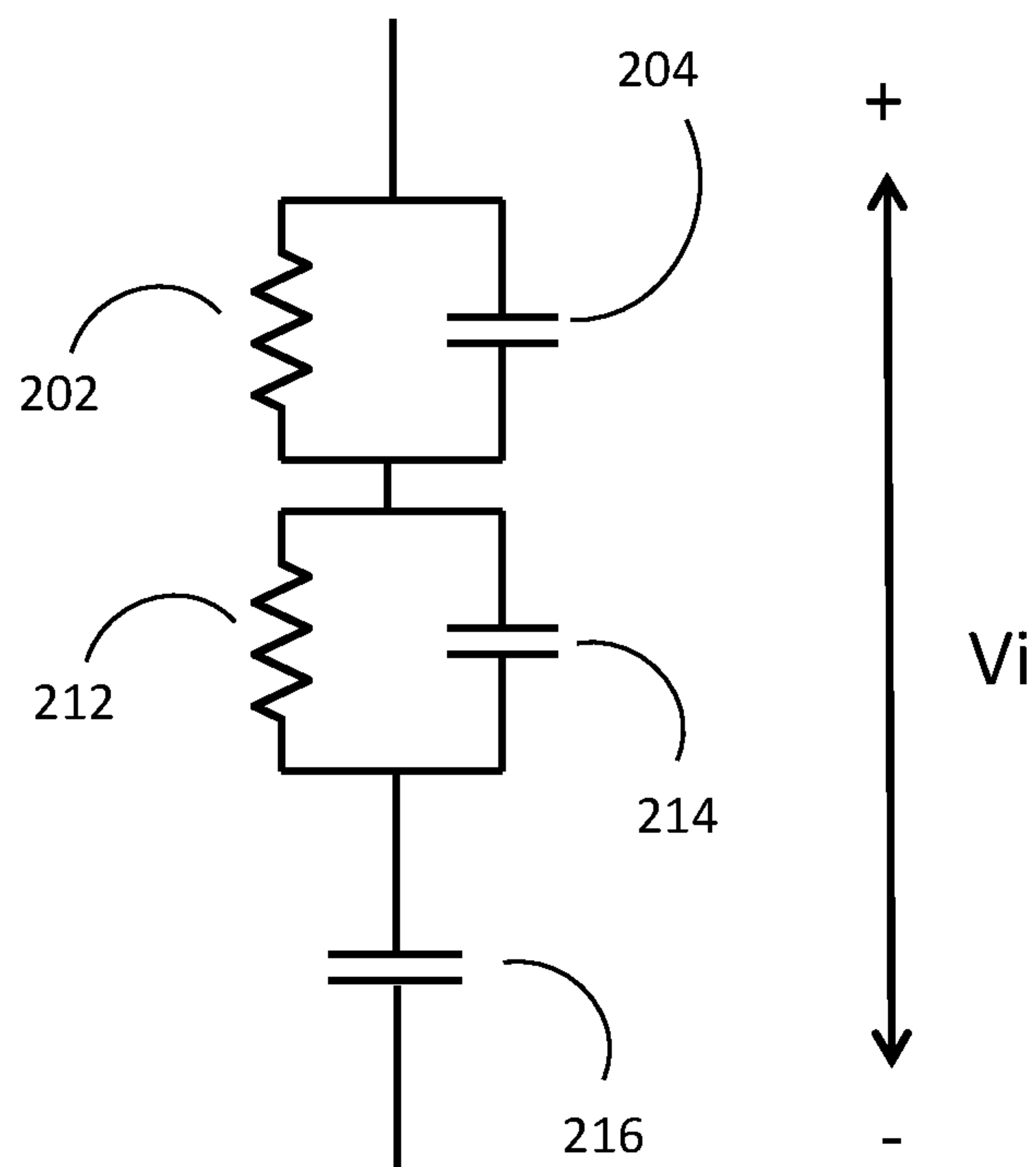

FIG. 2

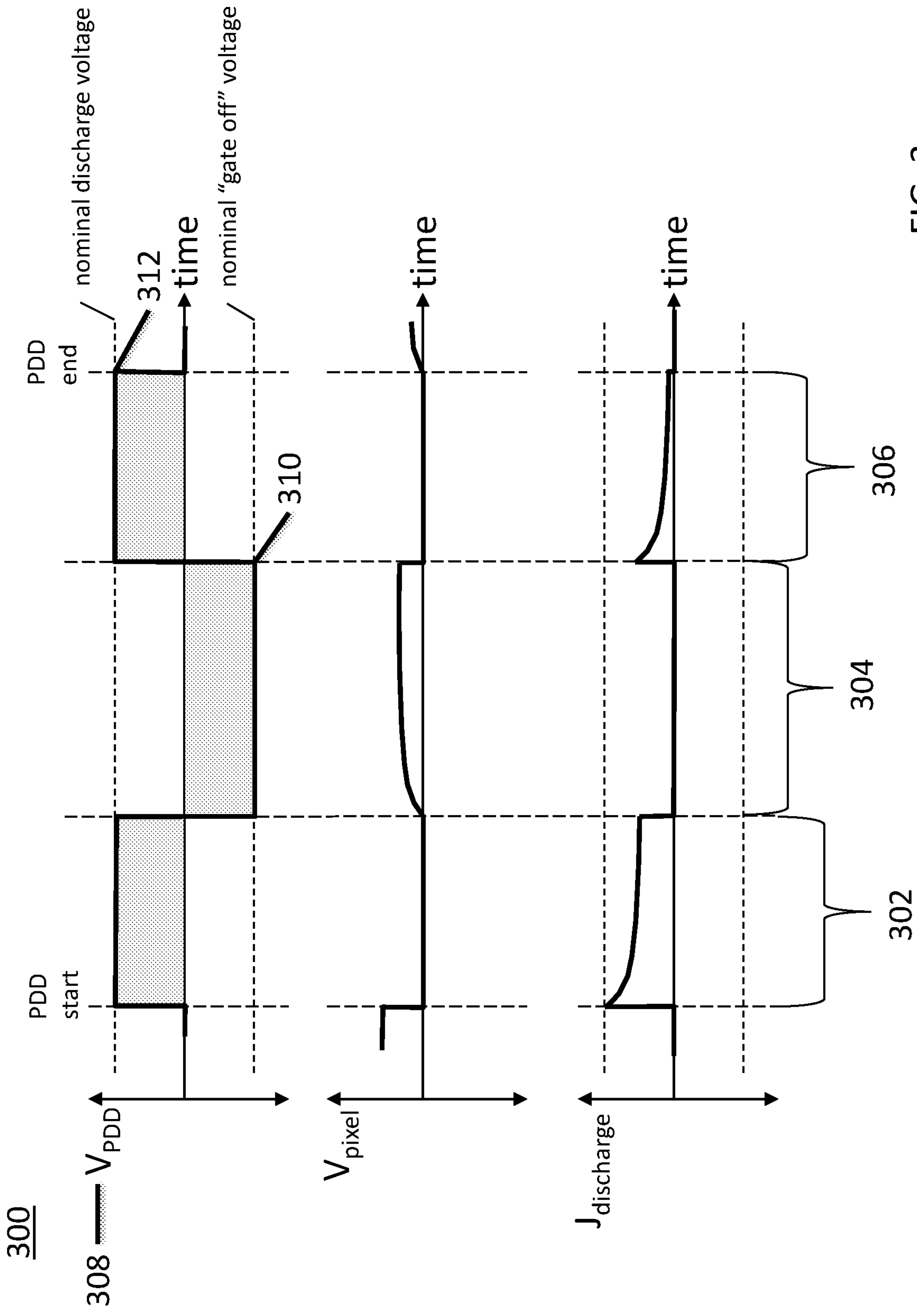

FIG. 3



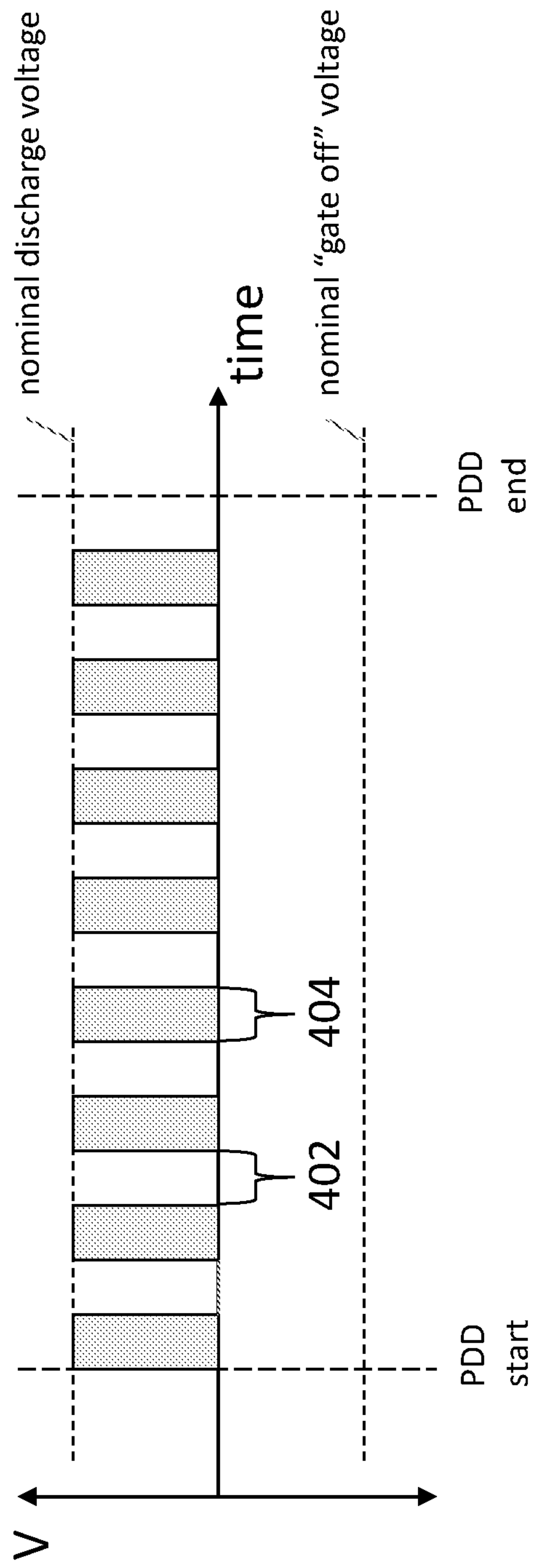

FIG. 4

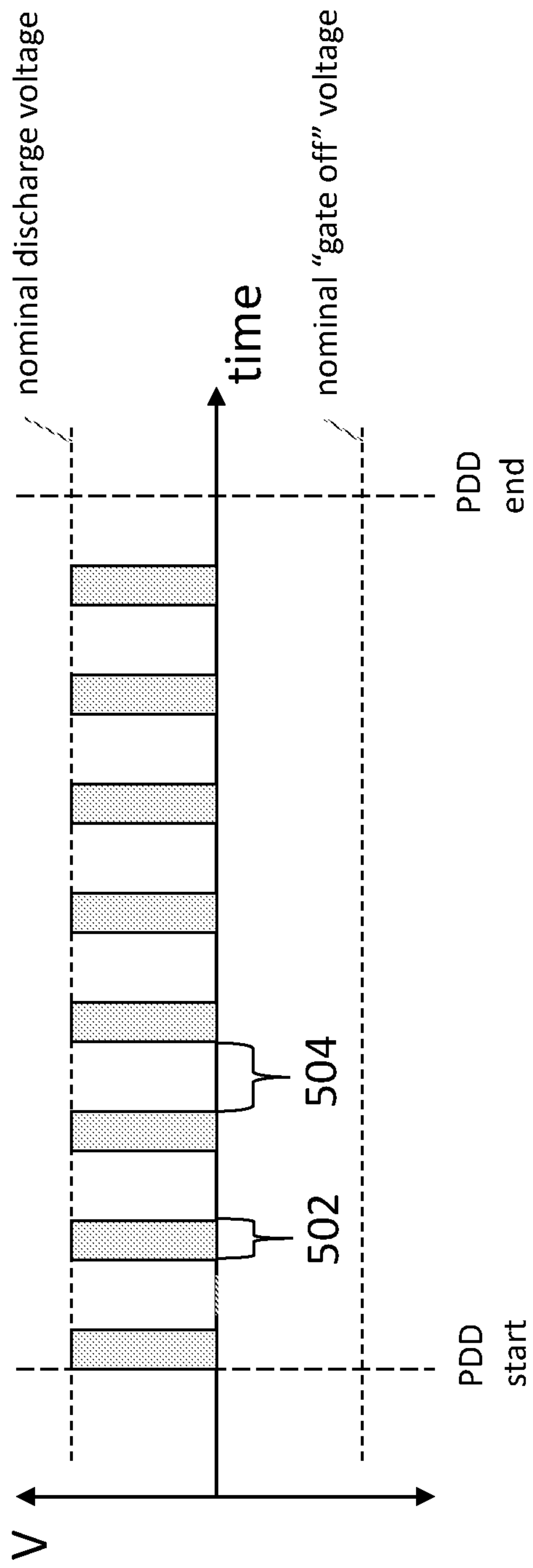

FIG. 5



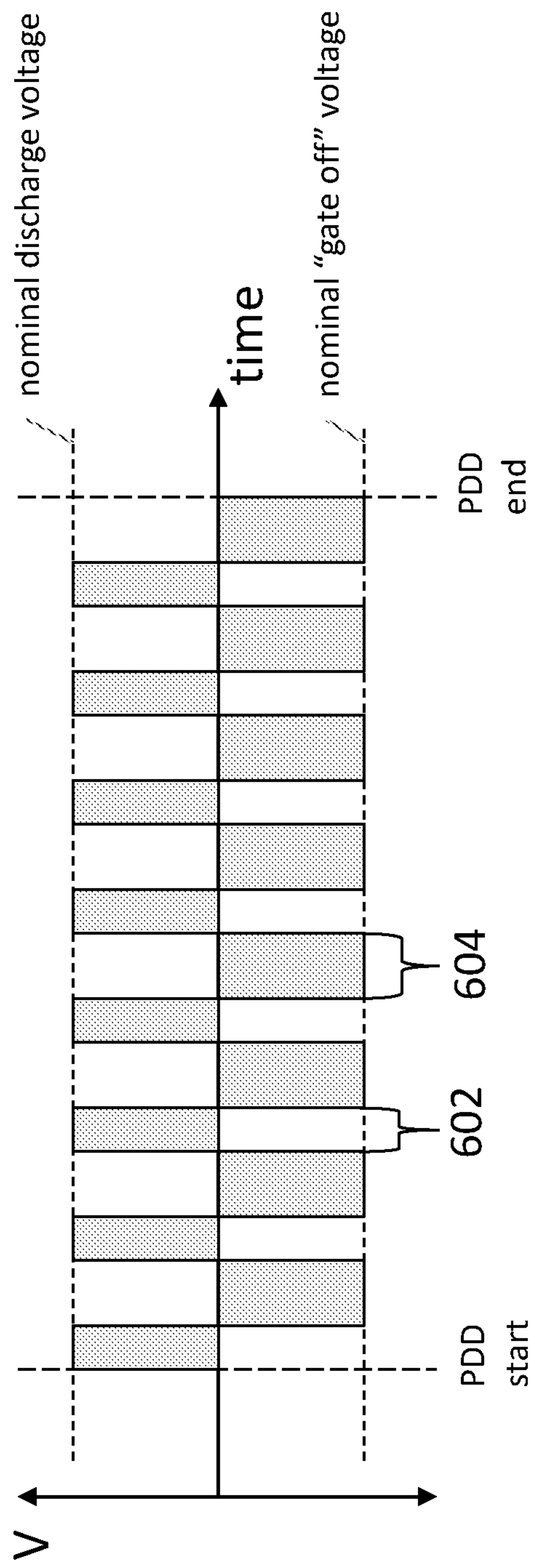

FIG. 6

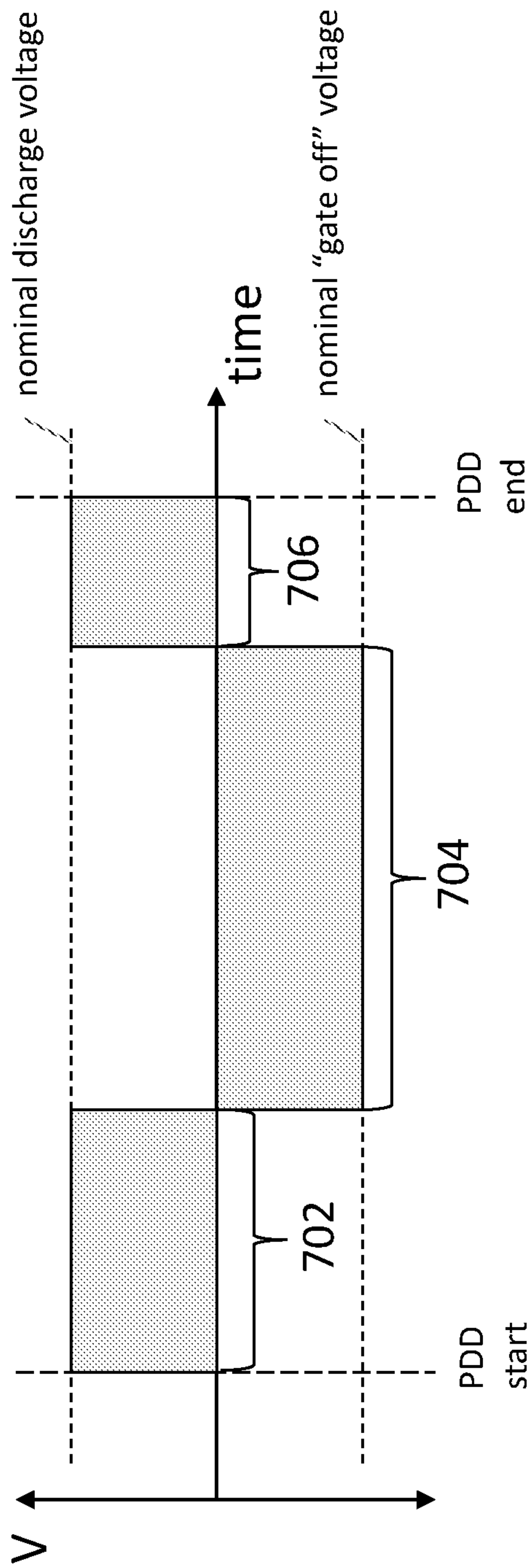

FIG. 7



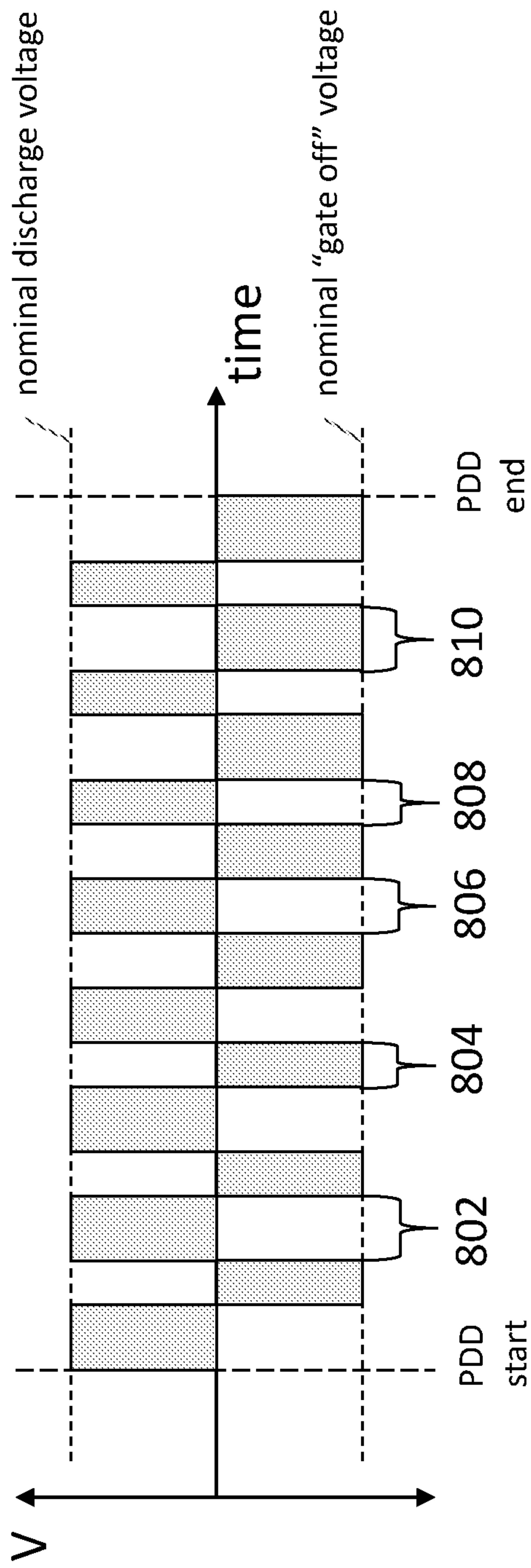

FIG. 8

**INTERNATIONAL SEARCH REPORT**

International application No.

**PCT/US2020/060835**

<b>A. CLASSIFICATION OF SUBJECT MATTER</b> <b>G09G 3/34(2006.01)i; G02F 1/167(2006.01)i</b>  According to International Patent Classification (IPC) or to both national classification and IPC		
<b>B. FIELDS SEARCHED</b>  Minimum documentation searched (classification system followed by classification symbols) G09G 3/34(2006.01); G06F 3/038(2006.01); G09G 3/38(2006.01); G09G 5/10(2006.01)  Documentation searched other than minimum documentation to the extent that such documents are included in the fields searched Korean utility models and applications for utility models Japanese utility models and applications for utility models  Electronic data base consulted during the international search (name of data base and, where practicable, search terms used) eKOMPASS(KIPO internal) & keywords: electro-optic display, pixel, transistor, remnant voltage, drain, stop		
<b>C. DOCUMENTS CONSIDERED TO BE RELEVANT</b>		
Category*	Citation of document, with indication, where appropriate, of the relevant passages	Relevant to claim No.
X	US 2017-0076672 A1 (E INK CORPORATION) 16 March 2017 (2017-03-16) paragraphs [0004], [0077]-[0082], [0121]; and figures 1B, 12A	1-20
A	US 2005-0212747 A1 (KARL R. AMUNDSON) 29 September 2005 (2005-09-29) paragraph [0063]; claim 1-17; and figure 3	1-20
A	US 2010-0091049 A1 (JUNG-WOO KIM) 15 April 2010 (2010-04-15) paragraphs [0057]-[0081]; and figures 3-5	1-20
A	US 2007-0146306 A1 (MARK THOMAS JOHNSON et al.) 28 June 2007 (2007-06-28) paragraph [0051]; and figure 6	1-20
A	KR 10-1296646 B1 (LG DISPLAY CO., LTD.) 14 August 2013 (2013-08-14) paragraphs [0043]-[0046]; and figures 3-4	1-20
<input type="checkbox"/> Further documents are listed in the continuation of Box C. <input checked="" type="checkbox"/> See patent family annex.		
* Special categories of cited documents: “A” document defining the general state of the art which is not considered to be of particular relevance “D” document cited by the applicant in the international application “E” earlier application or patent but published on or after the international filing date “L” document which may throw doubts on priority claim(s) or which is cited to establish the publication date of another citation or other special reason (as specified) “O” document referring to an oral disclosure, use, exhibition or other means “P” document published prior to the international filing date but later than the priority date claimed  “T” later document published after the international filing date or priority date and not in conflict with the application but cited to understand the principle or theory underlying the invention “X” document of particular relevance; the claimed invention cannot be considered novel or cannot be considered to involve an inventive step when the document is taken alone “Y” document of particular relevance; the claimed invention cannot be considered to involve an inventive step when the document is combined with one or more other such documents, such combination being obvious to a person skilled in the art “&” document member of the same patent family		
Date of the actual completion of the international search	Date of mailing of the international search report	
<b>04 March 2021</b>	<b>05 March 2021</b>	
Name and mailing address of the ISA/KR	Authorized officer	
<b>Korean Intellectual Property Office 189 Cheongsu-ro, Seo-gu, Daejeon 35208, Republic of Korea</b>	<b>YANG, Jeong Rok</b>	
Facsimile No. +82-42-481-8578	Telephone No. +82-42-481-5709	



**INTERNATIONAL SEARCH REPORT**  
**Information on patent family members**

International application No.

**PCT/US2020/060835**

Patent document cited in search report			Publication date (day/month/year)	Patent family member(s)			Publication date (day/month/year)				
US	2017-0076672	A1	16 March 2017	CN	108028034	A	11 May 2018				
				EP	3350798	A1	25 July 2018				
				EP	3350798	A4	05 June 2019				
				HK	1247729	A1	28 September 2018				
				JP	2018-529126	A	04 October 2018				
				KR	10-2018-0030949	A	26 March 2018				
				KR	10-2020-0110475	A	23 September 2020				
				KR	10-2158965	B1	23 September 2020				
				TW	201719616	A	01 June 2017				
				TW	I637377	B	01 October 2018				
				US	2020-0402469	A1	24 December 2020				
				WO	2017-049020	A1	23 March 2017				
				<hr/>							
				US	2005-0212747	A1	29 September 2005	EP	1743316	A2	17 January 2007
EP	1743316	A4	26 August 2009								
HK	1103840	A1	24 December 2009								
JP	2007-531009	A	01 November 2007								
JP	2011-076103	A	14 April 2011								
JP	2014-197229	A	16 October 2014								
JP	4740943	B2	03 August 2011								
JP	5873241	B2	01 March 2016								
KR	10-0831188	B1	21 May 2008								
KR	10-2006-0132742	A	21 December 2006								
TW	I374414	B	11 October 2012								
US	7492339	B2	17 February 2009								
WO	2005-101363	A2	27 October 2005								
WO	2005-101363	A3	06 July 2006								
<hr/>											
US	2010-0091049	A1	15 April 2010	CN	101726957	A	09 June 2010				
				CN	104991392	A	21 October 2015				
				CN	104991392	B	11 January 2019				
				EP	2178074	A1	21 April 2010				
				EP	2178074	B1	28 June 2017				
				JP	2010-097218	A	30 April 2010				
				JP	5611564	B2	22 October 2014				
				KR	10-1534191	B1	06 July 2015				
				KR	10-2010-0042019	A	23 April 2010				
				US	2014-0092149	A1	03 April 2014				
				US	8624834	B2	07 January 2014				
US	9311887	B2	12 April 2016								
<hr/>											
US	2007-0146306	A1	28 June 2007	AT	484817	T	15 October 2010				
				CN	1926601	A	07 March 2007				
				CN	1926601	B	17 November 2010				
				EP	1723630	A2	22 November 2006				
				EP	1723630	B1	13 October 2010				
				JP	2007-525719	A	06 September 2007				
				JP	4787981	B2	05 October 2011				
				KR	10-2007-0007298	A	15 January 2007				
				TW	200601238	A	01 January 2006				
				US	7800580	B2	21 September 2010				
				WO	2005-088603	A2	22 September 2005				
WO	2005-088603	A3	16 February 2006								

**INTERNATIONAL SEARCH REPORT**  
**Information on patent family members**

International application No.

**PCT/US2020/060835**

Patent document cited in search report	Publication date (day/month/year)	Patent family member(s)	Publication date (day/month/year)
KR 10-1296646 B1	14 August 2013	KR 10-2008-0090185 A	08 October 2008