



(51) International Patent Classification:

B64C 15/00 (2006.01) *B64C 27/52* (2006.01)
B64C 29/00 (2006.01) *B63H 5/10* (2006.01)
B64C 27/08 (2006.01)

(21) International Application Number:

PCT/US2013/033985

(22) International Filing Date:

27 March 2013 (27.03.2013)

(25) Filing Language:

English

(26) Publication Language:

English

(30) Priority Data:

13/442,544 9 April 2012 (09.04.2012) US

(72) Inventor; and

(71) Applicant : **SMITH, Frick, A.** [US/US]; 12735 West Fm 1431, Kingsland, TX 78639 (US).

(74) Agents: **ALLEN, Courtenay, B.** et al.; Cox Smith Matthews Incorporated, 112 East Pecan Street, Suite 1800, San Antonio, TX 78205 (US).

(81) Designated States (unless otherwise indicated, for every kind of national protection available): AE, AG, AL, AM, AO, AT, AU, AZ, BA, BB, BG, BH, BN, BR, BW, BY,

BZ, CA, CH, CL, CN, CO, CR, CU, CZ, DE, DK, DM, DO, DZ, EC, EE, EG, ES, FI, GB, GD, GE, GH, GM, GT, HN, HR, HU, ID, IL, IN, IS, JP, KE, KG, KM, KN, KP, KR, KZ, LA, LC, LK, LR, LS, LT, LU, LY, MA, MD, ME, MG, MK, MN, MW, MX, MY, MZ, NA, NG, NI, NO, NZ, OM, PA, PE, PG, PH, PL, PT, QA, RO, RS, RU, RW, SC, SD, SE, SG, SK, SL, SM, ST, SV, SY, TH, TJ, TM, TN, TR, TT, TZ, UA, UG, US, UZ, VC, VN, ZA, ZM, ZW.

(84) Designated States (unless otherwise indicated, for every kind of regional protection available): ARIPO (BW, GH, GM, KE, LR, LS, MW, MZ, NA, RW, SD, SL, SZ, TZ, UG, ZM, ZW), Eurasian (AM, AZ, BY, KG, KZ, RU, TJ, TM), European (AL, AT, BE, BG, CH, CY, CZ, DE, DK, EE, ES, FI, FR, GB, GR, HR, HU, IE, IS, IT, LT, LU, LV, MC, MK, MT, NL, NO, PL, PT, RO, RS, SE, SI, SK, SM, TR), OAPI (BF, BJ, CF, CG, CI, CM, GA, GN, GQ, GW, ML, MR, NE, SN, TD, TG).

Published:

- with international search report (Art. 21(3))
- before the expiration of the time limit for amending the claims and to be republished in the event of receipt of amendments (Rule 48.2(h))

(54) Title: AIRCRAFT WITH FREEWHEELING ENGINE

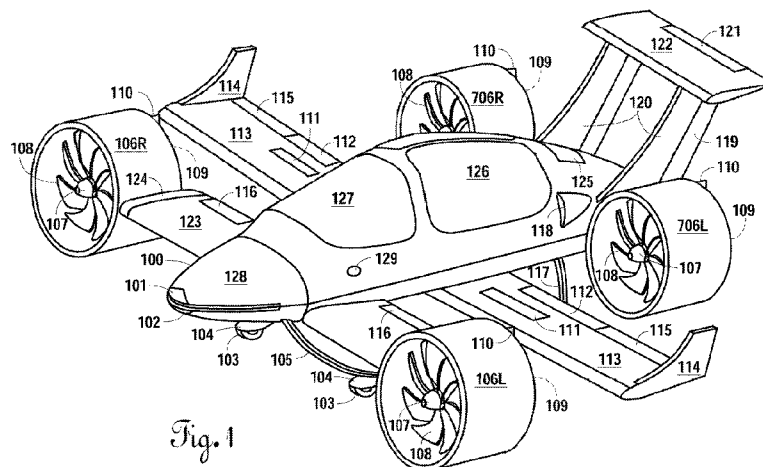

Fig. 1

(57) Abstract: An aircraft may have a fuselage, a left wing extending from the fuselage, a right wing extending from the fuselage, a tail section extending from a rear portion of the fuselage, and a first engine and a second engine operably connected by a common driveshaft, wherein the first and second engines are configured for freewheeling such that if one of the first and second engines loses power the other of the first and second engines continues to power the aircraft.



IN THE UNITED STATES RECEIVING OFFICE

PCT INTERNATIONAL PATENT APPLICATION

TITLE: AIRCRAFT WITH FREEWHEELING ENGINE

ATTORNEY DOCKET NO.: 33189.6

INVENTOR

NAME: FRICK A. SMITH

RESIDENCE: KINGSLAND, TEXAS, US

CITIZENSHIP: US

Title: AIRCRAFT WITH FREEWHEELING ENGINE

Inventor: Frick A. Smith

CROSS REFERENCE TO RELATED APPLICATIONS

[0001] This application claims priority to U.S. Patent Application No. 13/442,544 filed April 9, 2012, which is a continuation-in-part of U.S. Application No. 13/012,763 filed January 24, 2011, which is a continuation-in-part of U.S. Patent Application No. 11/581,321 filed October 16, 2006, which claims priority to U.S. Provisional Patent Application No. 60/727,798 filed October 18, 2005, the disclosures of each of which are incorporated herein by reference.

FIELD

[0002] This invention relates generally to Vertical Take-Off and Landing (VTOL) aircraft and more specifically to a compact VTOL aircraft with a fixed wing which can be utilized as a Personal Air Vehicle (PAV) or an Unmanned Aerial Vehicle (UAV).

BACKGROUND

[0003] Inventors have long contemplated and attempted to design vehicles which would serve as a combination car/airplane. That creation could be driven as a car to an airport where it would be converted with wings and then flown like an airplane. Upon landing, the aircraft would be converted back to a car and then driven on a roadway to a destination. The Aerocar (1959) by Molt Taylor and the recent "Transition" flying car by Massachusetts Institute of Technology graduate student Carl Dietrich and the MIT team show a continuation of that dream. However, that dream has not been fully realized, and a need still remains for an aircraft that may operate without being constrained to airports or roadways.

SUMMARY

[0004] The present disclosure is directed to an aircraft that contemplates no need for driving a car through traffic to and from airports. The capabilities and properties of this particular aircraft make it compact and versatile enough so as to enable a pilot to fly this aircraft from “door to door” without the requirement of an airport or highways. For example, a person could lift off as with a helicopter from a space such as a driveway, back yard, parking garage, rooftop, helipad, or airport and then fly rather than drive to all the day’s various appointments. Some embodiments of the present invention provide a versatile VTOL aircraft that is not only lightweight and powerful enough to take off and land vertically, but is also economical and powerful enough to take off, land and fly at a fast rate of speed, like an airplane. Therefore, it serves as a personal air vehicle (PAV) with a multitude of uses and configurations. The ability to transition from vertical flight to forward flight and back again provides unlimited possibilities because it combines the flexibility and best attributes of both types of aircraft.

[0005] In some embodiments, the current invention is able to achieve its power from the placement and production of two (2) Axial Vector/Dyna-Cam type engines mounted sideways with respect to the fuselage of the aircraft (that is, the axis of rotation of the driveshaft of each engine may be oriented transverse to the longitudinal axis of the fuselage). These engines are lightweight and produce greater horsepower and three (3) times more torque per horsepower than conventional engines. Each engine may have a double-ended driveshaft which provides direct drive to the ducted fans/nacelles which are located outside of the fuselage. Each end of each double-ended driveshaft may turn one ducted fan, so two engines will power two (2) pairs of ducted fans for a total of four ducted fans.

Forward Engine

[0006] In some embodiments, a first engine may be placed in the front section of the aircraft fuselage, and the driveshafts from the ends of the first engine may run through a front canard wing on the aircraft to a front pair of ducted fans located at the ends of the canard wing. These front ducted fans may be mounted far enough out from the fuselage to prevent propeller wash in the rear ducted fans.

Rear Engine

[0007] In some embodiments, a second engine may be mounted behind the passenger cabin and toward the rear of the fuselage. This engine may power an aft pair of ducted fans which are attached to the fuselage, so the driveshaft for this engine may connect directly through a transfer case to differentials in the ducted fans. The rear engine may be slightly elevated above the center line of the side of the fuselage.

In-line Configuration

[0008] The two sideways mounted engines may be placed in-line in the fuselage so the passenger cabin and the rear engine receive less wind resistance, thus reducing drag on the airplane and increasing fuel efficiency. As early as 1937, Dr. Claude Dornier used the in-line configuration in his German built Dornier DO335. By the 1960s, the Cessna Skymaster 336 was using in-line engines, and presently the Adams A500 designed by Burt Rutan is utilizing the configuration. Since the engines are located inside the fuselage rather than outside in the ducted fans or at the end of a main wing, as on the Bell Boeing V-22 Osprey, a better in-line center of gravity is established thereby resulting in quicker response, better balance and increased stability in flight and/or in hover.

Ducted Fans

[0009] In some embodiments, the aircraft may have a fixed wing and four aerodynamically designed tilt ducted fans. As early as the 1960s, the Bell X-22A was one of

the first aircraft to fly using tilt ducted fans. More recently, Moller's "Skycar" (U.S. Pat. No. 5115996) is a vehicle which includes ducted fans with directional vanes and two engines in each duct for a total of eight engines. Unlike the X-22 with its four engines and Moeller's car with its eight engines, some embodiments of this invention use only two sideways placed engines in the fuselage with direct drive from the driveshafts into differentials in the ducted fans to power four ducted fans, with no intervening transmission between the rotor of each engine and the driveshaft or between the driveshaft and the differentials. The elimination of a transmission in such a direct drive embodiment saves weight and increases efficiency and performance.

[0010] The fact that only a differential rather than a motor is located in the ducted fans of some embodiments of this invention creates a larger volume of airflow through the ducted fans. Eliminating the weight of the motors or engines outboard of the fuselage also reduces the weight on the side of the fuselage and/or the wing tips, thereby using less horsepower and torque and in turn making the aircraft more responsive and stable.

[0011] Most ducted fans have a problem when reaching higher speeds because of a tendency to push air out in front of the duct. In some embodiments of the current invention, the aerodynamic shape of the front of the ducted fans is such that the bottom of each duct protrudes forward and the top of each duct slopes down to the bottom. This lifting air intake duct design creates low pressure in the bottom front of the duct which helps eliminate the need for more wing area and in turn reduces the weight of the aircraft. Willard Custer illustrated this lift principle with his Channelwing aircraft in the late 1930s. This technology is being researched even today at the Georgia Institute of Technology.

[0012] Another result of extending the bottom of the ducts is a reduction of the noise created by the turning blades. In a UAV stealth design, this will also help cover the radar signature from the turning blades.

[0013] In some embodiments, ducted fans permit the aircraft to take off and land in either conventional or VTOL mode. Since the fan blades may be encased in ducts, the ducts can be rotated to align horizontally with the fuselage, and the aircraft may take off and land conventionally. In some embodiments, such ducted fans may provide greater flexibility in terms of sizing, thrust, and ground clearance than if unducted propellers are used. In some embodiments, a double row of counter-rotating fan blades in the ducted fans may provide sufficient thrust so that the duct diameter may be small enough for sufficient ground clearance. In some embodiments, conventional take-off and landing may also be provided because the double row of counter-rotating blades in the ducted fans allow the ducted fans to be small enough to clear the ground when oriented horizontally. In some embodiments, VTOL is possible because the ducted fans may rotate to a vertical orientation and provide sufficient thrust for take-off and landing.

Lifting body Airframe

[0014] In some embodiments, the aircraft body itself may be an aerodynamically designed lifting body. As far back as the 1920s, Burnelli Aircraft was building a lifting body airframe (U.S. Pat. 1758498). Today, the Space Shuttle still utilizes that technology. With the engines mounted sideways with respect to the fuselage, this design lends itself to a lifting body application.

Emergency Parachute

[0015] Some embodiments of the current invention include a power boosted emergency parachute assembly which can be used in hover or flight conditions, should the aircraft lose one or more of its engines, thus allowing the pilot to continue to maneuver the aircraft to a safe landing.

Fly-by-Wire Control System

[0016] Some embodiments of the current invention incorporate a computer controlled fly-by-wire system which calculates gyroscopic stability and sends information to one or more ducted fans or propeller blades to adjust them to the correct pitch for controlled flight.

Fixed Wing with Removable Sections

[0017] In some embodiments, the aircraft may have a fixed level, dihedral, or anhedral wing to provide for forward flight in airplane mode. Sections of the aircraft wings may be bolted on or removed to create various wing lengths for different applications, such as for short distances as in a city setting or long distances for long range travel and for easy transporting of the aircraft, as on a trailer or truck or in a shipping container. For example, extensions on the main wing may enable an aircraft to fly at high altitude and/or to loiter for long periods of time.

[0018] By combining the attributes of a fixed wing airplane and a helicopter to a lightweight and compact aircraft, a personal air vehicle may become a new mode of transportation. The embodiments set forth herein are merely examples of various configurations of the aircraft, and many new models can result from this invention. Different embodiments of this aircraft could range from a variety and number of passenger seating arrangements to a model with no passengers; i.e., a UAV. In other applications, the aircraft may serve as a personal air vehicle, an air taxi, an observation aircraft, an emergency rescue vehicle, a military vehicle or a UAV, or for other purposes.

[0019] Some embodiments may be constructed of lightweight material and the airframe may be designed as a lifting body, which helps reduce the weight and the square footage area of the wings.

[0020] Some embodiments may have the vertical take-off, landing and flight capabilities of a helicopter and the conventional take-off, landing and flight capabilities of an

airplane. Some embodiments may transition back and forth between VTOL and forward flight. If the aircraft is in hover position, air deflectors (which may be mounted on the rear of each ducted fan) may enable the aircraft to move sideways and to counter rotate, and the tilted ducted fans may enable it to move forward and backward safely in tight spaces. Since some embodiments of the aircraft may use significant power to accommodate its VTOL capabilities, the aircraft may also be designed to take advantage of this power and transform it into maximum airspeed in forward flight.

[0021] All these capabilities make this a truly unique aircraft, capable of a multitude of uses. Some embodiments of the current invention can lift off and set down like a helicopter, but can also utilize the speed of an airplane to provide quick “door to door” service for convenience and for the saving of time and fuel.

[0022] Since some embodiments of the aircraft can take off like an airplane, it may be capable of handling more weight—such as that of passengers, fuel and freight—on takeoff and then traveling a longer distance. In some embodiments, the aircraft may land in a conventional aircraft mode on a runway, if desired, or the aircraft may land vertically in a smaller space or without a runway. In some embodiments, the compact nature of the aircraft, combined with the use of ducted fans, may provide a large spectrum of landing locations for it as a VTOL vehicle.

[0023] Although some embodiments of the aircraft may not be as fast as the new light jets currently being developed and soon to be offered for air taxi service, the aircraft nonetheless saves overall time because it can take off and land in locations other than a landing strip. Time commuting to and from an airport can be significant, and some embodiments of this aircraft may provide a means to bypass airports by leaving from and returning to a nearby convenient location.

[0024] In some embodiments, one advantage of the fixed wing aircraft is the ability to throttle back the engines and use lift from the wing to help the engines conserve fuel while flying. In some dual engine embodiments, either engine may be shut off, and the aircraft can cruise on one engine for improved fuel economy. For example, Burt Rutan's Voyager took off using both engines, then shut down one engine and flew around the world—using one engine—without refueling. Additionally, the wing may be dihedral, which may improve the stability of the aircraft.

[0025] In some dual engine embodiments, if one engine is lost, the aircraft can fly on either of its engines and continue to an airport to land conventionally. If both engines are lost while in flight, the aircraft's glide slope is excellent. The pilot can glide the aircraft to a landing site or use a guidable emergency parachute to float to a safe location.

[0026] In some embodiments, another advantage derives from the fact that the engines are not in the ducts but are instead mounted in the fuselage, providing an in-line center of gravity for better stability and increased response (as opposed to having the weight of the engines on the wingtips). Additionally, the front engine may break the air for both the cabin and the rear engine, thus creating a very aerodynamic lifting body aircraft.

[0027] In some embodiments, the elevation of the rear engine may allow for air intake scoops to be mounted on the front of each side of the engine, thereby providing for air cooling of the rear engine while still maintaining the aircraft's aerodynamic design. In conventional airplane mode, this elevation may also improve the flare of the aircraft upon landing and derotation and may allow the rear landing gears to hit the runway first. It also may improve take-off and rotation because the front landing gear of the aircraft may lift off first.

[0028] In some embodiments, another advantage in landing an aircraft as described herein is that, in the case of an engine being lost, the two ducted fans attached to that engine

may stop also. Consequently, the critical engine problem which causes yaw and then roll, usually experienced when a twin engine aircraft loses an engine, may be eliminated. Additionally, if an engine is lost, some embodiments of the aircraft are capable of auto feathering the fan blades of the two ducted fans associated with that engine, thereby reducing drag through the duct.

[0029] In some embodiments, the sideways placement of the engines may provide the ability to power two ducted fans with one engine having a double-ended driveshaft. In such embodiments, the cost of construction and operation of the aircraft may be less, for example, because only two engines may be used to power four ducted fans.

[0030] In some embodiments, one or more driveshafts of the rear engine may be shortened going into the associated rear ducted fans because the ducted fans may be mounted on the side of the fuselage, and one or more driveshafts of the front engine may be shortened going through a canard wing which may not be as long as a main wing. This configuration not only may reduce the weight of the one or more driveshafts, but may also provide an enhanced safety factor. Since a driveshaft may enter the middle of a differential in a ducted fan, the driveshaft may naturally turn two output shafts of the ducted fan in a counter rotating motion. This reliable yet simple design may also add to the safety of the aircraft.

[0031] In some embodiments, the aircraft may use an Axial Vector/Dyna-Cam type engine which may provide many advantages, including very smooth operation with little vibration and utilization of a variety of fuels and high fuel efficiency. The Axial Vector/Dyna-Cam type engine is a lightweight, small and compact internal combustion engine with high horsepower and high torque. A high torque engine may allow a high angle of attack on variable pitch blades, which may provide quick response with little variation in the rpm of the engine.

[0032] In some embodiments, the ducts of the ducted fans may be aerodynamically designed to create lift thereby reducing the weight of the aircraft because of less square footage of wing area than otherwise may be required. Since no engines are located in the ducts, more area is available for airflow through the ducts, thus creating more lift and thrust. In some embodiments, the front pair of ducts may be mounted far enough out on the canard wing to allow the rear ducts to receive undisturbed air.

[0033] In some embodiments, two rows of blades in a ducted fan may turn in a counter rotating motion thereby creating more thrust and reducing the overall diameter of the duct. This reduced diameter may provide sufficient ground clearance for a conventional aircraft take-off and landing mode as well as VTOL and VSTOL capability.

[0034] Tilt ducted fans may provide the ability to get full thrust on lift and forward flight. The aerodynamic shape of the lifting duct may provide for more lift with less weight since a shorter wing may be used.

[0035] In some embodiments, the blades in each row of a ducted fan may have variable pitch. The pitch angle of the blades may be determined and controlled by a computer in communication with gyros in a fly-by-wire system, thus controlling pitch for stability in a hover mode or adjusting pitch while in forward flight. The blades may have the capability of self feathering and lining up in an identical configuration behind one another within each duct to help reduce drag and increase air flow through the ducts should an engine be lost or shut down. This capability may extend the range which can be flown with one engine.

[0036] In some embodiments, the use of ducted fans instead of un-ducted propellers may provide for safer VTOL. In such embodiments, no exposed propellers are involved, so the aircraft can land in tight spaces or get close to people or to stationary objects. For example, it could hover next to buildings for rescues, land in fields with electrical wires,

and/or land in neighborhoods or a regular parking lot. In such embodiments, since ducts surround the fan blades, the ducted fans may be quieter, enabling the aircraft to take off and land with less noise than is typically associated with helicopters. This ducted fan design may also help reduce or cover the radar signature from the turning blades in a UAV stealth design.

[0037] NASA has been researching and developing its “highway in the sky” which provides synthetic vision and GPS guidance in aircraft so that pilots can bypass the large congested airport hubs and land at smaller airports. That technology may be included in some embodiments of this invention, which may allow pilots to bypass even the small airports and land at or near their actual destinations, and it may assist in handling bad weather such as fog.

[0038] Some embodiments of this invention may include an emergency parachute system that provides for quick deployment and rapid expansion to prevent significant altitude loss while in hover or for a delayed deployment while in forward flight. Most of the currently used emergency parachutes—often referred to as whole-airplane recovery parachute systems—require too much time to fill with air, resulting in a significant loss of altitude before the parachute can take effect.

[0039] The Ballistic Recovery System (BRS) which was invented and patented by Boris Popov (U.S. Pat. No. 4607814) was originally created for ultralights and experimental aircraft and later retrofitted for larger aircraft. The BRS system is currently utilized by Cirrus Design for its lighter single engine airplanes. However, the emergency parachute system in the Cirrus aircraft allows a significant loss of altitude before the canopy is filled with air. Once the Cirrus is descending under the parachute, the pilot has no control of the descent and therefore no control of the landing site. The rocketed parachute system in some embodiments of the present invention may rapidly deploy and expand the parachute and then allow the pilot to steer the parachute to get the aircraft to a preferred landing site.

[0040] A sport plane embodiment of this aircraft may have a fuselage having a longitudinal axis, a left wing extending from the fuselage, a right wing extending from the fuselage, a tail section extending from a rear portion of the fuselage, a first ducted fan rotatably mounted to the left wing, a second ducted fan rotatably mounted to the right wing, and an engine disposed in the fuselage, the engine having a direct-drive, double-ended driveshaft having an axis of rotation oriented transverse to the longitudinal axis of the fuselage, wherein the first ducted fan includes a first differential operably connected between first and second rows of counter rotating fan blades, wherein the second ducted fan includes a second differential operably connected between third and fourth rows of counter rotating fan blades, and wherein one end of the driveshaft is directly connected to the first differential, and the other end of the driveshaft is directly connected to the second differential.

BRIEF DESCRIPTION OF THE DRAWINGS

[0041] FIGURE 1 is a front perspective view of a four ducted fan aircraft embodiment of the current invention.

[0042] FIGURE 2a is a top schematic cross-sectional view of the aircraft of FIG. 1 showing single engines serving the front and rear pairs of ducted fans.

[0043] FIGURE 2b is a top schematic cross-sectional view of the aircraft of FIG. 1 showing pairs of engines serving the front and rear pairs of ducted fans.

[0044] FIGURE 3a is a side schematic cross-sectional view of a ducted fan assembly.

[0045] FIGURE 3b is a top schematic cross-sectional view of the ducted fan assembly of FIG. 3a.

[0046] FIGURE 3c is a front view of the ducted fan assembly of FIG. 3a.

[0047] FIGURE 4a is a side view of the aircraft of FIG. 1 in forward flight with rear thrust.

[0048] FIGURE 4b is a side view of the aircraft of FIG. 1 in hover with downward thrust.

[0049] FIGURE 4c is a side view of the aircraft of FIG. 1 in braking position with reverse thrust.

[0050] FIGURE 5 is a front perspective view of a Personal Air Vehicle (PAV) or an Unmanned Aerial Vehicle (UAV) embodiment.

[0051] FIGURE 6 is a front perspective view of a Sport Plane embodiment.

DETAILED DESCRIPTION

[0052] As used herein, the following terms should be understood to have the indicated meanings:

[0053] When an item is introduced by “a” or “an,” it should be understood to mean one or more of that item.

[0054] “Comprises” means includes but is not limited to.

[0055] “Comprising” means including but not limited to.

[0056] “Having” means including but not limited to.

[0057] “Including” means including but not limited to.

VTOL aircraft with sideways mounted engines

[0058] As shown in FIGS. 1 and 2a, a first embodiment of the current invention may have four ducted fans. This embodiment is a VTOL aircraft with two (2) engines—one fore **201** and one aft **202**—placed sideways with respect to an elongated lifting body fuselage **100**, which may be made of lightweight composite materials, aluminum, or other suitable materials. This embodiment may have a canard wing **123** on the front, a fixed main wing **113** in the middle of the fuselage **100** with winglets **114** attached on each end of the main wing **113**, two vertical stabilizers **120** on the rear, a horizontal stabilizer **122** across the top of the tail, a pair of ducted fans **106R** and **106L** fore, and a pair of ducted fans **706R** and **706L** aft

on each side of the fuselage **100** for a total of four (4) ducted fans. The canard wing **123** and the main wing **113** may be level, dihedral, or anhedral, depending on the overall aerodynamic design of the aircraft. In this example, all four ducted fans may have the same design and are sometimes referred to as element **106** in the discussion of this embodiment. Alternatively, the ducted fans may not all have the same design. In other alternative embodiments, un-ducted propellers may be used instead of ducted fans, or a combination of ducted fans and un-ducted propellers may be used.

[0059] The engines **201**, **202** may be Axial Vector/Dyna-Cam type engines or other suitable engines. The Axial Vector engine from Axial Vector Engine Corporation is a six piston twelve cylinder radial design with high horsepower and torque. The engine is small, lightweight and produces three times the torque per horsepower as compared to some other available engines, thus improving the power-to-weight ratio. It is fuel efficient and can use a variety of fuels. It has fewer parts and produces less vibration than some other available engines.

Passenger Cabin

[0060] In this example, the passenger cabin may have a lightweight frame made of composite, aluminum, or other suitable material with one stationary front wraparound transparent canopy **127** which serves as the windshield, and two pivotally hinged gull wing style doors **126** which are wraparound door frames with transparent window material encompassing most of the surface to serve as the side windows and skylights on each side of the fuselage **100**. The doors **126** may also be made of composite, aluminum, or other suitable material. To clarify, these doors **126**, when closed, may serve as skylights on the top and windows on the side. The pilot and front passenger side of the cabin may have transparent material of oval or other suitable shape in the floorboard which may provide for downward viewing and may also provide an emergency escape hatch. The side door **126** may pivot

wide open to allow for loading/unloading of large loads; e.g., an emergency stretcher or large cargo. It may open large enough to accommodate the ingress and egress of both the front and rear passengers. Some embodiments of the present invention may have a four-seat cabin, but other embodiments may include fewer or more than four seats, and still other embodiments may be utilized as an unmanned aerial vehicle (UAV) with no seats.

Forward Section of the Aircraft

[0061] The headlights/landing lights encasement **101** may have a streamlined transparent protective covering located on the nose of the fuselage **100** and one front air intake **102** may be located on each side of the nose of the fuselage **100**. A canard wing **123** may be attached to the front fuselage **100**, with a ducted fan **106** attached to each end of the canard wing by a duct rotation actuator **124**. Elevators **116** on the trailing edge of the canard wing may facilitate in controlling the pitch of the aircraft.

[0062] Each of the ducted fans **106** may house a front blade actuator assembly **107** which controls the pitch angle of a front row of blades **108** and a rear blade actuator assembly **210** which controls the pitch angle of a rear row of counter rotating blades **109** (hidden in FIG. 1; see FIGS. 2a, 2b, 3a, 3b). A duct air deflector **110** may be located on the rear of each ducted fan **106**. Each of the four ducted fans **106** on the aircraft may contain the same front and rear blade assemblies and configuration, and each may or may not have a duct air deflector **110** on the rear of the ducted fan **110**. Alternatively, the ducted fans **106** may not all be of the same design. For example, in some embodiments, the forward ducted fans **106** may be of one design, and the rear ducted fans **106** may be of a different design. The air deflector **110** may facilitate control of the transition from forward flight to hover and back to forward flight or from hover to forward flight and back to hover, and control of the sideways and counter rotating motion when in hover.

[0063] One front tire **103** may be located on the front bottom of each side of the fuselage and may be attached to a fixed front landing gear spar **105** and may be partially covered by a streamlined fairing **104** which is wrapped around each tire **103**. Alternatively, the tires **103** and associated landing gear may be retractable into the fuselage **100** or the canard wing **123**. The spars **105** may be fixed, and the tires **103** may be pivoting to provide a tight turning radius. A first avionics bay **128** for storing the aircraft's computer, gyroscopic equipment, etc. may be located inside the nose cone. This avionics bay **128** may house the flight computers and gyroscopes which handle guidance, navigation and control; for example, it may serve as a data bus which takes the flight instrumentation, weather and additional data, along with pilot input, to control flight. A second bay may be located in the back (not shown) for redundancy.

Center of the Aircraft

[0064] The main wing **113** may be attached to the bottom of the fuselage **100** below the passenger cabin doors **126**. Alternatively, the main wing **113** may be attached to the top of the fuselage **100** or to some intermediate portion of the fuselage **100**. A speed brake **111** may be located toward the center of the wing **113** on each side of the fuselage to enable the aircraft to slow while in forward flight. The wing **113** may include winglets **114** to help reduce drag and thereby increase speed and lift; ailerons **115** to help control roll while in forward flight; and flaps **112** to help reduce landing speed, move into transitional speed while switching from horizontal to vertical and/or back to horizontal flight, and decrease the surface area of the wing thus resulting in less drag on vertical take-off. In some embodiments, other control surfaces may be employed in combination with or in lieu of speed brakes **111**, ailerons **115**, and flaps **112**.

Rear Section of the Aircraft

[0065] One rear tire (not shown in FIGURE 1) may be attached to a fixed or retractable rear landing gear spar **117** on each side of the fuselage **100** toward the aft section of the aircraft. Each of these rear tires may be fixed and covered by a streamlined fairing **104** or retractable into the aft portion of the fuselage **100** and may be equipped with brakes.

[0066] A ducted fan **106** may be located on each side of the fuselage **100** with the attachment point located behind the rear passenger cabin/canopy **126**.

[0067] The rear engine **202** may be mounted slightly higher than the front engine **201** to provide room for air intake cooling which may be accomplished through an air intake scoop **118** located behind the passenger cabin/canopy **126** and on each side of the fuselage **100**.

[0068] One fixed vertical stabilizer **120** may be attached on each side and at the end of the fuselage **100** to minimize or eliminate the yaw/roll oscillations and to reduce the drag off the aft end of the lifting body fuselage **100**. A rudder assembly **119** attached to the rear of each vertical stabilizer **120** may help provide yaw control. Atop the vertical stabilizers **120**, a horizontal stabilizer **122** may be attached, with a rear elevator **121** located on the trailing edge of the horizontal stabilizer **122** for pitch control.

[0069] An emergency parachute with deployment rocket launchers may be stored in a storage location compartment **125** in the rear fuselage **100**, just behind the passenger cabin/canopy **126** and above the rear engine **202**. The parachute cables may be attached to the aircraft at four attachment points **129** (three not shown). Two of these attachment points **129** may be located on each side of the aircraft, with two fore and two aft. The front parachute cable on each side may be routed from the attachment point **129** on the front of the aircraft, up the side of the fuselage **100** between the front canopy **127** and rear canopy **126**, across the top of the fuselage **100** between the left and right hinged gull wing doors **126**, and

back to the parachute storage compartment **125**. The rear attachment points **129** may be located behind and above the air intake scoop **118** on each side of the aircraft. The rear parachute cable on each side may be routed up the side of the aircraft from the attachment point **129** to the storage compartment **125**. All the parachute cable routings may be concealed in a recessed channel under a non-protruding breakaway covering (not shown) which is aerodynamically flush with the fuselage **100**.

[0070] As shown in FIGURE 2a, two double-ended, direct driveshaft engines **201**, **202** may be mounted longitudinally in-line with one another in the fuselage **100**, with one fore and one aft. Engines **201** and **202** may be oriented “sideways” with respect to the fuselage **100** such that the axis of rotation of the driveshaft **204** and **219**, respectively, of each engine is oriented transverse to the longitudinal axis of the fuselage. A first engine **201** may be placed sideways in the front portion of and with respect to the fuselage **100**, and a second engine **202** may be placed sideways in the rear portion of and with respect to the fuselage **100**. Each engine **201**, **202** may have a double-ended driveshaft **204** or **219**, respectively, which powers a pair of ducted fans **106R** and **106L** forward, and **706R** and **706L** aft. One ducted fan **106R**, **106L** may be mounted on each end of the front canard wing **123**, and one ducted fan **706R**, **706L** may be mounted on each side of the fuselage **100** behind the passenger cabin/canopy **126**.

[0071] In general, this embodiment of the current invention includes a first power generation device or engine **201** forward in the fuselage, which is used to power a first driveshaft that serves a ducted fan or propeller on the right canard wing and to power a second driveshaft that serves another ducted fan or propeller on the left canard wing. In some embodiments, the first power generation device may be a single engine, and the first driveshaft and the second driveshaft may be a single continuous driveshaft **226** that goes through the engine and protrudes out each end of the engine. In other embodiments described

below, the first power generation device may be two or more engines in alignment, and the first and second driveshafts may be a single continuous driveshaft or may be separate distinct driveshafts, which may be coupled together to act as a single driveshaft. The same is true for the rear power generation device or engine **202** and its associated driveshaft(s).

Forward Engine

[0072] The front engine **201** may be mounted in a sideways position with respect to the fuselage **100** between the nose of the aircraft and the front section of the cabin/canopy **127**. As the double-ended direct driveshaft **204** exits each end of the front engine **201**, each side of the driveshaft **204** runs in an opposite direction and exits the fuselage **100** through a transfer case **203**, continues span-wise through the canard wing **123** and duct rotator actuator **124**, and connects to an internal duct differential **212** in a mid portion of the ducted fans **106L** and **106R**. The portion of the driveshaft **204** that exits the left end of the engine **201** runs to the left to power the left front ducted fan **106L**; the section of the driveshaft **204** that exits the right end of the engine **201** runs to the right to power the right front ducted fan **106R**.

Rear Engine

[0073] The rear engine **202** may be mounted in a sideways position with respect to the fuselage **100** behind the passenger cabin/canopy **126**. Rear engine **202** may be located in-line with the front engine **201** and may be slightly elevated above the center line of the fuselage **100**. Two air intake scoops **118**, with one mounted on each side of the fuselage in front of the rear engine **202**, may provide for air cooling of the rear engine **202**. The rear direct driveshaft **219** may be shorter than the front driveshaft **204** because the rear ducted fans **706L** and **706R** may be mounted on each side of the fuselage **100** just behind the passenger cabin/canopy **126**. Similar to the front engine **201**, the double-ended direct driveshaft **219** exits each end of the rear engine **202**, and each side of the driveshaft **219** runs in an opposite direction and exits the fuselage **100** through a transfer case **218**, continues

through a duct rotator actuator **124**, and connects to an internal duct differential **212** in a mid portion of the ducted fans **706L** and **706R**.

[0074] In this embodiment, the front transfer case **203** and the rear transfer case **218** may be connected by a transfer case supplemental driveshaft **217** which runs just inside of each side of the fuselage **100** between the transfer cases **203** and **218**. These supplemental driveshafts **217** are not normally engaged; however, should one engine lose power (sometimes referred to herein as a “dead,” “lost,” or “non-working” engine), a computer or other controller may engage the supplemental driveshafts **217** in the transfer cases **203**, **218** thereby bypassing the non-working engine. Through the transfer cases **203**, **218** and supplemental driveshafts **217**, the working engine may provide power to operate the pair of ducted fans **106R** and **106L**, or **706R** and **706L**, as the case may be, of the non-working engine and thus keep the aircraft in a stable position.

[0075] The mechanics inside each of the ducted fans **106R** and **106L** may be identical except for the entry of the driveshaft **204** through the duct rotator actuator **124** into the duct. The front **204** and rear **219** driveshafts extending from the right sides of the engines **201**, **202** enter the right front and right rear ducted fans **106R** and **706R** from the left; and the front **204** and rear **219** driveshafts running from the left sides of the engines **201**, **202** enter the left front and left rear ducted fans **106L** and **706L** from the right.

[0076] In each of the four ducted fans **106**, a differential casing **213** may house the differential **212** and two differential output driveshafts **225**. The differential **212** may turn the two differential output driveshafts **225** in a counter rotating motion with one shaft powering a row of variable pitch blades **108** at a front low pressure air intake opening **206** and one powering another row of variable pitch blades **109** at a rear air output expansion chamber **216** of each ducted fan **106**. These blades **108**, **109** may turn in a counter rotating motion with two computer controlled actuator assemblies—one front **107** and one rear **210**—determining

the pitch of the blades. As the actuator assembly **107, 210** increases the pitch of the blades **108, 109** in each of the ducted fans **106**, air flow is increased through the front air intake **206**, is compressed in the high pressure chamber **306**, and is exhausted by the rear row of blades **109** through the expansion chamber **216**. This creates the thrust for takeoff in either vertical or forward flight. FIGURES 3a, 3b, and 3c show enlarged illustrations of the ducted fans **106**, and FIGURES 4a, 4b, and 4c illustrate various rotational positions of the ducted fans **106** and how they affect take-off, flight, hover, and braking.

[0077] As shown in FIGURES 3a, 3b and 3c, each of the ducted fans **106** is a ducted tilt rotor, which may be composed of a lightweight composite, aluminum, or other suitable material. The rows of blades **108, 109** inside the ducts may be driven by a direct driveshaft **315** from a double-ended engine **201, 202** which is mounted sideways with respect to the aircraft fuselage **100** as described above. Referring also to FIGURES 2a and 2b, driveshaft **315** may be located in either the front of the aircraft as shown by element **204** or in the rear of the aircraft as shown by element **219**. The driveshaft **315** may enter each ducted fan **106** from the side and connect inside the differential casing **213** with the differential **212** in a mid portion of the ducted fan **106**. Extending from the differential **212**, a forward output shaft **307** and a rear output shaft **310** may respectively drive a forward row of fan blades **108** in a front portion of each ducted fan **106** and a rear row of fan blades **109** in a rear portion of each ducted fan **106**. The fan blades **108, 109** may turn in a counter rotating motion which may create more thrust and reduce the overall diameter of the ducted fans **106**, thereby providing sufficient ground clearance for conventional aircraft take-off and landing mode as well as VTOL capability.

[0078] FIGURE 3a and FIGURE 3b illustrate the aerodynamic shape of the front of each of the ducted fans **106**, with the bottom of each ducted fan **106** protruding forward as a lower front induction scoop **301** and with the top of each ducted fan **106** sloping down from

an upper front induction scoop **302** to the lower front induction scoop **301**, thereby creating more lift and less drag. This lifting air intake duct design may create a low pressure area **206** in the bottom front of the duct which in turn creates lift. This design may reduce or eliminate the need for more wing area and in turn may reduce the weight of the aircraft.

[0079] FIGURE 3a also shows a high pressure inner compression chamber **306** located between the two rows of rotating fan blades—front **108** and rear **109**--in each ducted fan **106**. The front blade actuator **107** changes the pitch of the front blades **108**. By increasing the pitch of the front row of blades **108**, air is pulled in and compressed in the high pressure inner compression chamber **306**. The rear blade actuator **210** changes the pitch of the rear row of blades **109**. The rear blades **109** pull the air from the high pressure inner compression chamber **306** and exhaust the air through the low pressure expansion chamber **216** thereby creating forward thrust.

[0080] The blades in each row may have variable pitch controlled by fly-by-wire computers which relay information to the front blade actuator **107** and to the rear blade actuator **210** to adjust the angle of the blades. Gyros located in the avionics bays may send a computer signal to the blade actuators **107**, **210** to help control the stability of the aircraft in hover. The blades may be capable of self feathering and lining up in an identical configuration behind one another within each ducted fan **106** to help reduce drag and to increase air flow through the ducts, should an engine be lost or shut down. This feathering feature may extend the range which can be flown with one engine.

[0081] Each ducted fan **106** may also have a rear air deflector **110** mounted vertically, horizontally, or in another desired configuration on the rear of the ducted fan **106** when positioned for forward flight or other flight condition. This deflector **110** may be controlled by a fly-by-wire actuator **300** and may divert air to the left, right, or other desired direction to help stabilize the aircraft when it transitions from flight to hover or undergoes another desired

maneuver. While in hover mode, the deflector **110** may divert the air to provide the ducted fans **106** with the capability of moving the aircraft sideways. Additionally, the air deflector **110** on the rear of the front ducted fans **106** may move one way while the air deflector **110** on the back of the rear ducted fans **106** may divert in the opposite direction or another desired direction, thus giving the aircraft counter-rotation capabilities.

[0082] FIGURES 4a, 4b and 4c show the position of the ducted fans **106** in forward flight, hover, and reverse, respectively.

[0083] FIGURE 4a shows the position of the ducted fans **106** for forward flight and for take-off in conventional fixed wing mode.

[0084] FIGURE 4b illustrates the position of the ducted fans **106** in hover and for vertical take-off. As the aircraft is lifting vertically as shown in FIGURE 4b, forward movement may be accomplished by a computer controlled duct rotator actuator **124** rotating the ducted fans **106** forward toward the position shown in FIGURE 4a to create forward movement until such speed is reached that sufficient airflow over the lifting surfaces creates lift, and the aircraft transitions from vertical to horizontal flight.

[0085] While in forward flight as shown in FIGURE 4a, the ducted fans **106** may remain in aerodynamic alignment with the fuselage **100** as with a conventional fixed wing aircraft. When transitioning from horizontal flight to vertical flight, the duct actuators **124** may be rotated upward to slow the forward motion as shown in FIGURE 4b. This decreases the air speed thus reducing the airflow over the lifting surfaces, and as the ducted fan **106** is rotated back to the upward position, it may increase the vertical thrust of the variable pitch blades. The actuators **124** may turn the ducted fans **106** past vertical as shown in FIGURE 4c to slow the aircraft to a complete stop of forward motion. The tilted duct rotator actuator **124** may also control forward and reverse motion in hover by moving the ducts **106** forward or backward, respectively.

DESCRIPTION OF ALTERNATIVE EMBODIMENT – UAV

[0086] In this embodiment, the aircraft may be adapted to perform as an unmanned aerial vehicle or UAV. This embodiment may include the sideways engine placement and in-line alignment and the fans encased in ducts as described for previous examples above. Most of the configuration of the aforementioned embodiment may remain intact, but some differences may be provided to help reduce the radar signature and to help provide for the carrying of weapons, large payloads, surveillance equipment, or the like. The aircraft and the engine may be scaled up or scaled down to accommodate different weight and/or mission objectives.

[0087] The UAV embodiment may include the same tail configuration of the previous examples, that is, the vertical stabilizers with the horizontal tail atop them, or as pictured in FIGURE 5, it may utilize a V-tail assembly **501** and may include horizontal stabilizers **502** attached to the sides of and/or to the rear of the ducts (not shown). This V-tail configuration is similar to that of the Raptor F-22.

[0088] Other differences may include a retractable landing gear instead of a fixed landing gear, foldable wings or changeable wings for high altitude and other applications, a large compartment in place of a passenger cabin, and a camera location in the nose cone for surveillance. The cabin canopy may be manufactured of an opaque material rather than a transparent material and may become more aerodynamically streamlined by incorporating a lower profile. Bomb bay doors which open at the bottom of the aircraft for deployment of weapons, emergency food supplies, or the like may improve stealth capabilities because those items may be hidden and encased in the fuselage rather than placed on the wings.

[0089] The UAV embodiment may be used for military and reconnaissance operations for close in support. The UAV embodiment may also be used as an emergency vehicle to pick up wounded or stranded people in a dangerous location. The bolt-on or

foldable wings may allow it to be trailered to a nearby or safe location before being sent on a mission. Thinner and longer wing extensions may accommodate higher altitudes and longer loitering. The ability of the aircraft to fly with one engine shut down and to take-off and land in close proximity to a target area may increase the distance the aircraft can fly on its designated fuel allowance. The engine may have the ability to alternate piston firings which also may increase fuel economy while keeping the aircraft aloft using very little horsepower.

[0090] Since the fan blades may be encased in ducts, and since ducted fans are quieter than propellers or jet engines, less radar signature may be produced. Also, since the engines may be mounted in the fuselage, less infrared signature may be produced. Stealth may therefore be much improved.

[0091] In some embodiments, most or all of the cabin area between the two engines may be used for storage of weapons, cargo and supplies, and/or surveillance equipment. VTOL capabilities may allow the aircraft to get closer to a target or to get into tight areas as for a rescue. The ability to take off and land in conventional mode may provide for more carrying capacity because the wings may be used for lift so the aircraft may carry more fuel and weight. Once the fuel has burned off on a long flight, a vertical landing is possible.

[0092] The V-tail configuration **501** could also be utilized on the passenger embodiments to improve the speed of the aircraft.

DESCRIPTION OF ALTERNATIVE EMBODIMENT - SPORT PLANE

[0093] FIGURE 6 shows an alternative embodiment of this invention as a VTOL sport plane. This embodiment may be comprised of an elongated aerodynamic fuselage with one double-ended driveshaft engine mounted sideways with respect to the fuselage and with a rotatable ducted fan **106** on each end of a main fixed wing **605** for a total of two ducted fans. The wing **605** may be level, dihedral, or anhedral. A passenger compartment/cabin **600** in the front portion of the fuselage may accommodate one or two people, and the engine may be

located in the fuselage just behind cabin **600** and in line with the wing **605**. An emergency parachute compartment may be located behind the passenger cabin **600** and just above the engine. The aircraft may have a fixed or retractable tricycle landing gear with one attached to the front **601** of the fuselage and two **602**—one left and one right—attached to the bottom of the fuselage behind and below the passenger compartment **600**.

[0094] In this embodiment, the engine, driveshaft, transfer case, duct rotator actuator, and ducted fans **106** may be provided for wing **605** in like manner as described above for canard wing **123** (see FIGS. 1, 2a, 2b). The double-ended driveshaft from each end of the engine may exit the fuselage through a transfer case, bearing, or other suitable support, run inside the main fixed wing **605**, continue through a duct rotator actuator, and continue through a side of the ducted fan **106** and into a mid portion of the ducted fan **106** where it connects to a differential. As the driveshaft exits the right end of the engine, it runs through the right side of the wing and enters the right ducted fan **106** through the left side; and as the driveshaft exits the left end of the engine, it runs through the left side of the wing and enters the left ducted fan **106** through the right side. Inside each ducted fan **106**, the differential may have two output shafts with each one turning one row of blades. Therefore, the two output shafts may respectively turn two rows of counter rotating blades in each ducted fan **106**.

[0095] Two air deflectors—one vertical **110** and one horizontal (not shown in FIGURE 6)—may be attached to the rear of each ducted fan **106**. These deflectors may employ a DSS (Duct Stabilization System) and may use splitting capabilities to control the output thrust for increased stability. The horizontal air deflector may move the aircraft forward and backward, and may provide counter rotation of the aircraft in hover. The vertical air deflector may move the aircraft sideways in hover. In conventional airplane mode, the horizontal air deflector may control the roll.

[0096] The rear fuselage of the aircraft may be long and streamlined with a cruciform shaped tail comprised of one left **604** and one right (not shown) horizontal surface and one top **603** and one bottom vertical surface (not shown) controlling pitch and yaw, respectively, while the aircraft is in conventional airplane mode.

DESCRIPTION OF FURTHER ALTERNATIVE EMBODIMENTS

Multiple engines placed end to end

[0097] In this embodiment, as shown in FIG. 2b, two or more engines may be provided fore, and two or more engines may be provided aft. Each set of engines may be placed end to end and sideways with respect to the fuselage. A common driveshaft or coupled driveshafts which act as one driveshaft **226** may run through the multiple engine blocks, with the shaft output on the outside ends of the outside engines running a pair of propellers or ducted fan blades. In this example, a transfer case may not be necessary for a backup for a dead engine, although a transfer case and supplemental drive shaft may be provided for further redundancy. The dead engine shaft may be driven by the running engine and/or engines with the dead engine freewheeling. The propellers or ducted fan blades may keep turning but at reduced power.

[0098] In some embodiments, freewheeling may be accomplished by coupling multiple engines (two or more) in-line with a continuous or coupled driveshaft and/or camshaft to effectively create a single power source and to provide for the freewheeling of one or more engines or for all of the engines, further described as follows. The freewheeling system may be formed by placing two or more engines (power sources) end to end and with each combined engine having a common driveshaft (which may be one integral, continuous shaft or multiple shafts coupled together) enabling the other engine or engines to freewheel. The sizes, horsepower, and types of power sources for such embodiments may be identical or varied. Output shafts for freewheeling can be utilized from each end, or from only one end,

or from the middle of the coupled or continuous shafts. Coupling of multiple power sources may provide for the capability of freewheeling of one or more power sources while one or more other power sources are providing power to the other end of the freewheeling engine(s). It may also provide for all of the power sources to run together or for all power sources to freewheel together. If one power source fails, the other power source(s) will continue to turn the driveshaft, thus providing redundancy and enhanced safety.

[0099] In some embodiments, each of the power sources may provide a different power level for the coupled unit; e.g., if three power sources are coupled, one power source could be at idle, one could be at medium power, and one could be at full power, or alternatively all the power sources could be working at full power. More generally, each power source may be utilized at any selected power level. Significant fuel savings may result from regulating the power to only what is necessary at a given flight condition. In addition, any combination of the power sources could be selected to power or freewheel, and the power sources may be alternately selected so that the hours on each of the power sources may be maintained at a similar level if needed.

[0100] In some embodiments, coupling of the power sources with the resultant freewheeling capability may eliminate the need between units for clutches, transmissions, torque converters and/or differentials. This may simplify manufacturing and operations, thereby reducing costs of operation and maintenance and increasing safety. Alternatively, various freewheeling devices may be interposed between a power source and the driveshaft if needed.

[0101] In some embodiments, coupling two or more different types of power sources—such as one heat source (e.g., internal combustion or jet engine) and one electrical source, for example—may provide for various capabilities. The heat source may be utilized to turn an electric source into a generator, thus letting the heat source charge batteries, for

example. The heat source may provide power while freewheeling the electric source. Alternatively, the electric source may provide power by freewheeling the heat source, or both the heat source and the electric source may be used together to provide hybrid power. As another alternative, both sources may be freewheeled and used in a regenerating mode to turn the electric source into a generator and provide braking and electrical current to charge batteries.

[0102] In some embodiments, the multi-source unit being used to power a generator(s) may continue to generate power—even with the loss of an engine—because the other engine(s) may accelerate to compensate for the dead engine, thus eliminating or minimizing loss of power.

[0103] In some embodiments, some of the power units for which this freewheeling concept may work best may be power sources which produce very little friction when the power source is freewheeling and the continuous or coupled driveshaft(s) are in-line, thus using internal driveshafts/crankshafts/cam shafts as the drive line. The internal mechanical parts of the engine may be used as the continuous drive line which turns the output shaft with power from the other power source(s).

[0104] In some conventional aircraft applications, coupling the engines for freewheeling may make it possible for one drive shaft from one end of the coupled power units to turn one propeller unit. This configuration may eliminate the need for other drive shafts when a back-up engine is needed, thereby reducing drag while still providing the “back-up” safety element of conventional twin engines or multi-engines.

[0105] In some embodiments, the freewheeling system may also work inside nacelles; e.g., by placing propellers on one end of multiple engines, between the engines, or at each end of the engines. This configuration may also be used to retrofit an existing aircraft by placing a propeller at one end of combined engines.

[0106] In some embodiments, this coupled and freewheeling power generating unit may provide both power and back-up power from each end or from one end of the coupled power unit and may be used in a VTOL aircraft to provide for powering the aircraft. It may also be used to improve the powering of existing VTOL aircraft currently in design, production, and/or use. Currently, many of these aircraft have propellers and blades at the end of the engines or in the ducts with their power units creating safety issues if one engine fails. In some embodiments, coupling engines together may allow the use of smaller engines thereby reducing the cost of manufacturing, especially for electric motors, since smaller engines generally cost less to manufacture.

[0107] Some examples of reduced friction power units that may be used for coupling may include engines such as the Perlex™, Axial Vector™, Sinusoidal Cam™, Dyna-Cam™, Radmax™, Rand-Cam™, Wankel™, and any cylindrical rotor, rotor, rotary, mill, vane, turbine, jet, electric and any other reduced friction power units capable of using its internal drive shafts in freewheeling applications as described herein. Alternatively, some conventional engines may be used if the amount of friction produced in them may be reduced.

[0108] In some embodiments, freewheeling may be provided in connection with actuators and servo motors. As shown in Figures 3A and 3B, a common shaft 307, 310 may be provided between the two actuators 107 and 210, which may be connected to allow redundancy for the control of the variable pitch blades 108 and 109 by allowing the freewheeling of a failed actuator. In some embodiments, common shaft 307, 310 may be hollow with a rod traversing through the middle, with the outer portion of the shaft serving to power blades 108, 109 and the inner rod serving to connect actuators 107, 210, such that if one of the actuators 107, 210 loses power the other of the actuators 107, 210 may continue to control the pitch of the first and second rows of blades 108, 109. This type of application

may also be applied to many different scenarios for backup systems. For example, actuators and servo motors may be stacked (i.e., operably engaged with a common driveshaft) like the multiple engines described above, or separated and equipped with separate power sources in the event one power source fails. Such actuators and servo motors may be connected by a common shaft thus allowing freewheeling of a dead actuator or servo motor.

[0109] Some embodiments may have two engines fore and two engines aft with each pair of engines comprising a first engine fore and a next engine aft. Each pair of engines may be placed end to end and in-line and sideways with respect to the fuselage. Each engine may be controlled separately with the driveshaft from the right engine turning the propellers or ducted fan blades on the right side of the aircraft and with the driveshaft from the left engine turning the propellers or ducted fan blades on the left side of the aircraft. Transfer cases may be used in this example to pick up the power from the other engines.

Emergency Rescue Vehicle

[0110] This embodiment may use modifications to provide for an emergency rescue vehicle. The changes comprise shortened wings, a stubby nose, a front canopy that would fold or retract backwards, and a platform addition which would facilitate emergency escapes. The emergency vehicle could nose in to a building, cliff, or the like to provide an escape route for people trapped in, for example, a burning building. Ducted fans—as opposed to propellers—may permit the aircraft to get next to structures or into tight areas. The stubby nose and retractable canopy may allow access to the aircraft. An extendible/retractable ramp in the nose section may provide a stable emergency escape route.

[0111] Various embodiments of the aircraft described herein may utilize one or more of various types of engines, including Axial Vector, Dyna-Cam type engines, internal combustion, radial, piston, reciprocating, rotary, rotor, StarRotor, vane, mill, electric, hybrid, diesel, or similar type engines, alone or in combination, mounted in-line and sideways with

respect to the fuselage. Hybrid engines may include one or more of each of a plurality of engine types. For example, a hybrid engine may include a diesel portion and an electric portion.

[0112] In some embodiments, an electric engine may have a first mode in which the electric engine drives the driveshaft and a second mode in which the electric engine serves as a generator driven by the driveshaft and charges a battery electrically connected to the electric engine. For example, the electric engine may operate in the first mode during take-off, and the electric engine may operate in the second mode after take-off.

[0113] In some embodiments, the front ducted fans may be mounted at the end of the canard wing, and the rear ducted fans may be mounted on each side of the fuselage just behind the passenger canopy. However, in other embodiments, the ducted fans may be mounted on each side of the front part of the fuselage, on each end of the main wing, and/or on the tail, depending upon the configuration of the aircraft.

[0114] In some embodiments, propellers may be utilized to handle larger loads with less horsepower, and the engines may be mounted in a higher position on the fuselage to provide clearance for the propellers. This configuration may accommodate from six to ten passengers or a large payload, for example.

[0115] Any or all of the embodiments may utilize an emergency parachute system. The aircraft may be equipped with a parafoil type parachute and one or more deployment rockets for emergencies. The deployment rockets may be solid fuel, liquid fuel, gaseous fuel, or a combination thereof. The parachute may primarily be used while in hover mode or at slow speeds, but may be used in other flight conditions if necessary or desired. The parachute and rockets may be mounted in the top of the rear portion of the fuselage behind the rear cabin, with one rocket on each side, for example. A cable system may be imbedded in the fuselage with a breakaway covering as described above. The supporting cables may be

attached to the airframe at four attachment points as described above—two in the front fuselage near the outside end of the front engine and two in the rear fuselage near the outside end of the rear engine. The risers from the parachute may be attached to the supporting cables.

[0116] The emergency parachute may be deployed by the pilot via an emergency hand lever if the aircraft is in forward flight, or it may be automatically deployed by a computer if an engine loses power or the aircraft becomes unstable in hover or other flight condition. The parachute system may deploy the rockets, shooting them out at an angle and pulling the ends of the parafoil parachute in opposite directions, thereby moving the parachute away from the aircraft appendages and stretching the canopy to the full length of the parachute.

[0117] Airbag technology with small elongated tubes embedded in the parachute canopy cords and the outer edges of the parachute system may be utilized to immediately expand the parachute into the ultimate shape of a fully deployed parachute. The canopy may then be ready to receive the air, and this may result in the aircraft suffering a very slight loss of altitude from the time the parachute deploys until it is filled with air.

[0118] If the aircraft is moving in forward flight, computer controlled air sensors may determine if a need exists to apply or delay deployment of the airbag expander of the air canopy. This may minimize the shock from the forward air speed. When the parachute is opened, it may be steered via controls inside the aircraft. The parafoil parachute may give the aircraft a forward motion to help steer the aircraft to a safe area for a landing while descending under the parachute. If one engine is still operating, the parachute may act as a parasail to help keep the aircraft aloft while the pilot leaves a dangerous area and searches for a safe landing site.

[0119] Since the emergency parachute may be computer controlled in hover or other flight condition, it is possible the emergency backup transfer case and supplemental driveshafts may be bypassed or eliminated from certain embodiments thereby streamlining and simplifying the design of the output shafts from the engine to each differential. This may significantly reduce the weight of the aircraft.

[0120] The embodiments described above are some examples of the current invention. Various modifications, applications, substitutions, and changes of the current invention will be apparent to those skilled in the art. Further, it is contemplated that features disclosed in connection with any one embodiment, system, or method may be used in connection with any other embodiment, system, or method. The scope of the invention is defined by the claims, and considering the doctrine of equivalents, and is not limited to the specific examples described herein.

CLAIMS

WHAT IS CLAIMED IS:

1. An aircraft comprising:
 - a fuselage having a longitudinal axis;
 - a left wing extending from said fuselage;
 - a right wing extending from said fuselage;
 - a tail section extending from a rear portion of said fuselage;
 - a first engine disposed in said fuselage;
 - a second engine disposed in said fuselage;
 - said first and second engines being operably connected to a first common driveshaft having an axis of rotation oriented transverse to said longitudinal axis of said fuselage;
 - a first propeller rotatably mounted to said left wing and operably connected to said first common driveshaft; and
 - a second propeller rotatably mounted to said right wing and operably connected to said first common driveshaft;
 - wherein said first and second engines are configured for freewheeling such that if one of said first and second engines loses power the other of said first and second engines continues to power said first and second propellers.
2. The aircraft of claim 1 wherein each of said first and second propellers comprises a ducted fan.
3. The aircraft of claim 1 wherein said first and second engines are of the same type.
4. The aircraft of claim 1 wherein said first and second engines are of different types.
5. The aircraft of claim 4 wherein one of said engines comprises a heat source and the other of said engines comprises an electric engine.

6. The aircraft of claim 5 further comprising a generator mode wherein said electric engine is configured to serve as a generator powered by said heat source.

7. The aircraft of claim 1 wherein said left and right wings comprise canard wings, said aircraft further comprising:

a main wing extending from a middle portion of said fuselage;

a third engine disposed in said fuselage;

a fourth engine disposed in said fuselage;

said third and fourth engines being operably connected to a second common driveshaft having an axis of rotation oriented transverse to said longitudinal axis of said fuselage;

a third propeller rotatably mounted to a left rear portion of said fuselage and operably connected to said second common driveshaft; and

a fourth propeller rotatably mounted to a right rear portion of said fuselage and operably connected to said second common driveshaft;

wherein said third and fourth engines are configured for freewheeling such that if one of said third and fourth engines loses power the other of said third and fourth engines continues to power said third and fourth propellers.

8. The aircraft of claim 7 further comprising:

a forward transfer case operably connected to said first common driveshaft;

a rear transfer case operably connected to said second common driveshaft; and

a supplemental driveshaft operably connected to said forward transfer case and said rear transfer case.

9. An aircraft comprising:

a fuselage;

a left wing extending from said fuselage;

a right wing extending from said fuselage;
a tail section extending from a rear portion of said fuselage;
a first engine disposed in said fuselage;
a second engine disposed in said fuselage;
said first and second engines being operably connected to a common driveshaft; and
a propeller operably connected to said common driveshaft;

wherein said first and second engines are configured for freewheeling such that if one of said first and second engines loses power the other of said first and second engines continues to power said propeller.

10. The aircraft of claim 9 wherein said driveshaft comprises an axis of rotation transverse to a longitudinal axis of said fuselage.

11. The aircraft of claim 9 wherein power produced by each of said engines is selectable.

12. The aircraft of claim 9 wherein one of said engines comprises an internal combustion engine and the other of said engines comprises an electric motor.

13. The aircraft of claim 9 wherein said propeller comprises a ducted fan.

14. An aircraft comprising:

a fuselage;

a left wing extending from said fuselage;

a right wing extending from said fuselage;

a tail section extending from a rear portion of said fuselage;

a first engine disposed in said fuselage;

a second engine disposed in said fuselage;

said first and second engines being operably connected to a first common driveshaft;

a first ducted fan rotatably mounted to said left wing and operably connected to said first common driveshaft;

a second ducted fan rotatably mounted to said right wing and operably connected to said first common driveshaft;

wherein said first and second engines are configured for freewheeling such that if one of said first and second engines loses power the other of said first and second engines continues to power said first and second ducted fans; and

wherein each of said ducted fans comprises a first actuator operably connected to a first row of blades and a second actuator operably connected to a second row of blades, wherein said first and second actuators are operably connected by a second common driveshaft, and wherein said actuators are configured for freewheeling such that if one of said first and second actuators loses power the other of said first and second actuators continues to control pitch of said first and second rows of blades.

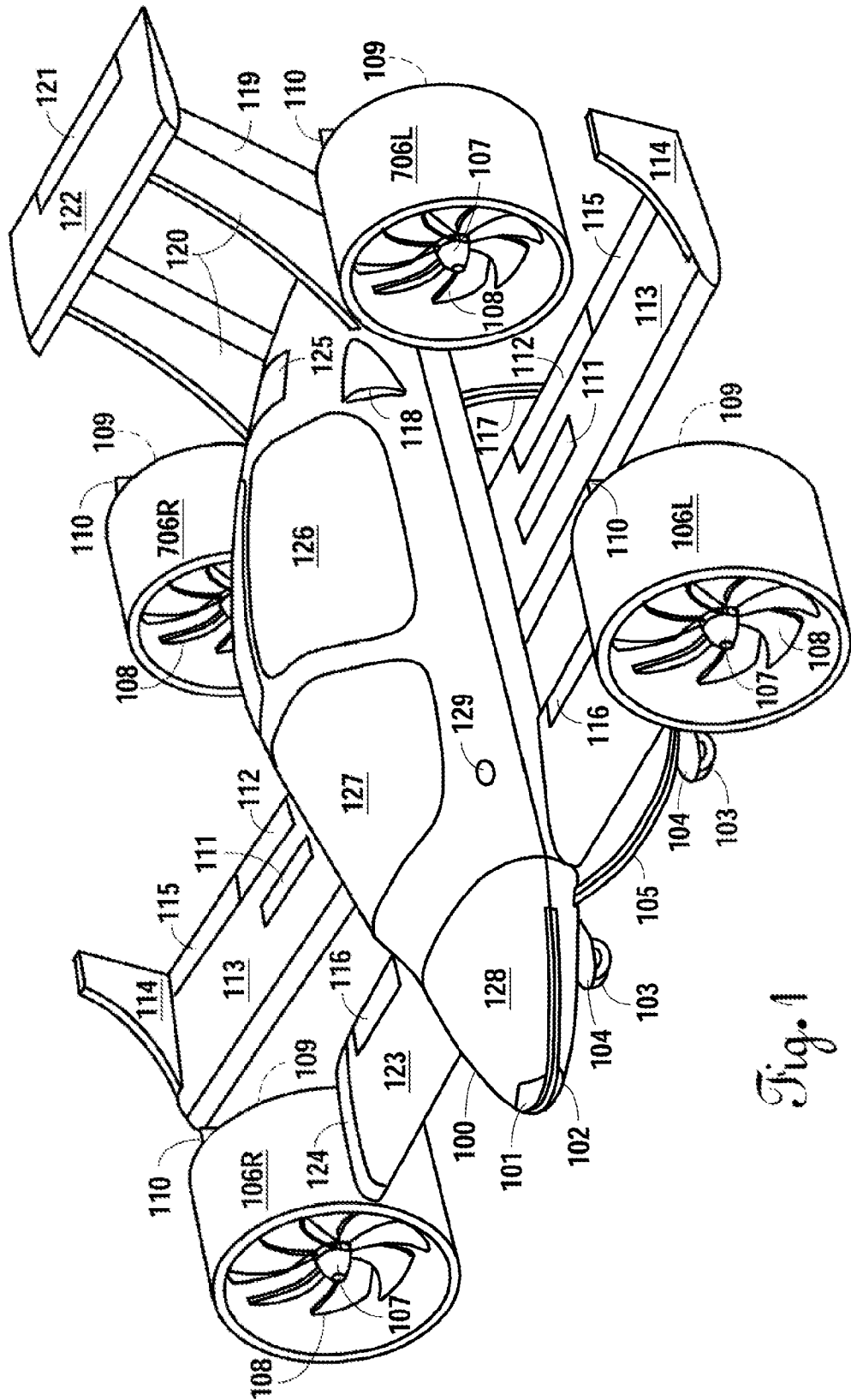

Fig. 1

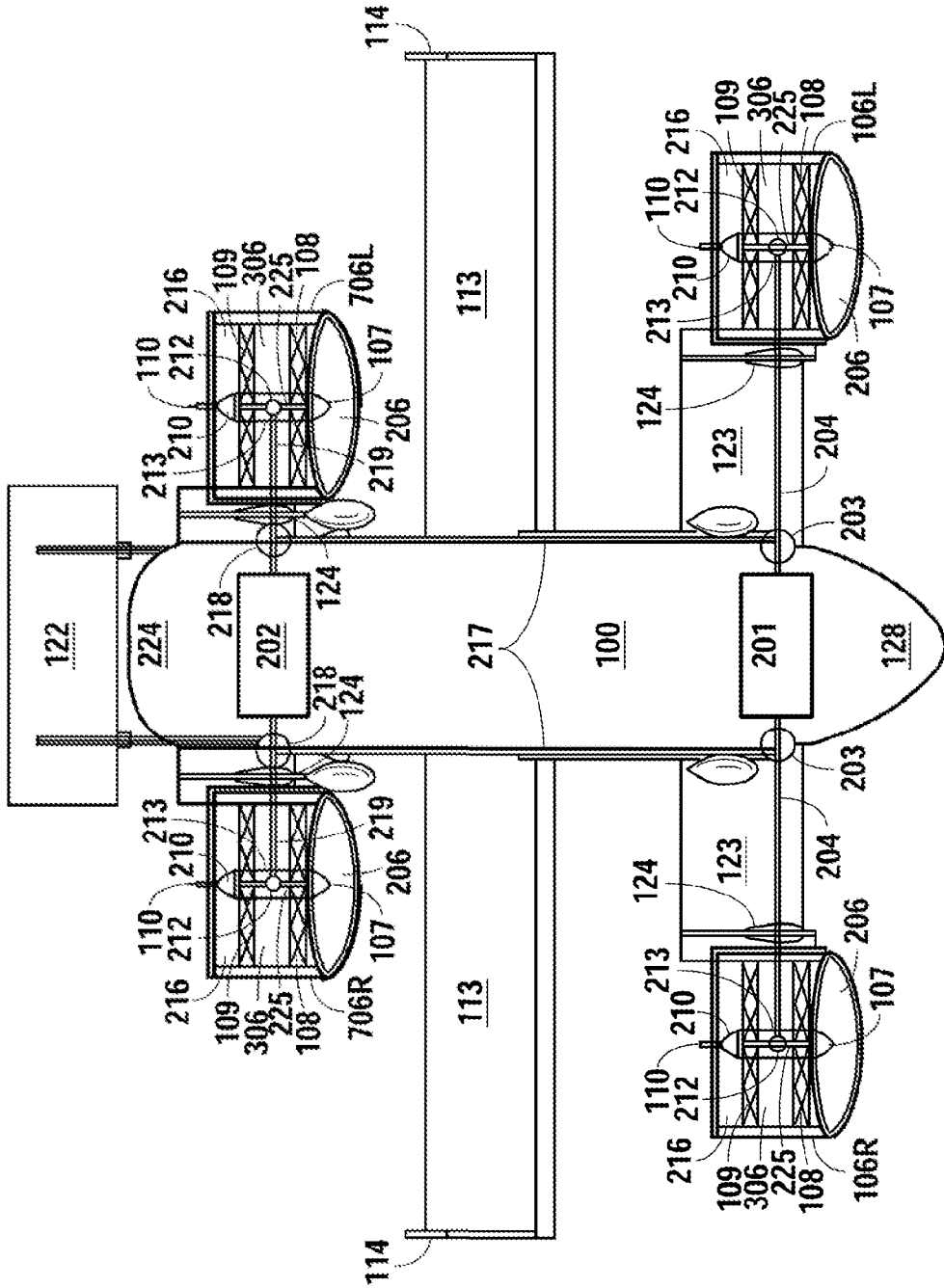

Fig. 2a

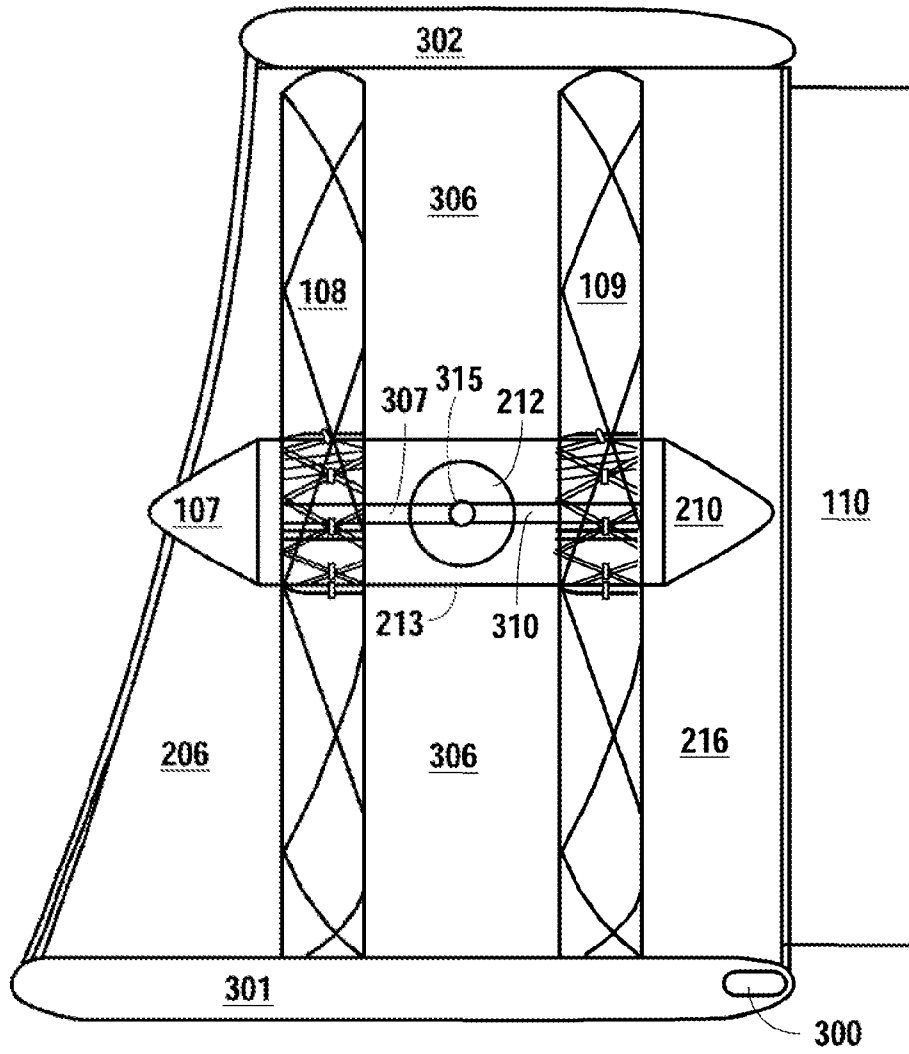

Fig. 3a

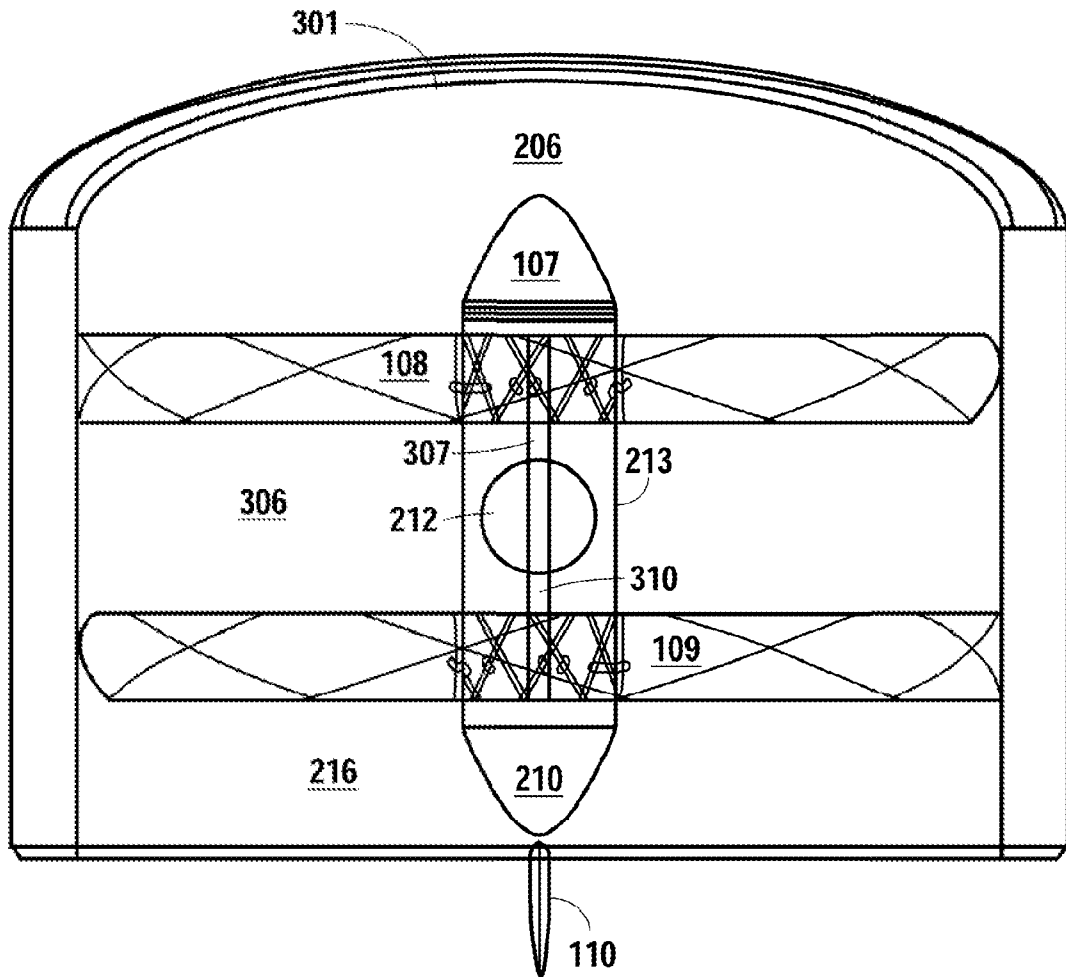

Fig. 3b

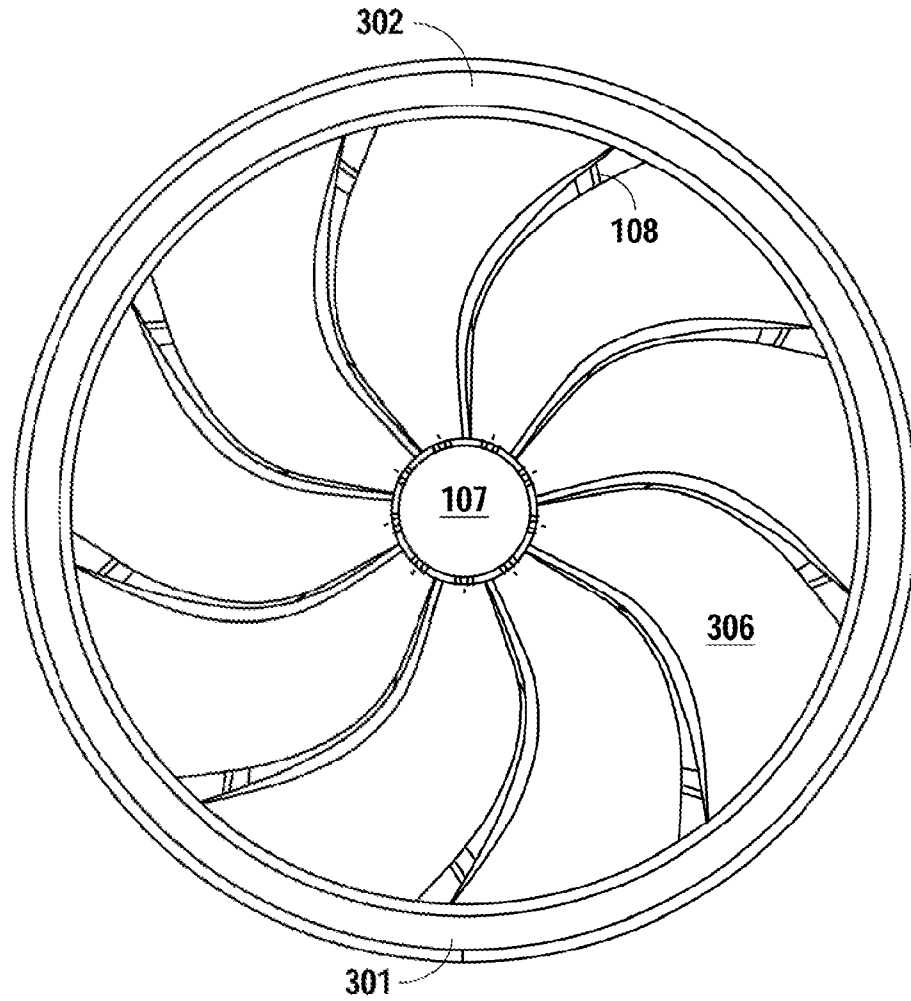
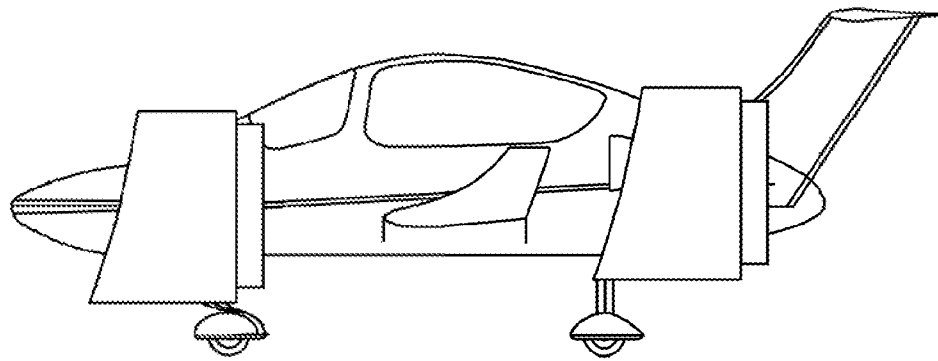
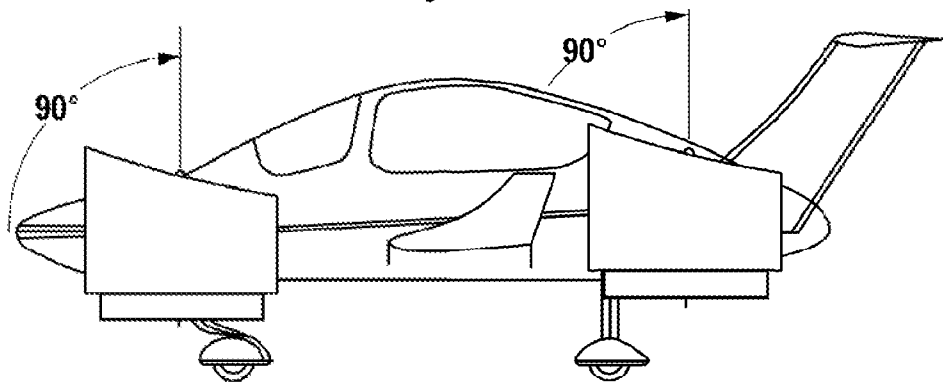

Fig. 3c



**DUCT POSITION-FORWARD FLIGHT
WITH FORWARD THRUST**

Fig. 4a



**DUCT POSITION-VERTICAL LIFT
AND HOVER**

Fig. 4b

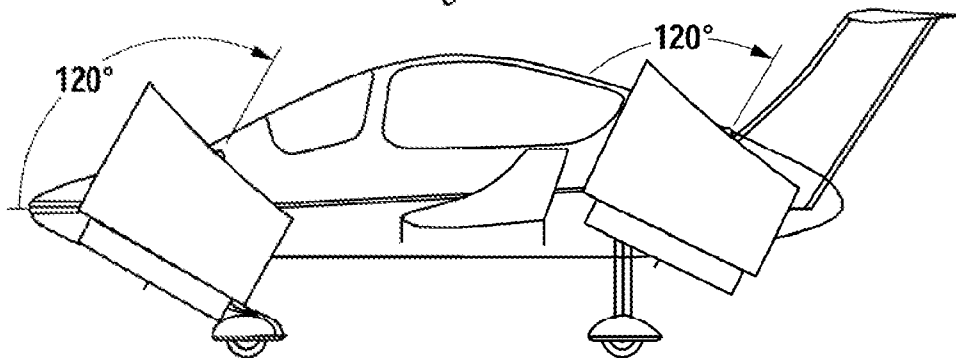

**DUCT POSITION-BRAKING POSITION
WITH REVERSE THRUST**

Fig. 4c

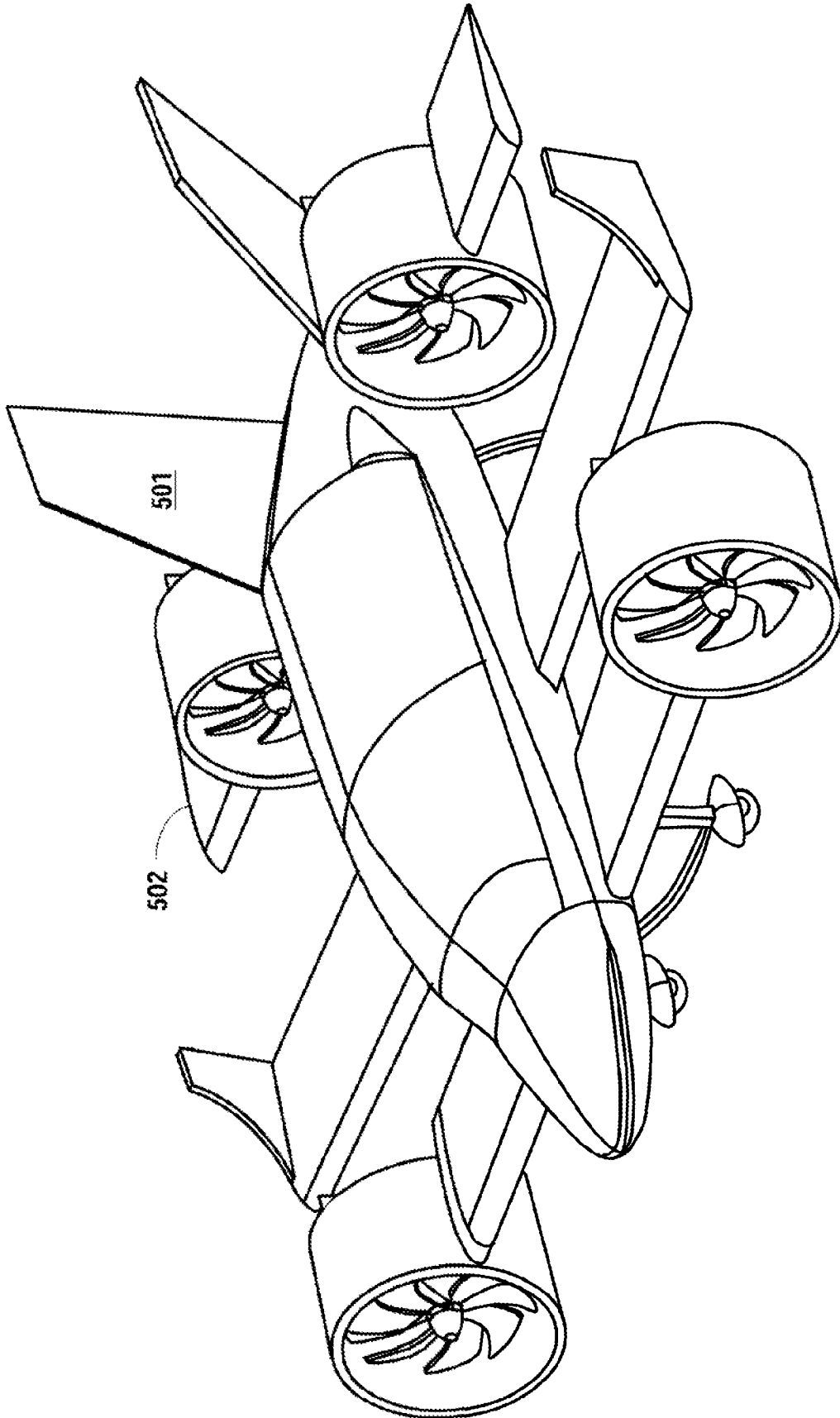

Fig. 5

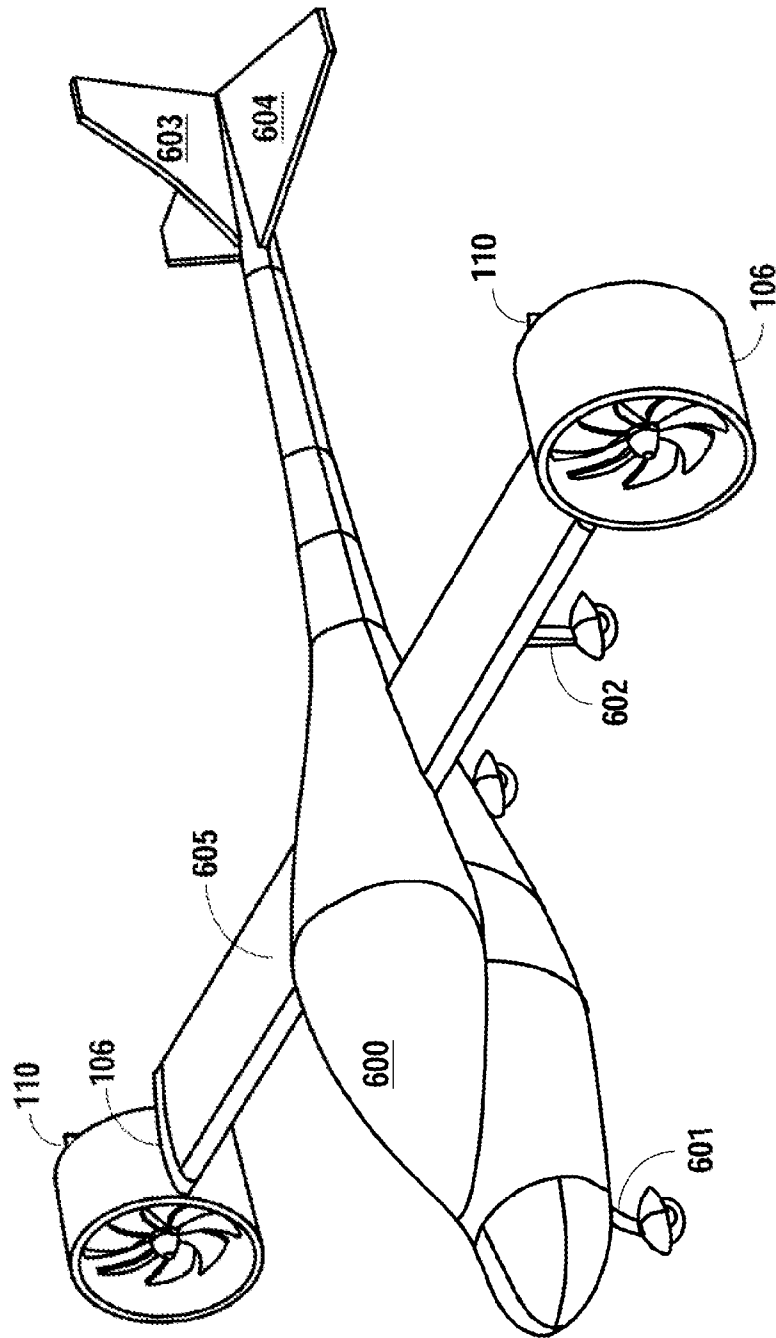

Fig. 6

INTERNATIONAL SEARCH REPORT		International application No. PCT/US13/33985
A. CLASSIFICATION OF SUBJECT MATTER IPC: B64C 15/00(2006.01),29/00(2006.01),27/08(2006.01),27/52(2006.01);B63H 5/10(2006.01) USPC: 244/12.1-12.5,23R-23D,17.23,17.25,60,6-7C;416/124,125,127 According to International Patent Classification (IPC) or to both national classification and IPC		
B. FIELDS SEARCHED		
Minimum documentation searched (classification system followed by classification symbols) U.S. : 244/12.1-12.5, 23R-23D, 17.23, 17.25, 60, 6-7C; 416/124, 125, 127		
Documentation searched other than minimum documentation to the extent that such documents are included in the fields searched		
Electronic data base consulted during the international search (name of data base and, where practicable, search terms used) Please See Continuation Sheet		
C. DOCUMENTS CONSIDERED TO BE RELEVANT		
Category *	Citation of document, with indication, where appropriate, of the relevant passages	Relevant to claim No.
X --- Y	US 2,929,580 A (CIOLKOSZ) 22 March 1960 (22.03.1960), see entire document.	1-3, 9-11, 13 ----- 4-7, 12, 14
Y	US 6,295,487 B1 (ONO et al.) 25 September 2001 (25.09.2001), see entire document.	4-6, 12
Y	US 6,691,949 B2 (PLUMP et al.) 17 February 2004 (17.04.2004), see entire document.	14
Y	US 3,298,633 (DASTOLI et al.) 17 January 1967 (17.01.1967), see entire document.	1-3, 7, 9-11, 13
Y	US 1,547,434 A (MICHAUD) 28 July 1925 (28.07.1925), see entire document.	8
A	US 1,322,976 A (TWOMBLY) 25 November 1919 (25.11.1919), see entire document.	1-14
<input type="checkbox"/> Further documents are listed in the continuation of Box C.		<input type="checkbox"/> See patent family annex.
* Special categories of cited documents: "A" document defining the general state of the art which is not considered to be of particular relevance "E" earlier application or patent published on or after the international filing date "L" document which may throw doubts on priority claim(s) or which is cited to establish the publication date of another citation or other special reason (as specified) "O" document referring to an oral disclosure, use, exhibition or other means "P" document published prior to the international filing date but later than the priority date claimed		"T" later document published after the international filing date or priority date and not in conflict with the application but cited to understand the principle or theory underlying the invention "X" document of particular relevance; the claimed invention cannot be considered novel or cannot be considered to involve an inventive step when the document is taken alone "Y" document of particular relevance; the claimed invention cannot be considered to involve an inventive step when the document is combined with one or more other such documents, such combination being obvious to a person skilled in the art "&" document member of the same patent family
Date of the actual completion of the international search 18 November 2013 (18.11.2013)		Date of mailing of the international search report 22 NOV 2013
Name and mailing address of the ISA/US Mail Stop PCT, Attn: ISA/US Commissioner for Patents P.O. Box 1450 Alexandria, Virginia 22313-1450 Facsimile No. (571) 273-3201		Authorized officer William Krynski Telephone No. 571-272-1700

INTERNATIONAL SEARCH REPORT

International application No.
PCT/US13/33985

Continuation of B. FIELDS SEARCHED Item 3:

USPAT; US-PGPUB; USOCR; FPRS; EPO; JPO; DERWENT; IBM_TDB: engine, heat, combustion, piston, reciprocating, turbine, rotary, electric, electro, electromechanical, motor, generator, generation, charge, charging, recharge, recharge, propeller, rotor, fan, ductfan, tilt, tilting, tilted, rotatably, rotatable, swivel, swiveled, swiveling, pivot, pivoted, pivoting, aircraft, airplane, airliner, aeroplane, aerodyne, air, airborne, flying, flight, vehicle, platform, object, quadrotor, driveshaft