

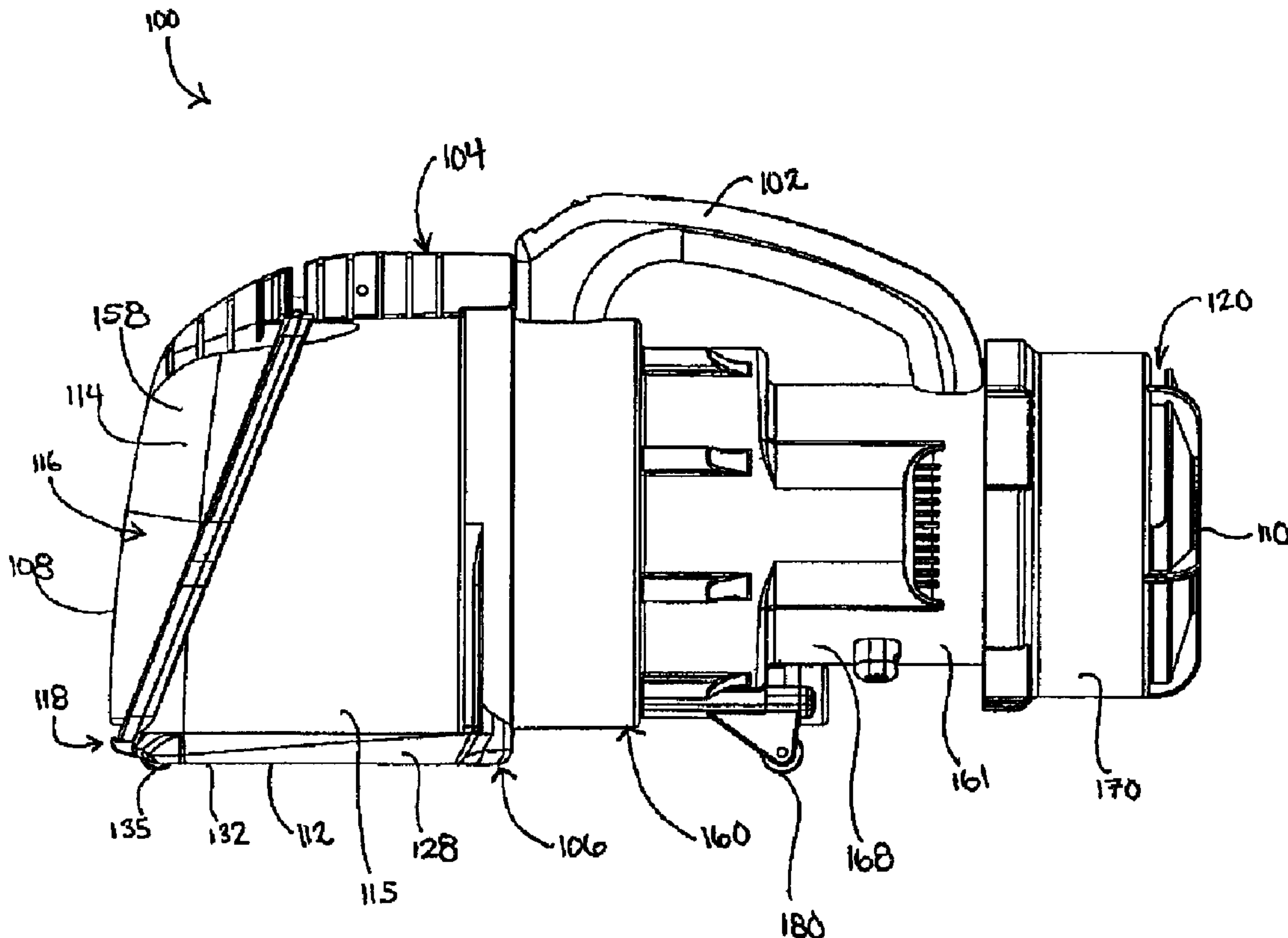

(22) Date de dépôt/Filing Date: 2009/03/13
(41) Mise à la disp. pub./Open to Public Insp.: 2010/09/13

(51) Cl.Int./Int.Cl. *A47L 9/16* (2006.01),
A47L 5/24 (2006.01)
(71) Demandeur/Applicant:
G.B.D. CORP., BS
(72) Inventeur/Inventor:
CONRAD, WAYNE ERNEST, CA
(74) Agent: BERESKIN & PARR LLP/S.E.N.C.R.L.,S.R.L.

(54) Titre : APPAREIL DE NETTOYAGE DE SURFACES
(54) Title: SURFACE CLEANING APPARATUS



(57) Abrégé/Abstract:

A surface cleaning apparatus comprises a cyclone having an open end dirt outlet and a plate facing the open end, the height of a gap between the plate the open end is not constant.



ABSTRACT

A surface cleaning apparatus comprises a cyclone having an open end dirt outlet and a plate facing the open end, the height of a gap between the plate the open end is not constant.

5

TITLE: SURFACE CLEANING APPARATUS

FIELD

[0001] The specification relates to surface cleaning apparatuses. More specifically, the specification relates to cyclonic surface cleaning apparatuses.

5 INTRODUCTION

[0002] The following is not an admission that anything discussed below is prior art or part of the common general knowledge of persons skilled in the art.

[0003] Cyclonic vacuum cleaners utilize one or more cyclones that have an associated dirt collection chamber. The dirt collection chamber may be formed
10 in the bottom of a cyclone chamber. A disc or divider may be positioned in the cyclone casing to divide the cyclone casing into an upper cyclone chamber and a lower dirt collection chamber. It is also known to position a dirt collection chamber exterior to a cyclone casing, such as surrounding the cyclone chamber.

SUMMARY

15 [0004] The following introduction is provided to introduce the reader to the more detailed discussion to follow. The introduction is not intended to limit or define the claims.

[0005] According to one broad aspect, a surface cleaning apparatus is provided that utilizes a cyclone having an open end, wherein the open end
20 comprises the dirt outlet of the cyclone. A plate, that preferably has a planar surface facing the open end, is positioned facing the open end. For example, the plate may line in a plane that is perpendicular to the longitudinal axis extending through a cyclone chamber and may be spaced from the open end. Accordingly, a gap is provided between the plate and the open end and defines a dirt outlet of the
25 cyclone. In accordance with this aspect, the gap has a non uniform length.

[0006] For example, the cyclone casing may have a variable length. The portion that have a shorter length define a gap having a increased height.

Alternately, or in addition, the plate may be provided with a sidewall on the side of the plate facing the open end of the cyclone. The sidewall may extend part way around the plate. The height of the wall maybe constant or may be variable.

[0007] The sidewall is preferably provided on the periphery of the plate.

5 The diameter of the plate is preferably about the same as the diameter of the open end of the cyclone.

[0008] In some embodiments, the sidewall of the plate has a constant length. In other embodiments, the sidewall of the plate has a variable length.

[0009] In some embodiments, the sidewall of the cyclone has a first end at
10 the open end, the first end has a perimeter, and the gap has a first portion having a first length and a second portion having a second length greater than the first length. The first length and the second length may be constant. Alternately, the first length and the second length may be variable.

[0010] In some embodiments, one of the portions extends up to 210° of
15 the perimeter. For example, the second portion may extend up to 210° of the perimeter. In other embodiments, the second portion extends up to 240° of the perimeter.

[0011] According to another broad aspect, a surface cleaning apparatus is
20 provided. The surface cleaning apparatus comprises an air flow passage extending from a dirty air inlet to a clean air outlet. A suction motor is positioned in the air flow passage. A cyclone is positioned in the air flow passage. The cyclone comprises an air inlet, an air outlet, an open end, a longitudinal axis and a longitudinally extending sidewall. The side wall has a variable length. A dirt collection chamber is in flow communication with the open end.

25 [0012] In some embodiments, a first portion of the sidewall is longer than a second portion of the sidewall.

[0013] In some embodiments, the sidewall has a first end at the open end, the first end has a perimeter, and the first portion comprises up to 240° of the perimeter and the second portion comprises from up to 120° of the perimeter.

[0014] In some embodiments, the surface cleaning apparatus further
5 comprises a plate facing the open end. The plate may be spaced from a front end wall of the surface cleaning apparatus. A first portion of the dirt collection chamber may be provided between the plate and the front end wall. Preferably, a second portion of the dirt collection chamber surrounds at least a portion of the cyclone.

10 [0015] According to another broad aspect, another surface cleaning apparatus is provided. The surface cleaning apparatus comprises an air flow passage extending from a dirty air inlet to a clean air outlet. A suction motor is positioned in the air flow passage. A cyclone is positioned in the air flow passage. The cyclone comprises an air inlet, an air outlet, an open end, a
15 longitudinal axis and a longitudinally extending sidewall. A plate is provided having a cyclone side facing the open end. The plate is positioned to define a gap between the plate and the open end of the cyclone. The plate has a plate sidewall extending towards the open end. A dirt collection chamber is in flow communication with the open end.

20 [0016] In some embodiments, the plate sidewall extends part way around the plate. In some embodiments, the sidewall of the plate has a constant length. In other embodiments, the sidewall of the plate has a variable height.

[0017] Any of the surface cleaning apparatuses described herein may comprise a portable vacuum cleaner, and preferably, a hand vacuum cleaner.
25 The portable vacuum cleaner may be removably mountable to an upright vacuum cleaner.

[0018] It will be appreciated that an embodiment may contain one or more of features set out in the examples.

DRAWINGS

[0019] In the detailed description, reference will be made to the following drawings, in which:

5 [0020] Figure 1 is a side plan view of an example of a hand vacuum cleaner;

[0021] Figure 2 is a top plan view of the hand vacuum cleaner of Figure 1;

[0022] Figure 3 is a front plan view of the hand vacuum cleaner of Figure 1;

10 [0023] Figure 4 is a partially exploded rear perspective view of the hand vacuum cleaner of Figure 1;

[0024] Figure 5 is a partially exploded front perspective view of the hand vacuum cleaner of Figure 1;

[0025] Figure 6 is a cross section taken along line 6-6 in Figure 2;

15 [0026] Figure 7 is a bottom perspective view of the hand vacuum cleaner of Figure 1;

[0027] Figure 8 is a perspective illustration of the surface cleaning apparatus of Figure 1 mounted to an upright vacuum cleaner;

[0028] Figure 9 is a partially exploded front perspective view of an alternate embodiment of a hand vacuum cleaner; and,

20 [0029] Figure 10 is a cross section taken along line 10-10 in Figure 9.

DESCRIPTION OF VARIOUS EXAMPLES

[0030] Various apparatuses or methods will be described below to provide an example of each claimed invention. No example described below limits any claimed invention and any claimed invention may cover processes or apparatuses that are not described below. The claimed inventions are not limited to apparatuses or processes having all of the features of any one apparatus or

25

process described below or to features common to multiple or all of the apparatuses described below. It is possible that an apparatus or process described below is not an embodiment of any claimed invention.

[0031] Referring to Figures 1 to 7, a first example of a surface cleaning apparatus 100 is shown. Preferably, the surface cleaning apparatus 100 (also referred to herein as cleaner 100 or vacuum cleaner 100) is a portable vacuum cleaner 100, such as a hand vacuum cleaner 100 as shown. The hand vacuum cleaner 100 is movable along a surface to be cleaned by gripping and maneuvering handle 102. In alternate embodiments, the surface cleaning apparatus 100 may be another type of surface cleaning apparatus, such as a stick-vac, an upright vacuum cleaner, or a canister vacuum cleaner.

[0032] The exemplified embodiments are hand vacuum cleaners. The design for a cyclone and facing plate having a gap therebetween of non-uniform height may be used in any cyclonic cleaning apparatus. If the feature is used with a portable surface cleaning apparatus such as a hand vacuum cleaner, then the portable surface cleaning apparatus may be of any design. For example, as exemplified, the vacuum cleaner includes an upper portion 104, a lower portion 106, a front 108, and a rear 110. In the example shown, handle 102 is provided at the upper portion 104. In alternate examples, handle 102 may be provided elsewhere on the vacuum cleaner 100, for example at the rear 110 and may be of any design. The vacuum cleaner 100 may be of various configurations (e.g., different positioning and orientation of the cyclone unit and the suction motor and differing cyclone units that may comprise one or more cyclones and one or more filters) and may use any type of nozzle or position of the nozzle.

[0033] In the example shown, the vacuum cleaner 100 comprises a nozzle 112, which may be of any design, and a cyclone unit 114, which together form a surface cleaning head 116 of the vacuum cleaner 100. As exemplified, the surface cleaning head 116 is preferably provided at the front 108 of the vacuum cleaner 100.

[0034] Nozzle 112 engages a surface to be cleaned, and comprises a dirty air inlet 118, through which dirty air is drawn into the vacuum cleaner 100. An airflow passage extends from the dirty air inlet 118 to a clean air outlet 120 of the cleaner 100. In the example shown, clean air outlet 120 is at the rear 110 of the
5 cleaner 100.

[0035] Cyclone unit 114 is provided in the airflow passage, downstream of the dirty air inlet 118. In the example shown, the cyclone unit 114 comprises one cyclone 122 positioned in the airflow passage, and one dirt chamber 124. In alternate examples, the cyclone unit 110 may include more than one cyclonic
10 stage, wherein each cyclonic stage comprising one or more cyclones and one or more dirt chambers. Accordingly, the cyclones may be arranged in parallel and/or in sequence.

[0036] In the example shown, the nozzle 112 is positioned at the lower portion 106 of the vacuum cleaner 100. Preferably, as exemplified, nozzle 112 is
15 positioned at the bottom of the vacuum cleaner 100, and, preferably, beneath the cyclone unit 114. Accordingly, as exemplified, nozzle 112 may be on lower surface 117 of cyclone unit 114. In a particularly preferred design, the upper wall of the nozzle may be a lower wall of the cyclone unit 114. As shown in figure 6, dirt chamber 124 surrounds the lower portion of cyclone 122. Accordingly, the
20 upper wall of nozzle 112 may be part of the lower wall of the dirt chamber. It will be appreciated that if dirt chamber 124 does not extend around the lower portion of cyclone 122, then the upper wall of nozzle 112 may be part of a lower wall of cyclone 122.

[0037] Preferably, in the example shown, the nozzle 112 is fixedly
25 positioned at the lower portion 106 of the vacuum cleaner 100. That is, the nozzle 112 is not movable (e.g., rotatable) with respect to the remainder of the vacuum cleaner 100, and is fixed at the lower portion 106 of the vacuum cleaner 100.

[0038] As shown in Figures 3 and 5, nozzle 112 has a width W_N , and cyclone unit 114 has a width W_C . In the example shown, W_N and W_C are about the same. An advantage of this design is that the nozzle may have a cleaning path that is essentially as wide as the hand vacuum itself.

5 [0039] Preferably, nozzle 112 comprises an airflow chamber wherein at least a portion, and preferably a majority, of the lower surface of the chamber is open. In an alternate design, the nozzle may comprise a lower wall, which closes the lower end. Accordingly, nozzle 112 may be of various design and may be an open sided passage or a closed passage.

10 [0040] Nozzle 112 may also share a common wall with another component of cyclone unit 114. As exemplified in Figure 7, nozzle 112 comprises an upper nozzle wall 126, which defines a closed upper end of the airflow chamber 136. In the example shown, the upper nozzle wall 126 comprises a lower portion 119 of a wall 115 of the cyclone unit.

15 [0041] Preferably, one or more depending walls 128 extend downwardly from the upper nozzle wall 126. The depending wall is preferably generally U-shaped. In one embodiment, depending wall is provided rearward of opening 138. In other embodiments, depending walls may alternately or in addition be provided on the lateral sides of opening 138. It is preferred that depending walls
20 are provided on each lateral side of opening 138 and rearward thereof. Further, depending walls 128 may extend a substantial distance to the front end 108 and, preferably, essentially all the way to front end 108. The depending walls may be continuous to define a single wall as shown, or may be discontinuous. The depending walls are preferably rigid (e.g., integrally molded with cyclone unit
25 114). However, they may be flexible (e.g., bristles or rubber) or moveably mounted to cyclone unit 114 (e.g., hingedly mounted).

[0042] Preferably, the lower end 132 of depending wall 128 is spaced above the surface being cleaned when the hand vacuum cleaner is placed on a

surface to be cleaned. As exemplified in Figure 6, when vacuum cleaner 100 is placed on floor F, lower end 132 of depending wall 128 is spaced a distance H above the floor. Preferably distance H is from 0.01 to 0.175 inches, more preferably from 0.04 to 0.08 inches.

5 [0043] The height of the depending wall (between upper nozzle wall 126 and lower end 132) may vary. In some examples, the depending wall may have a height of between about 0.05 and about 0.875 inches, preferably between about 0.125 and about 0.6 inches and more preferably between about 0.2 and about 0.4 inches. The height of depending wall may vary but is preferably
10 constant.

[0044] As exemplified, the open end of the U-shape defines an open side 130 of the nozzle 112, and forms the dirty air inlet 118 of the cleaner 100. In the example shown, the open side 130 is provided at the front of the nozzle 112. In use, when optional wheels 135 are in contact with a surface, the open side 130
15 sits above and is adjacent a surface to be cleaned (e.g. floor F). Preferably, lower end 132 of depending walls 128 is spaced above floor F. Accordingly, some air may enter nozzle 112 by passing underneath depending wall 132. In such a case, the primary air entry to nozzle 112 is via open side 130 so that dirty air inlet 118 is the primary air inlet, with a secondary air inlet being under depending wall
20 128. In the example shown, the lower end 132 of the depending wall 128 defines an open lower end 134 of the nozzle 112. The open lower end 134 preferably extends to the front 108 of the cleaner 108, and merges with the open side 130.

[0045] In use, the exemplified nozzle has an open lower end 134 that faces a surface to be cleaned. In the example shown, a plurality of wheels 135
25 are mounted to the depending wall 128, and extend lower than the lower end 132 of the depending wall 128. Accordingly, in use, when wheels 135 are in contact with a surface, the lower end 132 of the depending wall 128 is spaced from a surface to be cleaned, and the space between the lower end of the depending wall 128 and the surface to be cleaned form a secondary dirty air inlet to the

vacuum cleaner 100. It will be appreciated that wheels 135 are optional. Preferably, wheels 135 are positioned exterior to the airflow path through nozzle 112, e.g., laterally outwardly from depending wall 128. Preferably a pair of front wheels 135 is provided. Preferably, the wheels are located adjacent front 108.

5 Optionally, one or more rear wheels 108 may be provided. In an alternate embodiment, no wheels may be provided.

[0046] The upper nozzle wall 126, depending wall 128, and open lower end 134 of the nozzle 112 define an open sided airflow chamber 136 of the nozzle. In use, when wheels 135 are in contact with a horizontal surface, the
10 nozzle 112 and the airflow chamber 136 extend generally horizontally, and preferably linearly along a nozzle axis 113 (see Figure 7).

[0047] An opening 138 is provided in the upper nozzle wall 126, and is in communication with the airflow chamber 136. Opening 138 may be of any size and configuration and at various locations in upper nozzle wall 126. In use, when
15 wheels 135 are in contact with a surface, the opening 138 faces a surface to be cleaned, air enters the dirty air inlet 118, passes horizontally through the airflow chamber 136, and passes into the opening 138. Opening 138 is in communication with a cyclone inlet passage 139, which is in communication with an air inlet 140 of cyclone 122.

20 [0048] Referring to Figures 5 and 6, cyclone 122 comprises a longitudinally extending sidewall 142. In the example shown, the longitudinally extending sidewall 142 is substantially cylindrical. The cyclone chamber is located inside chamber wall 142. The cyclone 122 extends along a longitudinal axis 123. Preferably, as shown, axis 123 is parallel to the nozzle axis, and
25 extends generally horizontally when cleaner 100 is in use and wheels 135 are seated on a surface.

[0049] Cyclone 122 further comprises an air inlet 140, and an air outlet 145. The cyclone air inlet and cyclone air outlet may be of any configuration

known in the art. The cyclone 122 further comprises an open end 147. The open end 147 comprises a dirt outlet 146 of the cyclone 122.

[0050] As exemplified, the cyclone air inlet 140 is defined by an aperture in the chamber wall 142. As can be seen in Figure 5, the inlet passage 139 is at
5 configured such that air enters the cyclone 122 in a tangential flow path, e.g., passage 139 may be arcuate. The air travels in a cyclonic path in the cyclone, and dirt in the air is separated from the air. The air exits the cyclone via an outlet passage 144, which is in communication with outlet 145. The dirt that is separated from the air exits the cyclone via dirt outlet 146 defined by open end
10 147, and enters dirt chamber 124.

[0051] As exemplified in Figure 6, a shroud 174 may be provided adjacent outlet passage 144, spaced from and facing the inlet 176 to outlet passage 144. Shroud 174 may be mounted to cyclone 122 via legs 178. In the example shown, shroud 174, and legs 178 form an assembly 182 that is removably
15 mounted in cyclone 122. In some examples, a screen may be mounted around legs 178. Shroud 174 may be of any design.

[0052] As noted hereinabove, the open end 147 of the cyclone 122 is in communication with a dirt chamber 124. In the example shown, dirt chamber 124 comprises two portions. A first portion 148 is provided forwardly of the dirt
20 outlet 146. A second portion 150 is concentric with the cyclone 122, and surrounds at least a portion of the cyclone 122. A lower portion 152 of the second portion 150 is below the cyclone. As exemplified, nozzle 112 is positioned below first portion 148, and lower portion 152.

[0053] Preferably, the surface cleaning apparatus comprises a plate 154
25 facing the open end 147 of the cyclone. Preferably, the plate 154 has a cyclone side 155 facing the open end 147, and a dirt bin side 157 facing front wall 158. The cyclone side 155 is preferably planar. For example, as exemplified, cyclone side may be oriented to be perpendicular to the cyclone axis 123. Preferably,

plate 123 is spaced for the open end of the cyclone. Preferably, the diameter of plate 154 and the diameter of the open end are about the same. The plate may be slightly smaller and/or slightly larger (e.g., +/- 10%).

[0054] As shown, plate 154 may be provided in the dirt chamber 124, and is spaced from a front wall 158 at the front 108 of the cleaner. Accordingly, the first portion 148 of dirt chamber 124 is provided between dirt bin side 157 of plate 154 and a front end wall 158 of the surface cleaning apparatus.

[0055] Preferably, the plate is positioned to define a gap 171 between the plate 154 and the open end 147 of the cyclone 122. More preferably, the gap has a variable length in the direction of the longitudinal axis 123 of the cyclone 122.

[0056] For example, as shown in Figures 5 and 6, the sidewall 142 of cyclone 122 has a variable length. That is, as shown, a first portion 184 of the sidewall 142 is longer than a second portion 186 of the sidewall. Accordingly, in this embodiment, the variable length of the sidewall of the cyclone provides the variable length of the gap.

[0057] In the embodiment shown, first portion 184 of the sidewall 142 has a first length L_{1A} , and second portion 186 of the sidewall 142 has a second length L_{2A} . Accordingly, the gap has a first length L_{1B} adjacent the first portion 184 of the sidewall, and a second length L_{2B} adjacent the second portion 186 of the sidewall. In the embodiment shown, the second length L_{2A} is greater than the first length L_{1A} . Accordingly, the first length L_{1B} of the gap 171 is greater than the second length L_{2B} of the gap 171.

[0058] Preferably, the first length L_{1A} of the first portion 184 and the first length L_{2A} of the second portion are constant. More preferably, the first length L_{1B} of the gap 171 and the second length L_{2B} of the gap 171 are constant. In alternate embodiments, however, one or both of the first length L_{1B} of the gap 171 and the second length L_{2B} of the gap 171 may be variable.

[0059] In the exemplified embodiment, sidewall 142 has a first end 188 at open end 147, and a second end 190 opposed to the first end. The first end has a perimeter. Preferably, in embodiments wherein the first length L_{1A} and the second length L_{2A} are constant, one of first portion 184 and second portion 186 extends up to 210° of the perimeter. For example, the first portion 184 may extend up to 210° of the perimeter. For example, as shown, first portion 184 extends for about 180° of the perimeter (indicated by arrow P_1) and the second portion 186 extends for about 180° of the perimeter (indicated by arrow P_2).

[0060] In alternate embodiments, wherein the first length L_{1A} and/or the second length L_{2B} are variable, one of first portion 184 and second portion 186 preferably extends up to 240° of the perimeter. For example, the first portion may comprise 240° of the perimeter, and the second portion may comprise 120° of the perimeter. In such an embodiment, the face of the wall facing the open end of the cyclone may extend upwardly at an angle.

[0061] It will be appreciated that in alternate embodiments, a cyclone 122 having a variable length may be useful, even if a plate 154 is not provided.

[0062] Alternately or in addition, as exemplified in Figures 9 and 10, the plate 154 may have a plate sidewall 153 extending towards the open end 147. Preferably, the plate sidewall 153 is at the periphery of the plate. In the embodiment shown, the plate sidewall 153 extends part way around the plate 154. Accordingly, in this embodiment, the space between the plate sidewall and the open end of the cyclone defines the variable length of the gap, and gap 171 has a first length L_{1B} between the plate 154 and the end 188 of cyclone 122, and a second length L_{2B} between the sidewall 153 and the end 188 of cyclone 122 that is less than the first length L_{1B} .

[0063] In some embodiments, as shown, the sidewall 153 of the plate 154 has a constant length.

[0064] In alternate embodiments, the plate sidewall 154 may extend all the way around the plate 154, and may have a variable length.

[0065] Plate 154 may be mounted by any means to any component in cyclone unit 114. As exemplified, the separation plate is mounted on an arm 156,
5 which extends from a front wall 158 at the front 108 of the cleaner 100.

[0066] Cyclone unit 114 may be emptied by any means known in the art. For example, one of the ends of the cyclone unit 114 may be openable. As exemplified in Figures 4 and 5, front wall 158 is pivotably mounted to the cyclone unit wall 115, such that cyclone unit 114 may be opened, and dirt chamber 124
10 may be emptied. When front wall 158 is pivoted away from the remainder of the cyclone unit 114, separation plate 154 and arm 156 also pivot away from the remainder of the cyclone unit. A latch 159 is provided, which secures front wall 158 to wall 115. In alternate examples, front wall 158 may be removable from cyclone unit wall 115 or the opposed end of the cyclone unit 114 may be
15 openable.

[0067] The clean air exiting cyclone 122 passes through outlet passage 144, exits surface cleaning head 116, and passes into the cleaner body 160. The air exiting the cyclone may be subjected to one or more treatment stages (e.g., cyclonic and/or filtration). In the example shown, a cleaner body 160 is
20 positioned rearward of the surface cleaning head 116. The cleaner body comprises a housing 161, which preferably houses an optional pre-motor filter assembly 162, a suction motor 164, and an optional post-motor filter 166.

[0068] In the exemplified embodiments, the vacuum cleaner has a linear configuration. Accordingly, pre-motor filter assembly 162 is preferably provided in
25 the airflow path adjacent and downstream of the outlet passage 144. Pre-motor filter assembly 162 serves to remove remaining particulate matter from air exiting the cyclone 122, and may be any type of filter, such as a foam filter. One or more filters may be used, as shown. If the vacuum cleaner is of a non-linear

configuration, then pre-motor filter assembly 162 need not be located adjacent outlet passage 144.

5 [0069] Suction motor 164 is provided in the airflow path preferably adjacent and downstream of the pre-motor filter 162. The suction motor draws air into the dirty air inlet 118 of the cleaner 100, through the airflow path past the suction motor 164, and out of the clean air outlet 120. The suction motor 164 has a motor axis 165. In the example shown, the motor axis 165 and the cyclone axis 122 extend in the same direction and are generally parallel. The suction motor 164 may be any type of suction motor. If the vacuum cleaner is of a non-
10 linear configuration, then motor 164 need not be located adjacent pre-motor filter 162.

[0070] Post motor filter 166 is provided in the airflow path downstream of, and preferably adjacent, the suction motor 164. Post motor filter serves to remove remaining particulate mater from air exiting the cleaner 100. Post-motor
15 filter 166 may be any type of filter, such as a HEPA filter.

[0071] Clean air outlet 120 is provided downstream of post-motor filter 166. Clean air outlet 120 comprises a plurality of apertures preferably formed in housing 161.

[0072] Preferably, as in the example shown, cleaner body 160 is
20 removably mounted to surface cleaning head 116. For example, cleaner body 160 may be entirely removable from surface cleaning head 116, or pivotably mounted to surface cleaning head 116. Accordingly, cleaner body 160 and surface cleaning head 116 may be separated in order to provide access to the interior of cleaner body 160 or surface cleaning head 116. This may allow pre-
25 motor filter assembly 162 to be cleaned, changed, or serviced, or motor 164 to be cleaned, changed or serviced. Alternately, or in addition, surface cleaning head 116 may be cleaned or serviced. For example, any dirt stuck in outlet passage 144 may be removed. Alternately, a replacement cleaner body 160 or

surface cleaning head 116 may be provided, and may be mounted to an existing surface cleaning head 116 or cleaner body 160, respectively. If no filter element is fixedly mounted to cleaning head 116, then cleaning head 116 may be removed and washed with water.

- 5 [0073] As can be seen in Figure 6, housing 161 preferably comprises a first portion 168 housing pre-motor filter assembly 162, and suction motor 164, and a second portion 170 housing post-motor filter 166. Second portion 170 is openable, such as by being removably mounted to first portion 168, such that post-motor filter 166 may be cleaned, changed, or serviced.
- 10 [0074] One or more additional rear wheels 180 may be mounted to housing 161, preferably at lower portion 106, and may be used in conjunction with wheels 135. Preferably, a single rear wheel 180 is provided. Preferably, rear wheel 180 is located on a centre line of the vacuum cleaner and rearward of the depending wall 128.
- 15 [0075] As mentioned hereinabove, surface cleaning apparatus 100 is a preferably a portable vacuum cleaner 100, as shown in Figures 1 to 7.

CLAIMS:

1. A surface cleaning apparatus comprising:
 - 5 (a) an air flow passage extending from a dirty air inlet to a clean air outlet;
 - (b) a suction motor positioned in the air flow passage;
 - (c) a cyclone positioned in the air flow passage, the cyclone comprising an air inlet, an air outlet, an open end, a longitudinal axis and a longitudinally extending sidewall;
 - 10 (d) a plate having a cyclone side facing the open end, the plate positioned to define a gap between the plate and the open end of the cyclone wherein the gap has a variable length in the direction of the longitudinal axis; and,
 - (e) a dirt collection chamber in flow communication with the open end.
- 15 2. The surface cleaning apparatus of claim 1 wherein the sidewall of the cyclone has a variable length.
3. The surface cleaning apparatus of any of claims 1-2 wherein the plate has a plate side wall extending towards the open end and the side wall extends part
20 way around the plate.
4. The surface cleaning apparatus of claim 3 wherein the sidewall of the plate has a constant length.
- 25 5. The surface cleaning apparatus of claim 4 wherein the sidewall of the plate has a variable length.
6. The surface cleaning apparatus of any of claims 1-5 wherein the sidewall of the cyclone has a first end at the open end, the first end has a perimeter, the

gap has a first portion having a first length and a second portion having a second length greater than the first length, and the first length and the second length are constant.

5 7. The surface cleaning apparatus of claim 6 wherein one of the portions extends up to 210° of the perimeter.

8. The surface cleaning apparatus of claim 7 wherein the second portion extends up to 210° of the perimeter.

10

9. The surface cleaning apparatus of any of claims 1-5 wherein the sidewall of the cyclone has a first end at the open end, the first end has a perimeter, the gap has a first portion having a first length and a second portion having a second length, and the first length is variable.

15

10. The surface cleaning apparatus of claim 9 wherein the second portion extends up to 240° of the perimeter.

11. A surface cleaning apparatus comprising:

20

(a) an air flow passage extending from a dirty air inlet to a clean air outlet;

(b) a suction motor positioned in the air flow passage;

(c) a cyclone positioned in the air flow passage, the cyclone comprising an air inlet, an air outlet, an open end, a longitudinal axis and a longitudinally extending sidewall, the side wall having a variable length; and,

25

(d) a dirt collection chamber in flow communication with the open end.

12. The surface cleaning apparatus of claim 11 wherein a first portion of the sidewall is longer than a second portion of the sidewall.

13. The surface cleaning apparatus of claim 12 wherein the sidewall has a first end at the open end, the first end has a perimeter and the first portion comprises up to 240 degrees of the perimeter and the second portion comprises from up to 120 degrees of the perimeter.
- 5
14. The surface cleaning apparatus of any of claims 11-13 further comprising a plate facing the open end.
15. The surface cleaning apparatus of claim 14 wherein the plate is spaced from
10 a front end wall of the surface cleaning apparatus.
16. The surface cleaning apparatus of claim 15 wherein a first portion of the dirt collection chamber is provided between the plate and the front end wall.
- 15 17. The surface cleaning apparatus of any of claims 15-16 wherein a second portion of the dirt collection chamber surrounds at least a portion of the cyclone.
18. A surface cleaning apparatus comprising:
- 20 (a) an air flow passage extending from a dirty air inlet to a clean air outlet;
- (b) a suction motor positioned in the air flow passage;
- (c) a cyclone positioned in the air flow passage, the cyclone comprising an air inlet, an air outlet, an open end, a longitudinal axis and a longitudinally extending sidewall;
- 25 (d) a plate having a cyclone side facing the open end, the plate positioned to define a gap between the plate and the open end of the cyclone, the plate having a plate sidewall extending towards the open end; and,
- (e) a dirt collection chamber in flow communication with the open end.

19. The surface cleaning apparatus of claim 18 wherein the plate sidewall extends part way around the plate.
20. The surface cleaning apparatus of any of claims 18-19 wherein the sidewall of
5 the plate has a constant length.
21. The surface cleaning apparatus of any of claims 18-19 wherein the sidewall of the plate has a variable height.
- 10 22. The surface cleaning apparatus of any of claims 1-21 wherein the surface cleaning apparatus comprises a portable vacuum cleaner.
23. The surface cleaning apparatus of claim 22 wherein the portable vacuum cleaner is removably mountable to an upright vacuum cleaner.
15
24. The surface cleaning apparatus of any of claims 1-23 wherein the surface cleaning apparatus comprises a hand vacuum cleaner.

20

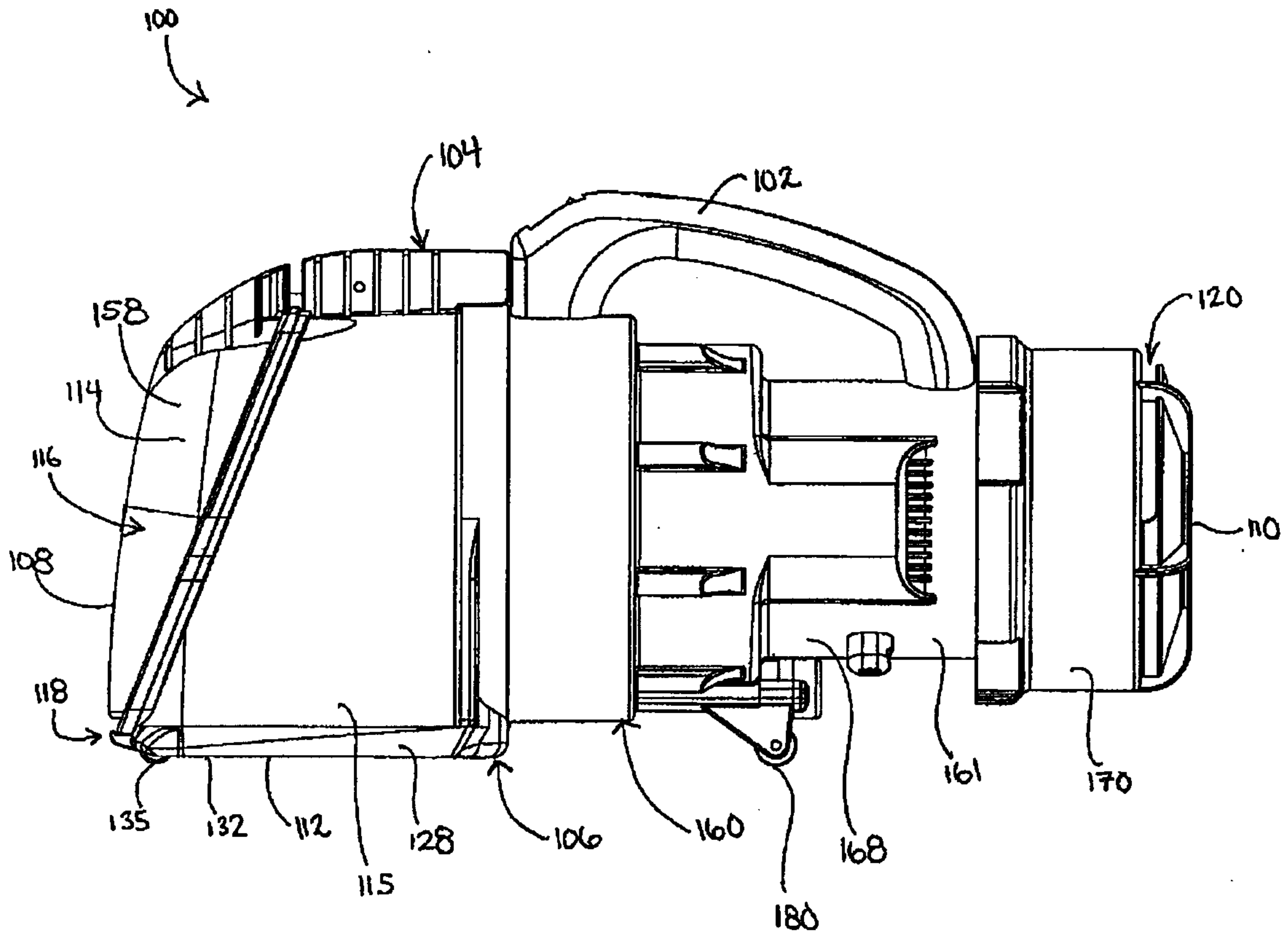

FIG. 1

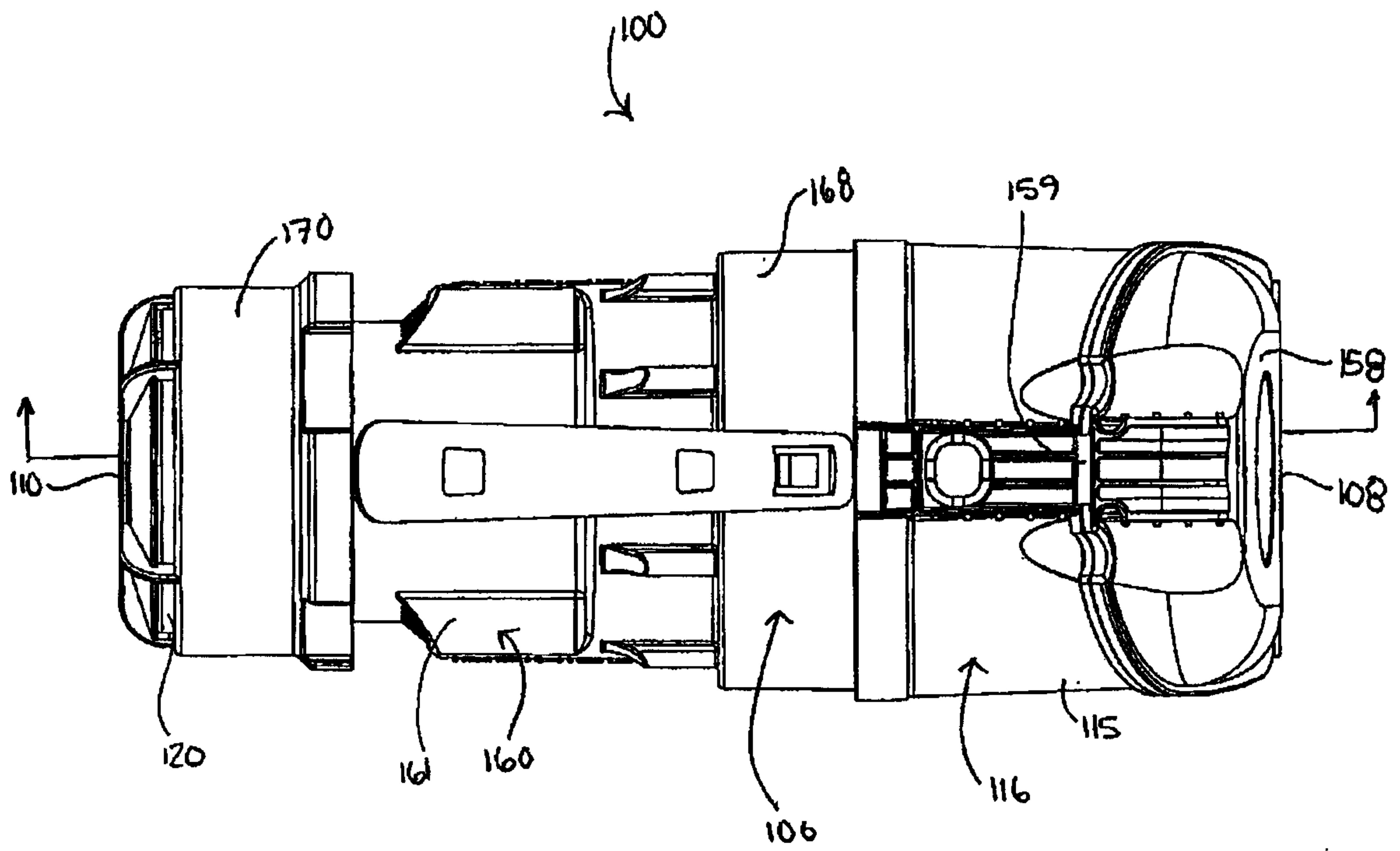

FIG. 2

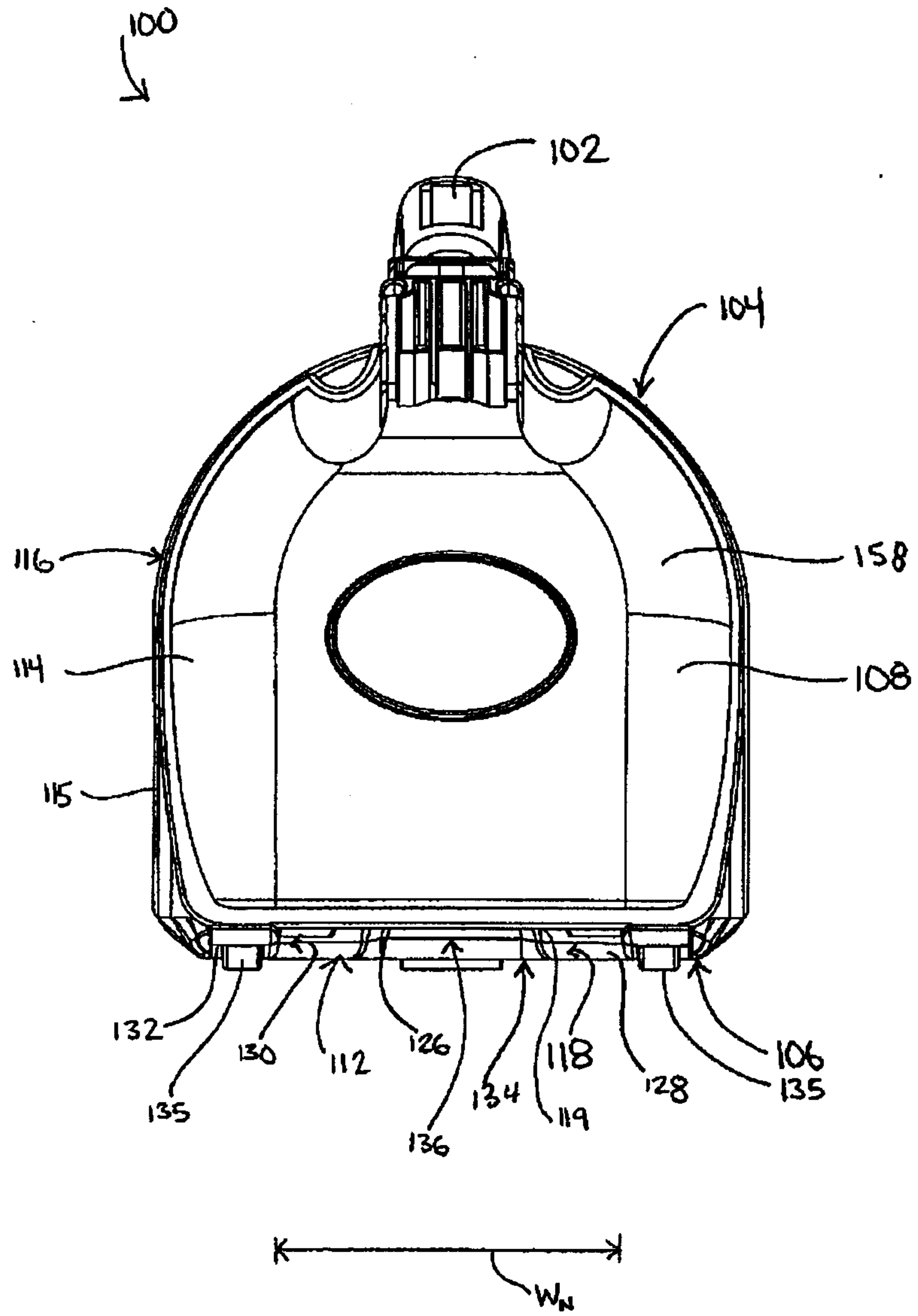

FIG. 3

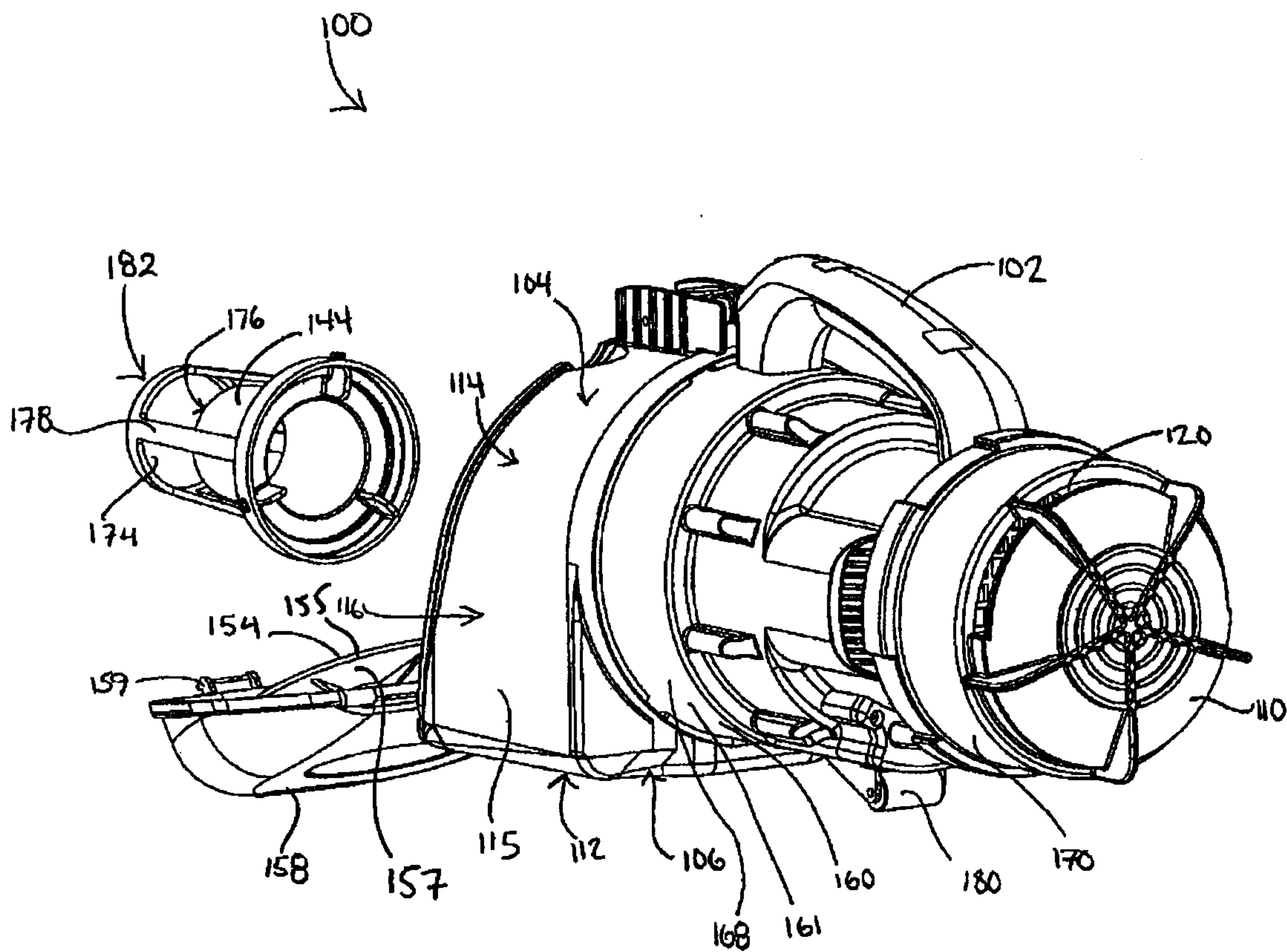

FIG. 4

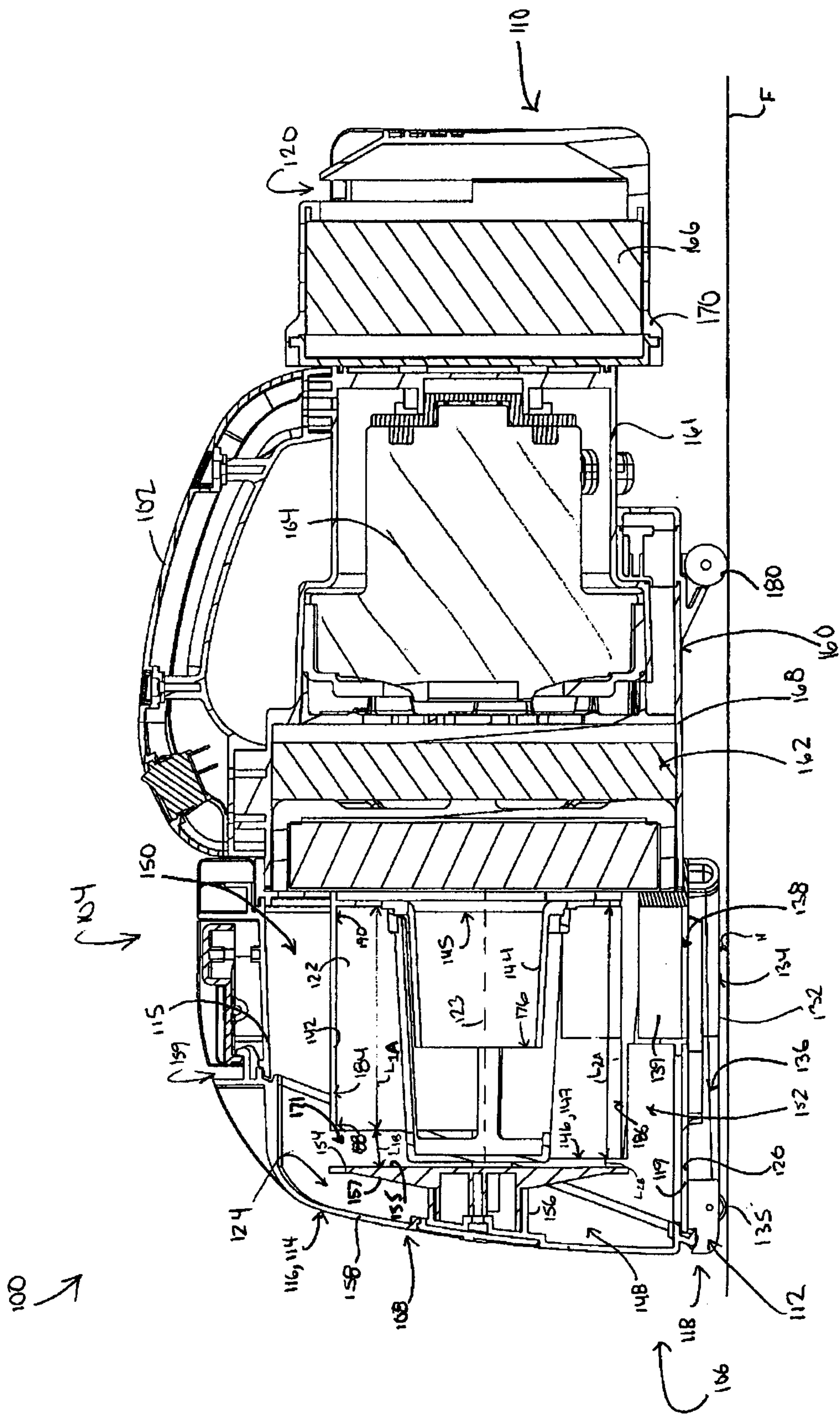

Fig. 6

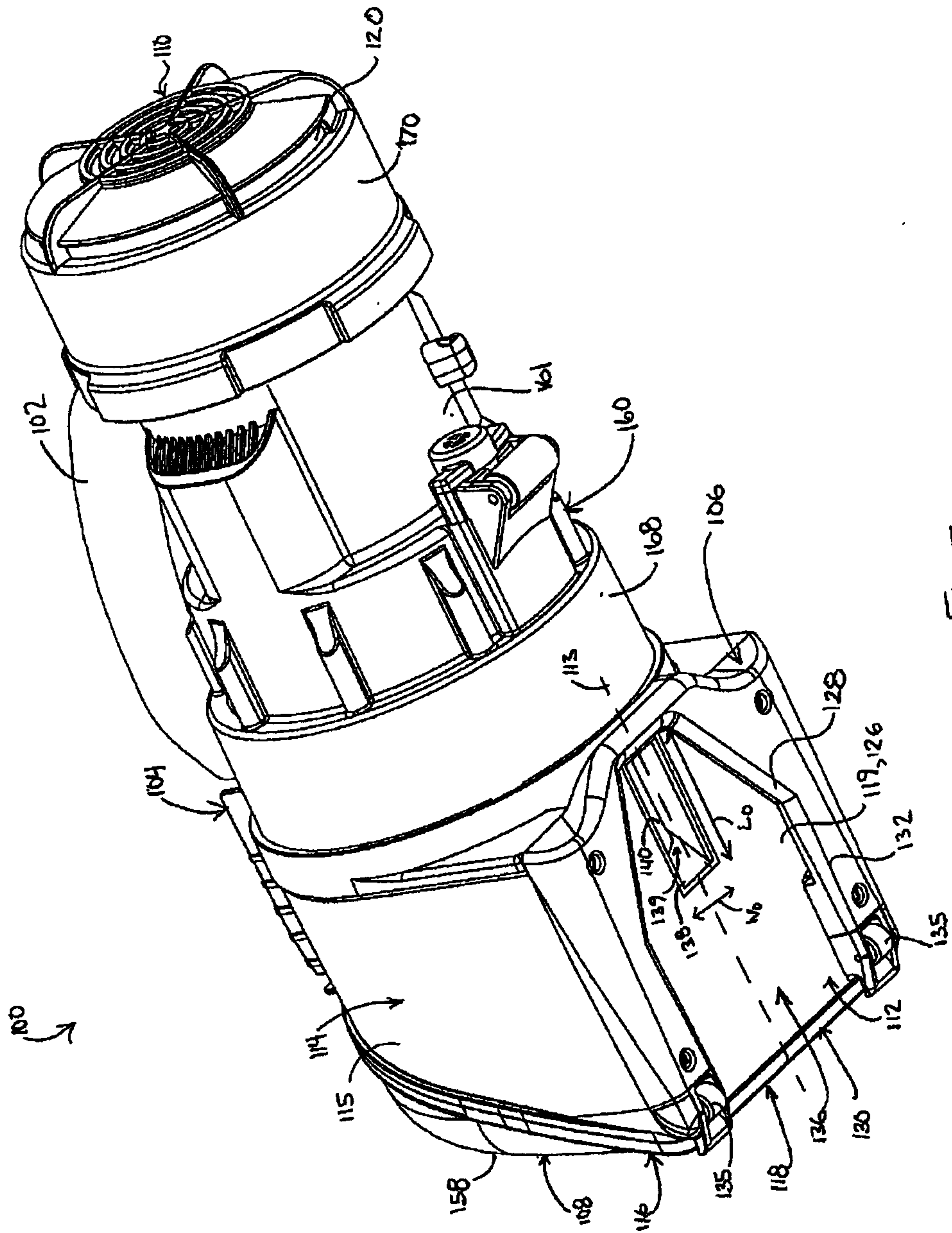

Fig. 7

