

T. H. Witherby,
Shearing and Punching Machine
N^o 10,339. Patented Mar. 29, 1870.

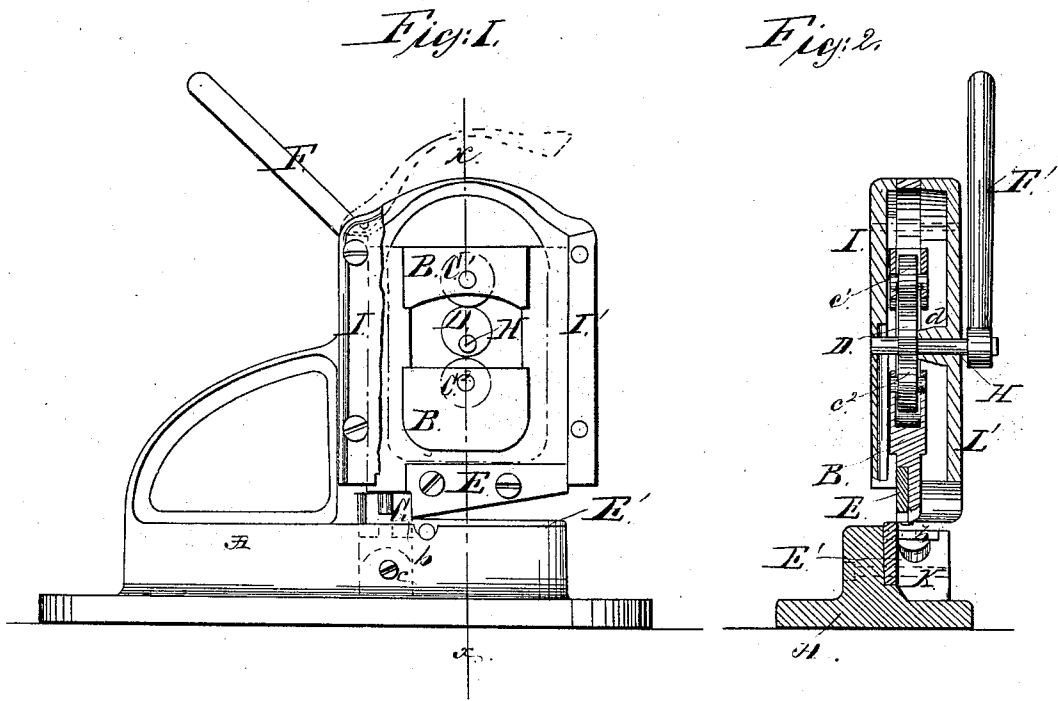

Witnesses:
G. Mathys
B. James

Inventor:
Thomas H. Witherby

United States Patent Office.

THOMAS H. WITHERBY, OF WORCESTER, MASSACHUSETTS.

Letters Patent No. 101,339, dated March 29, 1870.

IMPROVED SHEARING AND PUNCHING-MACHINE.

The Schedule referred to in these Letters Patent and making part of the same.

To all whom it may concern:

Be it known that I, THOMAS H. WITHERBY, of the city and county of Worcester and State of Massachusetts, have invented a new and useful Improvement in Cutting-Shears and Punch; and I do hereby declare the following to be a full, clear, and exact description of the same in its construction and operation, reference being had to the annexed drawings making a part of this specification, in which—

Figure 1 is a side view, showing the interior and working parts of my invention, and

Figure 2 is a vertical sectional view of fig. 1 through a line drawn from $x x$ therein.

The nature of my invention consists in the arrangement of the operative parts of the device claimed in a compact position within the case I, which case and the standard A are cast in one piece, and composed of metal.

Projections are formed within the case I, against which the sliding frame B B abuts, having a space between said frame and the main portion of the said case.

This frame B B is also cast in one piece, containing within it the cores or slots, within which are placed the wheels $c' c'$, which are pivoted at 1 1, in fig. 1.

To the lower end of the frame B B the cutting-edge or cutter E is securely fastened by screws or other suitable manner, a portion of the frame, of nearly the width of the cutter, being cut away to admit of its insertion, which space is produced at the time of casting the frame.

On one side of said frame the punch G is attached, projecting sufficiently far below the frame to perform the functions designed for it.

A stud or projection, d , is formed upon the inner side of the case I, through which a shaft, H, passes, the outer side of which is attached to the arm F, and to its inner side, within the case, is attached the cam D, so placed upon the shaft that when the covering or shield I is screwed to the case I, the cam D will move within the frame B B, between the wheels c' and c' , moving the frame either upward or downward, as the arm F is raised or depressed. The shaft H enters into the covering I, which aids in retaining it in its proper position.

A counterpart of the cutter E is securely fastened to the base A, as seen at E', figs. 1 and 2.

A hole, a , may be placed within the cutter E, and a corresponding depression made in the frame A, so that wire may be inserted to be cut.

This cutting-edge or cutter E' is securely fastened to the part A by screws, or in any other suitable manner.

K is a metallic block, containing a depression or groove upon its upper surface, above which is placed the cap b , the latter containing within it a hole sufficiently large to admit of the reception of the punch G. This block K is firmly secured to the main part of the frame A by screw or screws c .

By this mode of construction, the metal cut can be punched at one and the same movement of the machine, or separately, as desired.

By this mode of construction great power is obtained, and the operative parts of the device are compactly arranged, and the parts thereby easily duplicated when broken or injured.

In order to have access to the inner side of the case inclosing the frame B B, and the wheels and cam placed therein, for the purposes of lubrication, I leave a space between the two parts of the case I and I', as seen at the top thereof, to be filled by a lid or cover, pivoted or hinged to the back part of the case, which lid can be easily removed for the purposes specified.

A lug is also formed on the inner side of the front and removable portion of the case, corresponding to and with the one formed on the inner side of the outer case, to receive the end of the shaft to which the cam D is rigidly attached, thereby forming a strong and secure support to the shaft aforesaid.

What I claim as my invention, and desire to secure by Letters Patent, is—

1. As an improvement in machines for cutting metal, the perforations a in the lower shear-blade, by virtue of which the machine is adapted to shear sheet or plate metal, and also to cut rods or bars, in the manner and for the purpose herein described.

2. The arrangement, as herein described, of the frame B and anti-friction rolls, the eccentric D, shears E E and punch, and die G and b , for the purposes herein set forth.

THOMAS H. WITHERBY.

Witnesses:

B. F. JAMES,
G. MATHYS.