

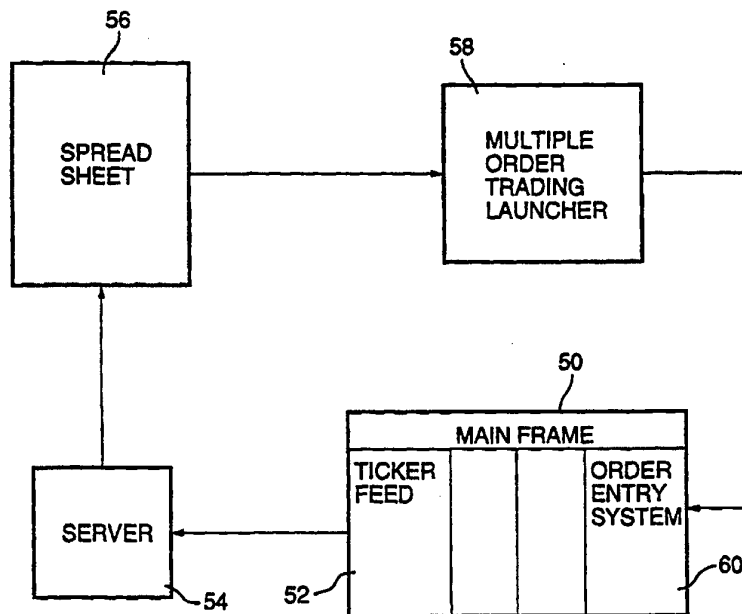

INTERNATIONAL APPLICATION PUBLISHED UNDER THE PATENT COOPERATION TREATY (PCT)

<p>(51) International Patent Classification ⁶ : G06F 17/60</p>	<p>A1</p>	<p>(11) International Publication Number: WO 95/26005 (43) International Publication Date: 28 September 1995 (28.09.95)</p>
<p>(21) International Application Number: PCT/CA95/00123 (22) International Filing Date: 3 March 1995 (03.03.95) (30) Priority Data: 2,119,921 23 March 1994 (23.03.94) CA (71)(72) Applicant and Inventor: BELZBERG, Sydney, H. [CA/CA]; Suite 5707, 40 King Street West, Toronto, Ontario M5H 3Y2 (CA). (74) Agent: SHEARN, G., James, M.; Suite 4300, Scotia Plaza, 40 King Street West, Toronto, Ontario M5H 3Y4 (CA).</p>	<p>(81) Designated States: AM, AT, AU, BB, BG, BR, BY, CH, CN, CZ, DE, DK, EE, ES, FI, GB, GE, HU, JP, KE, KG, KP, KR, KZ, LK, LR, LT, LU, LV, MD, MG, MN, MW, MX, NL, NO, NZ, PL, PT, RO, RU, SD, SE, SG, SI, SK, TJ, TT, UA, UG, US, UZ, VN, European patent (AT, BE, CH, DE, DK, ES, FR, GB, GR, IE, IT, LU, MC, NL, PT, SE), OAPI patent (BF, BJ, CF, CG, CI, CM, GA, GN, ML, MR, NE, SN, TD, TG), ARIPO patent (KE, MW, SD, SZ, UG).</p> <p>Published <i>With international search report. Before the expiration of the time limit for amending the claims and to be republished in the event of the receipt of amendments.</i></p>	

(54) Title: COMPUTERIZED STOCK EXCHANGE TRADING SYSTEM



(57) Abstract

An improvement in computer automated stock exchange trading whereby a graphic user interface with a mouse and display is used to select parameters such as share symbol, price selection, order size, and transaction type, as well as other indicators to launch a trading order to the order entry system of a stock exchange computer. Further improvements include a programmed interface by which data on a group of shares may be read from a spreadsheet formulated into an order and launched automatically or in response to a signal from an operator so as to trade an index or basket of shares substantially instantaneously.

FOR THE PURPOSES OF INFORMATION ONLY

Codes used to identify States party to the PCT on the front pages of pamphlets publishing international applications under the PCT.

AT	Austria	GB	United Kingdom	MR	Mauritania
AU	Australia	GE	Georgia	MW	Malawi
BB	Barbados	GN	Guinea	NE	Niger
BE	Belgium	GR	Greece	NL	Netherlands
BF	Burkina Faso	HU	Hungary	NO	Norway
BG	Bulgaria	IE	Ireland	NZ	New Zealand
BJ	Benin	IT	Italy	PL	Poland
BR	Brazil	JP	Japan	PT	Portugal
BY	Belarus	KE	Kenya	RO	Romania
CA	Canada	KG	Kyrgystan	RU	Russian Federation
CF	Central African Republic	KP	Democratic People's Republic of Korea	SD	Sudan
CG	Congo	KR	Republic of Korea	SE	Sweden
CH	Switzerland	KZ	Kazakhstan	SI	Slovenia
CI	Côte d'Ivoire	LI	Liechtenstein	SK	Slovakia
CM	Cameroon	LK	Sri Lanka	SN	Senegal
CN	China	LU	Luxembourg	TD	Chad
CS	Czechoslovakia	LV	Latvia	TG	Togo
CZ	Czech Republic	MC	Monaco	TJ	Tajikistan
DE	Germany	MD	Republic of Moldova	TT	Trinidad and Tobago
DK	Denmark	MG	Madagascar	UA	Ukraine
ES	Spain	ML	Mali	US	United States of America
FI	Finland	MN	Mongolia	UZ	Uzbekistan
FR	France			VN	Viet Nam
GA	Gabon				

COMPUTERIZED STOCK EXCHANGE TRADING SYSTEM

This invention relates to automated means for effecting the purchase and sale of shares traded on a stock exchange. More particularly, it relates to computer software and hardware by which an operator may instantaneously effect the transfer of shares of a large number of corporations.

BACKGROUND:

For many years the trading of shares listed on a stock exchange were effected by the activities of people known as traders on the trading floor of a stock exchange, and were confirmed by some form of notation or writing on paper. Once effected, the trades or transfers of shares were formally reported to brokers for the purchasing and selling customers in a formal way with or without the delivery of the share certificates.

More recently the transactions have become automated so that trades may be done by a trader operating a keyboard to enter the necessary commands into a terminal connected to the mainframe computer of the stock exchange, or a small personal computer with a terminal emulator. With this automated system a trader may enter an order to buy or sell which is transmitted to the central system of the stock exchange where it matched with another trader who is willing to sell or buy the same shares, and the computer then confirms the completion of the transaction to each trader, and the transaction is confirmed and recorded by means of a hard copy generated on a printer.

Although this computerized automated system was much faster than the trading floor, it still required a trader to key in by hand the necessary data and commands for each

individual stock being traded. From the information available at a terminal, the trader/operator would have to input the symbol for the company shares, the price, the exchange, the size of the order, and the instructions to buy, sell, cross
5 or short trade the stock.

It has even become possible to effect trades in certain stocks automatically when they reach a certain price level.

However, modern investment strategies involve
10 the investment in large groups or "basket" of listed shares as part of an entire portfolio which is strategically selected to provide a balance of growth potential, income generation, and risk avoidance. These portfolios are often held by mutual funds, banks, insurance companies, or other institutional
15 investors, and they are frequently being changed to adjust the balance in the factors which effect growth, income and risks.

Some institutions invest in an established mixture of stocks which reflect the current economic climate in the country, such as the TSE 35, the TSE 100, the TSE 300, and in the United States the Dow Jones or other representative 5 portfolios. In some cases institutional investors will establish their own collection of shares which it considers to represent their investment strategy and objectives. These may be weighted in favour of industry groups such as mining companies, financial institutions, manufacturing, or others 10 considered preferable by the investment manager.

As a result of this strategy of investing in a mixed "basket" of shares, institutional investors are often increasing or decreasing their investment in the entire range of shares in a basket or index. This therefore requires 15 a large number of trades in order to effect the single

investment move. Hitherto, this has been done by a trader/operator keying in the necessary trades in each individual stock through a computer terminal. Where the portfolio includes a list of 100 stocks, for example, this is a lengthy process and in fact the problem arises that the prices of many shares would change during the time it takes to key in the various orders, and the original conditions necessary to satisfy the requirements of the particular trade may no longer be present.

10 SUMMARY OF THE INVENTION:

It is therefore the purpose of the present invention to provide an automated, computerized trading system in which multiple share order entries can be executed automatically within seconds by the trader/operator in activating a few entries on a keyboard. This method of

trading is accomplished by means of the present invention
in which a list of stocks is continually monitored and their
prices recorded on a "spreadsheet format" on a personal
computer and displayed on a screen. When the composite price
5 of the list of stocks conforms to certain predetermined
parameters, the trader can execute the necessary instructions
to transform the list into an order on the personal computer
(which is connected to the computerized order entry system
of the stock exchange, which may be a mainframe), and the
10 order will be immediately processed by the computer and sent
to the exchange's order entry system. Thus, the purchase
or sale of a basket comprising various numbers (volumes)
of a variety of shares can be executed in a matter of seconds
before the price or other conditions have changed.

15

By means of the system programmed in accordance with the present invention, a conventional terminal or personal computer capable of communication with a stock exchange central computer can be adapted to read, process, and react to information from the stock exchange, and/or commands of the operator and automatically and quickly perform multiple trades in a manner described above.

DESCRIPTION OF THE PREFERRED EMBODIMENT:

The invention may be better understood by a description of one embodiment with reference to the attached drawings in which:

Figure 1 is a schematic illustration of a mainframe stock exchange computer to which a series of terminals or personal computers are connected each comprising a display screen and keyboard;

Figure 2 is a graphic user interface suitable
for use in executing single stock trans-
actions;

5 Figure 3 is a graphic user interface used in
effecting multiple trades in a basket
comprising various volumes of a list of
shares;

10 Figure 4 is a schematic block diagram which
illustrates the sequence and flow of
data and commands by which the system
is used.

In the system illustrated in the attached drawings
Figure 1 shows a mainframe computer 2 used to process all
the data relating to the stocks listed on a stock exchange,
15 such as the TSE, the VSE, or the NYSE, as the case may be.

Since the advent of computerized trading, these mainframe
central computers are connected to a variety of terminals,
such as 4, in various trading offices of brokerage houses
through the city and abroad. By means of the individual
5 terminals, traders may review data on the display screen
8 and input the necessary information and instructions on
the keyboard 6 whereby a given volume of a particular stock
is bought or sold (or crossed or shorted) in a manner which
is the automated equivalent of an individual transaction
10 on the trading floor.

Such a network is referred to, in the case of
the Toronto Stock Exchange, as "CATS" which is an
abbreviation for "Computer Aided Trading System", and similar
systems are now commonly used and operated by many stock
15 exchanges.

Figure 2 illustrates an improvement which comprises a graphic user interface with a network such as CATS which allows a trader/operator to use the trading system more quickly and efficiently.

5 Whereas previously the data necessary for a transaction (stock symbol, volume, price, buy or sell, etc., etc.) had to be entered on the keyboard and showed up in the screen area 10 before the order could be launched to the central processing unit, the present invention allows
10 the instructions to be put in much more quickly, more easily and with less error.

In the embodiment illustrated in Figure 2, the trader/operator can enter the symbol representing the stock in the area 12 followed by the price at which the transaction
15 is to be completed in space 14 (which may be a selected price

or the bid offer or last price derived from the CATS data).
Then the size of the order (or volume of the transaction)
may be indicated in space 16 by selecting the appropriate
nominal figures 1,000, 5,000, 10,000, 50,000 or by
5 inserting the precise volume in the box 18. Many of the
instruction choices provided by this interface (such as bid,
offer, last, ID, volume, exchange, transaction) may be entered
without keying by using a mouse as illustrated at 10 in Figure
1, which directs a cursor or indicator to the command.

10 In the illustrated embodiment the other information
may be selected, such as the appropriate exchange in area
20, the type of transaction in area 22, the buy and sell
IDs in areas 24 and 26. Other areas 28 provided by the
interface include features to provide various information
15 from the data bank as an aid to the operator.

To effect individual transactions an operator may, by mouse or a combination of mouse and keyboard, enter the necessary data and commands and quickly transmit the transaction to a stock exchange.

5 Thus, by means of the interface illustrated in Figure 2, transactions of a single stock through a computer aided trading system may be more quickly and efficiently executed.

10 The second aspect of the present invention is illustrated in Figure 3 which is a reproduction of a display screen which is part of the multiple stock trading system.

 By means of the software of this invention, the terminal or personal computer illustrated in Figure 1 can
15 be used to connect the spreadsheet of the system to the data base of the stock exchange mainframe and display the

information (including symbol, volume of shares, bid, first
and last price) in the area 30 of the display screen of the
terminal as shown in Figure 3. For purposes of trading
an index or custom basket of shares, the display will contain
5 the information with respect to the shares included in the
index or basket as illustrated. The system then executes
a dynamic data link to the spreadsheet which causes the
spreadsheet to read the list of stocks to the multiple order
trading system of the present invention. In the next step
10 the system captures the spreadsheet data and makes each stock
price and volume a variable that is inserted in a list of
preprogrammed commands. The list is then sent to the order
entry system of the stock exchange with a single key stroke.

Thus, each of the stocks and the pertinent data
15 relating thereto is entered into the multiple order entry

system, and at the appropriate time and with the appropriate command, the entire basket can be dealt with in a single transaction within a matter of seconds before prices or other criterion change.

5 The present system therefore eliminates the need for a trader/operator to enter each individual stock and the transaction criterion, which in the case of 100 stocks or so, would be time-consuming, prone to error, and difficult to coordinate because of the changing prices and their
10 relationship to the transaction criterion.

Also illustrated in Figure 3 is a box 32 in which the necessary commands may be entered from a keyboard.

Also illustrated, in area 34, is a series of commands which may be quickly entered by means of a mouse
15 or similar device, including identification of the basket

of shares to be traded 36, the type of transaction (buy, sell, cross, or sell short) 38, the appropriate buy ID 40 or sell ID 42, and the price (bid, offer, or last) 44. When the appropriate commands have been entered the transaction
5 may be executed by pressing the launch button 46 and all of the shares of the basket are traded almost instantaneously.

As in all cases a provision is made for the entry of a pass word 48 to provide security against unauthorized use and other functions which are commonly associated with
10 graphic user interface are provided.

Therefore, by means of the present system, a terminal or personal computer may be used to capture from a spreadsheet all the data necessary to trade in a selected list or group of shares, and by inserting this data into
15 the preprogrammed commands of the system, all of the necessary commands to execute the trade in all of the shares may be sent to the stock exchange order entry system in a single set of signals.

It will be appreciated that this system will enable a trader to deal in baskets of shares, whether they are related to a standard index, such as the TSE 35 or the TSE 100, or a customized basket of shares designed for or by each customer and will be able to effect transactions quickly and without the complications that arise from the time delay in entering each stock transaction separately.

Figure 4 is a block diagram and flow chart which illustrates schematically how the present invention facilitates a faster more efficient operation of the automated trading facilities. In the diagram the mainframe or central computer of the stock exchange is shown at 50 and includes a ticker feed system 52 which constantly generates updated data on the prices and volumes of various stocks being traded, and delivers the updated data to a server 54 where the data

is stored and accessible to any terminals which are connected to the network. The information in the server is read by the spreadsheet 56 of a terminal, such as the one illustrated in Figure 1, which is designed to read and display a given
5 basket of shares with the pertinent data with respect to volumes, bid, offer, last, etc. Block 58 represents the multiple order trading system of the present invention which reads the data from the spreadsheet, including all the data on a given basket of shares, organizes the data into the
10 proper format for automated trading, and issues the multiple orders to the order entry system 60 of the central computer 50 at the stock exchange.

By having the data formatted by the multiple order launcher, the transaction of a whole basket of shares can
15 be effected quickly, easily, with fewer errors and within the time frame for which the criterion or instructions for the transaction are valid.

By providing a means, such as the multiple order launcher, which is capable of capturing all the data on a spreadsheet, selecting what is required, and organizing it into the form of an order, the present invention creates
5 a bridge between the spreadsheet, which contains the necessary data on a group of stocks, and the order entry system of the stock exchange which effects a transaction in those stocks.

Furthermore, because it can use and format the
10 data more quickly and correctly than an operator on a keyboard, it is capable of effecting a transaction within the time and parameters which are rapidly changing, in a manner which an operator could not accomplished. Therefore, instead of merely processing data, it is capable of activating
15 and controlling stock transactions. In this respect the

system may be adapted to initiate a transaction automatically when certain criterion are met, or may be designed to create a signal when the criterion are met so that a trader/operator may make the final decision or judgment to execute the transaction or not, and may then execute it substantially instantaneously once the decision has been made.

Once the order entry has been received by the exchange system, the transaction is completed and the appropriate records and confirmation documents are produced in the usual manner without any further activity by the trader.

It will, of course, be realized that numerous modifications and variations from the illustrated embodiments may be employed without departing from the inventive concept herein.

CLAIMS:

The embodiments of the invention in which an exclusive property or privilege is claimed are defined as follows:

1. For use in a computer system having means to receive data from a central computer of a stock exchange on a spreadsheet; - display means and means to communicate orders to the order entry system of the stock exchange computer;
 - a control system comprising means to read selected groups of said data from said spreadsheet;
 - means to formulate said data in a manner acceptable to the stock exchange computer or entry system;
 - means to launch said orders to the stock exchange computer order entry system.

2. A control system as claimed in claim 1 wherein said means to launch is responsive to conditions in the data read from said spreadsheet.

3. Apparatus as claimed in claim 2 wherein said means to launch said order is responsive to the commands of an operator.

4. Apparatus as claimed in claims 1, 2 and 3 wherein said means to read, means to formulate, and means to launch are operated by means of a graphic user interface with display means and a mouse adapted to communicate to selected controls on the graphic user interface display.

5. A system as claimed in claim 4 in which said graphic user interface displays commands which include share symbols, price selections, order size, and transaction type.

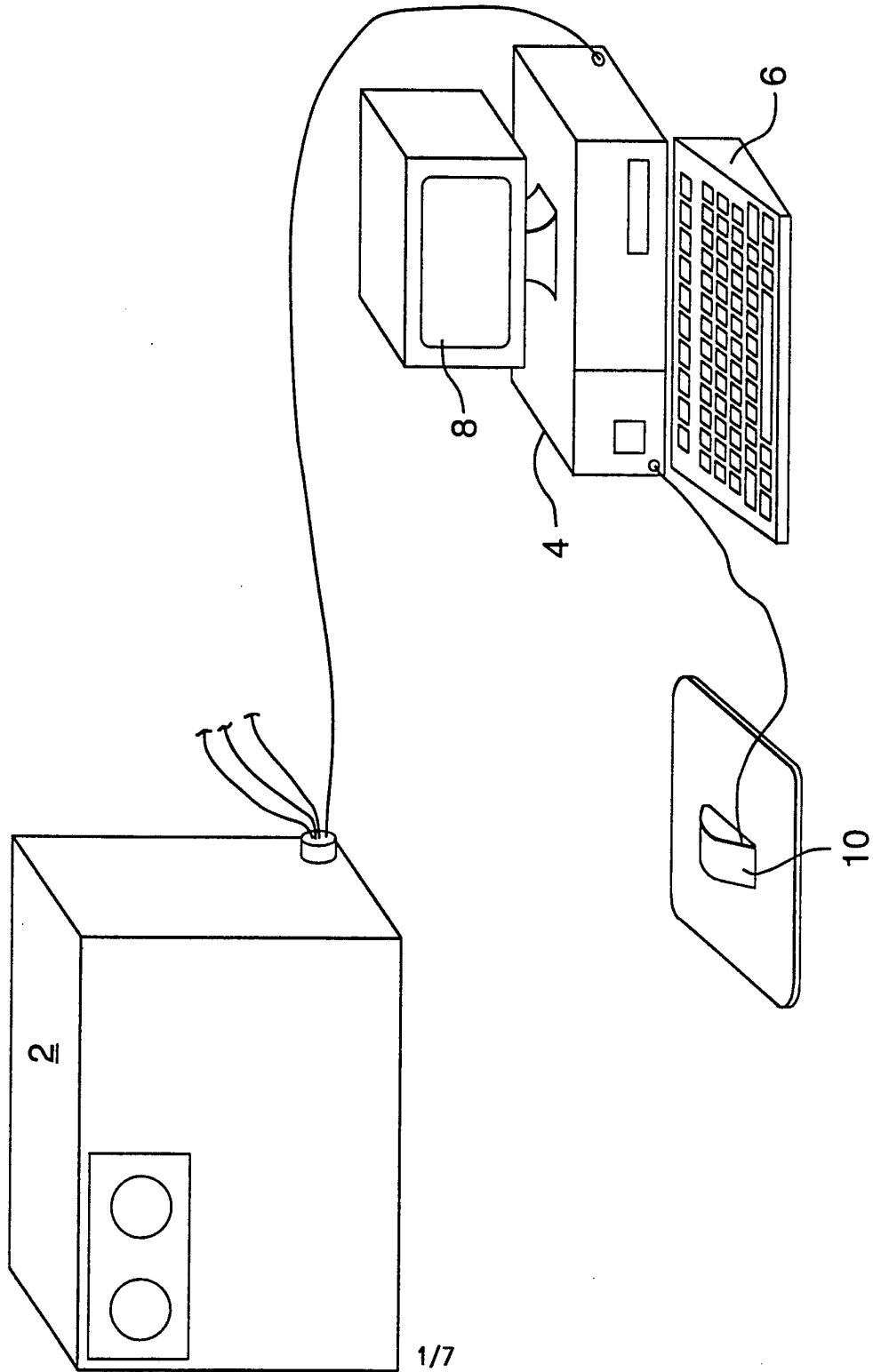

FIG. 1.

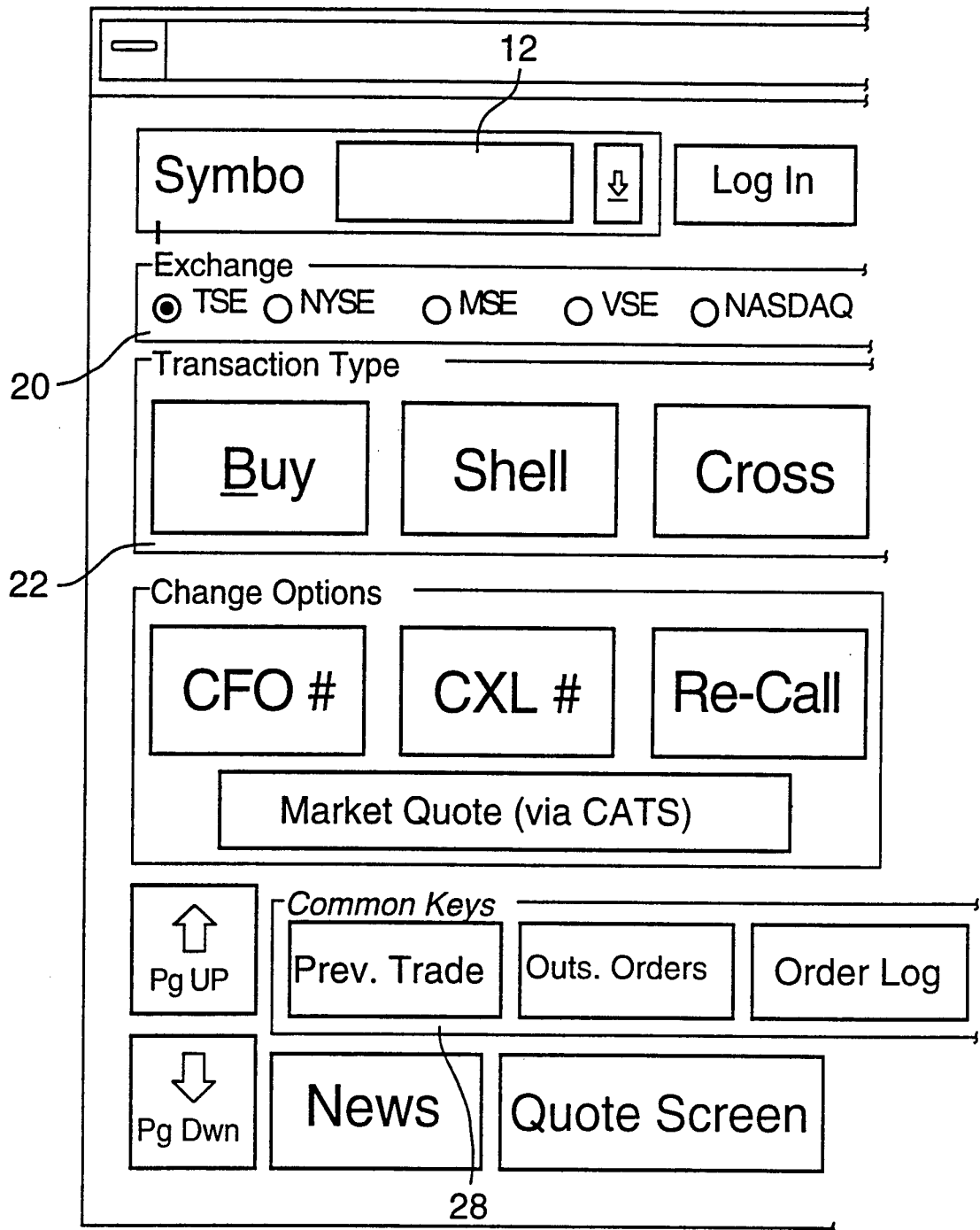

FIG.2 A.

2/7

SUBSTITUTE SHEET

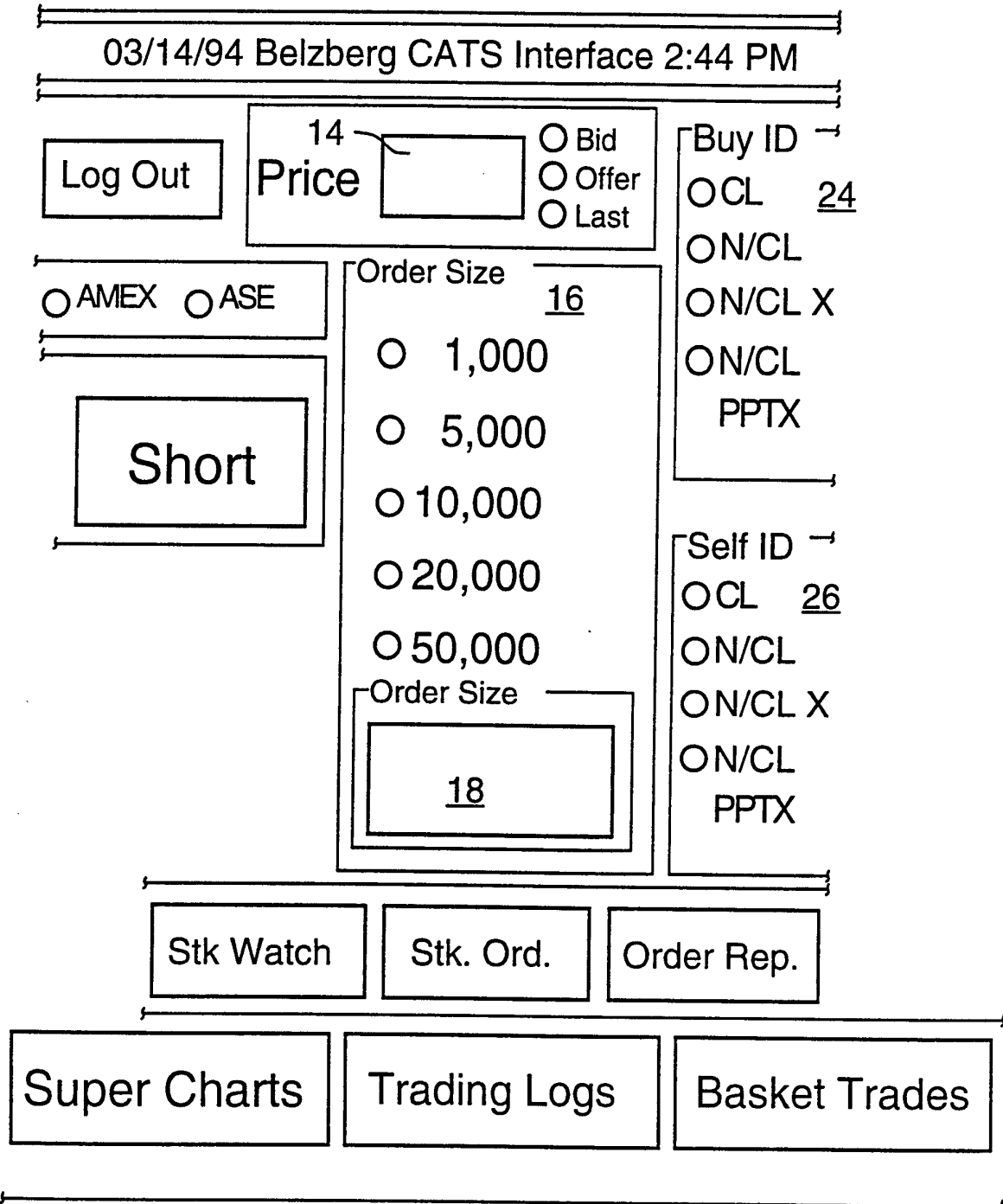

FIG.2B.

3/7

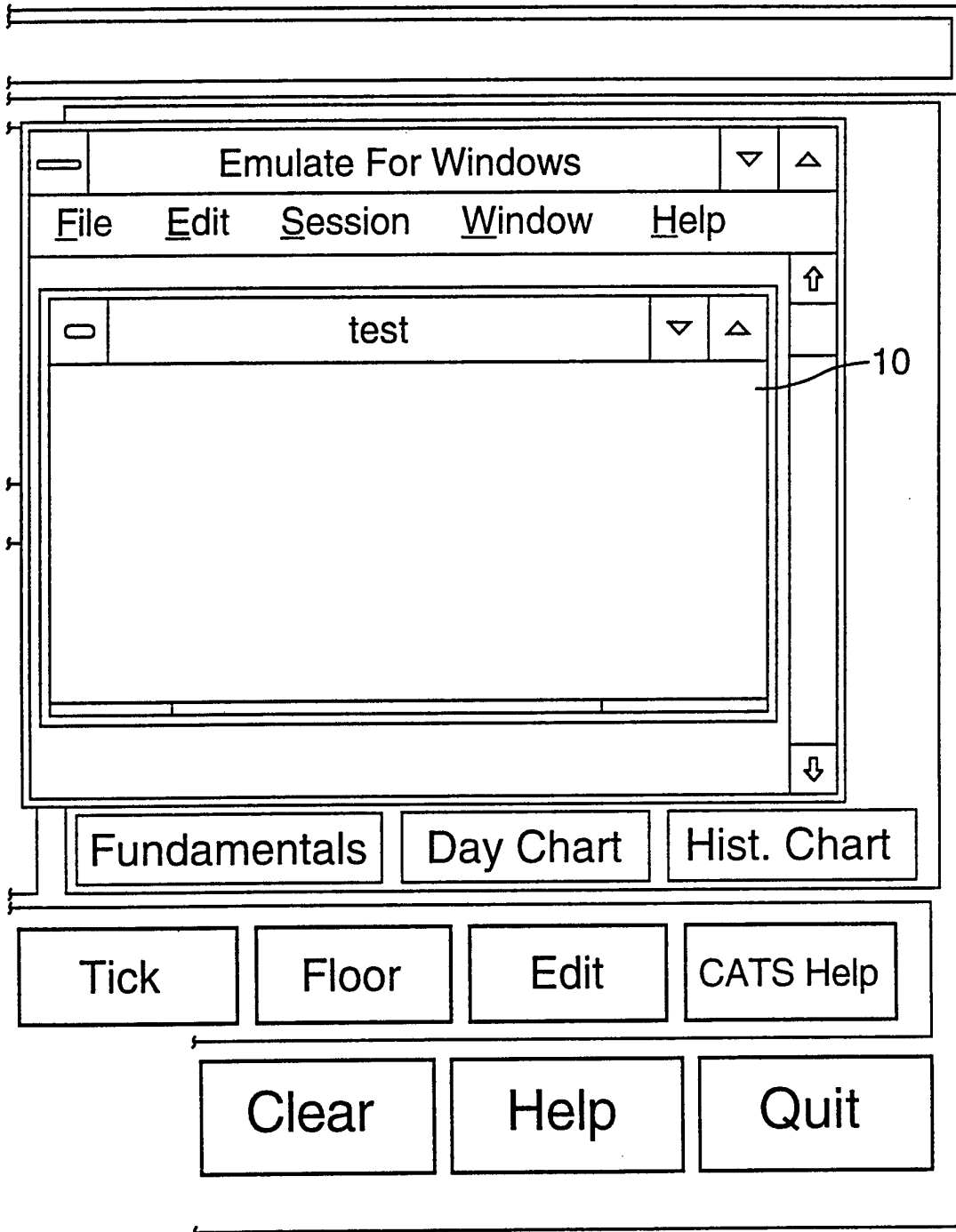

FIG.2C.

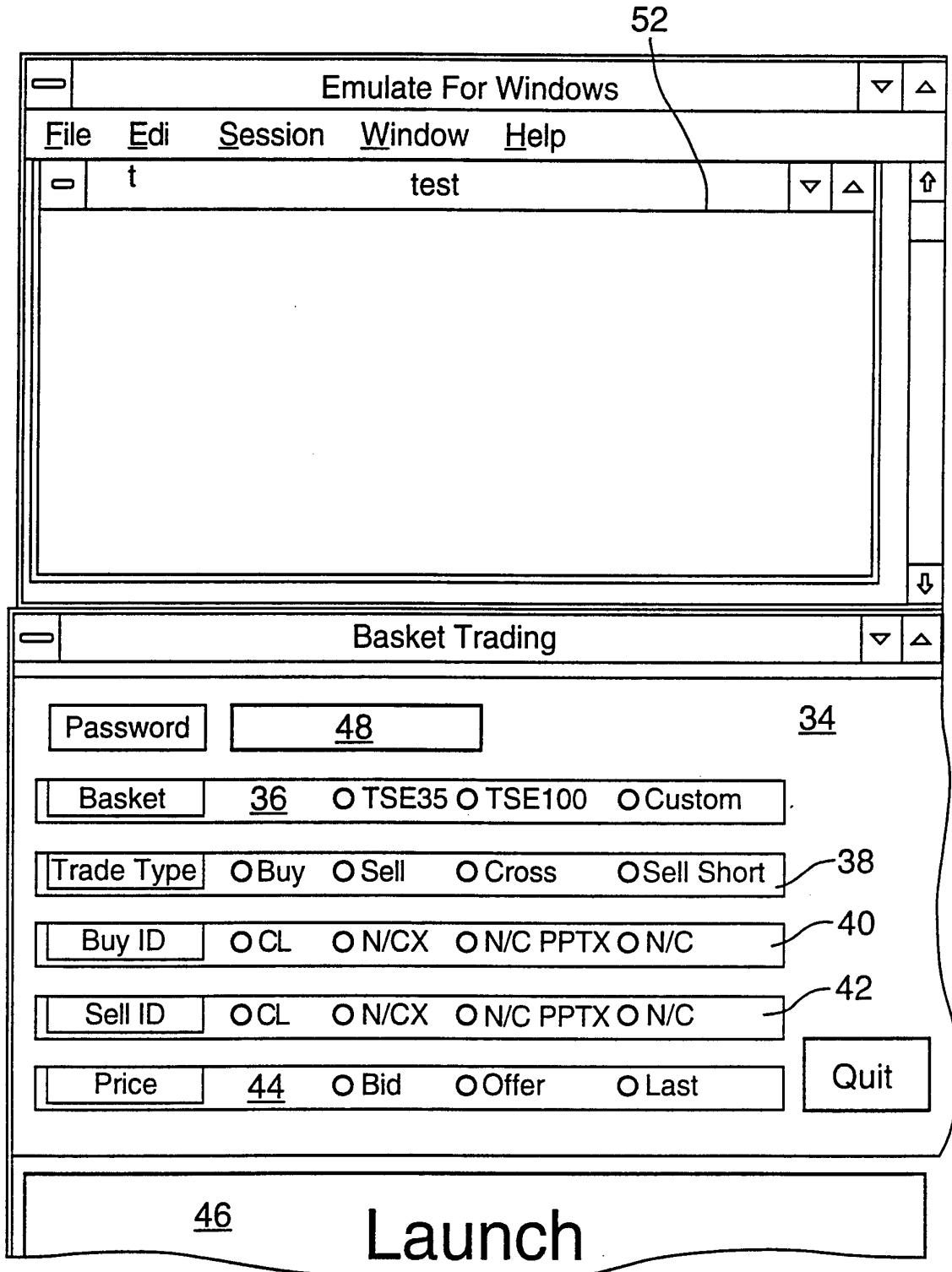

FIG. 3 A.

Microsoft Excel-35EXE.XLS										
File Edit View Insert Format Tools Data Window Help										
MS Sans Serif 10 B I U Σ f A Z % , ° ° 100% ?										
B9	A	B	C	D	E	F	G	H	I	
14										
15			INDEX	220.293597	221.643484		221.01182	223.592281	DOWN	
16	SYM	SHS	Bid Size	Bid	Ask	Ask Size	LAST	Yesterday		
17	AL	1500	115	31	31.125	151	31.125	32		
18	AGT	1000	393	17.125	17.25	475	17.125	17.25		
19	BBDB	1000	128	20	20.125	198	20.125	20.25		
20	B	2000	300	48.625	48.75	646	48.625	48.875		
21	BNS	1000	20	30.75	30.875	464	30.75	31.375		
22	BMO	1400	146	29.125	29.25	282	29.25	29.5		
23	OM	1500	95	34.375	34.625	110	34.375	34.75		
24	CXY	700	17	27.75	27.875	64	27.875	28		
25	OP	2000	41	22.875	23	174	22.875	23.5		
26	CTRA	2000	44	12.375	12.5	171	12.375	12.875		
27	EOO	1000	18	17	17.25	115	17	17.375		
28	IMO	500	17	46.375	46.625	93	46.5	47		
29	IMS	1000	71	39.625	39.75	46	39.625	40.125		
30	LAC	1500	100	11.375	11.5	902	11.375	11.5		
31	LDM.B	1500	888	8.5	8.625	5	8.625	8.875		
32	MB	1000	141	23	23.125	9	23	23.375		
33	MCL	1000	45	25.625	25.75	22	25.625	25.25		
34	MFP	1000	908	16.125	16.25	883	16.125	16.25		

FIG. 3B.

30

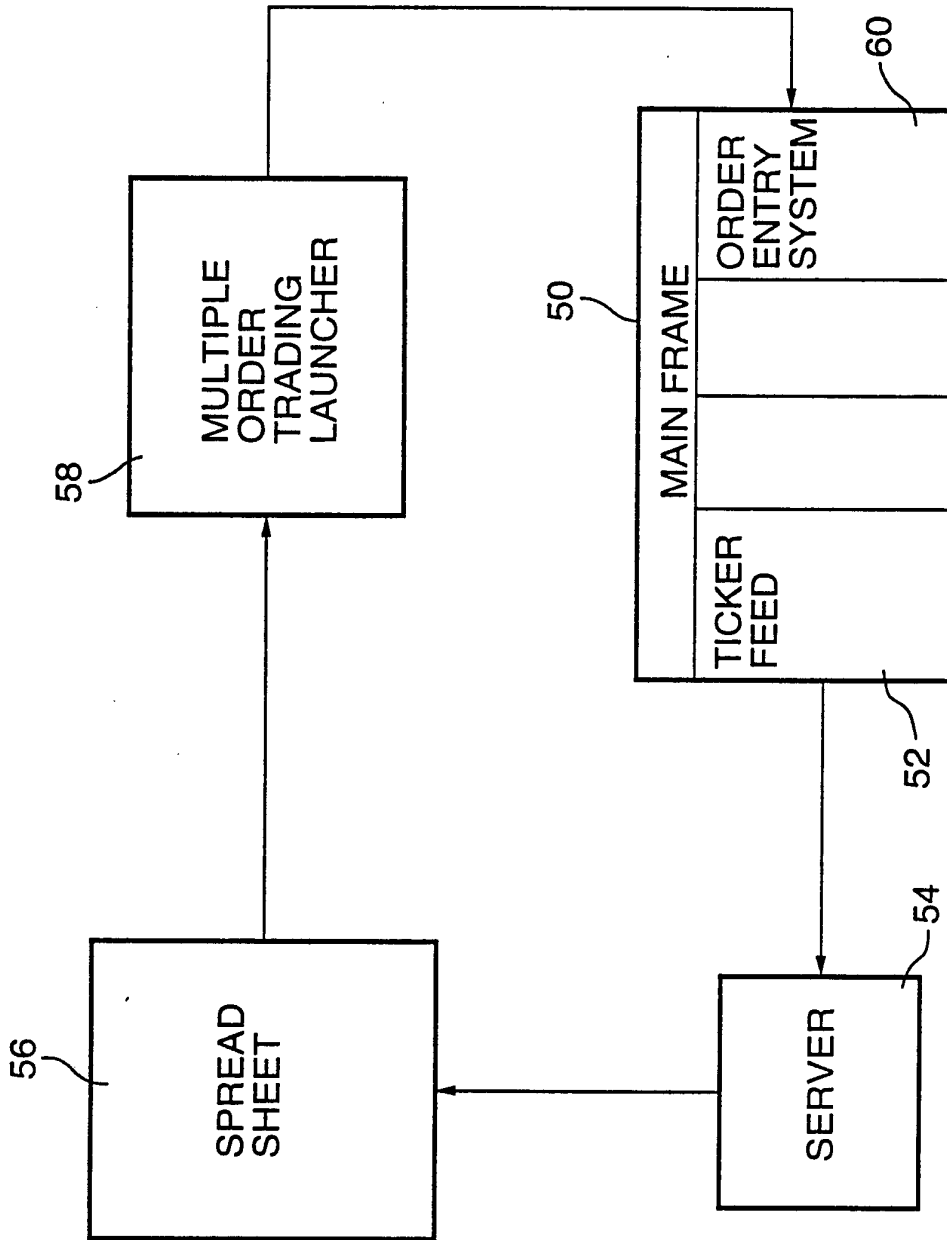

FIG.4.

INTERNATIONAL SEARCH REPORT

International Application No
PCT/CA 95/00123

A. CLASSIFICATION OF SUBJECT MATTER
IPC 6 G06F17/60

According to International Patent Classification (IPC) or to both national classification and IPC

B. FIELDS SEARCHED

Minimum documentation searched (classification system followed by classification symbols)
IPC 6 G06F

Documentation searched other than minimum documentation to the extent that such documents are included in the fields searched

Electronic data base consulted during the international search (name of data base and, where practical, search terms used)

C. DOCUMENTS CONSIDERED TO BE RELEVANT

Category *	Citation of document, with indication, where appropriate, of the relevant passages	Relevant to claim No.
X	EP,A,0 401 203 (MJT HOLDINGS INC) 5 December 1990 see the whole document ---	1-5
X	EP,A,0 453 150 (COMMODITY EXCHANGE INC) 23 October 1991 see the whole document ---	1-5
X	WO,A,91 14231 (CHICAGO TRADE BOARD) 19 September 1991 see the whole document -----	1-5

Further documents are listed in the continuation of box C.

Patent family members are listed in annex.

* Special categories of cited documents :

- "A" document defining the general state of the art which is not considered to be of particular relevance
- "E" earlier document but published on or after the international filing date
- "L" document which may throw doubts on priority claim(s) or which is cited to establish the publication date of another citation or other special reason (as specified)
- "O" document referring to an oral disclosure, use, exhibition or other means
- "P" document published prior to the international filing date but later than the priority date claimed

- "T" later document published after the international filing date or priority date and not in conflict with the application but cited to understand the principle or theory underlying the invention
- "X" document of particular relevance; the claimed invention cannot be considered novel or cannot be considered to involve an inventive step when the document is taken alone
- "Y" document of particular relevance; the claimed invention cannot be considered to involve an inventive step when the document is combined with one or more other such documents, such combination being obvious to a person skilled in the art.
- "&" document member of the same patent family

Date of the actual completion of the international search

21 July 1995

Date of mailing of the international search report

04.08.95

Name and mailing address of the ISA
European Patent Office, P.B. 5818 Patentlaan 2
NL - 2280 HV Rijswijk
Tel. (+ 31-70) 340-2040, Tx. 31 651 epo nl,
Fax: (+ 31-70) 340-3016

Authorized officer

Suendermann, R

INTERNATIONAL SEARCH REPORT

Information on patent family members

International Application No

PCT/CA 95/00123

Patent document cited in search report	Publication date	Patent family member(s)	Publication date
EP-A-0401203	05-12-90	US-A- 5101353	31-03-92
		CA-A- 2016715	30-11-90
		JP-A- 3068067	25-03-91
EP-A-0453150	23-10-91	AU-B- 643982	02-12-93
		AU-A- 7358491	24-10-91
		JP-A- 4227566	17-08-92
WO-A-9114231	19-09-91	US-A- 5297031	22-03-94
		AU-B- 653147	22-09-94
		AU-A- 7493291	10-10-91
		EP-A- 0471063	19-02-92
		JP-T- 4507159	10-12-92