



US 20030120259A1

(19) **United States**

(12) **Patent Application Publication**
Mickley

(10) **Pub. No.: US 2003/0120259 A1**

(43) **Pub. Date: Jun. 26, 2003**

(54) **DEFLECTABLE TIP GUIDE IN GUIDE SYSTEM**

Publication Classification

(75) Inventor: **Timothy J. Mickley**, Elk River, MN (US)

(51) **Int. Cl.⁷** **A61M 25/01**
(52) **U.S. Cl.** **604/528**

Correspondence Address:

CHRISTENSEN, O'CONNOR, JOHNSON, KINDNESS, PLLC
1420 FIFTH AVENUE
SUITE 2800
SEATTLE, WA 98101-2347 (US)

(57) **ABSTRACT**

(73) Assignee: **Scimed Life Systems, Inc.**

Guide catheters which can be used in percutaneous myocardial revascularization (PMR) to deliver therapeutic catheters to difficult to reach heart chamber wall regions. Some guide catheters include distal regions which can be bent under control from the proximal region of the catheter. One steerable guide catheter has a flexible distal region, a more proximal, less flexible intermediate region, a first lumen for receiving a therapeutic catheter, and an elongate manipulation member slidably disposed in a second, blind lumen. The elongate manipulation member can be secured off-center near the distal end of the flexible distal region. The distal region can be bent by retracting the manipulation member and straightened by pushing the manipulation member. Controllably bendable guide catheters according to the present invention can be nested inside other, similar guide catheters. The invention also includes means for resisting free rotation of guide catheters relative to other adjacent catheters or tubes.

(21) Appl. No.: **10/349,535**

(22) Filed: **Jan. 21, 2003**

Related U.S. Application Data

(63) Continuation of application No. 09/695,525, filed on Oct. 24, 2000, now Pat. No. 6,530,914.

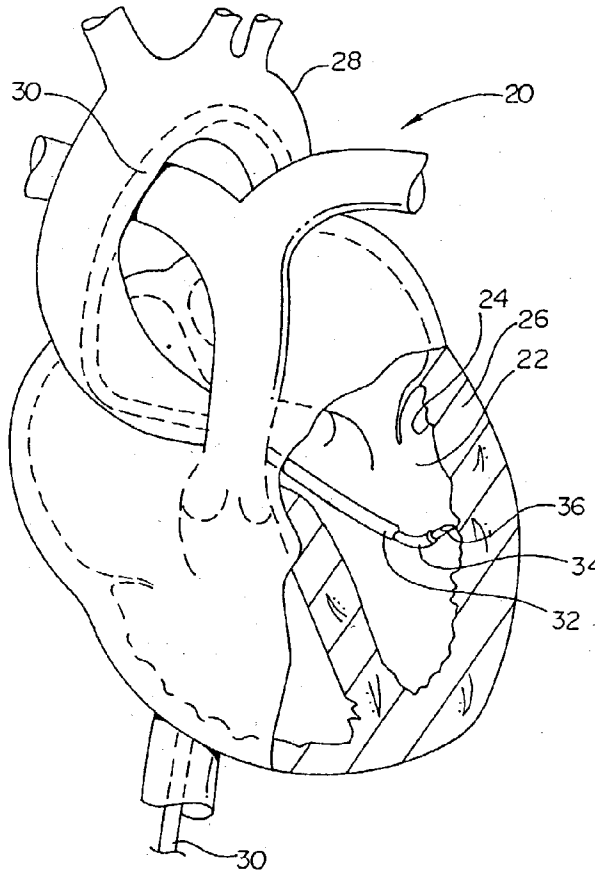

Fig. 4

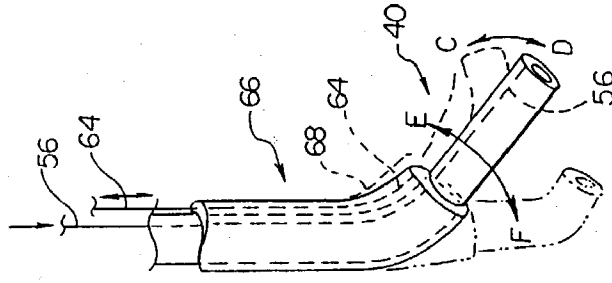

Fig. 3

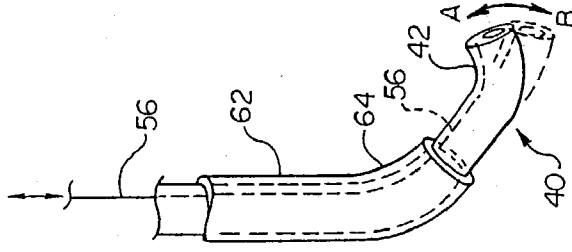

Fig. 6

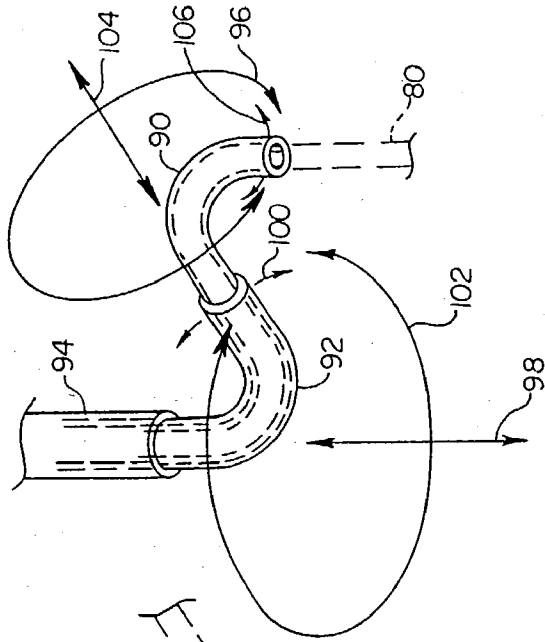

Fig. 5

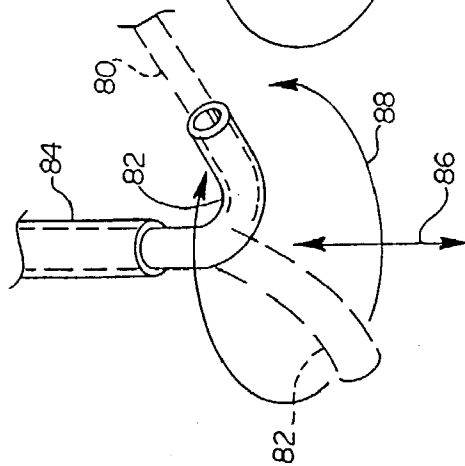

Fig. 7

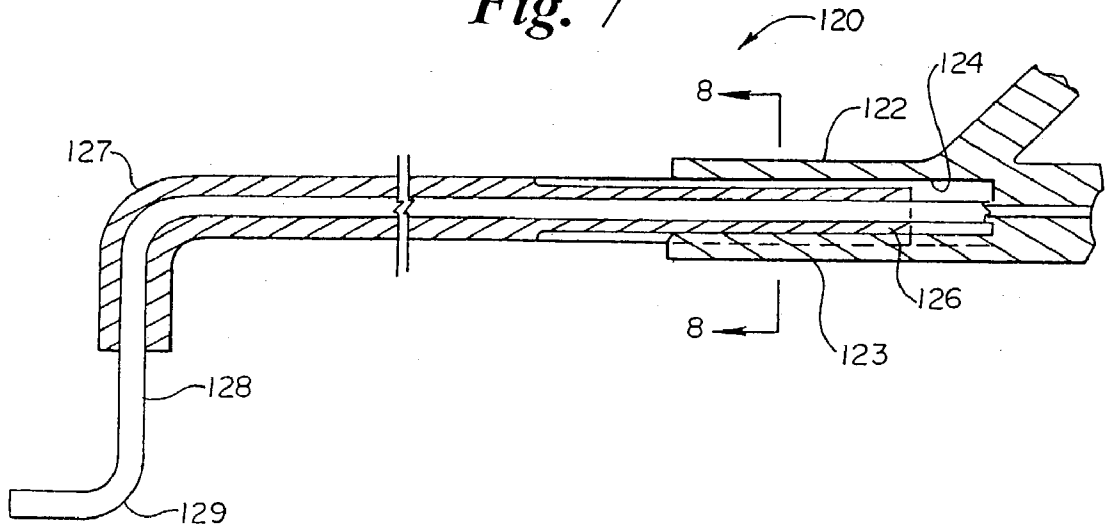

Fig. 9

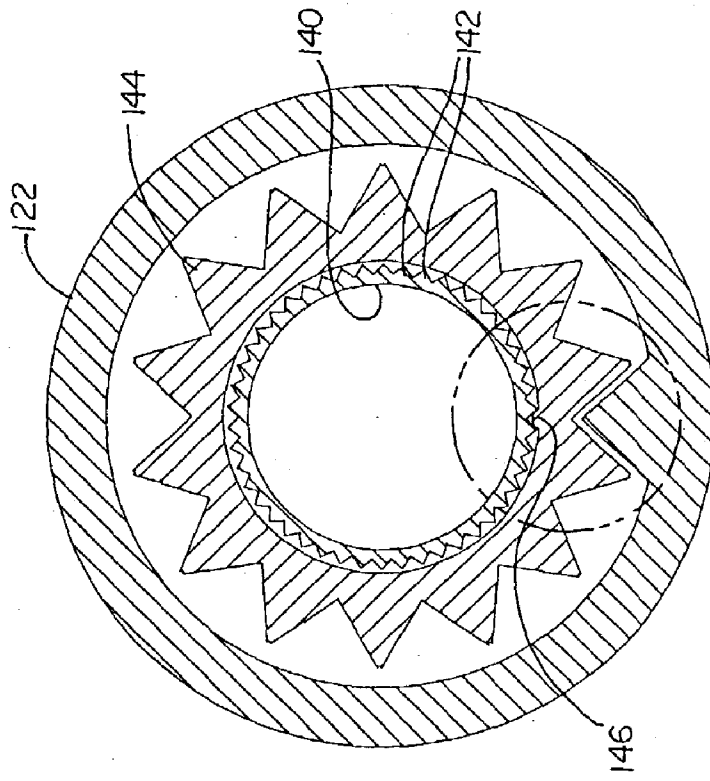

Fig. 8

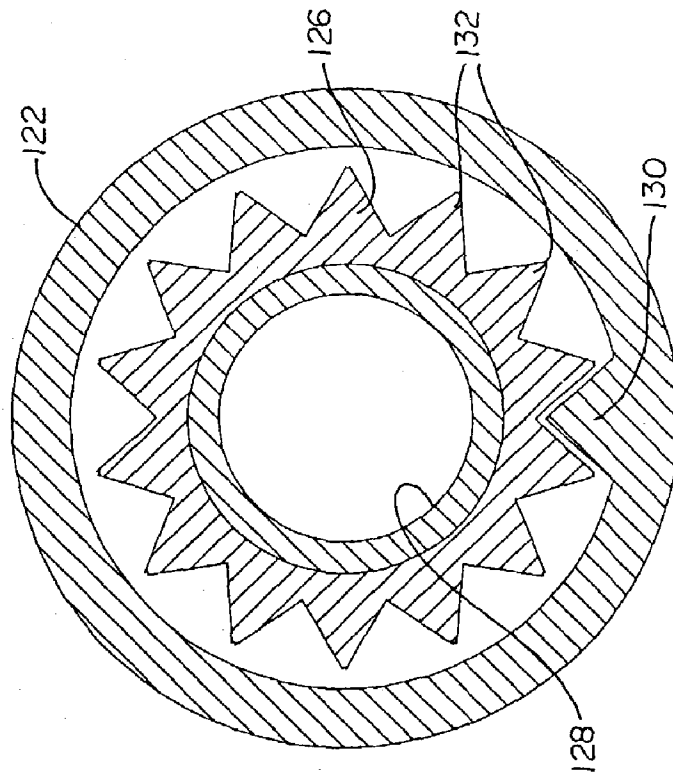
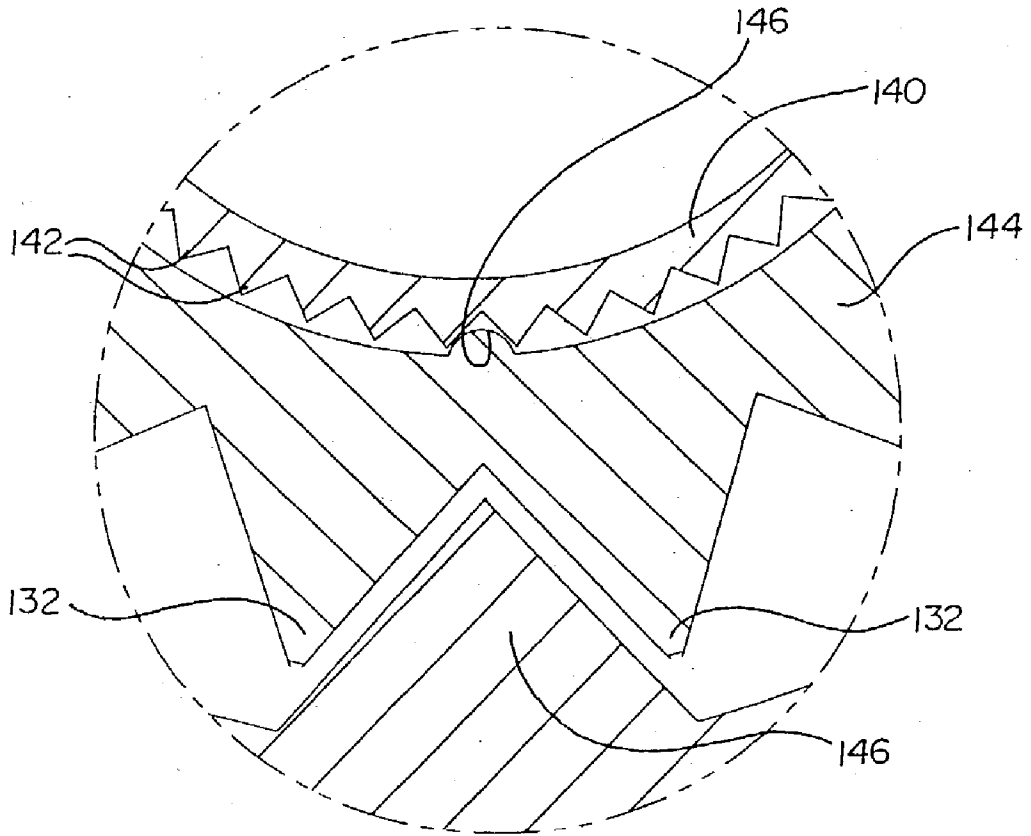

Fig. 10



DEFLECTABLE TIP GUIDE IN GUIDE SYSTEM

FIELD OF THE INVENTION

[0001] The present invention is related generally to medical devices. More specifically, the present invention is related to catheters for performing percutaneous myocardial revascularization (PMR) which is also referred to as transmyocardial revascularization (TMR). The present invention includes guide catheters having proximally controllable distally disposed bendable regions.

BACKGROUND OF THE INVENTION

[0002] A number of techniques are available for treating cardiovascular disease such as cardiovascular by-pass surgery, coronary angioplasty, coronary atherectomy, and stent placement. These techniques are generally applied to bypass or open lesions in coronary vessels to restore patency and increase blood flow to the heart muscle. In some patients, the number of lesions is so great, or the location so remote in the coronary vasculature, that restoring coronary artery blood flow to the heart is difficult. Transmyocardial revascularization (TMR), also known as percutaneous myocardial revascularization (PMR), has been developed as an alternative to these techniques which are directed to bypassing or removing lesions.

[0003] Heart muscle may be classified as healthy, hibernating, and "dead." Dead tissue is not dead but is scarred, no longer contracting, and no longer capable of contracting even if adequately supplied with blood. Hibernating tissue is not contracting muscle tissue but is capable of contracting, provided it is again adequately supplied with blood. PMR is performed by wounding the myocardium of the heart, often forming and leaving patent holes, and sometimes injecting angiogenic substances in the process.

[0004] PMR was inspired in part by observations that reptilian hearts are supplied in large part by blood supplied directly from within the heart chambers. In contrast, mammalian hearts are supplied by blood pumped from the heart, through the aorta, and back into the heart muscle through the coronary arteries. Positive results have been observed in some patients receiving PMR treatments. The positive results may be due in part to blood being perfused into the myocardium from the heart chambers through holes into the myocardium which remain open. The positive results are believed to be due in part to a wound healing response of the myocardium which includes formation of new blood vessels in the heart wall, which are believed to connect with the heart chamber interior and/or other coronary blood vessels. The PMR procedure can include cutting into the myocardium with therapeutic cutting tips, burning holes with therapeutic tips having laser or radio frequency current burning tips. The PMR therapeutic tip can also be used to inject angiogenic substances, such as growth factors or genes selected to cause angiogenesis.

[0005] The PMR procedure generally involves insertion of a therapeutic tip, such as sharp cutting tip, into the heart chamber or chambers selected for treatment. The cutting tip and associated inner shaft can be guided into the chamber through a guide catheter, which may have been inserted into the vasculature a long distance from the heart. After the inner shaft exits the guide catheter, the cutting tip is preferably steered to several positions for forming of several

holes in a pattern across the endocardium. In order to steer the inner shaft and cutting tip, an outer shaft or tube is sometimes disposed coaxially about the inner shaft and within the guide catheter. The outer tube can have structural features at the distal end for bending to various angles to reach various locations in the heart wall. The outer tube and inner shaft can be advanced to bring the cutting tip into contact with the heart wall.

[0006] It may be desirable to revascularize regions of the endocardium that are difficult to reach using conventional guide catheters. For example, it may be important to reach areas of hibernating tissue in superior locations of the left ventricle. Conventional guide catheters may have difficulty bending sufficiently to reach some regions.

[0007] What would be desirable is an improved guide device for steering inner shaft cutting tips into position within the heart myocardium. What would be desirable is a catheter having greater reach and maneuverability in the chambers of the heart.

SUMMARY OF THE INVENTION

[0008] The present invention includes guide catheters which can be used for performing percutaneous myocardial revascularization (PMR). Guide catheters incorporating the present invention can provide distal regions that can be bent through varying angles. The distal region bending is preferably controlled at a proximal region or proximal end of the guide catheter. One controllably bendable guide catheter has a first lumen for receiving and delivering a therapeutic catheter to the guide catheter distal end and beyond. The guide catheter can also have an elongate manipulation member extending from the proximal region of the guide catheter to near the distal end of the guide catheter. The member is preferably secured to a location off-center from the central longitudinal axis of the catheter. In one embodiment, the distal end of the member is bonded to the body of the guide catheter at the distal end of a second, blind lumen near the guide catheter distal end.

[0009] The manipulation member is a pull wire in some embodiments. The manipulation member in one embodiment is a flat metallic ribbon. In some embodiments, the manipulation member is a pull wire which may be formed from metal. In one embodiment, the member is capable of both pushing on the distal region to straighten the distal region and pulling on the distal region through the off-center attachment point to impart a curve or bend to the distal region. In another embodiment, the manipulation member is sufficiently strong only in tension, with a straightening bias in the distal region used to straighten the distal region when tension is released. The guide catheter distal region is preferably formed of a more flexible material than the more proximal intermediate guide catheter region.

[0010] A controllably bendable guide catheter, according to the present invention, can be inserted through a conventional guide catheter in one PMR system. In another PMR system, the bendable guide catheter is nested within a second controllably bendable guide catheter. This can provide for great flexibility in reaching otherwise hard to reach sites in the endocardium.

[0011] Another aspect of the present invention provides for inhibiting free rotation between nested, rotating tubes

such as the nested guide catheter tubes. The rotation inhibitor can include internal and external teeth on opposing external and internal opposing surfaces, respectively. The teeth can engage each other and resist rotation between the inner and outer tubes. When the applied rotational force exceeds a threshold, elastic deformation of the teeth can allow slippage between the opposed teeth and the two tubes. Providing resistance to free rotation between the tubes can lessen the rotation of the two tubes relative to one another in the case where torque has been applied to one tube, but has not been translated to rotational motion at the distal end. The applied torque may have been stored in the intermediate portion of the tube and can cause unwanted rotation of either tube at the proximal end. A ratcheting mechanism can be provided which urges the tubes to stay in position after the treating physician's hands are removed from the device

BRIEF DESCRIPTION OF THE DRAWINGS

[0012] FIG. 1 is a perspective, cutaway view of a heart having a PMR therapeutic catheter disposed within a steerable or controllably bendable guide catheter disposed within a guide catheter;

[0013] FIG. 2 is a fragmentary, perspective, cutaway view of a controllably bendable guide tube having a bendable distal region and an elongate manipulation member;

[0014] FIG. 3 is a fragmentary, perspective view of a steerable inner guide catheter disposed within an outer guide catheter;

[0015] FIG. 4 is a fragmentary, perspective view of a steerable inner guide catheter disposed within an outer steerable guide catheter;

[0016] FIG. 5 is a fragmentary, perspective view of a PMR therapeutic catheter disposed within a steerable guide catheter disposed within a guide catheter;

[0017] FIG. 6 is a fragmentary, perspective view of a PMR therapeutic catheter disposed within a steerable inner guide catheter disposed within an outer steerable guide catheter disposed within a guide catheter;

[0018] FIG. 7 is a longitudinal cross-sectional view of a rotatable, steerable guide catheter disposed within a rotatable guide catheter disposed within a proximal hub;

[0019] FIG. 8 is a transverse cross-sectional view of the catheter of FIG. 7 taken through place 8-8, illustrating external teeth on the rotatable, steerable guide catheter engaged with an internal tooth on the rotatable guide catheter for inhibiting free rotation between the two;

[0020] FIG. 9 is a transverse cross-sectional view somewhat similar to that of FIG. 8, wherein the steerable guide catheter has external teeth engaged with an internal tooth of the rotatable guide catheter; and

[0021] FIG. 10 is a detailed view of the inset portion of FIG. 9.

DETAILED DESCRIPTION OF THE INVENTION

[0022] FIG. 1 illustrates a human heart 20 having a left ventricle 22, an inner layer to a heart chamber wall or endocardium 24, a heart chamber wall or myocardium 26, and an aortic arch 28. Disposed through the aortic arch is a

percutaneous myocardial revascularization (PMR) device 30, extending into left ventricle 22 and having an outer guide tube 32, an inner guide tube 34, and a therapeutic catheter therapeutic tip 36 near endocardium 24. As can be seen from inspection of FIG. 1, left ventricle 22 includes upper or superior regions that may require a bend in PMR device 30 in order to reach the superior regions of the myocardium. In the embodiment illustrated, inner guide catheter 34 includes a bent distal region for orienting therapeutic catheter tip 36 toward a target location in the myocardium.

[0023] Referring now to FIG. 2, one embodiment of a steerable or bendable guide catheter 40 is illustrated in more detail. Guide catheter 40 includes a distal region 42, an intermediate region 44 disposed proximal of the distal region, and a distal end 46. A longitudinal center axis 48 is illustrated near distal end 46, as is an off-center axis 50 disposed laterally offset from center axis 48. Guide catheter 40 includes a lumen 52 for receiving a therapeutic catheter, or, in some embodiments, another guide catheter. A second lumen 54 is illustrated, having an elongate manipulation member 56 disposed within. Second lumen 54 need not extend through to distal end 46 in most embodiments. In the embodiment illustrated, elongate manipulation member 56 is secured to the body of catheter 40 at an off-center attachment point 58 which is located along off-center axis 50. By pulling on manipulation member 56 which is attached off-center to guide catheter 40, distal region 42 can be made to bend or deflect. In one embodiment, manipulation member 56 is sufficiently strong in tension to pull distal region 42 to bend the region, and sufficiently strong in compression to push distal region 42 to straighten the region. In one embodiment, manipulation member 56 is a flat wire. In one embodiment, manipulation member 56 is a pull wire strong enough in tension to bend distal region 42 but insufficiently strong in compression to straighten distal region 42, with distal region 42 being biased to a straight position and resuming that position when the tension of manipulation member 56 is released.

[0024] Guide catheter 40 distal region 42 is preferably formed of a more flexible material than intermediate region 44. In the embodiment illustrated, distal region 42 is bonded to intermediate region 44 along a plane as illustrated at 60. In one embodiment, distal region 42 and intermediate region 44 are formed of materials such as polyether ester elastomer (for example, ARNITEL®, available from DSM Engineering Plastics), a polyester elastomer (for example, HYTREL®, available from DuPont Corporation), a polyether block amide (for example, PEBAX®), or Nylon. The two regions can be bonded together using a method well known to those skilled in the art, such as adhesive application or heat bonding. In one embodiment, intermediate region 44 is formed from the same polymer as distal region 42, but having a higher durometer value.

[0025] Referring now to FIG. 3, steerable guide catheter 40 having bendable distal region 42 is shown disposed within a second guide catheter 62 having a bent distal region 64. In some embodiments, distal bent region 64 is relatively fixed in the degree of bend, and the bend may be used in part to gain entry to the left ventricle. The length of guide catheter 40 that extends from second guide catheter 62 can be varied to reach varying locations of the endocardium in the heart chambers such as the left ventricle. The distal bend of guide catheter 40 can be used to point a therapeutic

catheter to various locations in the heart wall. Guide catheter distal region 42 is illustrated in a first bend position "A" and a second, straighter bend position "B". In the embodiment illustrated, movement between positions A and B is accomplished through the longitudinal movement of elongate manipulation member 56.

[0026] Referring now to FIG. 4, guide catheter 40 is shown disposed within a steerable second guide catheter 66 having a distal bend region 68. Guide catheter 40 is shown in two positions, "C" and "D", while second steerable guide catheter 62 is illustrated in two positions, "E" and "F." Second steerable guide catheter 66 controls the bend of distal region 68 through a slidable elongate manipulation member 64. As shown in FIG. 4, the combination of two independently controlled degrees of bending allows a large degree of control over where in the heart chamber a carried therapeutic catheter tip is to be delivered.

[0027] FIG. 5 illustrates a therapeutic cutting tip catheter 80 disposed within a bent, steerable guide catheter 82 slidably and rotatably disposed within an outer guide catheter 84. FIG. 5 illustrates the range of motion possible through rotation and axial movement, with rotation indicated at 88 and axial movement indicated at 86. These ranges of movement are also possible in addition to the illustrated controlled bending illustrated in FIGS. 3 and 4, but difficult to show on the same figure.

[0028] FIG. 6 illustrates yet another embodiment, illustrating therapeutic cutting tip catheter 80 slidably disposed within a first bendable guide catheter 90 which is slidably and rotatably disposed within a second bendable guide catheter 92, which is in turn slidably and rotatably disposed within a third, more conventional guide catheter 94. The range of motion of guide catheter 90 is indicated by rotation at 96, axial movement at 104, and bending at 106. Similarly, the range of motion of guide catheter 92 is indicated by rotation at 102, axial movement at 98, and bending at 100.

[0029] In one embodiment, guide catheters 90 and 92 are controlled with an elongate manipulation member similar to guide catheters 40 and 66 of FIG. 4. FIG. 6 thus illustrates how bendable, steerable guide catheters can be nested within each other to multiple levels to achieve a large range of motion. With reference to FIGS. 1, 5 and 6, it may be seen that the bendable distal region of the guide catheters can bring a large portion of the left ventricle endocardium into range of the catheter therapeutic tip, giving the ability to treat a large portion of the left ventricle myocardium.

[0030] Referring now to FIG. 7, another aspect of the present invention is illustrated. Inspection of FIGS. 4 through 6 illustrates guide tubes disposed within guide tubes. As explicitly indicated in FIG. 5 at 88 and in FIG. 6 at 96 and 102, rotation of tubes within tubes is possible. In order to provide the largest tubular lumens while providing small outer diameters, the nested guide catheters may be closely matched in size, with little wasted space in between the outside wall of an inner tube and the inside wall of an outer tube. In some embodiments, the catheters allow for more space in between the tubes, but can have one wall lying more closely to one wall than another, as the nested guide catheters are curved around tortuous vessels turns which can force the inner catheter off-center to lie more closely to one inside surface of the outer catheter.

[0031] The closeness of one or both walls of the inner and outer catheters can thus inhibit rotation of one tube relative

to another tube. In particular, applied rotational force may not be completely translated into rotational movement at the far distal end of the inner catheter. This can result in some applied torque being stored as torsional energy in the inner catheter. When the treating physician releases the inner catheter proximal end after applied torque to the inner catheter, the proximal end of the inner catheter may spring back. If the outer catheter was being held and then released, the outer tube may spring in the same direction as the applied force to the inner tube. Thus, it is possible for one tube to freely rotate even in the absence of currently applied force to that tube by the treating physician.

[0032] FIGS. 7 and 8 illustrate a catheter system 120 having structures for inhibiting the undesirable rotational movement of one catheter when no torque is being applied at the proximal end by the treating physician. The structures can prevent the guide catheters from undesirably rotating one within the other. Catheter system 120 includes a proximal region 123, and a proximal hub 122 having a lumen 124 therein for receiving a first guide catheter 126, which is disposed about a second guide catheter 128. In the embodiment illustrated, first guide catheter 126 has a distal region 127 having a bend and second catheter 128 also has a distal region 129 having a bend. In one embodiment, second catheter distal region 129 can be bent, with the bending being controlled from a more proximal region of the catheter. Second catheter 128 can be rotated relative to first catheter 126, and first catheter 126 can be rotated relative to enclosing hub 122.

[0033] FIG. 8 illustrates an aspect of the invention which can inhibit free rotation of first catheter 126 relative to hub 122. Hub 122 has an internal tooth 130 and first catheter 126 has several outwardly extending teeth 132 in proximal hub region 123. When first catheter 126 is rotated relative to hub 122 and/or second catheter 128 is rotated relative to first catheter 126, rotational energy may later cause first catheter 126 to rotate. To inhibit this free rotation, tooth 130 engages teeth 132 and inhibits this free rotation. When sufficient force is applied, the teeth can be forced to move over each other, allowing for rotation. In one embodiment, this movement is possible due to the elastic deformation of at least one of the pairs of opposing teeth. In one embodiment, the outer tooth is replaced by multiple teeth. The inner and outer teeth may be formed of materials such as DELRIN® (an acetal plastic available from DuPont Chemical Company), PEBAX® (polyether block amide), polyesters, polycarbonate, ABS (acrylonitrile butadiene styrene), acrylic, or ULTEM® (a polyetherimide available from General Electric Corporation).

[0034] FIG. 9 illustrates another embodiment having teeth on both an inner and an outer guide catheter. An inner guide catheter 140 is disposed within an outer guide catheter 144, which is in turn disposed within hub 122. In the embodiment illustrated, inner guide catheter 140 has several outer teeth 142 which engage a single inwardly oriented tooth 146 of outer guide catheter 144. In this embodiment, the free rotation of inner catheter 140 relative to outer guide catheter 144 is inhibited. FIG. 10 illustrates outer guide catheter 144 with inwardly disposed tooth 146 in greater detail. FIGS. 8, 9, and 10 illustrate embodiments of the invention capable of resisting stored torsional energy from causing free rotation of the guide catheter when the applied torque is removed.

[0035] In use, a guide catheter according to the present invention can be advanced to a target site. In some methods, this is accomplished by first introducing a guide wire through the vasculature and into a heart chamber to be treated, such as the left ventricle. For example, a guide wire can be introduced into the femoral artery near the groin, and advanced over the aortic arch and into a chamber of the heart. A guide catheter can then be advanced over the guide wire. The first guide catheter can be followed by a second guide catheter, either over the first guide catheter or over the guide wire within the first guide catheter. The guide wire can be retracted and a therapeutic catheter advanced through the inner most guide catheter. Multiple guide catheters can thus be advanced to position.

[0036] In some applications of the present invention, a steerable guide catheter having a controllably bendable distal region is disposed within a conventional guide catheter. The conventional guide catheter can terminate distally in either a straight distal region or a curved distal region, depending on the application. In other applications, a first guide catheter having a controllably bendable distal region is disposed within a second guide catheter having a controllably bendable guide catheter. In either case, the guide catheter or catheters can be advanced into the heart chamber with the therapeutic catheter tip disposed within the inner most guide catheter.

[0037] The innermost guide catheter can be extended toward a target site of interest with the longitudinal extension and radial rotation of the catheter proximally controlled by the treating physician. The bending of the guide catheter distal region can also be controlled by the treating physician. In preferred embodiments, at least a portion of the therapeutic catheter or therapeutic tip is radiopaque to make the tip location visible under fluoroscopy. The extension, rotation, and bending can be observed under fluoroscopy, with the extension, rotation, and manipulation of bending controlled in response to the image seen under fluoroscopy. In some methods, one or two of the movements, extension, rotation, or bending, may be controlled while the other one or two movements are varied in order to cover a pattern of the heart wall. For example, the rotation may be held constant, and the bend may be varied, with the longitudinal extension being varied sufficiently to reach the heart wall. For example, the bend may be held constant, and the rotation may be varied, to cover a circular pattern over a portion of the heart wall. In use, various therapeutic tips may be delivered to the endocardium, including cutting tips, burning tips, and angiogenic substance injecting tips.

[0038] Numerous advantages of the invention covered by this document have been set forth in the foregoing description. It will be understood, however, that this disclosure is, in many respects, only illustrative. Changes may be made in details, particularly in matters of shape, size, and arrangement of parts without exceeding the scope of the invention. The invention's scope is, of course, defined in the language in which the appended claims are expressed.

What is claimed is:

1. A system for performing myocardial revascularization comprising:

a first elongate tube having a distal region, a distal end, a proximal region, a first lumen therethrough, means for

bending said distal region, and means for controlling said distal region bending from said proximal region; and

a therapeutic catheter having a distal end slidably disposed within said first tube lumen.

2. A system for performing myocardial revascularization as recited in claim 1, wherein said therapeutic catheter distal end has a distal tip having a first position extending distally from said first tube distal end, a second position retracted proximally within said first tube distal end, and means for urging said therapeutic catheter distal end between said first and second positions.

3. A system for performing myocardial revascularization as recited in claim 1, wherein said therapeutic catheter distal end includes means for penetrating said myocardium.

4. A system for performing myocardial revascularization as recited in claim 1, wherein said first tube has an intermediate region proximal of said distal region and said distal region is more flexible than said intermediate region.

5. A system for performing myocardial revascularization as recited in claim 1, wherein said first tube distal region has a longitudinal center axis and an off-center location disposed off said center axis, and said means for bending includes means for pulling and pushing on said off-center location.

6. A system for performing myocardial revascularization as recited in claim 5, wherein said means for pushing and pulling includes an elongate manipulation member operably coupled to said off-center location and extending proximally at least to said proximal region.

7. A system for performing myocardial revascularization as recited in claim 6, wherein said first tube has a second lumen therein and said elongate manipulation member is disposed in said second lumen.

8. A system for performing myocardial revascularization as recited in claim 1, further comprising a second tube having a distal region, a proximal region, a distal end, and a second lumen therethrough, said second tube having said therapeutic catheter disposed within said second lumen, said second tube being disposed within said first tube first lumen.

9. A system for performing myocardial revascularization as recited in claim 8, wherein said second tube has means for bending said second tube distal region and means for extending said second tube distal region distally from said first tube distal end.

10. A system for performing myocardial revascularization as recited in claim 9, wherein said second tube further comprises means for controlling said second tube distal region bending from said second tube proximal region.

11. A system for performing myocardial revascularization as recited in claim 10, wherein said second tube means for controlling bending includes a second elongate manipulation member disposed within said second tube.

12. A guiding catheter system for performing myocardial revascularization comprising:

a first guide tube having a proximal region and a first lumen therethrough, said first lumen having an inside surface;

a second guide tube having a proximal region and a second lumen therethrough, said second guide tube being disposed at least partially in said first tube first

lumen and having an outer surface opposing said first tube inside surface; and

means for resisting free rotation between said first and second tubes.

13. A guiding catheter system for performing myocardial revascularization as recited in claim 12, wherein said means for resisting free rotation is disposed on said opposing surfaces.

14. A guiding catheter system for performing myocardial revascularization as recited in claim 13, wherein said means for resisting free rotation includes a plurality of teeth disposed on at least one of said opposing surfaces and at least one tooth on the other said opposing surfaces for engaging said plurality of teeth.

15. A guiding catheter system for performing myocardial revascularization as recited in claim 14, wherein said plurality of teeth is disposed on said first tube outer surface and said at least one tooth is disposed on said second tube inner surface.

16. A guide catheter for performing myocardial revascularization comprising:

an elongate tube having a distal region, a distal end, a proximal region, a first lumen therethrough, and a longitudinal center axis;

a second lumen extending from said proximal region to at least said distal region; and

an elongate manipulation member disposed in said second lumen, being accessible from said proximal region, and being operably secured to said tube distal region at a location off-center from said tube longitudinal center axis, such that said-tube distal region can be bent by proximally pulling on said manipulation member.

17. A guide catheter for performing myocardial revascularization as recited in claim 16, wherein said tube has an intermediate region proximally near said distal region, and said distal region is more flexible than said intermediate region.

* * * * *