



(43) International Publication Date
29 August 2013 (29.08.2013)

- (51) International Patent Classification:
H04L 27/26 (2006.01) *H04L 1/00* (2006.01)
- (21) International Application Number:
PCT/KR2013/001323
- (22) International Filing Date:
20 February 2013 (20.02.2013)
- (25) Filing Language: English
- (26) Publication Language: English
- (30) Priority Data:

61/600,999	20 February 2012 (20.02.2012)	US
61/602,587	23 February 2012 (23.02.2012)	US
61/619,408	2 April 2012 (02.04.2012)	US
61/646,353	13 May 2012 (13.05.2012)	US
- (71) Applicant: **LG ELECTRONICS INC.** [KR/KR]; 20 Yeouido-dong, Yeongdeungpo-gu, Seoul 150-721 (KR).
- (72) Inventors: **PARK, Jonghyun**; LG Institute, #533 Hogye 1(il)-dong, Dongan-gu, Anyang-si, Gyeonggi-do 431-080 (KR). **SEO, Hanbyul**; LG Institute, #533 Hogye 1(il)-dong, Dongan-gu, Anyang-si, Gyeonggi-do 431-080 (KR).

KIM, Kijun; LG Institute, #533 Hogye 1(il)-dong, Dongan-gu, Anyang-si, Gyeonggi-do 431-080 (KR). **KIM, Byoungsoon**; LG Institute, #533 Hogye 1(il)-dong, Dongan-gu, Anyang-si, Gyeonggi-do 431-080 (KR).

(74) Agents: **KIM, Yong In** et al.; KBK & Associates, 7th Floor, Hyundai Building, 175-9 Jamsil-dong, Songpa-ku, Seoul 138-861 (KR).

(81) Designated States (unless otherwise indicated, for every kind of national protection available): AE, AG, AL, AM, AO, AT, AU, AZ, BA, BB, BG, BH, BN, BR, BW, BY, BZ, CA, CH, CL, CN, CO, CR, CU, CZ, DE, DK, DM, DO, DZ, EC, EE, EG, ES, FI, GB, GD, GE, GH, GM, GT, HN, HR, HU, ID, IL, IN, IS, JP, KE, KG, KM, KN, KP, KR, KZ, LA, LC, LK, LR, LS, LT, LU, LY, MA, MD, ME, MG, MK, MN, MW, MX, MY, MZ, NA, NG, NI, NO, NZ, OM, PA, PE, PG, PH, PL, PT, QA, RO, RS, RU, RW, SC, SD, SE, SG, SK, SL, SM, ST, SV, SY, TH, TJ, TM, TN, TR, TT, TZ, UA, UG, US, UZ, VC, VN, ZA, ZM, ZW.

(84) Designated States (unless otherwise indicated, for every kind of regional protection available): ARIPO (BW, GH,

[Continued on next page]

(54) Title: METHOD AND APPARATUS FOR TRANSMITTING UPLINK SIGNAL IN WIRELESS COMMUNICATION SYSTEM

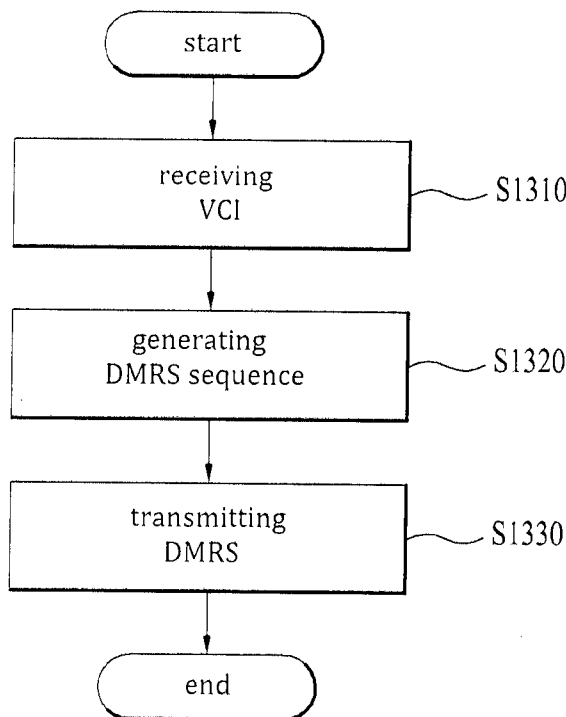

(57) Abstract: The present invention relates to a wireless communication system, and more particularly, to a method and apparatus for transmitting an uplink signal. A method for transmitting an uplink signal at a UE in a wireless communication system includes, when a virtual cell ID for a reference signal for demodulation of a physical uplink channel is provided, generating a sequence of the reference signal on the basis of the virtual cell ID, and transmitting the generated reference signal to an eNB. A cyclic shift hopping pattern of the reference signal can be determined on the basis of the virtual cell ID.

WO 2013/125840 A1

GM, KE, LR, LS, MW, MZ, NA, RW, SD, SL, SZ, TZ, UG, ZM, ZW), Eurasian (AM, AZ, BY, KG, KZ, RU, TJ, TM), European (AL, AT, BE, BG, CH, CY, CZ, DE, DK, EE, ES, FI, FR, GB, GR, HR, HU, IE, IS, IT, LT, LU, LV, MC, MK, MT, NL, NO, PL, PT, RO, RS, SE, SI, SK, SM, TR), OAPI (BF, BJ, CF, CG, CI, CM, GA, GN, GQ, GW, ML, MR, NE, SN, TD, TG).

Published:

- *with international search report (Art. 21(3))*
- *before the expiration of the time limit for amending the claims and to be republished in the event of receipt of amendments (Rule 48.2(h))*

【DESCRIPTION】**【Invention Title】****METHOD AND APPARATUS FOR TRANSMITTING UPLINK SIGNAL IN WIRELESS COMMUNICATION SYSTEM**5 **【Technical Field】**

[1] The present description relates to wireless communication, and more specifically, to a method and apparatus for transmitting an uplink signal.

【Background Art】

10 **[2]** To satisfy increasing data throughput in a wireless communication system, MIMO, multi-base station cooperation technology, etc. for increasing throughput of data transmitted in a limited frequency band have been developed.

[3] An enhanced wireless communication system that supports multi-base station cooperative communication through which a plurality of eNBs communicate with user equipments (UEs) using the same time-frequency resource can provide increased data throughput, compared to a conventional wireless communication system in which one eNB communicates with UEs. eNBs participating in cooperative communication may be referred to as cells, antenna ports, antenna port groups, RRHs (Remote Radio Heads), transport points, reception points, access points, etc.

【Disclosure】20 **【Technical Problem】**

[4] With the introduction of new wireless communication technology, the number of UEs to which an eNB needs to provide a service in a predetermined resource region increases and the quantity of data and control information transmitted/received between the eNBs and UEs to which the eNB provides the service also increases. Since the quantity of radio resource that can be used for the eNB to communicate with the UEs is finite, there is a need for a new method by which the ENB efficiently transmits/receives uplink/downlink data and/or uplink/downlink control information to/from UEs using finite radio resource.

25 **[5]** An object of the present invention devised to solve the problem lies on a new method for transmitting an uplink reference signal to support enhanced uplink transmission and a method for successfully receiving the uplink reference signal at an uplink signal receiver.

30

[6] The technical problems solved by the present invention are not limited to the above technical problems and those skilled in the art may understand other technical problems from the following description.

【Technical Solution】

5 [7] The object of the present invention can be achieved by providing a method for transmitting an uplink signal at a user equipment (UE) in a wireless communication system, the method including, when a parameter $N_{ID}^{csh_DMRS}$ for a reference signal for demodulation of a physical uplink shared channel (PUSCH) is provided, generating a sequence of the reference signal on the basis of $N_{ID}^{csh_DMRS}$, and transmitting the generated reference signal to
 10 an eNB, wherein, when $N_{ID}^{csh_DMRS}$ is provided, a pseudo-random sequence generator used to determine cyclic shift hopping of the reference signal is initialized according to

$$c_{init} = \left\lfloor \frac{N_{ID}^{csh_DMRS}}{30} \right\rfloor \cdot 2^5 + (N_{ID}^{csh_DMRS} \bmod 30)$$

at the start of each radio frame, wherein

c_{init} is an initial value of a pseudo-random sequence and mod denotes a modulo operation.

[8] In another aspect of the present invention, provided herein is a UE device for
 15 transmitting an uplink signal, including a receiver, a transmitter, and a processor, wherein, when a parameter $N_{ID}^{csh_DMRS}$ for a reference signal for demodulation of a physical uplink shared channel (PUSCH) is provided, the processor is configured to generate a sequence of the reference signal on the basis of $N_{ID}^{csh_DMRS}$ and to transmit the generated reference signal to an eNB, wherein, when $N_{ID}^{csh_DMRS}$ is provided, a pseudo-random sequence generator used
 20 to determine cyclic shift hopping of the reference signal is initialized according to

$$c_{init} = \left\lfloor \frac{N_{ID}^{csh_DMRS}}{30} \right\rfloor \cdot 2^5 + (N_{ID}^{csh_DMRS} \bmod 30)$$

at the start of each radio frame, wherein c_{init} is an initial value of a pseudo-random sequence and mod denotes a modulo operation.

[9] The following may be commonly applied to the above-described embodiments of the present invention.

25 [10] A virtual cell ID n_{ID}^{PUSCH} may be provided as an additional parameter for the UE in addition to $N_{ID}^{csh_DMRS}$.

[11] $N_{ID}^{csh_DMRS}$ may be used for cyclic shift hopping with respect to the reference

signal and n_{ID}^{PUSCH} may be used for one or more of a group hopping pattern, a sequence shift pattern and a sequence hopping pattern with respect to the reference signal.

[12] When n_{ID}^{PUSCH} is provided and sequence group hopping for the reference signal is enabled, a pseudo-random sequence generator used to determine a group hopping pattern

5 may be initialized according to $c_{init} = \left\lfloor \frac{n_{ID}^{PUSCH}}{30} \right\rfloor$.

[13] When n_{ID}^{PUSCH} is provided, a sequence shift pattern f_{ss}^{PUSCH} of the reference signal may be determined according to $f_{ss}^{PUSCH} = n_{ID}^{PUSCH} \bmod 30$.

[14] When n_{ID}^{PUSCH} is provided, sequence group hopping for the reference signal is disabled and sequence hopping is enabled, a pseudo-random sequence generator used to determine a base sequence number v may be initialized according to

10 $c_{init} = \left\lfloor \frac{n_{ID}^{PUSCH}}{30} \right\rfloor \cdot 2^5 + f_{ss}^{PUSCH}$ at the start of each radio frame.

[15] When n_{ID}^{PUSCH} is not provided, c_{init} may be determined according to

$$c_{init} = \left\lfloor \frac{N_{ID}^{cell}}{30} \right\rfloor, \text{ and } N_{ID}^{cell} \text{ may be a physical layer cell ID.}$$

[16] When n_{ID}^{PUSCH} is not provided, the sequence shift pattern f_{ss}^{PUSCH} of the reference signal may be determined according to $f_{ss}^{PUSCH} = (N_{ID}^{cell} + \Delta_{ss}) \bmod 30$, and Δ_{ss} may be set by a higher layer and $\Delta_{ss} \in \{0,1,\dots,29\}$.

[17] When n_{ID}^{PUSCH} is not provided, sequence group hopping for the reference signal is disabled and sequence hopping is enabled, a pseudo-random sequence generator used to determine a base sequence number v may be initialized according to

20 $c_{init} = \left\lfloor \frac{N_{ID}^{cell}}{30} \right\rfloor \cdot 2^5 + f_{ss}^{PUSCH}$ at the start of each radio frame.

[18] $N_{ID}^{csh_DMRS}$ and n_{ID}^{PUSCH} may be set by a higher layer.

[19] n_{ID}^{PUSCH} may be set one of 0 to 509.

[20] When $N_{ID}^{csh_DMRS}$ is not provided, a pseudo-random sequence generator used to determine cyclic shift hopping of the reference signal may be initialized according to

$$c_{init} = \left\lfloor \frac{N_{ID}^{cell}}{30} \right\rfloor \cdot 2^5 + ((N_{ID}^{cell} + \Delta_{ss}) \bmod 30)$$
 at the start of each radio frame, wherein

N_{ID}^{cell} is a physical layer cell ID, Δ_{ss} is set by a higher layer and $\Delta_{ss} \in \{0,1,\dots,29\}$.

5 [21] $N_{ID}^{csh_DMRS}$ may be set one of 0 to 509.

[22] The reference signal may be transmitted on an SC-FDMA (Single Carrier Frequency Division Multiple Access) symbol in a slot in which the PUSCH is transmitted.

[23] The technical problems solved by the present invention are not limited to the above technical problems and those skilled in the art may understand other technical
10 problems from the following description.

【Advantageous Effects】

[24] The present invention can provide a new method for transmitting an uplink reference signal to support enhanced uplink transmission and a method for successfully receiving the uplink reference signal at an uplink signal receiver.

15 [25] The effects of the present invention are not limited to the above-described effects and other effects which are not described herein will become apparent to those skilled in the art from the following description.

【Description of Drawings】

[26] The accompanying drawings, which are included to provide a further
20 understanding of the invention, illustrate embodiments of the invention and together with the description serve to explain the principle of the invention. In the drawings:

[27] FIG. 1 illustrates a radio frame structure;

[28] FIG. 2 illustrates a resource grid;

[29] FIG. 3 illustrates a downlink subframe structure;

25 [30] FIG. 4 illustrates an uplink subframe structure;

[31] FIG. 5 illustrates a downlink reference signal;

[32] FIGS. 6 to 10 illustrate UCI transmission using PUCCH (Physical Uplink Control Channel) format 1 series, PUCCH format 2 series and PUCCH format 3 series;

[33] FIG. 11 illustrates multiplexing of uplink control information and uplink data in
30 a PUSCH (Physical Uplink Shared Channel) region;

[34] FIG. 12 illustrates an exemplary UL CoMP operation;

[35] FIG. 13 is a flowchart illustrating an uplink reference signal transmission method according to an embodiment of the present invention; and

[36] FIG. 14 shows configurations of an eNB and a UE according to an embodiment of the present invention.

5 **【Best Mode】**

[37] Embodiments described hereinbelow are combinations of elements and features of the present invention. The elements or features may be considered selective unless otherwise mentioned. Each element or feature may be practiced without being combined with other elements or features. Further, an embodiment of the present invention may be
10 constructed by combining parts of the elements and/or features. Operation orders described in embodiments of the present invention may be rearranged. Some constructions of any one embodiment may be included in another embodiment and may be replaced with corresponding constructions of another embodiment.

[38] In the embodiments of the present invention, a description is made, centering
15 on a data transmission and reception relationship between a base station (BS) and a User Equipment (UE). The BS is a terminal node of a network, which communicates directly with a UE. In some cases, a specific operation described as performed by the BS may be performed by an upper node of the BS.

[39] Namely, it is apparent that, in a network comprised of a plurality of network
20 nodes including a BS, various operations performed for communication with a UE may be performed by the BS, or network nodes other than the BS. The term 'BS' may be replaced with the term 'fixed station', 'Node B', 'evolved Node B (eNode B or eNB)', 'Access Point (AP)', etc. The term 'UE' may be replaced with the term 'terminal', 'Mobile Station (MS)', 'Mobile Subscriber Station (MSS)', 'Subscriber Station (SS)', etc.

25 [40] Specific terms used for the embodiments of the present invention are provided to aid in understanding of the present invention. These specific terms may be replaced with other terms within the scope and spirit of the present invention.

[41] In some cases, to prevent the concept of the present invention from being
30 ambiguous, structures and apparatuses of the known art will be omitted, or will be shown in the form of a block diagram based on main functions of each structure and apparatus. Also, wherever possible, the same reference numbers will be used throughout the drawings and the specification to refer to the same or like parts.

[42] The embodiments of the present invention can be supported by standard documents disclosed for at least one of wireless access systems, Institute of Electrical and Electronics Engineers (IEEE) 802, 3rd Generation Partnership Project (3GPP), 3GPP Long Term Evolution (3GPP LTE), LTE-Advanced (LTE-A), and 3GPP2. Steps or parts that are not described to clarify the technical features of the present invention can be supported by those documents. Further, all terms as set forth herein can be explained by the standard documents.

[43] Techniques described herein can be used in various wireless access systems such as Code Division Multiple Access (CDMA), Frequency Division Multiple Access (FDMA), Time Division Multiple Access (TDMA), Orthogonal Frequency Division Multiple Access (OFDMA), Single Carrier-Frequency Division Multiple Access (SC-FDMA), etc. CDMA may be implemented as a radio technology such as Universal Terrestrial Radio Access (UTRA) or CDMA2000. TDMA may be implemented as a radio technology such as Global System for Mobile communications (GSM)/General Packet Radio Service (GPRS)/Enhanced Data Rates for GSM Evolution (EDGE). OFDMA may be implemented as a radio technology such as IEEE 802.11 (Wi-Fi), IEEE 802.16 (WiMAX), IEEE 802.20, Evolved-UTRA (E-UTRA) etc. UTRA is a part of Universal Mobile Telecommunication System (UMTS). 3GPP LTE is a part of Evolved UMTS (E-UMTS) using E-UTRA. 3GPP LTE employs OFDMA for downlink and SC-FDMA for uplink. LTE-A is an evolution of 3GPP LTE. WiMAX can be described by the IEEE 802.16e standard (Wireless Metropolitan Area Network (WirelessMAN-OFDMA Reference System) and the IEEE 802.16m standard (WirelessMAN-OFDMA Advanced System). For clarity, this application focuses on the 3GPP LTE/LTE-A system. However, the technical features of the present invention are not limited thereto.

[44] A radio frame structure of 3GPP LTE is described with reference to FIG. 1.

[45] In a cellular orthogonal frequency division multiplex (OFDM) wireless packet communication system, uplink/downlink data packet transmission is performed on a subframe basis and a subframe is defined as a predetermined time period including a plurality of OFDM symbols. 3GPP LTE supports a type 1 radio frame structure applicable to frequency division duplex (FDD) and a type 2 radio frame structure applicable to time division duplex (TDD).

[46] FIG. 1(a) illustrates the type 1 radio frame structure. A radio frame is divided into 10 subframes. Each subframe is further divided into two slots in the time domain. A unit time during which one subframe is transmitted is defined as a transmission time

interval (TTI). For example, one subframe may be 1ms in duration and one slot may be 0.5ms in duration. A slot may include a plurality of OFDM symbols in the time domain and a plurality of resource blocks in the frequency domain. Because 3GPP LTE adopts OFDMA for downlink, an OFDM symbol represents one symbol period. An OFDM symbol may be referred to as an SC-FDMA symbol or symbol period. A resource block (RB) is a resource allocation unit including a plurality of contiguous subcarriers in a slot.

[47] The number of OFDM symbols included in one slot may be changed according to the configuration of a cyclic prefix (CP). The CP includes an extended CP and a normal CP. For example, if the OFDM symbols are configured by the normal CP, the number of OFDM symbols included in one slot may be seven. If the OFDM symbols are configured by the extended CP, since the length of one OFDM symbol is increased, the number of OFDM symbols included in one slot is less than that of the case of the normal CP. In case of the extended CP, for example, the number of OFDM symbols included in one slot may be six. If the channel state is unstable, for example, if a UE moves at a high speed, the extended CP may be used in order to further reduce interference between symbols.

[48] FIG. 1(b) illustrates the type 2 radio frame structure. The type 2 radio frame includes two half-frames, each of which is made up of five subframes, a downlink pilot time slot (DwPTS), a guard period (GP), and an uplink pilot time slot (UpPTS), in which one subframe consists of two slots. DwPTS is used to perform initial cell search, synchronization, or channel estimation. UpPTS is used to perform channel estimation of a base station and uplink transmission synchronization of a UE. The guard interval (GP) is located between an uplink and a downlink so as to remove interference generated in the uplink due to multi-path delay of a downlink signal. One subframe is composed of two slots irrespective of the radio frame type.

[49] The radio frame structure is purely exemplary and thus the number of subframes in a radio frame, the number of slots in a subframe, or the number of symbols in a slot may vary.

[50] FIG. 2 illustrates a resource grid in a downlink slot. A downlink slot includes 7 OFDM symbols in the time domain and an RB includes 12 subcarriers in the frequency domain, which does not limit the scope and spirit of the present invention. For example, a downlink slot includes 7 OFDM symbols in case of a normal CP, whereas a downlink slot includes 6 OFDM symbols in case of an extended CP. Each element of the resource grid is referred to as a resource element (RE). An RB includes 12x7 REs. The number of RBs in a

downlink slot, N^{DL} depends on a downlink transmission bandwidth. An uplink slot may have the same structure as a downlink slot.

[51] Downlink subframe structure

[52] FIG. 3 illustrates a downlink subframe structure. Up to three OFDM symbols at the start of the first slot in a downlink subframe correspond to a control region to which control channels are allocated and the other OFDM symbols of the downlink subframe correspond to a data region to which a physical downlink shared channel (PDSCH) is allocated. Downlink control channels used in 3GPP LTE include a physical control format indicator channel (PCFICH), a physical downlink control channel (PDCCH), and a physical hybrid automatic repeat request (HARQ) indicator channel (PHICH). The PCFICH is located in the first OFDM symbol of a subframe, carrying information about the number of OFDM symbols used for transmission of control channels in the subframe. The PHICH delivers an HARQ acknowledgment/negative acknowledgment (ACK/NACK) signal in response to an uplink transmission. Control information carried on the PDCCH is called downlink control information (DCI). The DCI transports uplink or downlink scheduling information, or uplink transmission power control commands for UE groups. The PDCCH delivers information about resource allocation and a transport format for a downlink shared channel (DL-SCH), resource allocation information about an uplink shared channel (UL-SCH), paging information of a paging channel (PCH), system information on the DL-SCH, information about resource allocation for a higher-layer control message such as a random access response transmitted on the PDSCH, a set of transmission power control commands for individual UEs of a UE group, transmission power control information, voice over Internet protocol (VoIP) activation information, etc. A plurality of PDCCHs may be transmitted in the control region. A UE may monitor a plurality of PDCCHs. A PDCCH is formed by aggregation of one or more consecutive control channel elements (CCEs). A CCE is a logical allocation unit used to provide a PDCCH at a coding rate based on the state of a radio channel. A CCE includes a set of REs. The format of a PDCCH and the number of available bits for the PDCCH are determined according to the correlation between the number of CCEs and a coding rate provided by the CCEs. An eNB determines the PDCCH format according to DCI transmitted to a UE and adds a cyclic redundancy check (CRC) to control information. The CRC is masked by an identifier known as a radio network temporary identifier (RNTI) according to the owner or usage of the PDCCH. If the PDCCH is directed to a specific UE, its CRC may be masked by a cell-RNTI (C-RNTI) of the UE. If the PDCCH carries a paging message, the CRC of the PDCCH may be masked

by a paging indicator identifier (P-RNTI). If the PDCCH carries system information, particularly, a system information block (SIB), its CRC may be masked by a system information ID and a System Information RNTI (SI-RNTI). To indicate that the PDCCH carries a random access response in response to a random access preamble transmitted by a UE, its CRC may be masked by a random access-RNTI (RA-RNTI).

[53] Downlink reference signal

[54] When a packet is transmitted in a wireless communication system, signal distortion may occur during transmission because the packet is transmitted through a radio channel. To successfully receive a distorted signal at a receiver, it is necessary to correct distortion of the received signal using channel information. To detect the channel information, a method of transmitting a signal known to a transmitter and the receiver and detecting the channel information using a degree of distortion when the signal is received through the channel is widely used. The signal is called a pilot signal or a reference signal.

[55] In transmission and reception of data using multiple antennas, the receiver needs to know channel states between transmit antennas and receive antennas to successfully receive a signal. Accordingly, a separate reference signal is needed for each transmit antenna.

[56] Downlink reference signals include a common reference signal (CRS) shared by all UEs in a cell and a dedicated reference signal (DRS) for only a specific UE. Information for channel estimation and demodulation can be provided according to these reference signals. The CRS is used to estimate a channel of a physical antenna, can be commonly received by all UEs in a cell, and is distributed in the overall band. The CRS can be used for acquisition of channel state information (CSI) and data demodulation.

[57] A receiver (UE) can estimate a channel state from the CRS and feed back indicators regarding channel quality, such as a channel quality indicator (CQI), a precoding matrix index (PMI) and/or a rank indicator (RI), to a transmitter (eNB). The CRS may be called a cell-specific reference signal.

[58] The DRS can be transmitted through a corresponding RE when demodulation of data on a PDSCH is needed. The UE may receive information about presence or absence of a DRS from a higher layer and receive information representing that the DRS is valid only when a corresponding PDSCH is mapped. The DRS may also be called a UE-specific reference signal or modulation reference signal (DMRS). The DRS (or UE-specific reference signal) is used for data demodulation. A precoding weight used for a specific UE is used for the DRS during multi-antenna transmission such that an equivalent channel

corresponding a combination of a precoding weight transmitted through each transmit antenna and a transmission channel can be estimated when the UE receives the DRS.

[59] FIG. 4 illustrates a pattern of matching a CRS and a DRS defined in 3GPP LTE to a downlink RB pair. A downlink RB pair as a unit to which a reference signal is mapped can be represented by a product of one subframe in the time domain and 12 subcarriers in the frequency domain. That is, one RB pair has a length corresponding to 14 OFDM symbols in case of normal CP and a length corresponding to 12 OFDM symbols in case of extended CP. FIG. 4 shows an RB pair in case of normal CP.

[60] FIG. 4 shows positions of reference signals on an RB pair in a system in which an eNB supports four transmit antennas. In FIG. 4, REs denoted by 'R0', 'R1', 'R2' and 'R3' correspond to CRS positions for antenna port indexes 0, 1, 2 and 3. REs denoted by 'D' correspond to DRS positions.

[61] High-order MIMO (Multiple Input Multiple Output), multi-cell transmission, enhanced multi-user (MU)-MIMO, etc. are considered in LTE-A evolved from 3GPP LTE. To efficiently operate reference signals and support enhanced transmission schemes, DRS based data demodulation is being considered. That is, a DRS (or UE-specific reference signal or DMRS) for two or more layers can be defined to support data transmission through an additional antenna, separately from a DRS (corresponding to antenna port index 5) for rank 1 beamforming defined in 3GPP LTE (e.g. release-8). For example, UE-specific reference signal ports supporting up to 8 transmit antenna ports can be defined as antenna port numbers 7 to 12 and can be transmitted in REs which do not overlap with other reference signals.

[62] Furthermore, LTE-A may separately define an RS related to feedback of channel state information (CSI) such as CQI/PMI/RI for a new antenna port as a CSI-RS. For example, CSI-RS ports supporting up to 8 transmit antenna ports can be defined as antenna port numbers 15 to 22 and can be transmitted in REs which do not overlap with other reference signals.

[63] Uplink subframe structure

[64] FIG. 5 illustrates an uplink subframe structure.

[65] Referring to FIG. 5, an uplink subframe may be divided into a control region and a data region in the frequency domain. One or more Physical Uplink Control Channels (PUCCHs) carrying uplink control information may be allocated to the control region and one or more Physical Uplink Shared Channels (PUSCHs) carrying user data may be allocated to the data region.

[66] Subcarriers far from a direct current (DC) subcarrier are used for the control region in the UL subframe. In other words, subcarriers at both ends of an uplink transmission bandwidth are allocated for transmission of uplink control information. The DC subcarrier is a component that is spared from signal transmission and mapped to carrier frequency f_0 during frequency upconversion. A PUCCH from one UE is allocated to an RB pair in a subframe and the RBs of the RB pair occupy different subcarriers in two slots. This PUCCH allocation is called frequency hopping of an RB pair allocated to a PUCCH over a slot boundary. However, if frequency hopping is not applied, the RB pair occupies the same subcarriers.

10 [67] A PUCCH may be used to transmit the following control information.

[68] – SR (Scheduling Request): used to request UL-SCH resource. This information is transmitted using OOK (On-Off Keying) .

[69] – HARQ-ACK: response to a PDCCH and/or a response to a downlink data packet (e.g. codeword) on a PDSCH. This information represents whether the PDCCH or PDSCH has been successfully received. 1-bit HARQ-ACK is transmitted in response to a single downlink codeword and 2-bit HARQ-ACK is transmitted in response to two downlink codewords. HARQ-ACK responses include positive ACK (simply, ACK), negative ACK (NACK), DTX (Discontinuous Transmission) and NACK/DTX. Here, the term HARQ-ACK is used with HARQ ACK/NACK and ACK/NACK.

20 [70] – CSI (Channel State Information): This is feedback information about a downlink channel. MIMO-related feedback information includes an RI and a PMI.

[71] The quantity of UCI that can be transmitted by a UE in a subframe depends on the number of SC-FDMA symbols available for control information transmission. SC-FDMA symbols available for UCI correspond to SC-FDMA symbols other than SC-FDMA symbols used for reference signal transmission in a subframe. In the case of a subframe including a sounding reference signal (SRS), the SC-FDMA symbols available for UCI correspond to SC-FDMA symbols other than SC-FDMA symbols used for reference signal transmission and the last SC-FDMA symbol in the subframe. A reference signal is used for PUCCH coherent detection. A PUCCH supports various formats according to transmitted information.

30 [72] PUCCH format 1 is used to transmit SR, PUCCH format 1a/1b is used to transmit ACK/NACK information, and PUCCH format 2 is used to carry CSI such as CQI/PMI/RI. PUCCH format 2a/2b is used to carry ACK/NACK information with CSI and PUCCH format 3 series is used to transmit ACK/NACK information.

[73] UCI transmission

[74] FIGS. 6 to 10 illustrate UCI transmission using PUCCH format 1 series, PUCCH format 2 series and PUCCH format 3 series.

[75] In 3GPP LTE/LTE-A, a subframe having a normal CP is composed of two slots each of which includes seven OFDM symbols (or SC-FDMA symbols). A subframe having an extended CP is composed of two slots each of which includes six OFDM symbols (or SC-FDMA symbols). Since the number of OFDM symbols (or SC-FDMA symbols) per subframe depends on a CP length, a PUCCH transmission structure in a UL subframe is varied according to CP length. Accordingly, a method of transmitting UCI in a UL subframe by a UE is varied according to PUCCH format and CP length.

[76] Referring to FIGS. 6 and 7, in case of transmission using PUCCH formats 1a and 1b, the same control information is repeated on a slot basis in a subframe. UEs transmit ACK/NACK signals through different resources composed of different cyclic shifts (CSs) of a CG-CAZAC (Computer-Generated Constant Amplitude Zero Auto Correlation) sequence and orthogonal cover codes (OCC). A CS may correspond to a frequency domain code and an OCC may correspond to a time domain spreading code. An OCC may also be called an orthogonal sequence. An OCC includes a Walsh/DFT (Discrete Fourier Transform) orthogonal code, for example. When the number of CSs is 6 and the number of OCCs is 3, a total of 18 PUCCHs can be multiplexed in the same PRB (Physical Resource Block) on the basis of a single antenna port. An orthogonal sequence w_0 , w_1 , w_2 and w_3 may be applied in a time domain after FFT (Fast Fourier Transform) or in a frequency domain before FFT. A PUCCH resource for ACK/NACK transmission in 3GPP LTE/LTE-A is represented by a combination of the position of a time-frequency resource (e.g. PRB), a cyclic shift of a sequence for frequency spreading and an orthogonal code (or quasi-orthogonal code) for time spreading. Each PUCCH resource is indicated using a PUCCH resource index (PUCCH index). A slot level structure of PUCCH format 1 series for SR transmission is identical to that of PUCCH formats 1a and 1b and a modulation method thereof is different.

[77] FIG. 8 illustrates transmission of CSI in a UL slot having a normal CP using PUCCH format 2a/2b/2c and FIG. 9 illustrates transmission of CSI in a UL slot having an extended CP using PUCCH format 2a/2b/2c.

[78] Referring to FIGS. 8 and 9, in case of the normal CP, a UL subframe is composed of 10 SC-FDMA symbols excepting symbols carrying UL reference signals (RSs). CSI is coded into 10 transmission symbols (which may be called complex-valued

modulation symbols) through block coding. The 10 transmission symbols are respectively mapped to 10 SC-FDMA symbols and transmitted to an eNB.

[79] PUCCH format 1/1a/1b and PUCCH format 2/2a/2b can carry only UCI having up to a predetermined number of bits. However, as the quantity of UCI increases due to introduction of carrier aggregation, a TDD system, a relay system and a multi-node system and an increase in the number of antennas, a PUCCH format, which is called PUCCH format 3, capable of carrying a larger quantity of UCI than PUCCH formats 1/1a/1b/2/2a/2b, is introduced. For example, PUCCH format 3 can be used for a UE for which carrier aggregation is set to transmit a plurality of ACK/NACK signals for a plurality of PDSCHs, received from an eNB through a plurality of downlink carriers, through a specific uplink carrier.

[80] PUCCH format 3 may be configured on the basis of block spreading, for example. Referring to FIG. 10, block spreading time-domain-spreads a symbol sequence using an OCC (or orthogonal sequence) and transmits the spread symbol sequence. According to block spreading, control signals of a plurality of UEs can be multiplexed to the same RB and transmitted to an eNB. In the case of PUCCH format 2, one symbol sequence is transmitted over the time domain, and UCI of UEs is multiplexed using a CS of a CAZAC sequence and transmitted to an eNB. In the case of a new PUCCH format based on block spreading (e.g. PUCCH format 3), one symbol sequence is transmitted over the frequency domain, and UCI of UEs is multiplexed using OCC based time-domain spreading and transmitted to the eNB. Referring to FIG. 8, one symbol sequence is spread using an OCC having length-5 (that is, SF=5) and mapped to 5 SC-FDMA symbols. While FIG. 10 illustrates a case in which two RS symbols are used in one slot, 3 RS symbols may be used and an OCC with SF=4 can be used for symbol sequence spreading and UE multiplexing. Here, the RS symbols can be generated from a CAZAC sequence having a specific CS. A specific OCC can be applied to/multiplied by the RS symbols and then the RS symbols can be transmitted to the eNB. In FIG. 10, DFT may be applied prior to OCC, and FFT (Fast Fourier Transform) may replace DFT.

[81] In FIGS. 6 to 10, a UL RS transmitted with UCI on a PUCCH can be used for the eNB to demodulate the UCI.

[82] FIG. 11 illustrates multiplexing of UCI and uplink data in a PUSCH region.

[83] The uplink data can be transmitted in a data region of a UL subframe through a PUSCH. A UL DMRS (Demodulation Reference Signal) corresponding to an RS for demodulation of the uplink data can be transmitted with the uplink data in the data region of

the UL subframe. The control region and the data region in the UL subframe are respectively called a PUCCH region and a PUSCH region.

[84] When UCI needs to be transmitted in a subframe to which PUSCH transmission is assigned, a UE multiplexes the UCI and uplink data (referred to as PUSCH data hereinafter) prior to DFT-spreading and transmits the multiplexed UL signal over a PUSCH if simultaneous transmission of the PUSCH and a PUCCH is not allowed. The UCI includes at least one of CQI/PMI, HARQ ACK/NACK and RI. The number of REs used to transmit each of CQI/PMI, HARQ ACK/NACK and RI is based on a modulation and coding scheme (MCS) and an offset value ($\Delta_{\text{offset}}^{\text{CQI}}$, $\Delta_{\text{offset}}^{\text{HARQ-ACK}}$, $\Delta_{\text{offset}}^{\text{RI}}$) allocated for PUSCH transmission. The offset value allows different coding rates according to UCI and is semi-statically set through higher layer (e.g. radio resource control (RRC)) signaling. The PUSCH data and UCI are not mapped to the same RE. The UCI is mapped such that it is present in both slots of the subframe.

[85] Referring to FIG. 11, CQI and/or PMI resource is located at the start of the PUSCH data, sequentially mapped to all SC-FDMA symbols in one subcarrier and then mapped to the next subcarrier. The CQI/PMI is mapped to a subcarrier from the left to the right, that is, in a direction in which the SC-FDMA symbols index increases. The PUSCH data is rate-matched in consideration of the quantity of a CQI/PMI resource (that is, the number of coded symbols). The same modulation order as that of UL-SCH data is used for the CQI/PMI. ACK/NACK is inserted into part of SC-FDMA resource to which the UL-SCH data is mapped through puncturing. The ACK/NACK is located beside a PUSCH RS for demodulation of the PUSCH data and sequentially occupies corresponding SC-FDMA symbols from bottom to top, that is, in a direction in which the subcarrier index increases. In a normal CP case, SC-FDMA symbols for the ACK/NACK correspond to SC-FDMA symbols #2/#5 in each slot, as shown in FIG. 11. Coded RI is located beside a symbol for ACK/NACK irrespective of whether the ACK/NACK is actually transmitted in the subframe.

[86] In 3GPP LTE, UCI may be scheduled such that it is transmitted over a PUSCH without PUSCH data. Multiplexing ACK/NACK, RI and CQI/PMI is similar to that illustrated in FIG. 11. Channel coding and rate matching for control signaling without PUSCH data correspond to those for the above-described control signaling having PUSCH data.

[87] In FIG. 11, the PUSCH RS can be used to demodulate the UCI and/or the PUSCH data transmitted in the PUSCH region. In the present invention, a UL RS related to PUCCH transmission and a PUSCH RS related to PUSCH transmission are commonly called a DMRS.

5 [88] A sounding reference signal (SRS) (not shown) may be allocated to the PUSCH region. The SRS is a UL RS that is not related to transmission of a PUSCH or PUCCH. The SRS is transmitted on the last SC-FDMA symbol of a UL subframe in the time domain and transmitted in a data transmission band of the UL subframe, that is, a PUSCH region in the frequency domain. An eNB can measure an uplink channel state between a UE and the
 10 eNB using the SRS. SRSs of a plurality of UEs, which are transmitted/received on the last SC-FDMA symbol of the same subframe, can be discriminated according to frequency positions/sequences thereof.

[89] Uplink reference signal

[90] A DMRS transmitted in a PUCCH region and a DMRS and an SRS transmitted
 15 in a PUSCH region can be regarded as uplink UE-specific RSs because they are UE-specifically generated by a specific UE and transmitted to an eNB.

[91] A UL RS is defined by a cyclic shift of a base sequence according to a predetermined rule. For example, an RS sequence $r_{u,v}^{(\alpha)}(n)$ is defined by a cyclic shift α of a base sequence $r_{u,v}(n)$ according to the following equation.

20 [92] [Equation 1]

$$r_{u,v}^{(\alpha)}(n) = e^{j\alpha n} \cdot r_{u,v}(n), \quad 0 \leq n < M_{sc}^{RS}$$

[93] Here, M_{sc}^{RS} is the length of the RS sequence, $M_{sc}^{RS} = m \cdot N_{sc}^{RB}$ and $1 \leq m \leq N_{RB}^{max,UL}$. $N_{RB}^{max,UL}$ represented by a multiple of N_{sc}^{RB} refers to a widest uplink bandwidth configuration. N_{sc}^{RB} denotes the size of an RB and is represented by the number of
 25 subcarriers. A plurality of RS sequences can be defined from a base sequence through different cyclic shift values α . A plurality of base sequences is defined for a DMRS and an SRS. For example, the base sequences are defined using a root Zadoff-Chu sequence. Base sequences $r_{u,v}(n)$ are divided into two groups each of which includes one or more base sequences. For example, each base sequence group can include one base sequence having a
 30 length of $M_{sc}^{RS} = m \cdot N_{sc}^{RB}$ ($1 \leq m \leq 5$) and two base sequences having a length of $M_{sc}^{RS} = m \cdot N_{sc}^{RB}$ ($6 \leq m \leq N_{sc}^{RB}$). As to $r_{u,v}(n)$, $u \in \{0, 1, \dots, 29\}$ denotes a group number (that is, group index) and v denotes a base sequence number (that is, base sequence index) in the corresponding

group. Each base sequence group number and a base sequence number in the corresponding group may be varied with time.

[94] The sequence group number u in a slot n_s is defined by a group hopping pattern $f_{gh}(n_s)$ and a sequence shift pattern f_{ss} according to the following equation.

5 [95] [Equation 2]

$$u = (f_{gh}(n_s) + f_{ss}) \bmod 30$$

[96] In Equation 2, mod refers to a modulo operation. A mod B means a remainder obtained by dividing A by B.

[97] A plurality of different hopping patterns (e.g. 30 hopping patterns) and a plurality of different sequence shift patterns (e.g. 17 sequence shift patterns) are present. Sequence group hopping may be enabled or disabled according to a cell-specific parameter provided by a higher layer.

[98] The group hopping pattern $f_{gh}(n_s)$ can be provided by a PUSCH and a PUCCH according to the following equation.

15 [99] [Equation 3]

$$f_{gh}(n_s) = \begin{cases} 0 & \text{if group hopping is disabled} \\ \left(\sum_{i=0}^7 c(8n_s + i) \cdot 2^i \right) \bmod 30 & \text{if group hopping is enabled} \end{cases}$$

[100] Here, a pseudo-random sequence $c(i)$ can be defined by a length-31 Gold sequence. An output sequence $c(n)$ ($n=0, 1, \dots, M_{PN}-1$) having a length of M_{PN} is defined according to the following equation.

20 [101] [Equation 4]

$$\begin{aligned} c(n) &= (x_1(n + N_C) + x_2(n + N_C)) \bmod 2 \\ x_1(n + 31) &= (x_1(n + 3) + x_1(n)) \bmod 2 \\ x_2(n + 31) &= (x_2(n + 3) + x_2(n + 2) + x_2(n + 1) + x_2(n)) \bmod 2 \end{aligned}$$

[102] Here, $N_C=1600$ and the first m-sequence is initialized to $x_1(0)=1$, $x_1(n)=0$, $n=1,2,\dots,30$. Initialization of the second m-sequence is represented by the following equation having a value depending on application of the sequence.

25 [103] [Equation 5]

$$c_{\text{init}} = \sum_{i=0}^{30} x_2(i) \cdot 2^i$$

[104] In Equation 3, a pseudo-random sequence generator is initialized to c_{init} at the start of each radio frame according to the following equation.

[105] [Equation 6]

$$c_{init} = \left\lfloor \frac{N_{ID}^{cell}}{30} \right\rfloor$$

5 [106] In Equation 6, $\lfloor \cdot \rfloor$ denotes floor operation and $\lfloor A \rfloor$ is a maximum integer less than or equal to A.

[107] According to 3GPP LTE, a PUCCH and a PUSCH have different sequence shift patterns although they have the same group hopping pattern according to Equation 3. A sequence shift pattern f_{ss}^{PUCCH} for the PUCCH is provided on the basis of cell
10 identification information (cell ID) according to the following equation.

[108] [Equation 7]

$$f_{ss}^{PUCCH} = N_{ID}^{cell} \bmod 30$$

[109] A sequence shift pattern f_{ss}^{PUSCH} for the PUSCH is given according to the following equation using the sequence shift pattern f_{ss}^{PUCCH} for the PUCCH and a value Δ_{ss}
15 configured by a higher layer.

[110] [Equation 8]

$$f_{ss}^{PUSCH} = (f_{ss}^{PUCCH} + \Delta_{ss}) \bmod 30$$

[111] Here, $\Delta_{ss} \in \{0, 1, \dots, 29\}$.

[112] Base sequence hopping is applied only to RSs having a length of $M_{sc}^{RS} \geq 6N_{sc}^{RB}$.
20 For RSs having a length of $M_{sc}^{RS} \geq 6N_{sc}^{RB}$, the base sequence number v in a base sequence group is 0. For RSs having a length of $M_{sc}^{RS} < 6N_{sc}^{RB}$, the base sequence number v in a base sequence group in the slot n_s is defined as $v=c(n_s)$ when group hopping is disabled and sequence hopping is enabled and defined as $v=0$ in other cases. Here, the pseudo-random sequence $c(i)$ is given by Equation 4. The pseudo-random sequence generator is initialized
25 to c_{init} at the start of each radio frame according to the following equation.

[113] [Equation 9]

$$c_{init} = \left\lfloor \frac{N_{ID}^{cell}}{30} \right\rfloor \cdot 2^5 + f_{ss}^{PUSCH}$$

[114] A sequence $r_{\text{PUCCH}}^{(p)}(\cdot)$ of the UL RS (PUCCH DMRS) in FIGS. 6 to 10 is given by the following equation.

[115] [Equation 10]

$$r_{\text{PUCCH}}^{(p)}\left(m' N_{\text{RS}}^{\text{PUCCH}} M_{\text{sc}}^{\text{RS}} + m M_{\text{sc}}^{\text{RS}} + n\right) = \frac{1}{\sqrt{P}} \bar{w}^{(p)}(m) z(m) r_{u,v}^{(\alpha-p)}(n)$$

5 [116] Here, $m=0, \dots, N_{\text{RS}}^{\text{PUCCH}}-1$, $n=0, \dots, M_{\text{sc}}^{\text{RS}}-1$, and $m'=0, 1$. $N_{\text{RS}}^{\text{PUCCH}}$ denotes the number of reference symbols per slot for the PUCCH and P denotes the number of antenna ports used for PUCCH transmission. A sequence $r_{u,v}^{(\alpha-p)}(n)$ is given by Equation 1 having $M_{\text{sc}}^{\text{RS}}=12$, and a cyclic shift $\alpha-p$ is determined by a PUCCH format.

[117] All PUCCH formats use a cell-specific CS, $n_{\text{cs}}^{\text{cell}}(n_s, l)$ which has a value
 10 depending on a symbol number l and a slot number n_s and is determined as

$$n_{\text{cs}}^{\text{cell}}(n_s, l) = \sum_{i=0}^7 c(8N_{\text{symb}}^{\text{UL}} \cdot n_s + 8l + i) \cdot 2^i$$
 Here, the pseudo-random sequence $c(i)$ is initialized at the start of each radio frame according to $c_{\text{init}} = N_{\text{ID}}^{\text{cell}}$.

[118] As to PUCCH formats 2a and 2B, $z(m)$ corresponds to $d(10)$ when $m=1$, and $z(m)=1$ in other cases. For PUCCH formats 2a and 2b supported for only the normal CP,
 15 UCI bits $b(20), \dots, b(M_{\text{bit}}-1)$ from among $b(0), \dots, b(M_{\text{bit}}-1)$ are modulated into a single modulation symbol $d(10)$ used to generate a reference signal for PUCCH formats 2a and 2b, as shown in Table 1.

[119] [Table 1]

PUCCH format	$b(20), \dots, b(M_{\text{bit}}-1)$	$d(10)$
2a	0	1
	1	-1
2b	00	1
	01	-j
	10	j
	11	-1

20 [120] The PUSCH RS (referred to as PUSCH DMRS hereinafter) in FIG. 11 is transmitted on a layer basis. A PUSCH DMRS sequence $r_{\text{PUSCH}}^{(p)}(\cdot)$ related to layer $\lambda \in \{0, 1, \dots, v-1\}$ is given by the following equation.

[121] [Equation 11]

$$r_{\text{PUSCH}}^{(\lambda)}(m \cdot M_{\text{sc}}^{\text{RS}} + n) = w^{(\lambda)}(m) r_{u,v}^{(\alpha - \lambda)}(n)$$

[122] Here, $m=0,1$, $n=0,\dots,M_{\text{sc}}^{\text{RS}}-1$, and $M_{\text{sc}}^{\text{RS}}=M_{\text{sc}}^{\text{PUSCH}}$. $M_{\text{sc}}^{\text{PUSCH}}$ is a bandwidth scheduled for uplink transmission and denotes the number of subcarriers. An orthogonal sequence $w^{(\lambda)}(m)$ can be given by Table 2 using a cyclic shift field in latest uplink-related DCI for transport blocks related to the corresponding PUSCH. Table 2 illustrates mapping of a cyclic shift field in an uplink-related DCI format to $n_{\text{DMRS},\lambda}^{(2)}$ and $[w^{(\lambda)}(0) w^{(\lambda)}(1)]$.

[123] [Table 2]

Cyclic Shift Field in uplink-related DCI format	$n_{\text{DMRS},\lambda}^{(2)}$				$[w^{(\lambda)}(0) w^{(\lambda)}(1)]$			
	$\lambda = 0$	$\lambda = 1$	$\lambda = 2$	$\lambda = 3$	$\lambda = 0$	$\lambda = 1$	$\lambda = 2$	$\lambda = 3$
000	0	6	3	9	[1 1]	[1 1]	[1 -1]	[1 -1]
001	6	0	9	3	[1 -1]	[1 -1]	[1 1]	[1 1]
010	3	9	6	0	[1 -1]	[1 -1]	[1 1]	[1 1]
011	4	10	7	1	[1 1]	[1 1]	[1 1]	[1 1]
100	2	8	5	11	[1 1]	[1 1]	[1 1]	[1 1]
101	8	2	11	5	[1 -1]	[1 -1]	[1 -1]	[1 -1]
110	10	4	1	7	[1 -1]	[1 -1]	[1 -1]	[1 -1]
111	9	3	0	6	[1 1]	[1 1]	[1 -1]	[1 -1]

[124] A cyclic shift $\alpha_{-\lambda}$ in the slot n_s is given as $2\pi n_{\text{cs},\lambda} / 12$. Here, $n_{\text{cs},\lambda} = (n_{\text{DMRS}}^{(1)} + n_{\text{DMRS},\lambda}^{(2)} + n_{\text{PN}}(n_s)) \bmod 12$ where $n_{\text{DMRS}}^{(1)}$ is given by Table 3 according to a cyclic shift parameter provided through higher layer signaling. Table 3 shows mapping of cyclic shifts to $n_{\text{DMRS}}^{(1)}$ according to higher layer signaling.

[125] [Table 3]

cyclicShift	$n_{\text{DMRS}}^{(1)}$
0	0
1	2
2	3
3	4
4	6
5	8
6	9
7	10

[126] Furthermore, $n_{\text{PN}}(n_s)$ is given by the following equation using the cell-specific pseudo-random sequence $c(i)$.

[127] [Equation 12]

$$n_{\text{PN}}(n_s) = \sum_{i=0}^7 c(8N_{\text{symb}}^{\text{UL}} \cdot n_s + i) \cdot 2^i$$

[128] Here, the pseudo-random sequence $c(i)$ is defined by Equation 4. The pseudo-random sequence generator is initialized to c_{init} at the start of each radio frame according to the following equation.

[129] [Equation 13]

$$c_{init} = \left\lfloor \frac{N_{ID}^{cell}}{30} \right\rfloor \cdot 2^5 + f_{ss}^{PUSCH}$$

5

[130] An SRS sequence $r_{SRS}^{(p)}(n) = r_{u,v}^{(\alpha_p)}(n)$ is defined by Equation 1. Here, u denotes the PUCCH sequence group number above-described with respect to group hopping and v denotes the base sequence number above-described with respect to sequence hopping. The cyclic shift α_p of the SRS is given as follows.

10 [131] [Equation 14]

$$\alpha_p = 2\pi \frac{n_{SRS}^{cs,p}}{8}$$

$$n_{SRS}^{cs,p} = \left(n_{SRS}^{cs} + \frac{8p}{N_{ap}} \right) \bmod 8$$

$$p \in \{0, 1, \dots, N_{ap} - 1\}$$

[132] Here, $n_{SRS}^{cs} = \{0, 1, 2, 3, 4, 5, 6, 7\}$ is a value configured for each UE by higher layer parameters and separately generated by different higher layer parameters for configurations of periodic sounding and non-periodic sounding. N_{ap} denotes the number of
15 antenna ports used for SRS transmission.

[133] Coordinated Multi-Point: CoMP

[134] CoMP transmission/reception scheme (which is also referred to as co-MIMO, collaborative MIMO or network MIMO) is proposed to meet enhanced system performance requirements of 3GPP LTE-A. CoMP can improve the performance of a UE located at a
20 cell edge and increase average sector throughput.

[135] In a multi-cell environment having a frequency reuse factor of 1, the performance of a UE located at a cell edge and average sector throughput may decrease due to inter-cell interference (ICI). To reduce ICI, a conventional LTE system uses a method for allowing a UE located at a cell edge in an interfered environment to have appropriate
25 throughput using a simple passive scheme such as fractional frequency reuse (FFR) through UE-specific power control. However, it may be more preferable to reduce ICI or reuse ICI

as a signal that a UE desires rather than decreasing frequency resource use per cell. To achieve this, CoMP can be applied.

[136] CoMP applicable to downlink can be classified into joint processing (JP) and coordinated scheduling/beamforming (CS/CB).

5 [137] According to the JP, each point (eNB) of a CoMP coordination unit can use data. The CoMP coordination unit refers to a set of eNBs used for a coordinated transmission scheme. The JP can be divided into joint transmission and dynamic cell selection.

10 [138] The joint transmission refers to a scheme through which PDSCHs are simultaneously transmitted from a plurality of points (some or all CoMP coordination units). That is, data can be transmitted to a single UE from a plurality of transmission points. According to joint transmission, quality of a received signal can be improved coherently or non-coherently and interference on other UEs can be actively erased.

15 [139] Dynamic cell selection refers to a scheme by which a PDSCH is transmitted from one point (in a CoMP coordination unit). That is, data is transmitted to a single UE from a single point at a specific time, other points in the coordination unit do not transmit data to the UE at the time, and the point that transmits the data to the UE can be dynamically selected.

20 [140] According to the CS/CB scheme, CoMP coordination units can collaboratively perform beamforming of data transmission to a single UE. Here, user scheduling/beamforming can be determined according to coordination of cells in a corresponding CoMP coordination unit although data is transmitted only from a serving cell.

25 [141] In case of uplink, coordinated multi-point reception refers to reception of a signal transmitted according to coordination of a plurality of points geographically spaced apart from one another. A CoMP reception scheme applicable to uplink can be classified into joint reception (JR) and coordinated scheduling/beamforming (CS/CB).

[142] JR is a scheme by which a plurality of reception points receives a signal transmitted over a PUSCH and CS/CB is a scheme by which user scheduling/beamforming is determined according to coordination of cells in a corresponding CoMP coordination unit while one point receives a PUSCH.

30 [143] A UE can receive data from multi-cell base stations collaboratively using the CoMP system. The base stations can simultaneously support one or more UEs using the same radio frequency resource, improving system performance. Furthermore, a base station

may perform space division multiple access (SDMA) on the basis of CSI between the base station and a UE.

[144] In the CoMP system, a serving eNB and one or more collaborative eNBs are connected to a scheduler through a backbone network. The scheduler can operate by receiving channel information about a channel state between each UE and each collaborative eNB, measured by each eNB, through the backbone network. For example, the scheduler can schedule information for collaborative MIMO operation for the serving eNB and one or more collaborative eNBs. That is, the scheduler can directly direct collaborative MIMO operation to each eNB.

[145] As described above, the CoMP system can be regarded as a virtual MIMO system using a group of a plurality of cells. Basically, a communication scheme of MIMO using multiple antennas can be applied to CoMP.

[146] Enhanced uplink signal transmission scheme

[147] Referring to Equations 1 to 14, UEs located in a cell initialize the pseudo-random sequence generator that generates RS sequences using the same N_{ID}^{cell} . Because a UE transmits an uplink signal only to one cell, the UE uses only one N_{ID}^{cell} in order to generate a PUSCH DMRS, PUCCH DMRS and SRS. That is, in a conventional system in which a UE transmits an uplink signal only to one cell, a UE based DMRS sequence is used. In other words, since the conventional communication system performs uplink transmission only for one cell, a UE can acquire N_{ID}^{cell} (i.e. physical layer cell ID) on the basis of a downlink PSS (Primary Synchronization Signal) received from the serving cell and use the acquired N_{ID}^{cell} to generate an uplink RS sequence.

[148] However, in uplink CoMP, a UE can transmit an uplink signal to a plurality of cells or reception points (RPs) or to some of the cells or RPs. In this case, when an uplink transmitting side transmits an RS sequence generated according to a conventional method, a receiving side may not detect the RS.

[149] Accordingly, for CoMP in which a plurality of cells or RPs participates in communication with a UE, it is necessary to define DMRS generation, resource allocation and/or transmission schemes for data transmitted to different points even if the different points do not simultaneously receive the data. While one RP can receive an uplink signal from a UE through one or more cells, a cell receiving an uplink signal is called an RP in the following description for convenience.

[150] The present invention proposes a method by which a CoMP UE generates a DMRS sequence used for PUSCH transmission and/or PUCCH transmission in a multi-cell (multi-RP) environment.

[151] FIG. 1 is a diagram for explaining an exemplary UL CoMP operation.

5 [152] In an uplink CoMP operation by which one UE (i.e. CoMP UE) transmits a PUSCH to a plurality of cells (or RPs), it is important to ensure mutual orthogonality between uplink DMRSs. If mutual orthogonality between uplink DMRSs is not ensured, each RP cannot correctly estimate an uplink channel, and thus PUSCH demodulation performance is considerably deteriorated. The UE can generate a DMRS base sequence
10 using the cell ID of a serving cell and apply an OCC for orthogonality with other DMRSs as necessary. Specifically, the uplink DMRS base sequence is a function of the cell ID, and a PUSCH DMRS base sequence index having an offset of Δ_{ss} from a PUCCH DMRS base sequence index is determined. Here, Δ_{ss} is given through higher layer signaling (e.g. RRC signaling). That is, the same cell ID is applied to generation of base sequences of PUCCH
15 DMRS and PUSCH DMRS and a base sequence index offset of Δ_{ss} is provided between the base sequences of PUCCH DMRS and PUSCH DMRS (refer to Equation 8). For example, if $\Delta_{ss}=0$ is signaled through RRC signaling, the PUCCH DMRS and PUSCH DMRS may have the same base sequence.

[153] In case of the CoMP UE, a DL serving cell and a UL serving cell may be
20 different from each other, and thus the cell ID of the DL serving cell cannot be used to generate a UL DMRS base sequence and the UL DMRS base sequence needs to be generated using the cell ID of an RP according to determination by a scheduler. That is, the UL DMRS base sequence needs to be generated using the ID of a cell other than the serving cell. To provide scheduling flexibility in determination of UEs paired for MU-MIMO, it is
25 desirable to dynamically indicate a cell ID used to generate a UL DMRS. For example, a higher layer can signal setting of a plurality of DMRSs (including setting of a DMRS for cell A and setting of a DMRS for cell B) to a CoMP UE located at edges of a cell A and a cell B shown in FIG. 12. The CoMP UE may be co-scheduled with another UE (UE-A) of the cell A or another UE (UE-B) of the cell B according to channel condition and/or other
30 network conditions. That is, a DMRS base sequence of the CoMP UE can be generated using the ID of a cell to which a UE co-scheduled with the CoMP UE belongs. The cell ID used for DMRS base sequence generation can be dynamically selected or indicated.

[154] To support the above-described uplink CoMP operation, the present invention can provide a cell ID to be used to generate a PUSCH DMRS sequence to a UE through UE-specific higher layer signaling (e.g. RRC signaling). The cell ID used to generate the PUSCH DMRS sequence can be indicated using a parameter such as $N_{ID}^{(PUSCH)}$ or $n_{ID}^{(PUSCH)}$ to be discriminated from a cell ID (that is, a parameter N_{ID}^{cell} representing a physical layer cell ID (PCI)) used to generate a conventional DMRS sequence. Here, $N_{ID}^{(PUSCH)}$ or $n_{ID}^{(PUSCH)}$ may be called a virtual cell ID (VCI) for PUSCH DMRS sequence generation. The virtual cell ID (referred to as "PUSCH DMRS VCI") for PUSCH DMRS sequence generation may have a value identical to or different from the PCI.

[155] According to the conventional operation, a sequence shift pattern f_{ss}^{PUSCH} for the PUSCH DMRS is determined using a sequence shift pattern f_{ss}^{PUCCH} for the PUCCH and the sequence shift related offset Δ_{ss} set by a higher layer (refer to Equations 7 and 8). When f_{ss}^{PUCCH} of Equation 7 is applied to Equation 8, the following equation 15 is obtained.

[156] [Equation 15]

$$f_{ss}^{PUSCH} = ((N_{ID}^{cell} \bmod 30) + \Delta_{ss}) \bmod 30 = (N_{ID}^{cell} + \Delta_{ss}) \bmod 30$$

[157] When use of the PUSCH DMRS VCI parameter (e.g. $N_{ID}^{(PUSCH)}$ or $n_{ID}^{(PUSCH)}$) is set by a higher layer, the offset Δ_{ss} set by the higher layer may be used in the present invention. This may be called a first scheme for setting Δ_{ss} .

[158] Furthermore, when use of the PUSCH DMRS VCI parameter (e.g. $N_{ID}^{(PUSCH)}$ or $n_{ID}^{(PUSCH)}$) is set by the higher layer, the present invention may generate a PUSCH DMRS sequence using a predetermined (or pre-appointed) specific offset value Δ_{ss} instead of the offset Δ_{ss} set by the higher layer. That is, when the higher layer signals the PUSCH DMRS VCI parameter (e.g. $N_{ID}^{(PUSCH)}$ or $n_{ID}^{(PUSCH)}$) to a UE, the UE can be configured to use the predetermined offset Δ_{ss} instead of the offset Δ_{ss} previously used by the UE (or set by the higher layer). This may be called a second scheme for setting Δ_{ss} .

[159] As an example of the second scheme for setting Δ_{ss} , the present invention may previously determine a rule such that operation is performed on the basis of $\Delta_{ss}=0$ when the higher layer sets use of the PUSCH DMRS VCI parameter $N_{ID}^{(PUSCH)}$ or $n_{ID}^{(PUSCH)}$. This may be called a third scheme for setting Δ_{ss} .

[160] For example, the PUSCH DMRS VCI parameter $N_{ID}^{(PUSCH)}$ or $n_{ID}^{(PUSCH)}$ can replace the physical cell ID parameter N_{ID}^{cell} and Δ_{ss} can be set to 0 in Equation 15. This is arranged as follows.

[161] [Equation 16]

$$f_{ss}^{PUSCH} = N_{ID}^{(PUSCH)} \bmod 30 \text{ or}$$

$$f_{ss}^{PUSCH} = n_{ID}^{(PUSCH)} \bmod 30$$

[162] A plurality of PUSCH DMRS VCI values $N_{ID}^{(PUSCH)}$ or $n_{ID}^{(PUSCH)}$ may be set by the higher layer and a value to be used from among the plurality of PUSCH DMRS VCI values $N_{ID}^{(PUSCH)}$ or $n_{ID}^{(PUSCH)}$ may be dynamically indicated through uplink scheduling grant information (that is, uplink-related DCI). Here, when the PUSCH DMRS VCI values $N_{ID}^{(PUSCH)}$ or $n_{ID}^{(PUSCH)}$ are set by the higher layer, specific values Δ_{ss} respectively mapped to the PUSCH DMRS VCI values may be used.

[163] To dynamically indicate one of the PUSCH DMRS VCI values $N_{ID}^{(PUSCH)}$ or $n_{ID}^{(PUSCH)}$ through the uplink-related DCI, a bit (or bits) for indicating a virtual cell ID may be newly added to the uplink-related DCI format to explicitly indicate the corresponding VCI or an existing bit (or bits) may be reused. For example, a mapping relationship can be established such that one of states of a 3-bit "Carrier Indicator" field or a 3-bit "Cyclic Shift for DMRS and OCC index" field from among bit fields of the uplink-related DCI (e.g. DCI format 0 or 4) implicitly indicates one of the PUSCH DMRS VCI values $N_{ID}^{(PUSCH)}$ or $n_{ID}^{(PUSCH)}$.

[164] A case in which the PUSCH DMRS VCI $N_{ID}^{(PUSCH)}$ or $n_{ID}^{(PUSCH)}$ is set by the higher layer has been described in the above embodiment. The present invention proposes a scheme for setting/providing a virtual cell ID (referred to as "PUCCH DMRS VCI") used to generate a PUCCH DMRS sequence through UE-specific higher layer signaling (e.g. RRC signaling). A PUCCH DMRS VCI parameter may be indicated by $N_{ID}^{(PUSCH)}$ or $n_{ID}^{(PUSCH)}$.

[165] While the same cell ID (i.e. physical cell ID parameter N_{ID}^{cell}) is used to generate a PUSCH DMRS sequence and a PUCCH DMRS sequence in conventional operations, the present invention proposes a scheme of separately (independently) setting the PUSCH DMRS VCI (that is, $N_{ID}^{(PUSCH)}$ or $n_{ID}^{(PUSCH)}$) and the PUCCH DMRS VCI (that is, $N_{ID}^{(PUCCH)}$ or $n_{ID}^{(PUCCH)}$).

[166] For simplicity, the PUSCH DMRS VCI and the PUCCH DMRS VCI may be represented as one parameter n_{ID}^{RS} . In this case, n_{ID}^{RS} can be determined according to transmission type. That is, n_{ID}^{RS} can be defined as $n_{ID}^{(PUSCH)}$ in case of PUSCH related transmission and n_{ID}^{RS} can be defined as $n_{ID}^{(PUCCH)}$ in case of PUCCH related transmission.

5 Here, while one parameter n_{ID}^{RS} is used, $n_{ID}^{(PUSCH)}$ (or $N_{ID}^{(PUSCH)}$) and $n_{ID}^{(PUCCH)}$ (or $n_{ID}^{(PUCCH)}$) are defined as separate parameters. That is, it should be understood that $n_{ID}^{(PUSCH)}$ (or $N_{ID}^{(PUSCH)}$) and $n_{ID}^{(PUCCH)}$ (or $n_{ID}^{(PUCCH)}$) can be set by a higher layer as separate parameters.

[167] A case in which a PUCCH related VCI (that is, $n_{ID}^{(PUCCH)}$ or $N_{ID}^{(PUCCH)}$) and a PUSCH related VCI (that is, $n_{ID}^{(PUSCH)}$ or $N_{ID}^{(PUSCH)}$) are different from each other may
10 represent that a UE respectively transmits a PUCCH and a PUSCH to different RPs. That is, the PUCCH may be transmitted to an RP (or RPs) corresponding to $n_{ID}^{(PUCCH)}$ or $N_{ID}^{(PUCCH)}$ and the PUSCH may be transmitted to an RP (or RPs) corresponding to $n_{ID}^{(PUSCH)}$ or $N_{ID}^{(PUSCH)}$.

[168] A plurality of PUCCH DMRS VCI values $N_{ID}^{(PUCCH)}$ or $n_{ID}^{(PUCCH)}$ may be set by
15 the higher layer and a value to be used from among the plurality of PUCCH DMRS VCI values $N_{ID}^{(PUCCH)}$ or $n_{ID}^{(PUCCH)}$ may be dynamically indicated through uplink-related DCI. To dynamically indicate one of the PUCCH DMRS VCI values, a method of implicitly indicating a PUCCH DMRS VCI through a state of a specific bit field of an uplink-related DCI format or a method of adding a new bit field (or bit fields) to explicitly indicate a
20 PUCCH DMRS DCI may be used. For example, a mapping relationship can be established such that one of states of "HARQ process number" field (which is defined as 3 bits in case of FDD and 4 bits in case of TDD) of an uplink-related DCI format (e.g. DCI format 0 or 4) implicitly indicates one of the PUCCH DMRS VCI values. Otherwise, a mapping relationship can be established such that one of states of a bit field (e.g. downlink DMRS
25 sequence generation can be performed using a scrambling ID value indicated by 3-bit "Antenna port(s), scrambling identity and number of layers" field), which indicates a downlink DMRS (or UE-specific RS) parameter in DCI (e.g. DCI format 2C) for downlink allocation, implicitly indicates one of the PUCCH DMRS VCI values.

[169] The above-described embodiment of the present invention is represented by
30 equations as follows.

[170] When the pseudo-random sequence $c(i)$ used to determine the group hopping pattern $f_{gh}(n_s)$ of an uplink DMRS is generated according to Equations 3 and 6, the present invention can initialize the pseudo-random sequence generator to c_{init} at the start of each radio frame according to the following equation. That is, Equation 6 can be replaced by

[171] [Equation 17]

$$c_{init} = \left\lfloor \frac{n_{ID}^{RS}}{30} \right\rfloor$$

where $n_{ID}^{RS} = n_{ID}^{(PUSCH)}$ or $n_{ID}^{RS} = N_{ID}^{(PUSCH)}$ for a PUSCH, and $n_{ID}^{RS} = n_{ID}^{(PUCCH)}$ or $n_{ID}^{RS} = N_{ID}^{(PUCCH)}$ for a PUCCH.

[172] Equation 17 may be represented as Equation 18.

[173] [Equation 18]

$$c_{init} = \left\lfloor \frac{N_{ID}^{(PUSCH)}}{30} \right\rfloor \text{ or } c_{init} = \left\lfloor \frac{n_{ID}^{(PUSCH)}}{30} \right\rfloor \text{ for PUSCH, and}$$

$$c_{init} = \left\lfloor \frac{N_{ID}^{(PUCCH)}}{30} \right\rfloor \text{ or } c_{init} = \left\lfloor \frac{n_{ID}^{(PUCCH)}}{30} \right\rfloor \text{ for PUCCH}$$

[174] The sequence shift parameter f_{ss}^{PUCCH} for PUCCH DMRS can be represented by the following equation.

[175] [Equation 19]

$$f_{ss}^{PUCCH} = n_{ID}^{RS} \bmod 30$$

where $n_{ID}^{RS} = n_{ID}^{(PUCCH)}$ or $n_{ID}^{RS} = N_{ID}^{(PUCCH)}$ for a PUCCH.

[176] Equation 18 may be represented as Equation 20.

[177] [Equation 20]

$$f_{ss}^{PUCCH} = N_{ID}^{(PUCCH)} \bmod 30 \text{ or } f_{ss}^{PUCCH} = n_{ID}^{(PUCCH)} \bmod 30$$

[178] When the sequence shift parameter f_{ss}^{PUSCH} for PUSCH DMRS is determined, f_{ss}^{PUSCH} can be represented by Equation 21 when Δ_{ss} is predefined as 0 as represented by Equation 16.

[179] [Equation 21]

$$f_{ss}^{PUSCH} = n_{ID}^{RS} \bmod 30$$

where $n_{ID}^{RS} = n_{ID}^{(PUSCH)}$ or $n_{ID}^{RS} = N_{ID}^{(PUSCH)}$ for a PUSCH.

[180] Equation 21 may be represented as Equation 16 (that is, $f_{ss}^{PUSCH} = N_{ID}^{(PUSCH)} \bmod 30$ or $f_{ss}^{PUSCH} = n_{ID}^{(PUSCH)} \bmod 30$).

[181] Here, it should be noted that $n_{ID}^{(PUSCH)}$ (or $N_{ID}^{(PUSCH)}$) and $n_{ID}^{(PUCCH)}$ (or $n_{ID}^{(PUCCH)}$), which are different from each other, are actually applied as VCI values (i.e. n_{ID}^{RS}) although

5 f_{ss}^{PUCCH} and f_{ss}^{PUSCH} are defined in the same equation form in Equations 19 and 21.

[182] When the scheme (the third scheme for setting Δ_{ss}) represented by Equation 21 is applied, even if a value Δ_{ss} set through higher layer signaling has been provided to a corresponding UE, f_{ss}^{PUSCH} is calculated by setting Δ_{ss} to 0 when the PUSCH VCI (i.e. $n_{ID}^{(PUSCH)}$ or $N_{ID}^{(PUSCH)}$) is set by higher layer signaling.

10 [183] Alternatively, in determination of the sequence shift parameter f_{ss}^{PUSCH} for PUSCH DMRS, f_{ss}^{PUSCH} can be represented by Equation 22 when the value Δ_{ss} set by the higher layer is used (that is, the first scheme for setting Δ_{ss}) or a predetermined specific value Δ_{ss} is used (that is, the second scheme for setting Δ_{ss}).

[184] [Equation 22]

15
$$f_{ss}^{PUSCH} = \left\{ \left(n_{ID}^{RS} \bmod 30 \right) + \Delta_{ss} \right\} \bmod 30$$

where $n_{ID}^{RS} = n_{ID}^{(PUSCH)}$ or $n_{ID}^{RS} = N_{ID}^{(PUSCH)}$ for a PUSCH.

[185] In Equation 22, $\Delta_{ss} \in \{0, 1, \dots, 29\}$.

[186] Equation 22 may be represented as the following equation.

[187] [Equation 23]

20
$$f_{ss}^{PUSCH} = \left\{ \left(N_{ID}^{(PUSCH)} \bmod 30 \right) + \Delta_{ss} \right\} \bmod 30 \quad \text{or}$$

$$f_{ss}^{PUSCH} = \left\{ \left(n_{ID}^{(PUSCH)} \bmod 30 \right) + \Delta_{ss} \right\} \bmod 30$$

[188] According to the first scheme for setting Δ_{ss} , f_{ss}^{PUSCH} can be calculated using the value Δ_{ss} set by higher layer signaling and previously provided to the corresponding UE and the PUSCH VCI (that is, $n_{ID}^{(PUSCH)}$ or $N_{ID}^{(PUSCH)}$) signaled by the higher layer.

25 [189] According to the second scheme for setting Δ_{ss} , even if the value Δ_{ss} set by higher layer signaling has been provided to the corresponding UE, f_{ss}^{PUSCH} can be calculated by setting Δ_{ss} to a specific value s ($s \in \{0, 1, \dots, 29\}$) when the PUSCH VCI (that is, $n_{ID}^{(PUSCH)}$ or $N_{ID}^{(PUSCH)}$) is set through higher layer signaling.

[190] According to the above-described embodiments, a group hopping pattern $f_{gh}(n_s)$ of a UE for which a value A is set by a higher layer as a PUSCH DMRS VCI (that is, $n_{ID}^{(PUSCH)}$ or $N_{ID}^{(PUSCH)}$) corresponds to group hopping patterns of other UEs (that is, UEs for which a PCI is set to A and/or UEs for which a PUSCH VCI is set to A) using the value A as a cell ID. Furthermore, when the same Δ_{ss} (particularly, $\Delta_{ss}=0$) is applied to determination of the sequence shift pattern f_{ss}^{PUSCH} , the sequence shift pattern of the UE for which the PUSCH VCI is set corresponds to PUSCH DMRS sequence shift patterns of the other UEs. Accordingly, base sequence indexes u of UEs which use the same group hopping pattern and the same sequence shift pattern are identical (refer to Equation 2). This means that orthogonality can be given between DMRSs of the UEs by respectively applying different CSs to the UEs. That is, the present invention can provide orthogonality between PUSCH DMRSs of UEs belonging to different cells by setting a PUSCH DMRS VCI for a specific UE, distinguished from a conventional wireless communication system in which orthogonality between PUSCH DMRSs is given using different CSs in the same cell. Accordingly, MU-MIMO pairing for UEs belonging to different cells can be achieved and enhanced UL CoMP operation can be supported.

[191] Furthermore, even when different PUSCH DMRS VCI values are set for a plurality of UEs, orthogonality between PUSCH DMRSs can be provided by making the plurality of UEs use the same PUSCH DMRS base sequence.

[192] Specifically, the first, second and third schemes for setting Δ_{ss} correspond to a rule of determining a value Δ_{ss} to be used when the PUSCH DMRS VCI (that is, $n_{ID}^{(PUSCH)}$ or $N_{ID}^{(PUSCH)}$) is signaled by a higher layer. On the assumption that one of the schemes is applied, an eNB can select an appropriate PUSCH DMRS VCI (that is, $n_{ID}^{(PUSCH)}$ or $N_{ID}^{(PUSCH)}$) in consideration of a value Δ_{ss} to be used and signal the selected PUSCH DMRS VCI to a UE. Here, c_{init} , which is a factor (or a seed value) for determining the group hopping pattern $f_{gh}(n_s)$, is determined as the same value for 30 different VCI values (that is, $n_{ID}^{(PUSCH)}$ or $N_{ID}^{(PUSCH)}$) according to a floor operation as represented by Equations 17 and 18. Accordingly, it is possible to set f_{ss}^{PUSCH} to a specific value by selecting an appropriate one of the 30 different VCI values generating the same group hopping pattern $f_{gh}(n_s)$. That is, group hopping patterns $f_{gh}(n_s)$ respectively calculated by two different UEs can be identical to each other even though different VCIs are set for the two UEs. Furthermore, sequence shift patterns f_{ss}^{PUSCH} respectively calculated by the two UEs can be identical to each other.

An appropriate VCI (that is, $n_{ID}^{(PUSCH)}$ or $N_{ID}^{(PUSCH)}$) that makes group hopping patterns $f_{gh}(n_s)$ and sequence shift patterns f_{ss}^{PUSCH} of MU-MIMO-paired UEs correspond to each other can be set through a higher layer. Accordingly, PUSCH DMRS base sequences of the UEs become identical, and thus orthogonality between PUSCH DMRSs can be provided according to a method of applying different CSs to the UEs.

[193] In addition, a plurality of UEs can have the same group hopping pattern $f_{gh}(n_s)$ and the same sequence shift pattern f_{ss}^{PUSCH} through a method of setting a UE-specific VCI (that is, $n_{ID}^{(PUSCH)}$ or $N_{ID}^{(PUSCH)}$) and/or a method of setting a UE-specific Δ_{ss} . Here, since a method of additionally higher-layer-signaling a value Δ_{ss} to each UE may generate unnecessary overhead, it is possible to make the UEs have the same group hopping pattern $f_{gh}(n_s)$ and the same sequence shift pattern f_{ss}^{PUSCH} by signaling only the UE-specific VCI without separately signaling Δ_{ss} .

[194] Alternatively, the PUSCH transmission related VCI (that is, $n_{ID}^{(PUSCH)}$ or $N_{ID}^{(PUSCH)}$) may be used only when f_{ss}^{PUSCH} is determined. That is, the PCI (that is, N_{ID}^{cell}) of the current serving cell is used for f_{ss}^{PUCCH} , as represented by Equation 7, and the VCI (that is, $n_{ID}^{(PUSCH)}$ or $N_{ID}^{(PUSCH)}$) proposed by the present invention is used for f_{ss}^{PUSCH} to separate a PUCCH sequence and a PUSCH sequence from each other.

[195] Alternatively, $N_{ID}^{(PUSCH)}$ may also be applied to f_{ss}^{PUCCH} . That is, f_{ss}^{PUCCH} can be defined by Equation 24.

[196] [Equation 24]

$$f_{ss}^{PUCCH} = N_{ID}^{(PUSCH)} \bmod 30 \text{ or } f_{ss}^{PUCCH} = n_{ID}^{(PUSCH)} \bmod 30$$

[197] Equation 24 represents that a UE-specific VCI (N_{ID}) is set by higher layer signaling and commonly used to determine f_{ss}^{PUCCH} and f_{ss}^{PUSCH} . That is, a PUCCH and a PUSCH are transmitted from a corresponding UE to an RP (or RPs) using a UE-specific N_{ID} by setting the UE-specific N_{ID} .

[198] The scope of the present invention is not limited to the above-described embodiments and can include various methods for allowing UEs to have the same PUSCH DMRS sequence group hopping pattern $f_{gh}(n_s)$ and/or the same shift pattern f_{ss}^{PUSCH} by setting a UE-specific VCI.

[199] When group hopping is disabled and sequence hopping is enabled, sequence hopping according to a conventional method can be defined as represented by Equation 9. As proposed by the present invention, when a UE-specific VCI (that is, $n_{ID}^{(PUSCH)}$ or

$N_{ID}^{(PUSCH)}$) is set by a higher layer and sequence hopping is enabled, the pseudo-random sequence generator can be initialized to c_{init} at the start of each radio frame according to the following equation.

[200] [Equation 25]

$$c_{init} = \left\lfloor \frac{n_{ID}^{RS}}{30} \right\rfloor \cdot 2^5 + f_{ss}^{PUSCH}$$

where $n_{ID}^{RS} = n_{ID}^{(PUSCH)}$ or $n_{ID}^{RS} = N_{ID}^{(PUSCH)}$ for a PUSCH.

[201] The VCI (that is, n_{ID}^{RS} ($n_{ID}^{RS} = n_{ID}^{(PUSCH)}$ or $n_{ID}^{RS} = N_{ID}^{(PUSCH)}$ for PUSCH transmission)) used in Equation 25 may correspond to the PUSCH DMRS VCI signaled to the UE through higher layer signaling, which is described in the other embodiments. In addition, f_{ss}^{PUSCH} in Equation 25 may correspond to the value determined according to Equation 16, 21, 22 or 23 (that is, a value determined according to the first, second or third scheme for setting Δ_{ss}).

[202] Specifically, n_{ID}^{RS} and f_{ss}^{PUSCH} in Equation 25 can use the same values as n_{ID}^{RS} and f_{ss}^{PUSCH} determined to make group hopping patterns $f_{gh}(n_s)$ and sequence hopping patterns f_{ss}^{PUSCH} set for MU-MIMO-paired UE equal to each other when the third scheme (that is, a scheme of determining Δ_{ss} as 0 without additional higher layer signaling for setting Δ_{ss}) for setting Δ_{ss} is applied.

[203] Scheme of setting range of virtual cell ID value

[204] As described above, the first VCI (e.g. $n_{ID}^{(PUCCH)}$ or $N_{ID}^{(PUCCH)}$) for the PUCCH DMRS and the second VCI (e.g. $n_{ID}^{(PUSCH)}$ or $N_{ID}^{(PUSCH)}$) for the PUSCH DMRS can be provided as separate parameters.

[205] Here, the first VCI (e.g. $n_{ID}^{(PUCCH)}$ or $N_{ID}^{(PUCCH)}$) for the PUCCH DMRS can be set to one of 504 values (i.e. 0 to 503) like the PCI. In the conventional wireless communication system, the sequence shift pattern f_{ss}^{PUCCH} for a PUCCH is calculated

without using Δ_{ss} according to Equation 7, $f_{ss}^{PUCCH} = N_{ID}^{cell} \bmod 30$. When the first VCI (e.g. $n_{ID}^{(PUCCH)}$ or $N_{ID}^{(PUCCH)}$) for a PUCCH is set through higher layer signaling according to the present invention, f_{ss}^{PUCCH} is calculated without using Δ_{ss} according to Equation 20, $f_{ss}^{PUCCH} = N_{ID}^{(PUCCH)} \bmod 30$ or $f_{ss}^{PUCCH} = n_{ID}^{(PUCCH)} \bmod 30$. Accordingly,

sequence shift operation can be successfully supported even when the range of the first VCI for a PUCCH is limited to 0 to 503 as the PCI.

[206] When the second VCI (e.g. $n_{ID}^{(PUSCH)}$ or $N_{ID}^{(PUSCH)}$) for a PUSCH has the same range as that of the PCI, sequence shift for the PUSCH DMRS cannot be successfully supported. In the conventional wireless communication system, the sequence shift pattern

$$f_{ss}^{PUSCH} = \left(f_{ss}^{PUCCH} + \Delta_{ss} \right) \bmod 30$$

for a PUSCH is calculated without using Δ_{ss} according to Equation 8, . According to the scheme (particularly, the third scheme for setting Δ_{ss}) proposed by the present invention, however, when the second VCI

(e.g. $n_{ID}^{(PUSCH)}$ or $N_{ID}^{(PUSCH)}$) for a PUSCH is set, f_{ss}^{PUSCH} is calculated without using Δ_{ss}

according to Equation 16, $f_{ss}^{PUSCH} = N_{ID}^{(PUSCH)} \bmod 30$ or $f_{ss}^{PUSCH} = n_{ID}^{(PUSCH)} \bmod 30$. The

scheme of using the PCI and Δ_{ss} in the conventional wireless communication system was employed in order to cover 30 base sequence groups and 17 sequence group hopping patterns. That is, the offset value Δ_{ss} was additionally used because all 510 (that is, 30

base sequence groups \times 17 sequence group hopping patterns) cases cannot be covered when

based on only the PCI since the range of the PCI is limited to 0 to 503. Accordingly, to determine f_{ss}^{PUSCH} using only the second VCI for a PUSCH without using Δ_{ss} , it is

necessary to correct the range of the second VCI (e.g. $n_{ID}^{(PUSCH)}$ or $N_{ID}^{(PUSCH)}$).

[207] Therefore, the present invention defines the range of the value of the second VCI (e.g. $n_{ID}^{(PUSCH)}$ or $N_{ID}^{(PUSCH)}$) as 0 to 509. In this case, it is possible to cover all the 510

(30 \times 17) cases according to different base sequence groups and different sequence group hopping patterns.

[208] Definition/setting/provision of the first VCI (e.g. $n_{ID}^{(PUCCH)}$ or $N_{ID}^{(PUCCH)}$) for the PUCCH DMRS and the second VCI (e.g. $n_{ID}^{(PUSCH)}$ or $N_{ID}^{(PUSCH)}$) for the PUSCH DMRS as

separate parameters may mean that the available range (i.e. 0 to 503) of the first VCI and the available range (i.e. 0 to 509) of the second VCI are different from each other.

[209] In addition, the VCI range may be set such that it includes at least 0 to 509 in order to cover 510 (=30 \times 17) different pattern using a single VCI.

[210] For example, the VCI range can be set to 0 to 511 considering that at least 9 bits are necessary to represent 509 states because 9 bits can indicate a maximum of 512

states.

[211] Furthermore, the VCI range can be increased to 0 to 1023, which supports a bit width of 10 bits capable of representing 1024 states. If one or more of group hopping, sequence shift, sequence hopping and CS hopping require a new pattern, an increased VCI range can be defined and used.

5 [212] UE operation relating to uplink reference signal generation

[213] A scheme (referred to as a scheme A hereinafter) for supporting backward compatibility) in consideration of operation of a UE (referred to as legacy-UE hereinafter) according to the legacy wireless communication system and a scheme (referred to as a scheme B hereinafter) optimized for operation of a UE (advanced-UE (A-UE)) according to
10 an advanced wireless communication system will be described in detail on the basis of the above-described uplink reference signal generation scheme according to the present invention.

[214] The scheme A can be considered to be related to the first scheme (i.e. scheme of using Δ_{ss} set by a higher layer without change) for setting Δ_{ss} and the scheme B can be
15 considered to be related to the second or third scheme (i.e. scheme of ignoring Δ_{ss} set by a higher layer and using a specific value of Δ_{ss} (particularly, $\Delta_{ss} = 0$) for setting Δ_{ss} . However, the schemes A and B are not limited to the first, second and third schemes for setting Δ_{ss} .

[215] Scheme A

20 [216] An uplink reference signal generation operation capable of supporting backward compatibility with the legacy wireless communication system and UE operation will now be described. A UE can acquire the cell-specific parameter Δ_{ss} for UL RS sequence generation during initial cell access such as a random access procedure through higher layer signaling. In addition, the UE can acquire the PCI (that is, N_{ID}^{cell}) of the
25 corresponding cell on the basis of PSS and SSS.

[217] The UE can calculate f_{ss}^{PUSCH} for PUSCH transmission using the acquired PCI and Δ_{ss} (refer to Equation 8), and thus the UE can calculate a cyclic shift hopping (CSH) pattern of a PUSCH DMRS (refer to Equations 12 and 13). Here, an initial value c_{init}^{CSH} of a pseudo-random sequence $c(i)$ that determines the CSH pattern can be represented by
30 Equation 26 when f_{ss}^{PUSCH} in Equation 13 is replaced by f_{ss}^{PUSCH} in equation 8 and f_{ss}^{PUCCH} in Equation 6 is replaced by f_{ss}^{PUCCH} in equation 7.

[218] [Equation 26]

$$\begin{aligned}
c_{init}^{CSH} &= \left\lfloor \frac{N_{ID}^{cell}}{30} \right\rfloor \cdot 2^5 + ((N_{ID}^{cell} \bmod 30) + \Delta_{ss}) \bmod 30 \\
&= \left\lfloor \frac{N_{ID}^{cell}}{30} \right\rfloor \cdot 2^5 + ((N_{ID}^{cell} + \Delta_{ss}) \bmod 30)
\end{aligned}$$

[219] That is, the UE can acquire a parameter set $\{\text{PCI}, \Delta_{ss}, c_{init}^{CSH}\}$ in the initial access procedure and thus can generate a UL RS sequence.

5 [220] Scheme A-1

[221] PUCCH DMRS, PUSCH DMRS and SRS sequences can be generated by applying the parameter set $\{\text{PCI}, \Delta_{ss}, c_{init}^{CSH}\}$ to Equations 1 to 14. Here, since the PCI corresponds to N_{ID}^{cell} , the above description of Equations 1 to 14 can be equally applied and thus redundant description is omitted for clarity.

10 [222] Scheme A-2

[223] In addition, a UL RS generation operation of the UE, proposed by the present invention, when VCI and CSH pattern seed values are provided to the UE will now be described.

[224] For example, $\{\text{VCI}(m), c_{init}^{CSH}(m)\}$ ($m=0, 1, 2, \dots$) may be provided to the UE at a specific time through UE-specific higher layer signaling (e.g. RRC signaling). Here, m is a parameter set index. For example, when M PUCCH DMRS setting sets are present and m indicates one of the M sets, m can have one of values of 0 to $M-1$. If L PUSCH DMRS setting sets are present and m indicates one of the L sets, m can have one of values of $M, M+1, \dots, M+L-1$. When N SRS setting sets are present and m indicates one of the N sets, m can have one of values of $M+L, M+L+1, \dots, M+L+N-1$.

[225] Here, a plurality of sets of $\{\text{VCI}(m), c_{init}^{CSH}(m)\}$ can be semi-statically provided through higher layer signaling, and the value of the specific index m indicating one of the sets, which will be used by the UE, can be dynamically signaled (e.g. L1/L2 signaled).

[226] It is assumed that the number of PUCCH DMRS setting sets is $M=1$ in the following description. That is, while a plurality of PUCCH DMRS setting sets can be given and one of the sets can be dynamically switched and applied, it is assumed that a VCI for PUCCH DMRS generation is determined as $\text{VCI}^{\text{PUCCH}} = \text{VCI}(0)$ and a seed value for a CSH pattern of the PUCCH DMRS is determined as $c_{init}^{CSH-\text{PUCCH}} = c_{init}^{CSH}(0)$ using a set $\{\text{VCI}(0), c_{init}^{CSH}(0)\}$ corresponding to a semi-statically set index $m=0$ for the PUCCH DMRS in the

following description. Here, semi-static setting of $\{VCI(0), c_{init}^{CSH}(0)\}$ corresponding to $m=0$ means that $\{VCI(0), c_{init}^{CSH}(0)\}$ can be changed at a relatively long interval. Since a PUCCH is a control channel for stably carrying UCI, semi-static DMRS sequence change can be preferable. However, the present invention does not exclude provision of UE-specific higher layer signaling to set a PUCCH DMRS according to a scheme using M of larger than 2.

[227] According to a conventional scheme, c_{init}^{CSH} for a PUCCH DMRS was defined as $c_{init}^{CSH_PUCCH} = PCI$. When VCI^{PUCCH} is provided to the UE, the present invention provides $c_{init}^{CSH_PUCCH}$ defined separately (or independently) of VCI^{PUCCH} through UE-specific higher layer signaling, instead of determining $c_{init}^{CSH_PUCCH}$ as $c_{init}^{CSH_PUCCH} = VCI^{PUCCH}$ according to the conventional scheme. Accordingly, even when different values of VCI^{PUCCH} are set for MU-MIMO-paired UEs (the same base sequence can be determined even if different values of VCI^{PUCCH} are set), an OCC can be applied to DMRSs of the paired UEs to provide orthogonality by setting the same $c_{init}^{CSH_PUCCH}$. That is, according to the present invention, VCI^{PUCCH} and $c_{init}^{CSH_PUCCH}$, which are independent parameters, can be set through UE-specific higher layer signaling, and thus MU-MIMO pairing (particularly, inter-cell UE pairing) using an OCC can be supported.

[228] An operation of the UE to generate a UL RS when $M=1$ (i.e. the number of PUCCH DMRS setting sets is 1) and $L=1$ (i.e. the number of PUSCH DMRS setting sets is 1) will now be described. The following description is for clarity and the present invention can be equally applied to cases in which one or more of M , L and N have a value larger than 1.

[229] Scheme A-2-i

[230] When $M=1$ and $L=1$, $\{VCI(0), c_{init}^{CSH}(0)\}$ is defined as a PUCCH parameter set, as described above. Provision of $c_{init}^{CSH}(0)$ through higher layer signaling may mean that a PUCCH CSH pattern needs to be determined using $c_{init}^{CSH}(0)$ explicitly provided independently of $VCI(0)$. In this case, dynamic indication (or dynamic switching) between the PCI basically provided to the UE and the $VCI(0)$ may be signaled through a specific DCI format.

[231] When $c_{init}^{CSH}(0)$ is not provided through higher layer signaling and only VCI(0) is provided, $c_{init}^{CSH_PUCCH}$ can be determined as $c_{init}^{CSH_PUCCH} = VCI(0)$. In this case, dynamic indication between the PCI and VCI(0) may be signaled through a specific DCI format.

[232] Here, $\{VCI(1), c_{init}^{CSH}(1)\}$ is defined as a PUSCH DMRS parameter set because
 5 L=1. Provision of $c_{init}^{CSH}(1)$ through higher layer signaling may mean that a PUSCH CSH pattern needs to be determined using $c_{init}^{CSH}(1)$ explicitly given independently of VCI(1) instead of being based on VCI(1) as in the conventional method. In this case, dynamic indication between PUSCH parameter set $\{VCI(1), c_{init}^{CSH}(1)\}$ proposed by the present invention and the legacy parameter set $\{PCI, \Delta_{ss}, c_{init}^{CSH}\}$ may be signaled through uplink-
 10 related DCI.

[233] Scheme A-2-ii

[234] This scheme represents application of the scheme A-2-i as a mathematical expression when M=1 and L=1. That is, the following embodiments of the present invention can be regarded as schemes for supporting generation of a UL RS having
 15 backward compatibility with the legacy system in terms of UE operation. That is, in a system defining 3GPP LTE release-10, forms or calculation processes of equations (refer to description related to Equations 1 to 14) used for the UE to generate a UL RS are maintained without change and parameters applied to the equations are replaced by VCI(m), $f_{ss}^{PUCCH}(m)$, $c_{init}^{CSH}(m)$, etc. proposed by the present invention.

[235] Specifically, the group hopping pattern $f_{gh}(n_s)$ for a PUSCH and a PUCCH is defined as in Equation 3. However, the pseudo-random sequence $c(i)$ can be defined such

that it is initialized to $c_{init} = \left\lfloor \frac{VCI(m)}{30} \right\rfloor$ at the start of each radio frame by modifying

Equation 6. Here, VCI(0) may correspond to the first VCI for the PUCCH and VCI(1) may correspond to the second VCI for the PUSCH.

[236] The sequence shift pattern f_{ss} may be defined separately for the PUCCH and PUSCH. f_{ss}^{PUCCH} for the PUCCH (i.e. m=0) can be determined as

$f_{ss}^{PUCCH}(m) = VCI(m) \bmod 30$ by modifying Equation 7 and f_{ss}^{PUSCH} for the PUSCH (i.e.

m=1) can be determined as $f_{ss}^{PUSCH}(m) = (f_{ss}^{PUCCH}(m) + \Delta_{ss}) \bmod 30$ by modifying Equation

8. Here, $\Delta_{ss} \in \{0, 1, \dots, 29\}$, which can be set by a higher layer.

[237] While sequence hopping is applied only to RSs corresponding to $M_{sc}^{RS} \geq 6N_{sc}^{RB}$ as in the conventional scheme, the pseudo-random sequence generator with respect to sequence hopping can be defined such that it is initialized to

$$c_{init} = \left\lfloor \frac{VCI(m)}{30} \right\rfloor \cdot 2^5 + f_{ss}^{PUSCH} \text{ at the start of each radio frame by modifying Equation 9.}$$

5 [238] A cyclic shift value α_λ for the PUSCH (that is, $m=1$) in slot n_s is given as

$$\alpha_\lambda = 2\pi n_{cs,\lambda} / 12 \text{ where } n_{cs,\lambda} = (n_{DMRS}^{(1)} + n_{DMRS}^{(2)} + n_{PN}(n_s)) \bmod 12, \text{ as described with reference}$$

to Table 3. Here, a pseudo-random sequence generator for $n_{PN}(n_s)$ may be defined such that it is initialized at the start of each radio frame according to

$$c_{init}^{CSH_PUSCH} = \left\lfloor \frac{VCI(m)}{30} \right\rfloor \cdot 2^5 + f_{ss}^{PUSCH} \text{ or initialized according to } c_{init}^{CSH_PUSCH} = c_{init}^{CSH}(m) \text{ by}$$

10 modifying Equation 13.

[239] In addition, all PUCCH (i.e. $m=0$) formats use the cell-specific CS, $n_{cs}^{cell}(n_s, l)$.

$n_{cs}^{cell}(n_s, l)$ has different values according to a symbol number l and slot number n_s and is determined according to $n_{cs}^{cell}(n_s, l) = \sum_{i=0}^7 c(8N_{ymb}^{UL} \cdot n_s + 8l + i) \cdot 2^i$. Here, the pseudo-random sequence $c(i)$ can be defined such that it is initialized at the start of each radio frame

15 according to $c_{init}^{CSH_PUCCH} = VCI(m)$ or $c_{init}^{CSH_PUCCH} = c_{init}^{CSH}(m)$.

[240] Scheme A-2-iii

[241] It is assumed that $M=1$ and $L=1$ as described in the A-2-i and A-2-ii schemes.

According to the present scheme, a base sequence generated by the UE is identical to a base sequence generated by a UE' of a target cell. Particularly, the present scheme relates to a

20 method of determining a VCI such that the base sequence generated by the UE is identical to the base sequence generated by the UE' of the target cell while a network signals only the

VCI to the UE through higher layer signaling. For example, when a specific cell signals the PUSCH VCI(1) to the UE through higher layer signaling, if the UE' of the target cell uses

PCI' and Δ_{ss}' provided by the target cell and a base sequence of the UE', which is

25 generated according to $f_{ss}^{PUCCH'} = PCI' \bmod 30$ and $f_{ss}^{PUSCH'} = (f_{ss}^{PUCCH'} + \Delta_{ss}') \bmod 30$ is present, VCI(1) can be determined as follows.

[242] [Equation 27]

$$VCI(1) = \left(30 \times \left\lfloor \frac{PCI'}{30} \right\rfloor \right) + f_{ss}^{PUSCH}$$

[243] In addition, f_{ss}^{PUSCH} can be arranged as Equation 28.

[244] [Equation 28]

$$\begin{aligned} f_{ss}^{PUSCH} &= (f_{ss}^{PUSCH'} + 30 - \Delta_{ss}) \bmod 30 \\ &= (f_{ss}^{PUCCH'} + \Delta_{ss}' + 30 - \Delta_{ss}) \bmod 30 \\ &= (f_{ss}^{PUCCH'} + \Delta_{ss}' - \Delta_{ss}) \bmod 30 \end{aligned}$$

[245] When Equation 28 is applied to Equation 27, the following equation is obtained.

5 [246] [Equation 29]

$$VCI(1) = \left(30 \times \left\lfloor \frac{PCI'}{30} \right\rfloor \right) + (f_{ss}^{PUCCH'} + \Delta_{ss}' - \Delta_{ss}) \bmod 30$$

[247] When the eNB provides the value of VCI(1), determined according to Equation 29, to the UE, the UE can generate the same base sequence as that of the UE' of the specific target cell.

10 [248] The meaning of the above equation is as follows. $f_{ss}^{PUSCH'}$ of the cell to which

the UE' belongs equals $(f_{ss}^{PUCCH'} + \Delta_{ss}') \bmod 30$ and $f_{ss}^{PUCCH'} = PCI' \bmod 30$. $30 \times \left\lfloor \frac{PCI'}{30} \right\rfloor$

can be determined such that it has the same value as the integer part (or quotient) of $\frac{PCI'}{30}$

of the target cell to which the UE' belongs. In addition, $(f_{ss}^{PUCCH'} + \Delta_{ss}' - \Delta_{ss}) \bmod 30$ can be determined such that it has the same value as the modulo part (or remainder) of $\frac{PCI'}{30}$ of the

15 target cell to which the UE' belongs in order to consider Δ_{ss}' used by the target cell and to previously eliminate Δ_{ss} used as a cell-specific value in the cell to which the UE belongs.

When VCI(1) determined according to Equation 29 is signaled to the UE, the UE calculates

f_{ss}^{PUSCH} according to $f_{ss}^{PUSCH} = (\{VCI(1) \bmod 30\} + \Delta_{ss}) \bmod 30$ only by replacing n_{ID}^{cell} by

VCI(1) while using Equations 7 and 8. Here, when the UE calculates f_{ss}^{PUSCH} , Δ_{ss} is

20 eliminated and Δ_{ss}' is left and thus the UE can generate the same base sequence as that of the UE'.

[249] The above description of the scheme of setting a VCI for the UE of the specific cell such that the UE generates the same base sequence as that of the UE' of the target cell is exemplary. That is, various modifications or modified equations for determining a

25 modulo part of a VCI according to the scheme of previously eliminating Δ_{ss} of a cell to

which a CoMP UE belongs and the scheme of reflecting Δ_{ss} of the target cell are within the scope of the present invention.

[250] Scheme B

[251] Scheme B is applicable to the A-UE which is not limited to the conventional calculation method, according to the conventional scheme (e.g. scheme described with reference to Equations 1 to 14) or a scheme of newly defining only parameters of the conventional scheme.

[252] Scheme B-1

[253] The UE can acquire a parameter set $\{\text{PCI}, \Delta_{ss}, c_{init}^{CSH}\}$ in an initial access procedure and thus generate a UL RS sequence. Here, PUCCH DMRS, PUSCH DMRS and SRS sequences can be generated by applying the parameter set $\{\text{PCI}, \Delta_{ss}, c_{init}^{CSH}\}$ to Equations 1 to 14, as described in scheme A-1.

[254] Scheme B-2

[255] In addition, a UL RS generation operation of the UE when the UE receives $\{\text{VCI}(m), c_{init}^{CSH}(m)\}$ ($m=0, 1, 2, \dots$) at a specific time through UE-specific higher layer signaling (e.g. RRC signaling) is described below.

[256] Scheme B-2-i

[257] A UL RS generation operation of the UE on the assumption that $M=1$ (i.e. the number of PUCCH DMRS setting sets is 1) and $L=1$ (i.e. the number of PUSCH DMRS setting sets is 1) may be identical to that described in the scheme A-2-i. However, the principle of the present invention can be equally applied to cases in which one of M , L and N has a value of larger than 1.

[258] Scheme B-2-ii

[259] This scheme represents application of the scheme B-2-i as a mathematical expression when $M=1$ and $L=1$. That is, the following embodiments of the present invention relate to schemes defined differently from UE operation according to the legacy system. That is, the following embodiments relate to a method of calculating base sequence generation in a manner different from the conventional method rather than a method of using the conventional scheme (scheme described with reference to Equations 1 to 14) or newly defining (or replacing) only a parameter in the conventional scheme.

[260] Specifically, the group hopping pattern $f_{gh}(n_s)$ for a PUSCH and a PUCCH is defined as in Equation 3. However, the pseudo-random sequence $c(i)$ can be defined such

that it is initialized to $c_{init} = \left\lfloor \frac{VCI(m)}{30} \right\rfloor$ at the start of each radio frame by modifying Equation 6. Here, VCI(0) may correspond to the first VCI for the PUCCH and VCI(1) may correspond to the second VCI for the PUSCH.

[261] The sequence shift pattern f_{ss} may be defined separately for the PUCCH and PUSCH. f_{ss}^{PUCCH} for the PUCCH (i.e. $m=0$) can be determined as $f_{ss}^{PUCCH}(m) = VCI(m) \bmod 30$ by modifying Equation 7. f_{ss}^{PUSCH} for the PUSCH (i.e. $m=1$) can be determined as $f_{ss}^{PUSCH}(m) = VCI(m) \bmod 30$, different from Equation 8. That is, even if VCI(0) for the PUCCH and VCI(1) for the PUSCH are different from each other, $f_{ss}(m)$ for the PUCCH and PUSCH can be commonly defined as $f_{ss}(m) = VCI(m) \bmod 30$.

[262] While sequence hopping is applied only to RSs corresponding to $M_{sc}^{RS} \geq 6N_{sc}^{RB}$ as in the conventional scheme, the pseudo-random sequence generator with respect to sequence hopping can be defined such that it is initialized to $c_{init} = \left\lfloor \frac{VCI(m)}{30} \right\rfloor \cdot 2^5 + f_{ss}(m)$ at the start of each radio frame by modifying Equation 9.

[263] A cyclic shift value α_λ for the PUSCH (that is, $m=1$) in slot n_s is given as $\alpha_\lambda = 2\pi n_{cs,\lambda} / 12$ where $n_{cs,\lambda} = (n_{DMRS}^{(1)} + n_{DMRS,\lambda}^{(2)} + n_{PN}(n_s)) \bmod 12$, as described with reference to Table 3. Here, a pseudo-random sequence generator for $n_{PN}(n_s)$ may be defined such that it is initialized at the start of each radio frame according to $c_{init}^{CSH_PUSCH} = \left\lfloor \frac{VCI(m)}{30} \right\rfloor \cdot 2^5 + f_{ss}(m)$ or initialized according to $c_{init}^{CSH_PUSCH} = c_{init}^{CSH}(m)$ by modifying Equation 13.

[264] In addition, all PUCCH (i.e. $m=0$) formats use the cell-specific CS, $n_{cs}^{cell}(n_s, l)$. $n_{cs}^{cell}(n_s, l)$ has different values according to a symbol number l and slot number n_s and is determined according to $n_{cs}^{cell}(n_s, l) = \sum_{i=0}^7 c(8N_{symb}^{UL} \cdot n_s + 8l + i) \cdot 2^i$. Here, the pseudo-random sequence $c(i)$ can be defined such that it is initialized at the start of each radio frame according to $c_{init}^{CSH_PUCCH} = VCI(m)$ or $c_{init}^{CSH_PUCCH} = c_{init}^{CSH}(m)$.

[265] According to the scheme B-2-ii, the UL RS sequence generation operation of the UE can be simplified and optimized. For example, a new calculation method for determining the sequence shift pattern f_{ss} according to $f_{ss}(m) = VCI(m) \bmod 30$ is provided.

That is, if $VCI(m)$ is provided through RRC signaling, the operation may be represented on the assumption that $\Delta_{ss}=0$ all the time. In other words, the cell-specific value Δ_{ss} previously provided to the UE (i.e. previously set by a higher layer) is not used any more after the UE receives $VCI(m)$.

5 [266] Scheme B-2-iii

[267] It is assumed that $M=1$ and $L=1$ as described in the B-2-i and B-2-ii schemes. According to the present scheme, a base sequence generated by the UE is identical to a base sequence generated by a UE' of a target cell. Particularly, the present scheme relates to a method of determining a VCI such that the base sequence generated by the UE is identical
 10 to the base sequence generated by the UE' of the target cell while a network signals only the VCI to the UE through higher layer signaling. For example, when a specific cell signals the PUSCH VCI(1) to the UE through higher layer signaling, if the UE' of the target cell uses PCI' and Δ_{ss}' provided by the target cell and a base sequence of the UE', which is generated according to $f_{ss}^{PUCCH'} = PCI' \bmod 30$ and $f_{ss}^{PUSCH'} = (f_{ss}^{PUCCH'} + \Delta_{ss}') \bmod 30$ is
 15 present, VCI(1) can be determined as follows.

[268] [Equation 30]

$$\begin{aligned} VCI(1) &= \left(30 \times \left\lfloor \frac{PCI'}{30} \right\rfloor \right) + f_{ss}^{PUSCH} \\ &= \left(30 \times \left\lfloor \frac{PCI'}{30} \right\rfloor \right) + f_{ss}(m) \\ &= \left(30 \times \left\lfloor \frac{PCI'}{30} \right\rfloor \right) + VCI(1) \bmod 30 \end{aligned}$$

20 [269] When the eNB provides the value of VCI(1), determined according to Equation 30, to the UE, the UE can generate the same base sequence as that of the UE' of the specific target cell.

[270] The meaning of the above equation is described. $f_{ss}^{PUSCH'}$ of the cell to which the UE' belongs equals $(f_{ss}^{PUCCH'} + \Delta_{ss}') \bmod 30$ and $f_{ss}^{PUCCH'} = PCI' \bmod 30$. $30 \times \left\lfloor \frac{PCI'}{30} \right\rfloor$
 25 can be determined such that it has the same value as the integer part (or quotient) of $\frac{PCI'}{30}$ of the target cell to which the UE' belongs. In addition, $f_{ss}^{PUSCH'}$ is determined in consideration of only Δ_{ss}' (that is, UE assumes $\Delta_{ss}=0$ all the time) used in the target cell

such that f_{ss}^{PUSCH} has the same value as the modulo part (or remainder) of $\frac{PCI'}{30}$ of the target cell to which the UE' belongs. When VCI(1) determined according to Equation 30 is signaled to the UE, the UE can simply calculate f_{ss} according to $f_{ss}(m) = VCI(1) \bmod 30$ and can generate the same base sequence as that of the UE' because Δ_{ss}' has been reflected

5 in f_{ss} .

[271] The above description of the scheme of setting a VCI for the UE of the specific cell such that the UE generates the same base sequence as that of the UE' of the target cell is exemplary. That is, various modifications or modified equations for determining a modulo part of a VCI according to the scheme of reflecting only Δ_{ss}' of the target cell.

10 [272] In the embodiments for describing the schemes A and B, M, L and N may be arbitrary values and, when each of M, L and N is larger than 1, a specific one of a plurality of RS setting parameter sets corresponding thereto can be dynamically indicated (dynamically switched) through a DCI format.

[273] When N for SRS sequence generation is larger than 1, the CoMP UE can

15 generate a plurality of SRS sequences. Furthermore, even if M, L and N are larger than 1, the cell-specific parameter set (i.e. $\{PCI, \Delta_{ss}, c_{mit}^{CSH}\}$) of the corresponding cell, which is initially acquired by the UE, can be included in the dynamically indicated RS setting parameter sets such that the cell-specific parameter set is applied as a default set (i.e. applied in the form of a fall-back mode).

20 [274] VCI subdivision scheme

[275] The above-mentioned embodiments of the present invention have described the scheme of using a common VCI for a PUCCH and a PUSCH and the scheme of respectively using separate VCIs for the PUCCH and PUSCH when a UL RS base sequence is generated using a VCI.

25 [276] Additionally, the present invention proposes a scheme of setting and using an independent (or separate) VCI for subdivided purposes.

[277] For example, subdivided VCIs can be set in such manner that individual VCIs are respectively used for group hopping, sequence shift, sequence hopping, and cyclic shift hopping (CSH) when a PUSCH DMRS base sequence is generated. Otherwise, subdivided

30 VCIs can be set in such a manner that group hopping, sequence shift, sequence hopping and CSH operations are grouped into one or more groups and each group uses a common VCI. For example, group hopping/sequence hopping and sequence shift can use a common VCI

and CSH can use a separate VCI_{CSH} (or $N_{ID}^{csh_DMRS}$). VCIs subdivided in this manner may be set through higher layer signaling (e.g. RRC signaling) and each subdivided VCI may have a range of 0 to 509.

[278] Alternatively, subdivided VCIs can be set in such a manner that group hopping for a PUSCH, group hopping for a PUCCH, sequence shift for the PUSCH, sequence shift for the PUCCH, sequence hopping for the PUSCH, sequence hopping for the PUCCH, CSH for the PUSCH and CSH for the PUCCH can be grouped into one or more groups and each group can use a common VCI.

[279] For example, the same VCI (e.g. $N_{ID}^{(PUSCH)} \in \{0, \dots, 509\}$) can be commonly applied to Equation 18 (i.e. group hopping for each of a PUSCH and a PUCCH), Equation 20 (i.e. sequence shift for a PUCCH) and Equation 23 (i.e. the first or second scheme for sequence shift for a PUSCH). A separate VCI (e.g. $N_{ID,seq}^{(PUSCH)} \in \{0, \dots, 509\}$) can be set and used for Equation 25 (i.e. sequence hopping for a PUSCH) to generate an independent sequence hopping pattern, providing additional DMRS flexibility. Furthermore, another separate VCI (e.g. $N_{ID,seq}^{(PUSCH)} \in \{0, \dots, 509\}$ or $N_{ID}^{csh_DMRS} \in \{0, \dots, 509\}$) may be set and used for Equation 26 (i.e. CSH for a PUSCH) to generate an independent CSH to provide additional DMRS flexibility such as inter-cell MU-MIMO.

[280] Alternatively, the same VCI (e.g. $N_{ID}^{(PUSCH)} \in \{0, \dots, 509\}$) can be commonly applied to Equation 18, Equation 20, Equation 23 (or Equation 16) and Equation 25, whereas a separate VCI (e.g. $N_{ID,CSH}^{(PUSCH)} \in \{0, \dots, 509\}$ or $N_{ID}^{csh_DMRS} \in \{0, \dots, 509\}$) is set and used only for Equation 26 (i.e. CSH for a PUSCH) to generate independent CSH. In this case, Equation 26 can be modified into Equation 31.

[281] [Equation 31]

$$c_{init} = \left\lfloor \frac{N_{ID,CSH}^{(PUSCH)}}{30} \right\rfloor \cdot 2^5 + (N_{ID,CSH}^{(PUSCH)} \bmod 30) \text{ or}$$

$$c_{init} = \left\lfloor \frac{N_{ID}^{csh_DMRS}}{30} \right\rfloor \cdot 2^5 + (N_{ID}^{csh_DMRS} \bmod 30)$$

[282] When a parameter used for CSH is set separately from parameters used for other operations (e.g. group hopping/sequence hopping and/or sequence shift) for generating a base sequence as represented by Equation 31, the PCI needs to be replaced by a VCI (i.e. $N_{ID,CSH}^{(PUSCH)}$ or $N_{ID}^{csh_DMRS}$) and f_{ss}^{PUSCH} needs to be calculated in consideration of

the VCI (i.e. $N_{ID,CSH}^{(PUSCH)}$ or $N_{ID}^{csh_DMRS}$) in Equation 13 (i.e. the conventional scheme for an initial value of a pseudo-random sequence).

[283] Here, one of the first, second and third schemes for setting Δ_{ss} can be used to calculate f_{ss}^{PUSCH} as described above with reference to Equation 23 or Equation 16.

5 Equation 31 corresponds to a case in which $N_{ID}^{(PUSCH)}$ in $f_{ss}^{PUSCH} = N_{ID}^{(PUSCH)} \bmod 30$ is replaced by $N_{ID,CSH}^{(PUSCH)}$ (or $N_{ID}^{csh_DMRS}$).

[284] In case of sequence hopping, one of the first, second and third schemes for setting Δ_{ss} can be used to calculate f_{ss}^{PUSCH} of Equation 25, and a subdivided VCI (e.g. one of $N_{ID}^{(PUSCH)}$, $N_{ID,seq}^{(PUSCH)}$ and $N_{ID,CSH}^{(PUSCH)}$) can be applied.

10 [285] If the UE receives only one value of $N_{ID}^{(PUSCH)}$ through UE-specific higher layer signaling, a base sequence can be generated using the same value of $N_{ID}^{(PUSCH)}$ for Equation 18, Equation 20, Equation 23 (or Equation 16), Equation 25 and Equation 26.

[286] If the UE receives a parameter set $\{N_{ID}^{(PUSCH)}, N_{ID}^{csh_DMRS}\}$ through higher layer signaling at a specific time, the same value of $N_{ID}^{(PUSCH)}$ may be used for Equation 18, Equation 20, Equation 23 (or Equation 16) and Equation 25, whereas $N_{ID}^{csh_DMRS}$ may be used (or dynamic switching between using of $N_{ID}^{csh_DMRS}$ and using of $N_{ID}^{(PUSCH)}$ may be applied) for the CSH pattern of Equation 26. Dynamic switching may include indication of a parameter to be used from among parameters previously set through higher layer signaling using a specific field of a DCI format.

20 [287] If the UE receives a parameter set $\{N_{ID}^{(PUSCH)}, N_{ID,seq}^{(PUSCH)}\}$ through higher layer signaling, the same value of $N_{ID}^{(PUSCH)}$ may be used for Equation 18, Equation 20, Equation 23 (or Equation 16) and Equation 26, whereas $N_{ID,seq}^{(PUSCH)}$ may be used (or dynamic switching between using of $N_{ID,seq}^{(PUSCH)}$ and using of $N_{ID}^{(PUSCH)}$ may be applied) for the sequence hopping pattern of Equation 25.

25 [288] If the UE receives a parameter set $\{N_{ID}^{(PUSCH)}, N_{ID,seq}^{(PUSCH)}, N_{ID}^{csh_DMRS}\}$ through higher layer signaling at a specific time, the same value of $N_{ID}^{(PUSCH)}$ may be used for Equation 18, Equation 20 and Equation 23 (or Equation 16), $N_{ID,seq}^{(PUSCH)}$ may be used (or dynamic switching between using of $N_{ID,seq}^{(PUSCH)}$ and using of $N_{ID}^{(PUSCH)}$ may be applied) for

the sequence hopping pattern of Equation 25, and $N_{ID}^{csh_DMRS}$ may be used (or dynamic switching between using of $N_{ID}^{csh_DMRS}$ and using of $N_{ID}^{(PUSCH)}$ may be applied) for the CSH pattern of Equation 26.

[289] While operations capable of efficiently supporting CoMP operation using an uplink DMRS have been described above, the scope of the present invention is not limited thereto and the principle of the present invention can be equally applied to other uplink RS transmission/reception schemes.

[290] FIG. 13 is a flowchart illustrating a method for transmitting an uplink DMRS according to an embodiment of the present invention.

[291] The UE can receive a VCI (e.g. n_{ID}^{RS}) from the eNB through higher layer signaling (e.g. RRC signaling) in step S1310. Here, the first VCI (e.g. n_{ID}^{PUCCH}) for the PUCCH DMRS and the second VCI (e.g. n_{ID}^{PUSCH}) for the PUSCH DMRS can be signaled/set as separate parameters (i.e. independent parameters). Furthermore, separate VCIs subdivided for respective operations (particularly, an operation of applying PUSCH DMRS CSH) of generating a base sequence may be signaled/set.

[292] The UE may generate an RS sequence (e.g. a PUCCH DMRS sequence and/or a PUSCH DMRS sequence) in step S1320. The embodiments of the present invention may be applied to DMRS sequence generation. For example, when the VCI is set by a higher layer, a group hopping pattern, a sequence shift pattern, sequence hopping and/or CS hopping can be determined according to the embodiments of the present invention, and the DMRS sequence can be generated according to the determined group hopping pattern, sequence shift pattern, sequence hopping and/or CS hopping. If the VCI is not set by the higher layer, the PUCCH DMRS sequence and/or the PUSCH DMRS sequence can be generated using a PCI as in a conventional wireless communication system. The above-described embodiments of the present invention may be independently applied or two or more embodiments may be simultaneously applied, and redundant descriptions are avoided for clarity.

[293] The UE may map the generated DMRS sequence to an uplink resource and transmit the DMRS sequence to the eNB in step S1330. The positions of REs mapped to the PUSCH DMRS sequence and the positions of REs mapped to the PUCCH DMRS sequence are as described with reference to FIGS. 5 to 10.

[294] When the eNB receives an uplink RS transmitted from the UE, the eNB can detect the uplink RS on the assumption that the UE generates the uplink RS according to the RS sequence generation scheme proposed by the present invention.

[295] FIG. 14 illustrates a configuration of a UE device according to an embodiment of the present invention.

[296] Referring to FIG. 14, a UE device 10 according to an embodiment of the present invention may include a transmitter 11, a receiver 12, a processor 13, a memory 14 and a plurality of antennas 15. The plurality of antennas 15 means that the UE device supports MIMO transmission and reception. The transmitter 11 can transmit signals, data and information to an external device (e.g. eNB). The receiver 12 can receive signals, data and information from an external device (e.g. eNB). The processor 13 can control the overall operation of the UE device 10.

[297] The UE device 10 according to an embodiment of the present invention can be configured to transmit an uplink signal.

[298] The processor 13 of the UE device 10 can receive a VCI (e.g. n_{ID}^{RS}) using the receiver 12 from an eNB through higher layer signaling (e.g. RRC signaling). Here, a VCI (e.g. n_{ID}^{PUCCH}) for a PUCCH DMRS and a VCI (e.g. n_{ID}^{PUSCH}) for a PUSCH DMRS may be independently signaled/set.

[299] The processor 13 of the UE device 10 can be configured to generate an RS sequence (e.g. a PUCCH DMRS sequence and/or a PUSCH DMRS sequence). The embodiments of the present invention may be applied to DMRS sequence generation. For example, when the VCI is set by a higher layer, the processor 13 can determine a group hopping pattern, a sequence shift pattern, sequence hopping and/or CS hopping according to the embodiments of the present invention and generate the DMRS sequence according to the determined group hopping pattern, sequence shift pattern, sequence hopping and/or CS hopping. Alternatively, a group hopping pattern, a sequence shift pattern, sequence hopping and/or CS hopping, which can be generated for each VCI, can be previously generated as a table and appropriate values can be detected from the table according to a set VCI. If the VCI is not set by the higher layer, the PUCCH DMRS sequence and/or the PUSCH DMRS sequence may be generated using a PCI as in a conventional wireless communication system.

[300] The processor 13 of the UE device 10 can map the generated DMRS sequence to an uplink resource and transmit the DMRS sequence to the eNB using the transmitter 12.

The positions of REs mapped to the PUSCH DMRS sequence and the positions of REs mapped to the PUCCH DMRS sequence are as described with reference to FIGS. 5 to 10.

[301] In addition, the processor 13 of the UE device 10 processes information received by the UE device 10, information to be transmitted to an external device, etc. The memory 14 can store the processed information for a predetermined time and can be replaced by a component such as a buffer (not shown).

[302] The UE device 10 may be implemented such that the above-described embodiments of the present invention can be independently applied or two or more embodiments can be simultaneously applied, and redundant descriptions are avoided for clarity.

[303] An eNB device according to an embodiment of the present invention can include a transmitter, a receiver, a processor, a memory and antennas. When the processor of the eNB device receives an uplink RS transmitted from the UE device 10, the processor of the eNB device can be configured to detect the uplink RS on the assumption that the UE device 10 generates the uplink RS according to the RS sequence generation scheme proposed by the present invention.

[304] While an eNB is exemplified as a downlink transmission entity or an uplink reception entity and a UE is exemplified as a downlink reception entity or an uplink transmission entity in the embodiments of the present invention, the scope of the present invention is not limited thereto. For example, description of the eNB can be equally applied to a case in which a cell, an antenna port, an antenna port group, an RRH, a transmission point, a reception point, an access point or a relay node serves as an entity of downlink transmission to a UE or an entity of uplink reception from the UE. Furthermore, the principle of the present invention described through the various embodiment of the present invention can be equally applied to a case in which a relay node serves as an entity of downlink transmission to a UE or an entity of uplink reception from the UE or a case in which a relay node serves as an entity of uplink transmission to an eNB or an entity of downlink reception from the eNB.

[305] The embodiments of the present invention may be implemented by various means, for example, hardware, firmware, software, or combinations thereof.

[306] When the embodiments of the present invention are implemented using hardware, the embodiments may be implemented using at least one of Application Specific Integrated Circuits (ASICs), Digital Signal Processors (DSPs), Digital Signal Processing Devices (DSPDs), Programmable Logic Devices (PLDs), Field Programmable Gate Arrays

(FPGAs), processors, controllers, microcontrollers, microprocessors, etc.

[307] In a firmware or software configuration, the embodiments of the present invention may be implemented in the form of a module, a procedure, a function, etc. For example, software code may be stored in a memory unit and executed by a processor. The
5 memory unit is located at the interior or exterior of the processor and may transmit and receive data to and from the processor via various known means.

[308] Those skilled in the art will appreciate that the present invention may be carried out in other specific ways than those set forth herein without departing from the spirit and essential characteristics of the present invention. The above embodiments are
10 therefore to be construed in all aspects as illustrative and not restrictive. The scope of the invention should be determined by the appended claims and their legal equivalents, not by the above description, and all changes coming within the meaning and equivalency range of the appended claims are intended to be embraced therein.

[309] It is obvious to those skilled in the art that claims that are not explicitly cited in
15 each other in the appended claims may be presented in combination as an exemplary embodiment of the present invention or included as a new claim by subsequent amendment after the application is filed.

【Industrial Applicability】

[310] The above-described embodiments of the present invention can be applied to
20 various mobile communication systems.

【CLAIMS】**【Claim 1】**

A method for transmitting an uplink signal at a user equipment (UE) in a wireless communication system, the method comprising:

5 when a parameter $N_{ID}^{csh_DMRS}$ for a reference signal for demodulation of a physical uplink shared channel (PUSCH) is provided, generating a sequence of the reference signal on the basis of $N_{ID}^{csh_DMRS}$; and

transmitting the generated reference signal to an eNB,

10 wherein, when $N_{ID}^{csh_DMRS}$ is provided, a pseudo-random sequence generator used to determine cyclic shift hopping of the reference signal is initialized according to

$$c_{init} = \left\lfloor \frac{N_{ID}^{csh_DMRS}}{30} \right\rfloor \cdot 2^5 + (N_{ID}^{csh_DMRS} \bmod 30) \text{ at the start of each radio frame,}$$

wherein c_{init} is an initial value of a pseudo-random sequence and mod denotes a modulo operation.

15 【Claim 2】

The method according to claim 1, wherein a virtual cell ID n_{ID}^{PUSCH} is provided as an additional parameter for the UE in addition to $N_{ID}^{csh_DMRS}$.

【Claim 3】

20 The method according to claim 2, wherein $N_{ID}^{csh_DMRS}$ is used for cyclic shift hopping with respect to the reference signal and n_{ID}^{PUSCH} is used for one or more of a group hopping pattern, a sequence shift pattern and a sequence hopping pattern with respect to the reference signal.

【Claim 4】

25 The method according to claim 2, wherein, when n_{ID}^{PUSCH} is provided and sequence group hopping for the reference signal is enabled, a pseudo-random sequence

generator used to determine a group hopping pattern is initialized according to

$$c_{\text{init}} = \left\lfloor \frac{n_{\text{ID}}^{\text{PUSCH}}}{30} \right\rfloor.$$

【Claim 5】

5 The method according to claim 2, wherein, when $n_{\text{ID}}^{\text{PUSCH}}$ is provided, a sequence shift pattern $f_{\text{ss}}^{\text{PUSCH}}$ of the reference signal is determined according to $f_{\text{ss}}^{\text{PUSCH}} = n_{\text{ID}}^{\text{PUSCH}} \bmod 30$.

【Claim 6】

10 The method according to claim 5, wherein, when $n_{\text{ID}}^{\text{PUSCH}}$ is provided, sequence group hopping for the reference signal is disabled and sequence hopping is enabled, a pseudo-random sequence generator used to determine a base sequence number v is initialized according to $c_{\text{init}} = \left\lfloor \frac{n_{\text{ID}}^{\text{PUSCH}}}{30} \right\rfloor \cdot 2^5 + f_{\text{ss}}^{\text{PUSCH}}$ at the start of each radio frame.

15 **【Claim 7】**

The method according to claim 2, wherein, when $n_{\text{ID}}^{\text{PUSCH}}$ is not provided, c_{init} is determined according to $c_{\text{init}} = \left\lfloor \frac{N_{\text{ID}}^{\text{cell}}}{30} \right\rfloor$,

wherein $N_{\text{ID}}^{\text{cell}}$ is a physical layer cell ID.

20 **【Claim 8】**

The method according to claim 2, wherein when $n_{\text{ID}}^{\text{PUSCH}}$ is not provided, the sequence shift pattern $f_{\text{ss}}^{\text{PUSCH}}$ of the reference signal is determined according to $f_{\text{ss}}^{\text{PUSCH}} = (N_{\text{ID}}^{\text{cell}} + \Delta_{\text{ss}}) \bmod 30$,

wherein Δ_{ss} is set by a higher layer and $\Delta_{\text{ss}} \in \{0,1,\dots,29\}$.

【Claim 9】

The method according to claim 8, wherein, when n_{ID}^{PUSCH} is not provided, sequence group hopping for the reference signal is disabled and sequence hopping is enabled, a pseudo-random sequence generator used to determine a base sequence number v

is initialized according to $c_{init} = \left\lfloor \frac{N_{ID}^{cell}}{30} \right\rfloor \cdot 2^5 + f_{ss}^{PUSCH}$ at the start of each radio frame.

【Claim 10】

The method according to claim 2, wherein $N_{ID}^{csh_DMRS}$ and n_{ID}^{PUSCH} are set by a higher layer.

【Claim 11】

The method according to claim 2, wherein n_{ID}^{PUSCH} is set one of 0 to 509.

【Claim 12】

The method according to claim 1, wherein, when $N_{ID}^{csh_DMRS}$ is not provided, a pseudo-random sequence generator used to determine cyclic shift hopping of the reference

signal is initialized according to $c_{init} = \left\lfloor \frac{N_{ID}^{cell}}{30} \right\rfloor \cdot 2^5 + ((N_{ID}^{cell} + \Delta_{ss}) \bmod 30)$ at the

start of each radio frame,

wherein N_{ID}^{cell} is a physical layer cell ID, Δ_{ss} is set by a higher layer and $\Delta_{ss} \in \{0,1,\dots,29\}$.

【Claim 13】

The method according to claim 1, wherein $N_{ID}^{csh_DMRS}$ is set one of 0 to 509.

【Claim 14】

The method according to claim 1, wherein the reference signal is transmitted on an SC-FDMA (Single Carrier Frequency Division Multiple Access) symbol in a slot in which the PUSCH is transmitted.

5 **【Claim 15】**

A UE device for transmitting an uplink signal, comprising:

a receiver;

a transmitter; and

a processor,

10 wherein, when a parameter $N_{ID}^{csh_DMRS}$ for a reference signal for demodulation of a physical uplink shared channel (PUSCH) is provided, the processor is configured to generate a sequence of the reference signal on the basis of $N_{ID}^{csh_DMRS}$ and to transmit the generated reference signal to an eNB,

15 wherein, when $N_{ID}^{csh_DMRS}$ is provided, a pseudo-random sequence generator used to determine cyclic shift hopping of the reference signal is initialized according to

$$c_{init} = \left\lfloor \frac{N_{ID}^{csh_DMRS}}{30} \right\rfloor \cdot 2^5 + (N_{ID}^{csh_DMRS} \bmod 30) \text{ at the start of each radio frame,}$$

wherein c_{init} is an initial value of a pseudo-random sequence and mod denotes a modulo operation.

20

FIG. 1

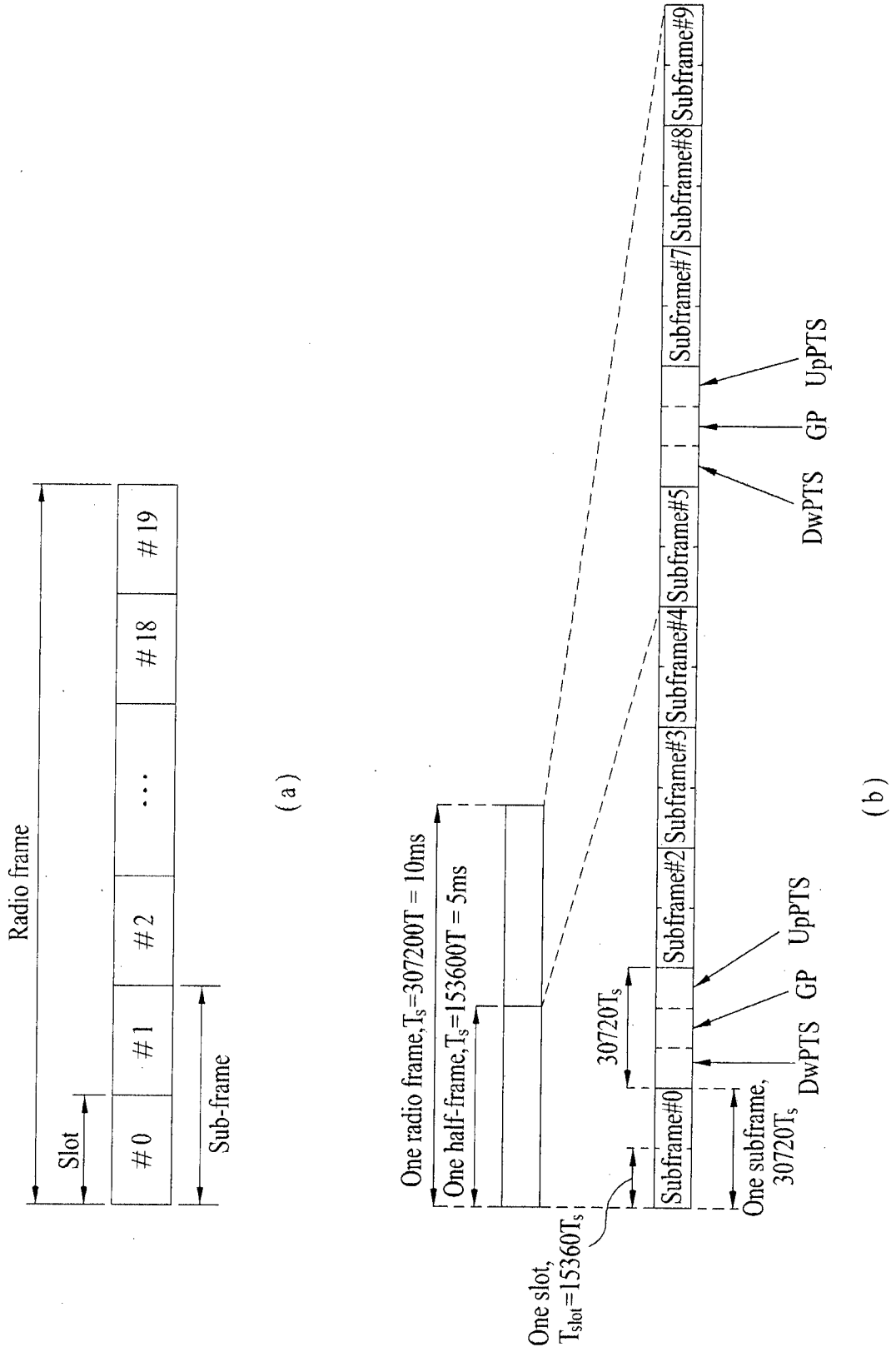

FIG. 2

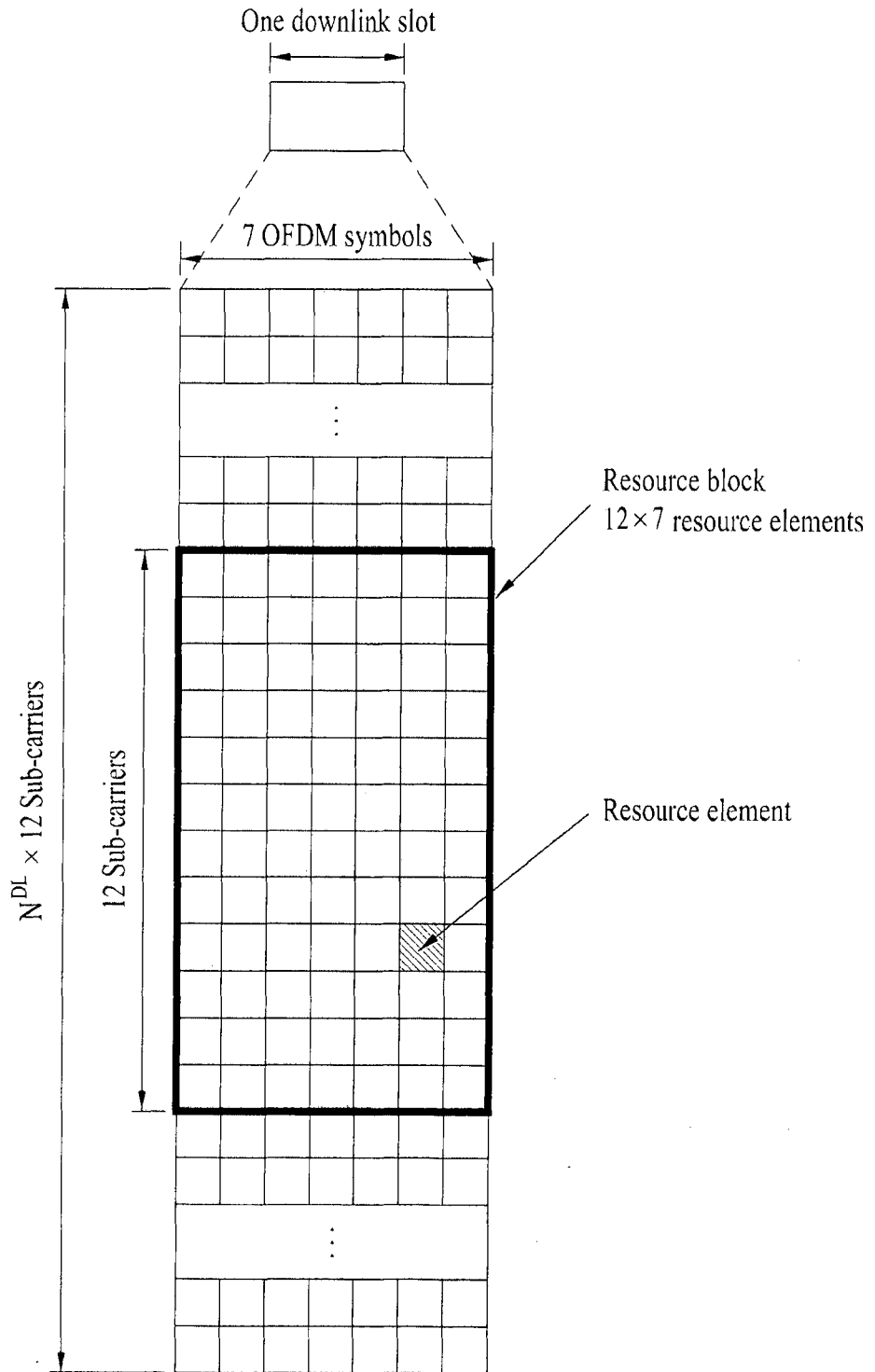

FIG. 3

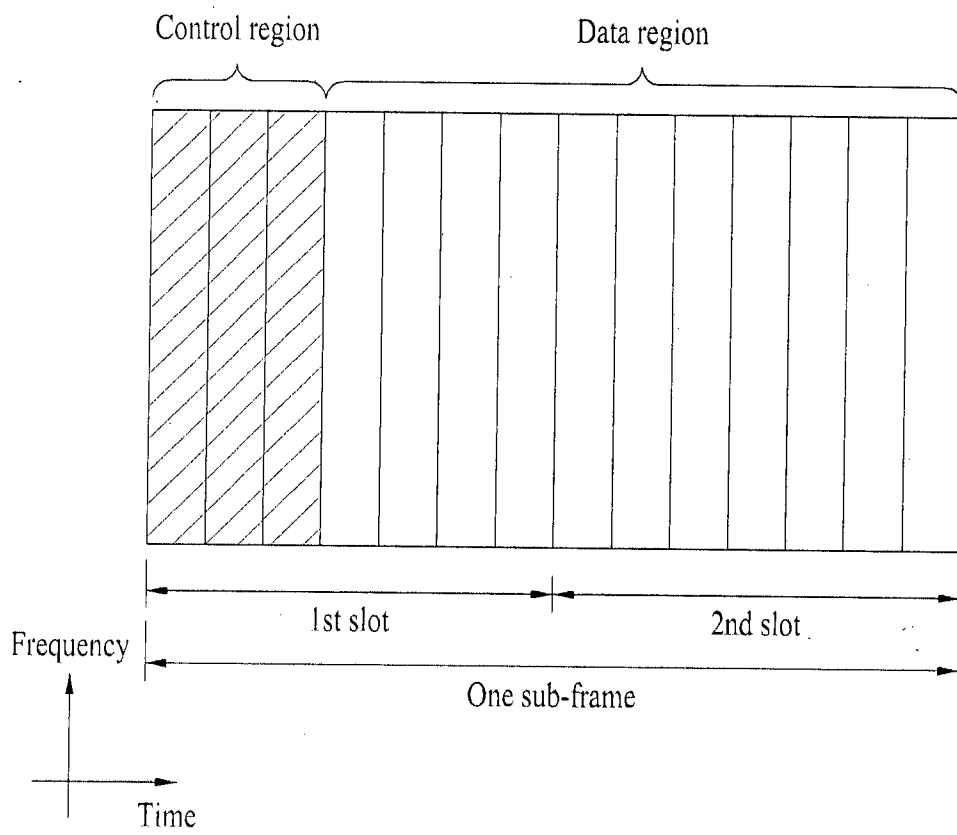

FIG. 4

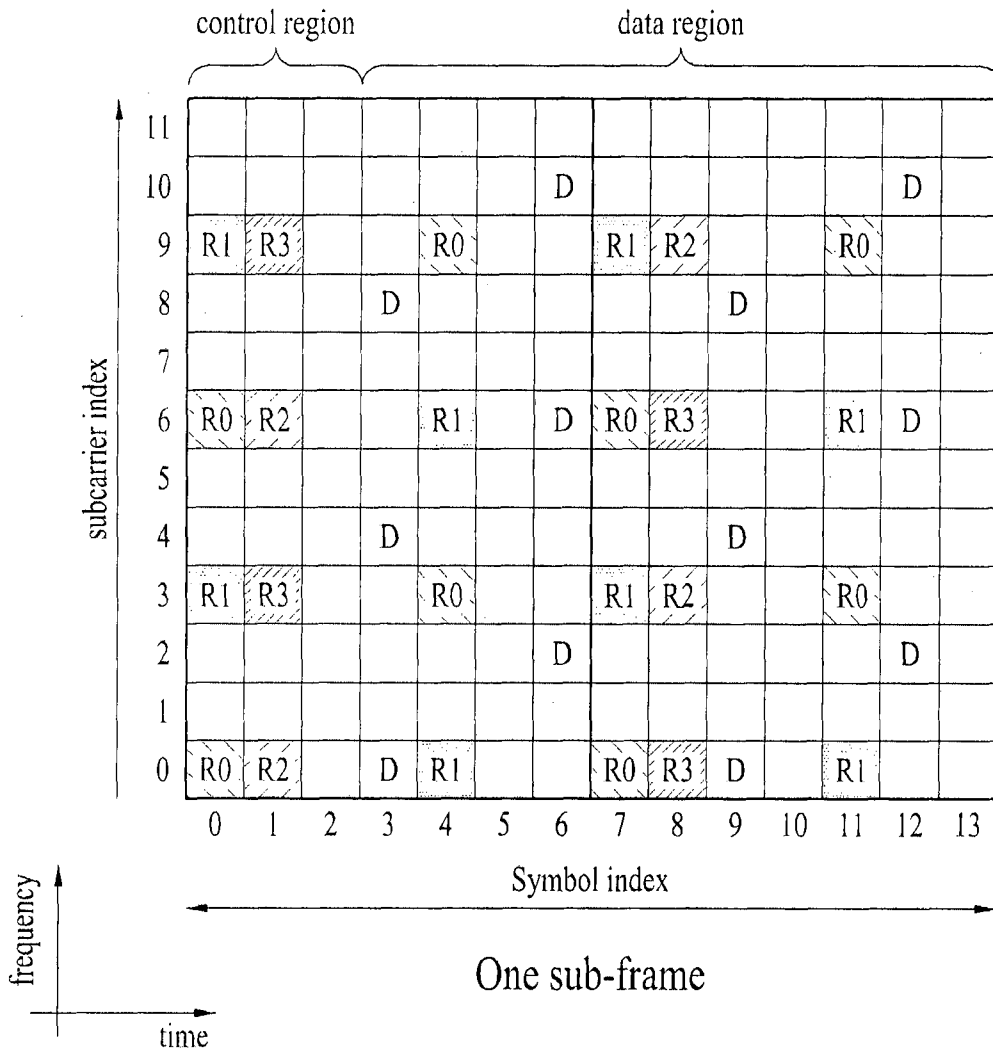

FIG. 5

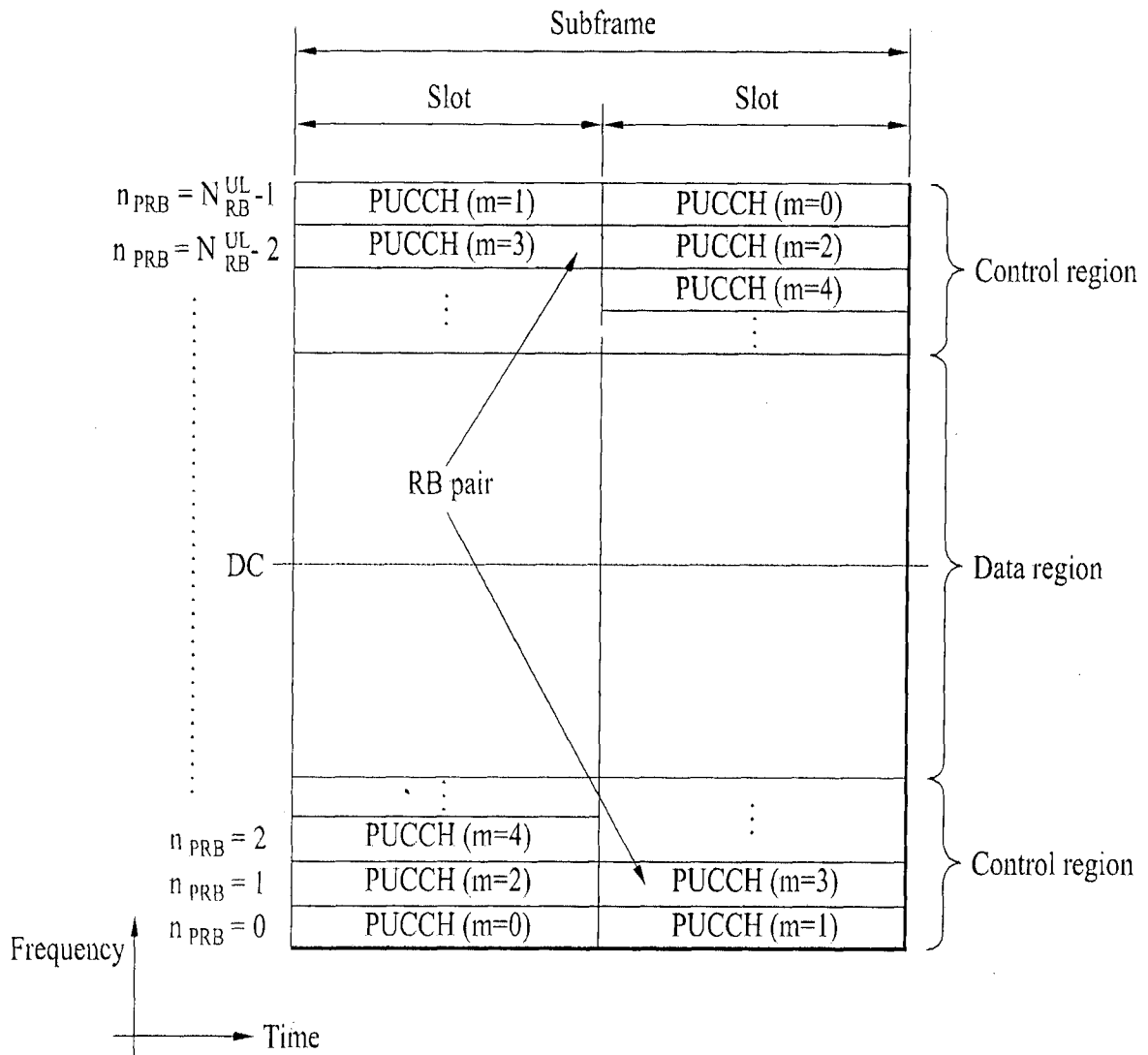
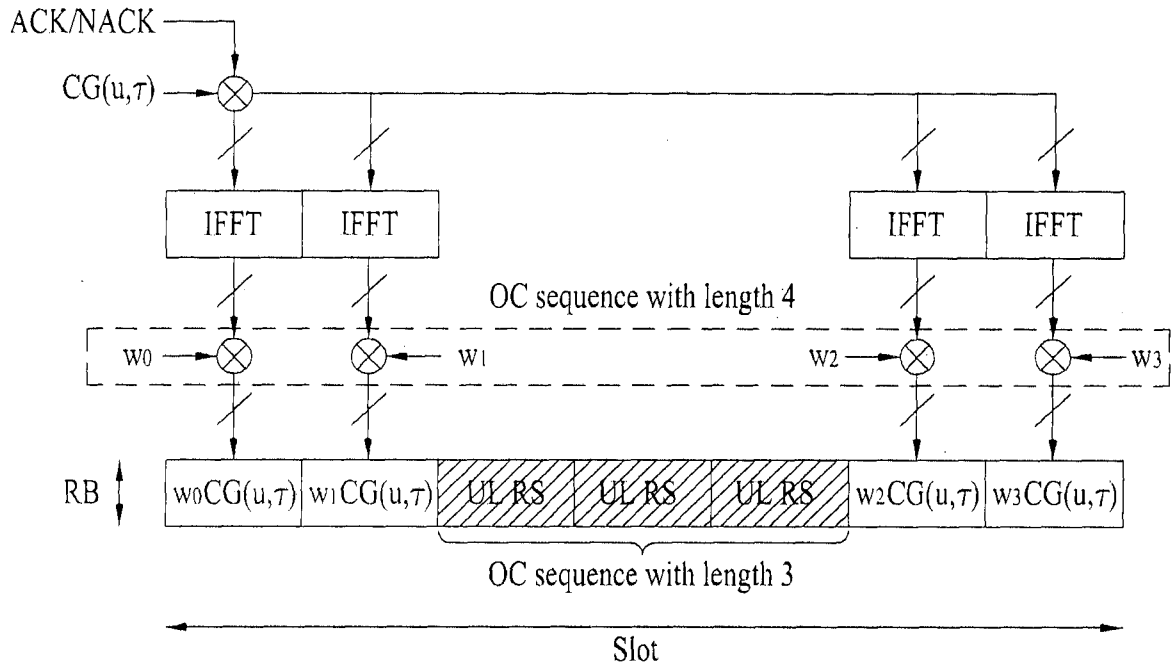
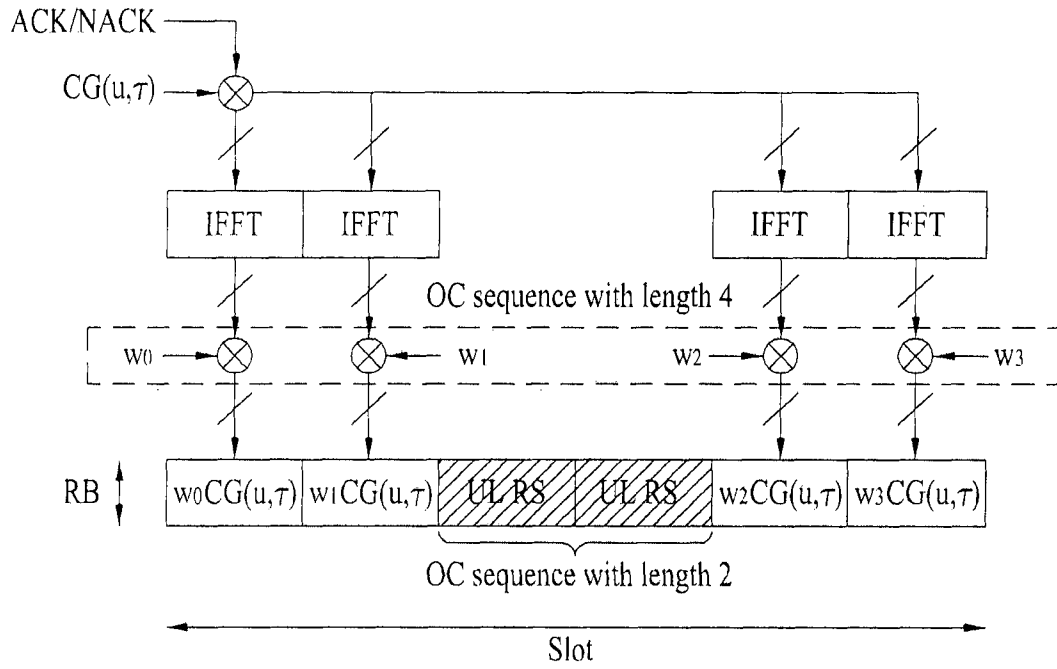

FIG. 6



PUCCH format 1a/1b structure (normal CP)

FIG. 7



PUCCH format 1a/1b structure (extended CP)

FIG. 8

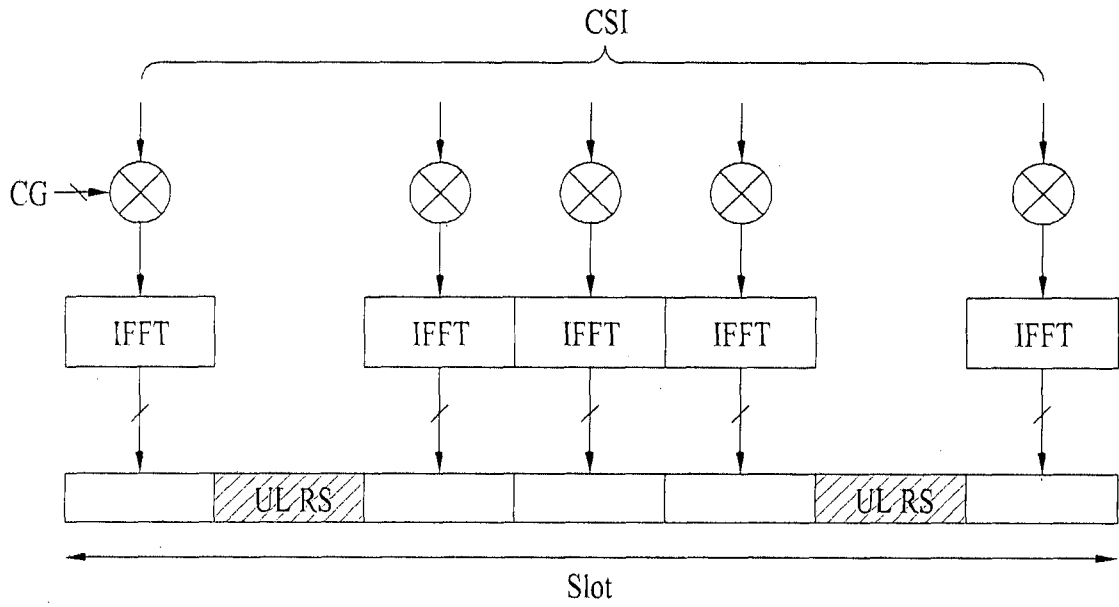

PUCCH format 2/2a/2b structure (normal CP)

FIG. 9

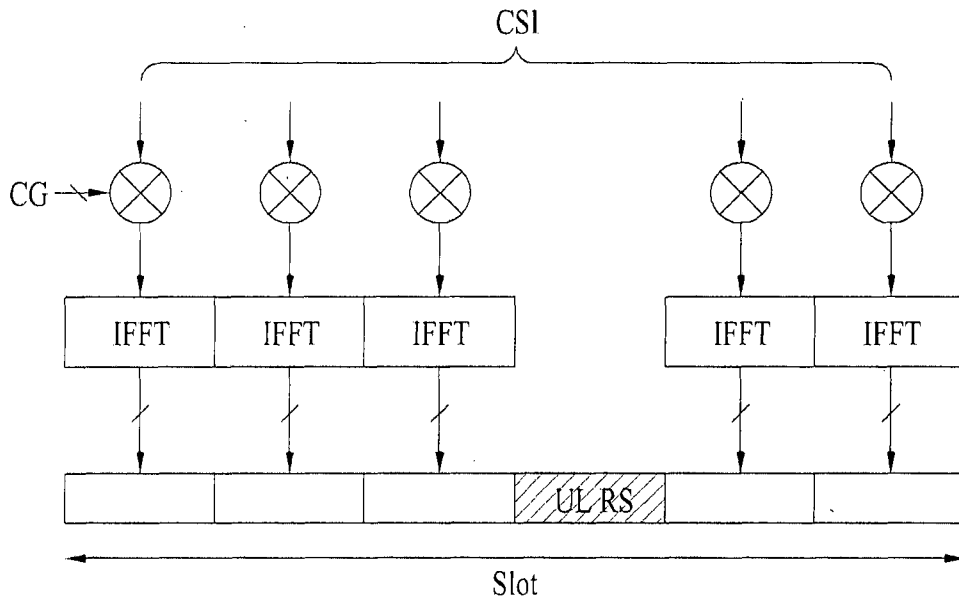

PUCCH format 2/2a/2b structure (extended CP)

FIG. 10

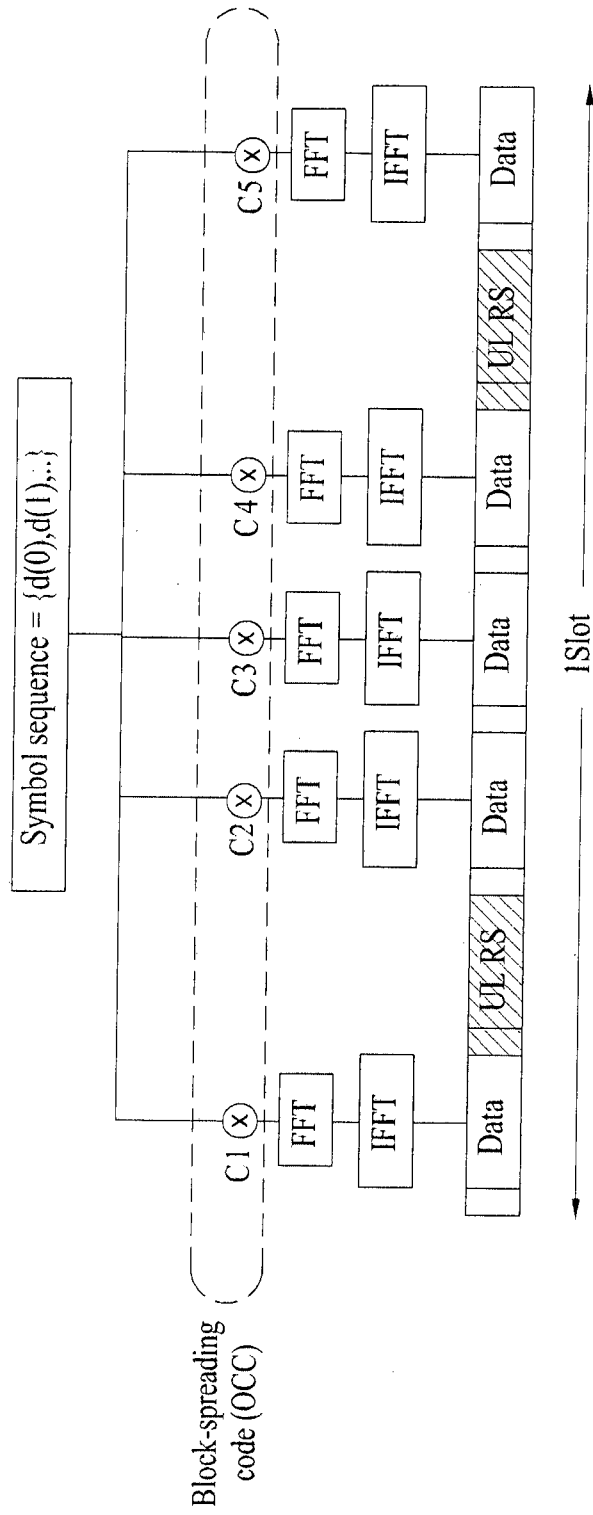

FIG. 11

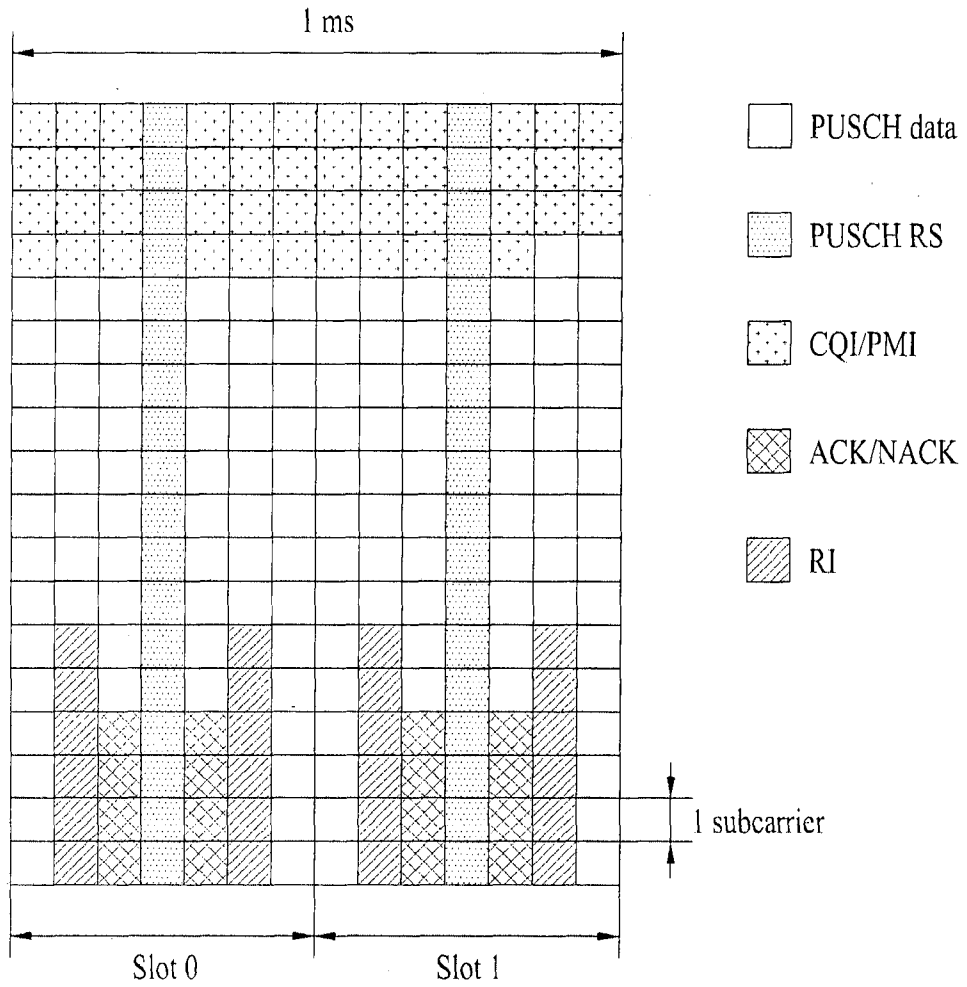

FIG. 12

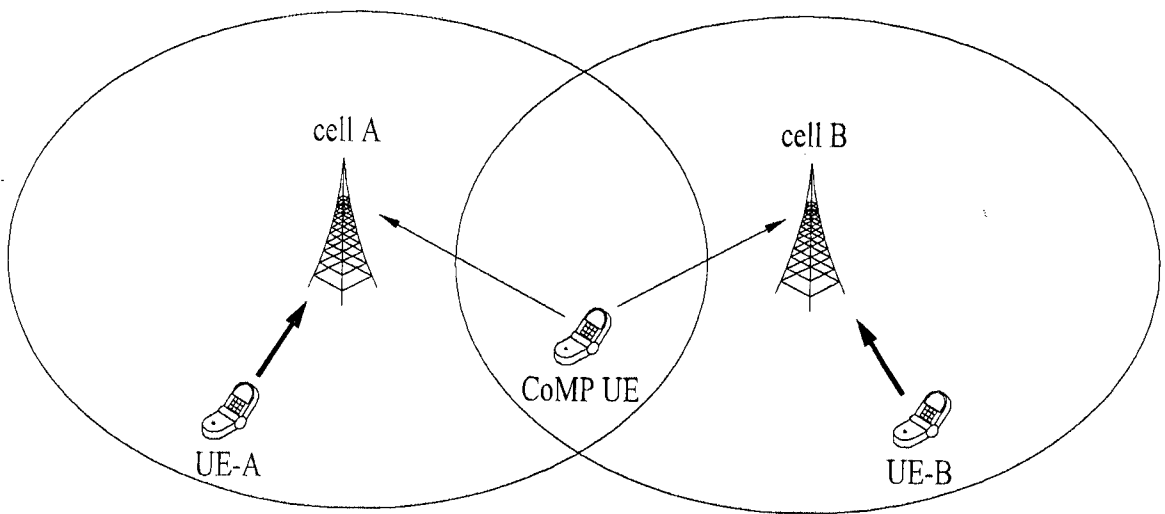

FIG. 13

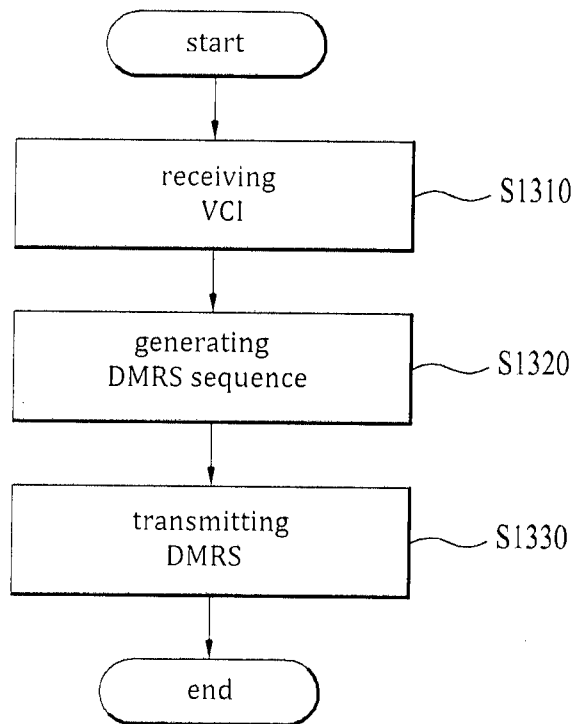
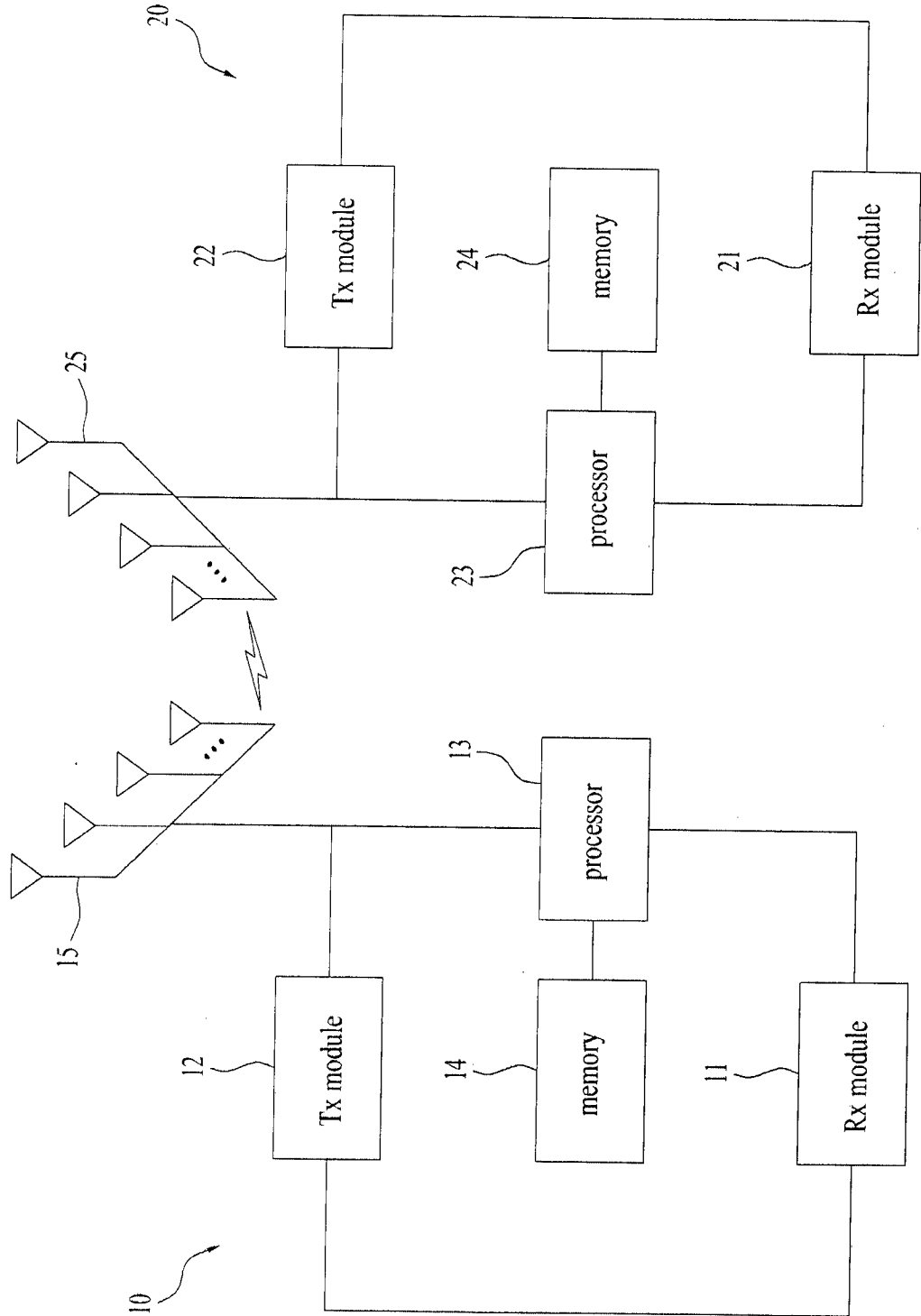

FIG. 14



INTERNATIONAL SEARCH REPORT

International application No.
PCT/KR2013/001323**A. CLASSIFICATION OF SUBJECT MATTER****H04L 27/26(2006.01)i, H04L 1/00(2006.01)j**

According to International Patent Classification (IPC) or to both national classification and IPC

B. FIELDS SEARCHEDMinimum documentation searched (classification system followed by classification symbols)
H04L 27/26; H04L 1/00; H04B 7/26; H04W 88/02; H04B 1/00Documentation searched other than minimum documentation to the extent that such documents are included in the fields searched
Korean utility models and applications for utility models
Japanese utility models and applications for utility modelsElectronic data base consulted during the international search (name of data base and, where practicable, search terms used)
eKOMPASS(KIPO internal) & Keywords: PUSCH, DMRS, cyclic shift hopping, pseudo-random sequence, modulo operation and similar terms.**C. DOCUMENTS CONSIDERED TO BE RELEVANT**

Category*	Citation of document, with indication, where appropriate, of the relevant passages	Relevant to claim No.
A	PANASONIC, `Uplink DMRS sequence in RACH procedure.` R1-111936, 3GPP TSG RAN WG1 Meeting #65, Barcelona, Spain, 9-13 May, 2011 See section 5.5.2.1.1.	1-15
A	KR 10-2009-0112534 A (LG ELECTRONICS INC.) 28 October 2009 See paragraphs [0030]-[0034], [0043]-[0048], [0070]-[0086], and [0150]-[0151]; claims 1 and 10-11; and figure 2.	1-15
A	PANTECH, `UL DM-RS enhancements for Rel-11.` R1-120324, 3GPP TSG RAN WG1 Meeting #68, Dresden, Germany, 06-10 February 2012 See pages 1-4 and 6.	1-15
A	KR 10-2011-0125618 A (LG ELECTRONICS INC.) 21 November 2011 See paragraphs [0070]-[0073], [0105], [0110]-[0115], and [0140]-[0150]; claim 1; and figures 12 and 15.	1-15
A	US 2008-0298433 A1 (ESA TIROLA et al.) 4 December 2008 See paragraphs [0048]-[0055], [0092]-[0098], and [0162]; claim 1; and figures 10 and 17.	1-15

 Further documents are listed in the continuation of Box C. See patent family annex.

* Special categories of cited documents:

"A" document defining the general state of the art which is not considered to be of particular relevance

"E" earlier application or patent but published on or after the international filing date

"L" document which may throw doubts on priority claim(s) or which is cited to establish the publication date of citation or other special reason (as specified)

"O" document referring to an oral disclosure, use, exhibition or other means

"P" document published prior to the international filing date but later than the priority date claimed

"T" later document published after the international filing date or priority date and not in conflict with the application but cited to understand the principle or theory underlying the invention

"X" document of particular relevance; the claimed invention cannot be considered novel or cannot be considered to involve an inventive step when the document is taken alone

"Y" document of particular relevance; the claimed invention cannot be considered to involve an inventive step when the document is combined with one or more other such documents, such combination being obvious to a person skilled in the art

"&" document member of the same patent family

Date of the actual completion of the international search

21 June 2013 (21.06.2013)

Date of mailing of the international search report

24 June 2013 (24.06.2013)

Name and mailing address of the ISA/KR

 Korean Intellectual Property Office
 189 Cheongsu-ro, Seo-gu, Daejeon Metropolitan City,
 302-701, Republic of Korea

Facsimile No. 82-42-472-7140

Authorized officer

NHO, Ji Myong

Telephone No. 82-42-481-8528



INTERNATIONAL SEARCH REPORT

Information on patent family members

International application No.

PCT/KR2013/001323

Patent document cited in search report	Publication date	Patent family member(s)	Publication date
KR 10-2009-0112534 A	28.10.2009	None	
KR 10-2011-0125618 A	21.11.2011	CA 2786700 A1 CN 102696193 A EP 2523378 A2 KR 10-2011-0081106 A WO 2011-084004 A2 WO 2011-142625 A2	14.07.2011 26.09.2012 14.11.2012 13.07.2011 14.07.2011 17.11.2011
US 2008-0298433 A1	04.12.2008	AU 2008-244400 A1 CA 2684364 A1 CN 101926112 A EP 2156587 A1 EP 2166685 A2 EP 2166685 A3 JP 2010-525708 A KR 10-1103605 B1 KR 2009-0131681 A MX 2009-011674 A RU 2009-144134 A US 2012-201275 A1 WO 2008-132073 A1	06.11.2008 06.11.2008 22.12.2010 24.02.2010 24.03.2010 04.07.2012 22.07.2010 09.01.2012 29.12.2009 29.01.2010 10.06.2011 09.08.2012 06.11.2008