



US00RE41873E

(19) **United States**
(12) **Reissued Patent**
Lee et al.

(10) **Patent Number:** **US RE41,873 E**
(45) **Date of Reissued Patent:** ***Oct. 26, 2010**

(54) **MULTIPLE TESTING BARS FOR TESTING LIQUID CRYSTAL DISPLAY AND METHOD THEREOF**

(75) Inventors: **Sang-Kyoung Lee**, KwangJu (KR);
Dong-Gyu Kim, Yongin-si (KR);
Min-Hyung Moon, Cheonan (KR)

(73) Assignee: **Samsung Electronics Co., Ltd.**,
Gyeonggi-do (KR)

(*) Notice: This patent is subject to a terminal disclaimer.

(21) Appl. No.: **11/648,695**

(22) Filed: **Dec. 29, 2006**

Related U.S. Patent Documents

Reissue of:

(64) Patent No.: **6,734,925**
Issued: **May 11, 2004**
Appl. No.: **09/206,317**
Filed: **Dec. 7, 1998**

(30) **Foreign Application Priority Data**

May 12, 1997 (KR) 1997-66154
Nov. 18, 1998 (KR) 1998-49389

(51) **Int. Cl.**
G02F 1/1333 (2006.01)

(52) **U.S. Cl.** **349/40; 324/770**

(58) **Field of Classification Search** **349/40,**
349/54, 55, 192; 324/770
See application file for complete search history.

(56) **References Cited**

U.S. PATENT DOCUMENTS

5,598,283 A 1/1997 Fujii et al.
5,668,032 A 9/1997 Holmberg et al.
6,005,647 A * 12/1999 Lim 349/40
6,013,923 A 1/2000 Huang
6,025,891 A 2/2000 Kim

6,091,464 A * 7/2000 Song 349/38
6,111,620 A * 8/2000 Nishiki et al. 349/54
6,734,925 B1 5/2004 Lee et al.
6,982,569 B2 * 1/2006 Lee et al. 324/770
7,375,375 B2 5/2008 Yamazaki et al.
7,446,556 B2 * 11/2008 Lee et al. 324/770
6,982,768 B2 7/2009 Ohori et al.
2001/0045997 A1 11/2001 Kim

FOREIGN PATENT DOCUMENTS

JP 1-233425 9/1989
JP 2-135490 5/1990
JP 03-094223 4/1991
JP 3-134628 6/1991
JP 04-179926 6/1992
JP 05-005866 1/1993
JP 7-5481 1/1994
JP 6-82817 3/1994
JP 6-82836 3/1994
JP 8-15733 1/1996
JP 08-005691 1/1996
JP 08-328033 12/1996
JP 09-074253 3/1997
JP 9-127552 5/1997
JP 09-185072 7/1997
JP 10-020334 1/1998
JP 10-133214 5/1998
JP 10-186392 7/1998
JP 11-119683 4/1999

OTHER PUBLICATIONS

English Language Abstract, Publication No. JP1233425, Sep. 19, 1989, 1 p.
English Language Abstract, Publication No. JP2135490, May 25, 1990, 1 p.
English Language Abstract, Publication No. JP3134628, Jun. 7, 1991, 1 p.
Patent Abstracts of Japan, Publication No. 06-082817, Mar. 25, 1994, 2 pp.
Patent Abstracts of Japan, Publication No. 06-082836, Mar. 25, 1994, 2 pp.
Patent Abstracts of Japan, Publication No. 07-005481, Jan. 10, 1995, 1 p.
English Language Abstract, Publication No. JP8015733, Jan. 19, 1996, 1 p.

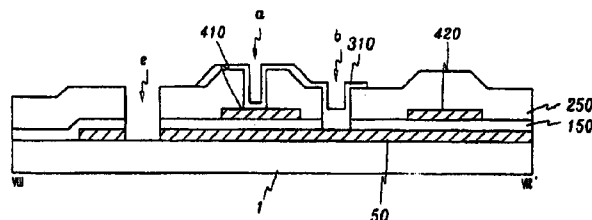
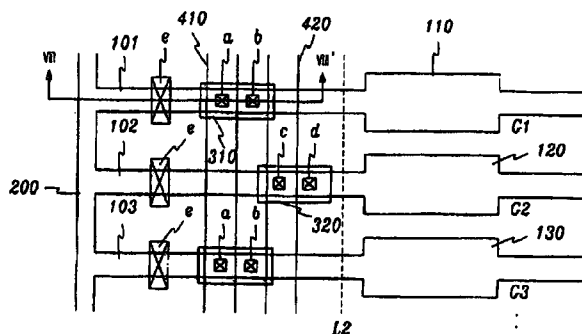

English Language Abstract, Publication No. JP9127552, May 16, 1997, 1 p.

* cited by examiner

Primary Examiner—Andrew Schechter
(74) *Attorney, Agent, or Firm*—Innovation Counsel LLP

(57)

ABSTRACT

A plurality of gate lines are formed on an insulating substrate in the horizontal direction, a gate shorting bar connected to the data lines is formed in the vertical direction and

a gate insulating film is formed thereon. A plurality of data lines intersecting the gate lines are formed on the gate insulating film in the vertical direction, and a data shorting bar connected to the data lines is formed outside the display region. A first shorting bar is formed on the gate insulating film, located between the gate lines and the gate shorting bar, and connected to the odd gate lines. A second secondary shorting bar is formed parallel to the first shorting bar and connected to the even gate lines.

25 Claims, 21 Drawing Sheets

FIG.1(Prior Art)

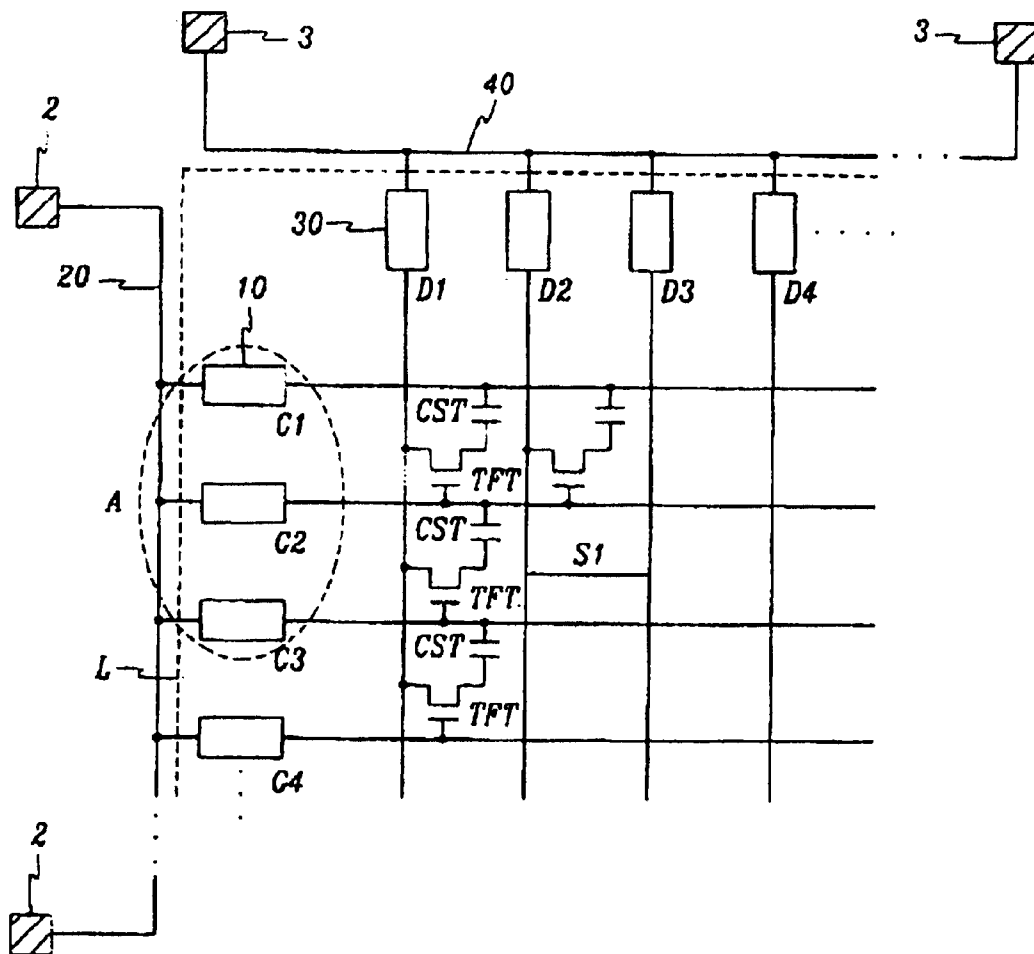

FIG.2(Prior Art)

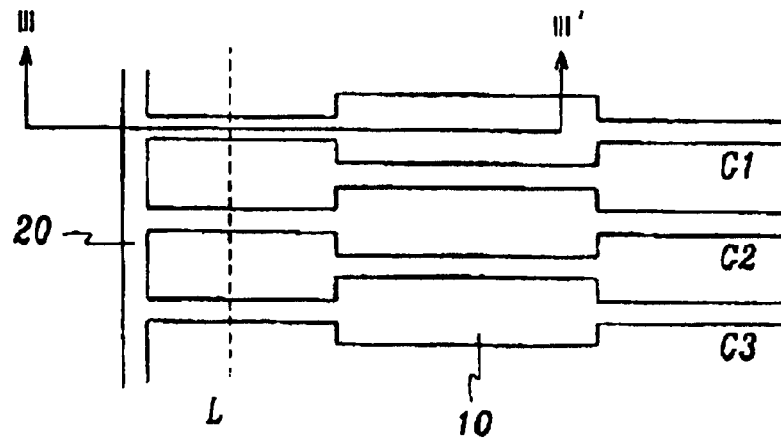

FIG.3(Prior Art)

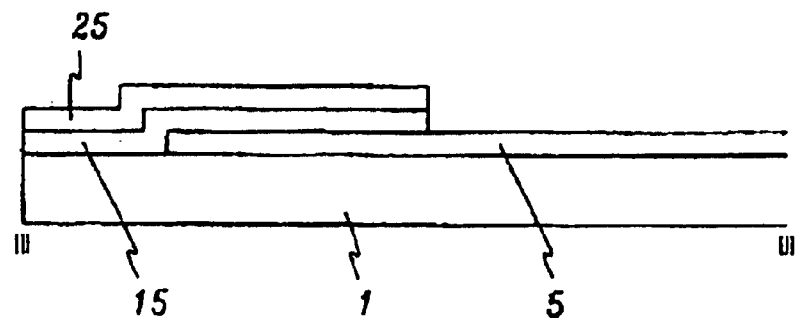

FIG.4(Prior Art)

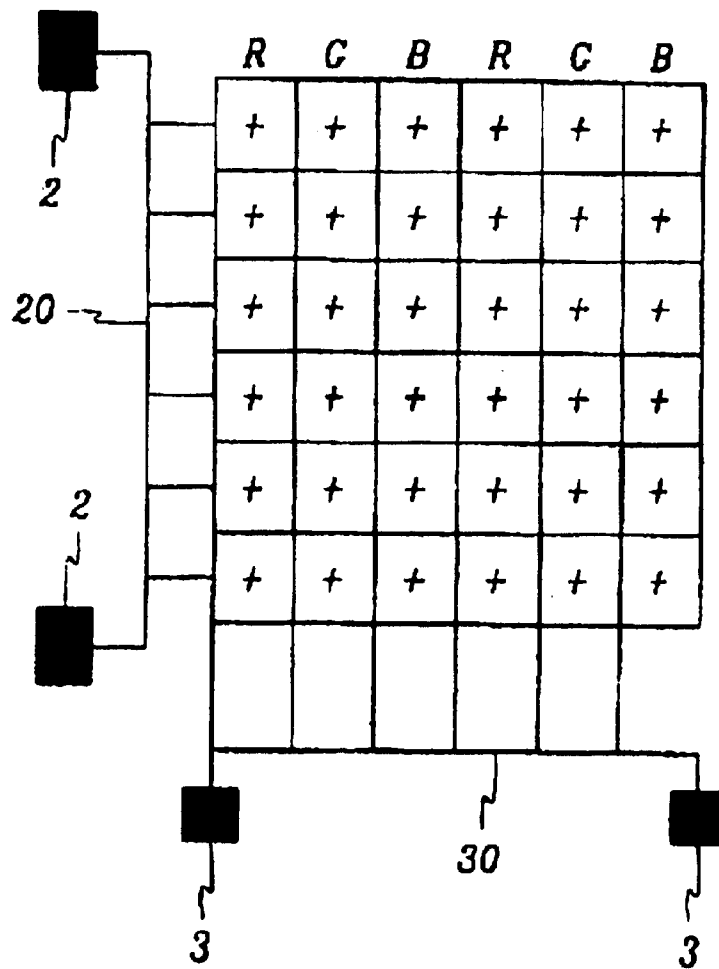

FIG. 5

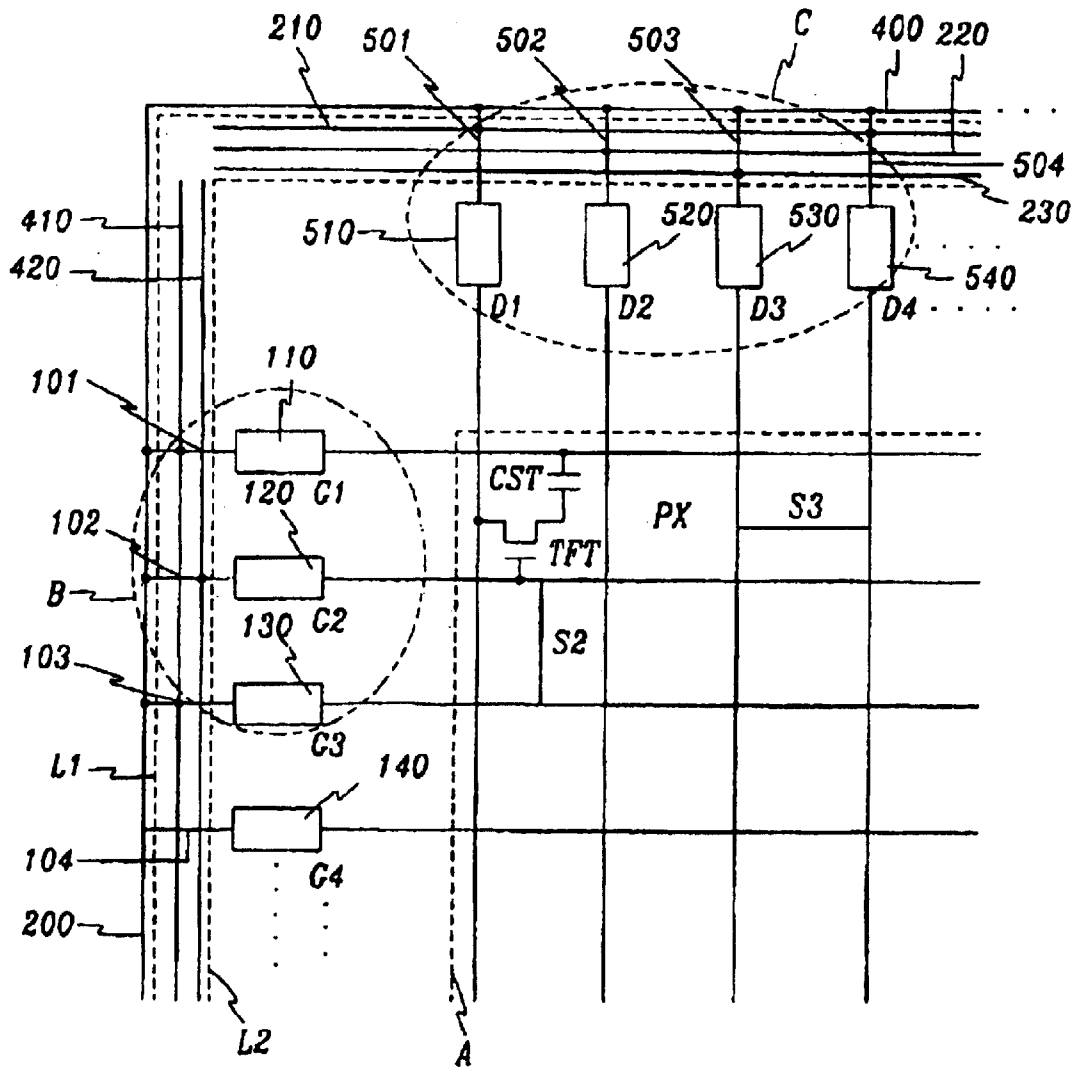

FIG. 6

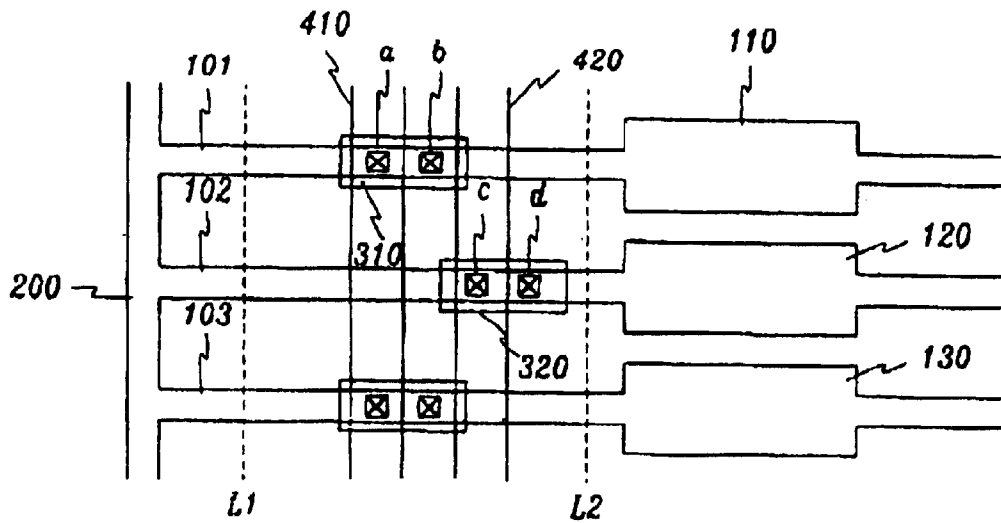

FIG. 7

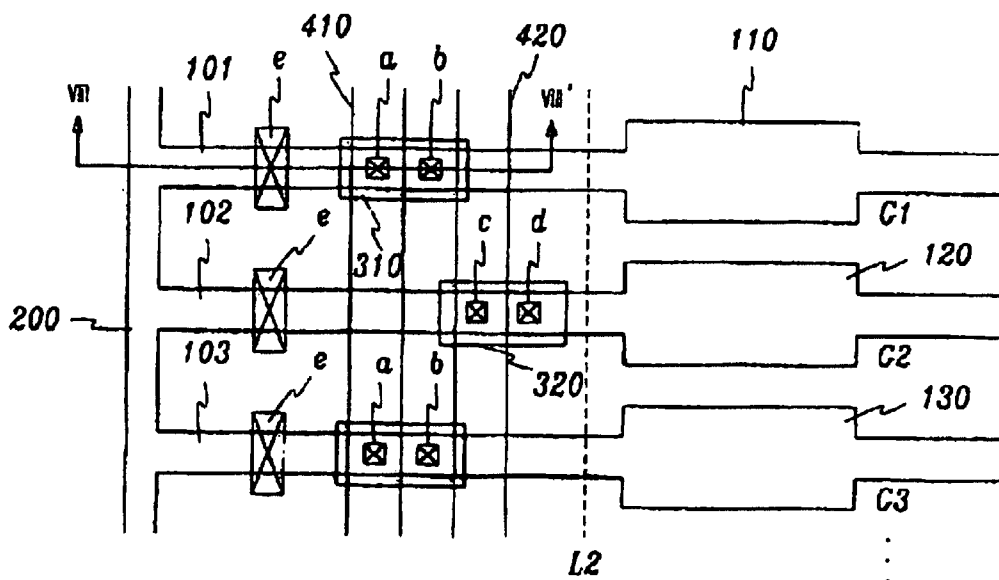

FIG. 8

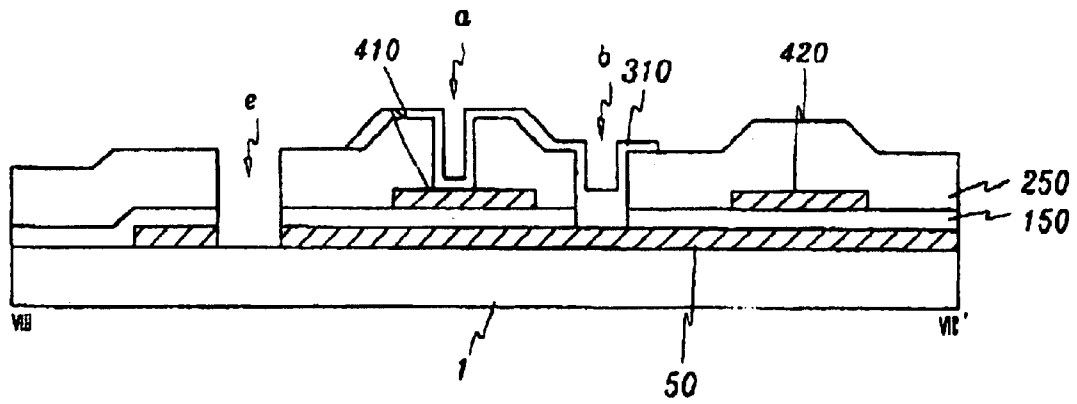

FIG. 10

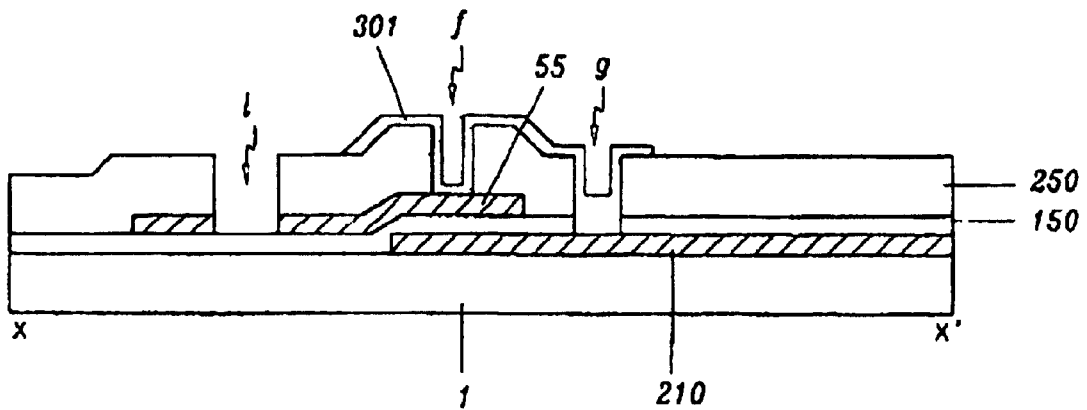

FIG.11A

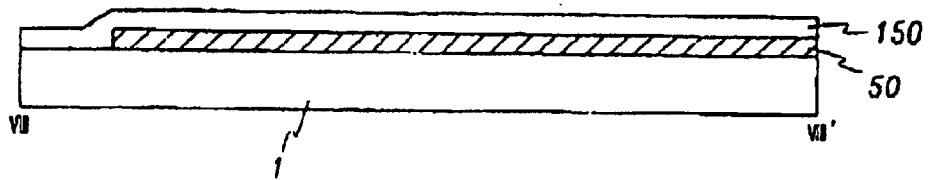

FIG.11B

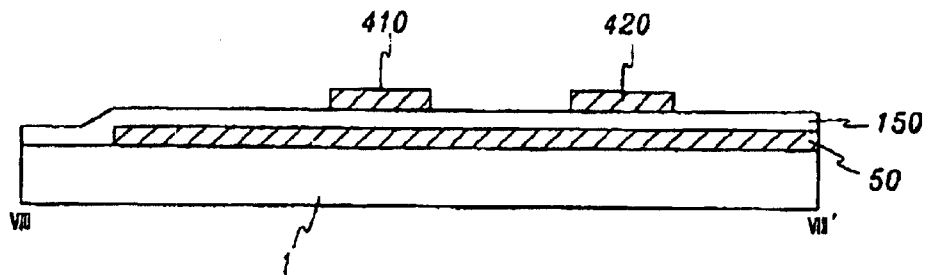

FIG.11C

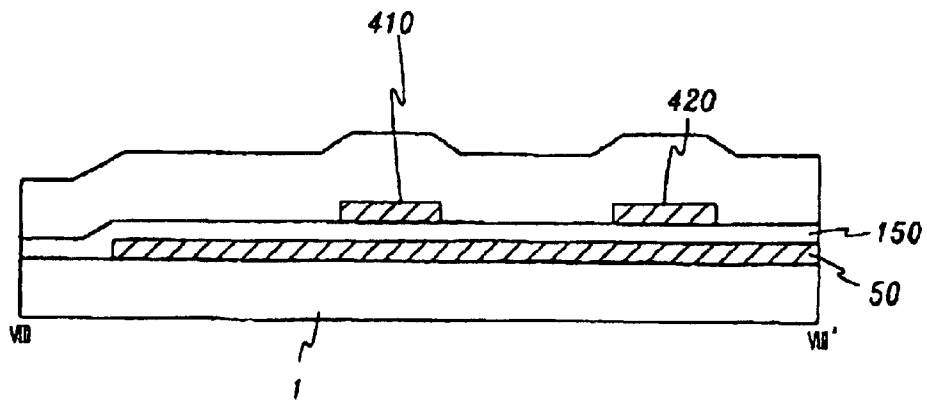

FIG. 11D

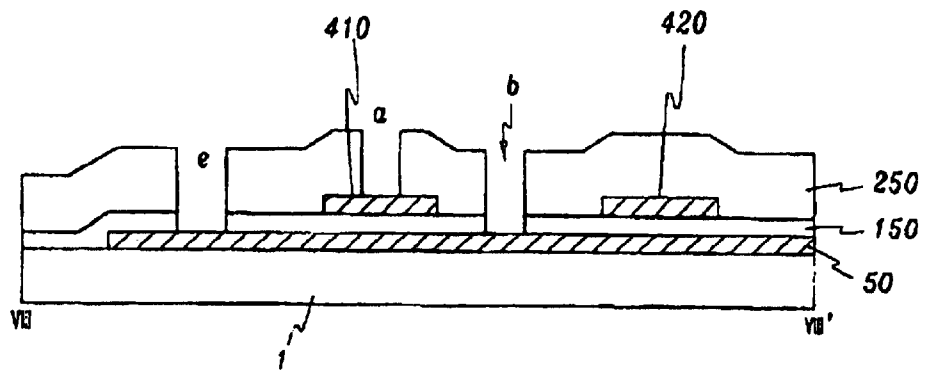

FIG. 11E

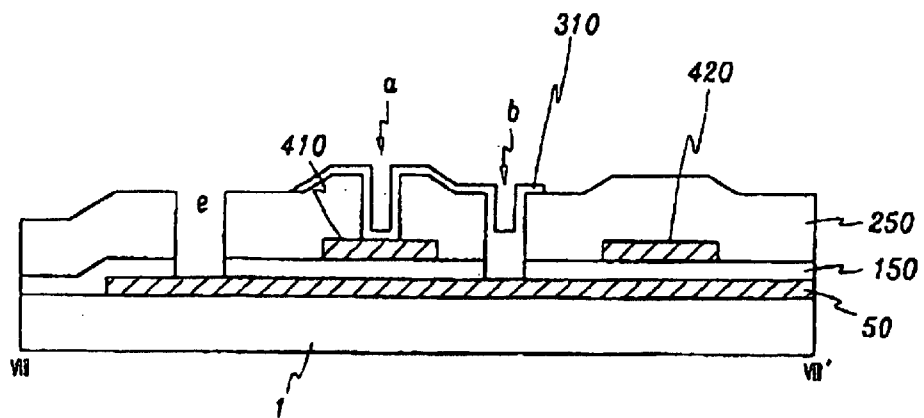

FIG. 11F

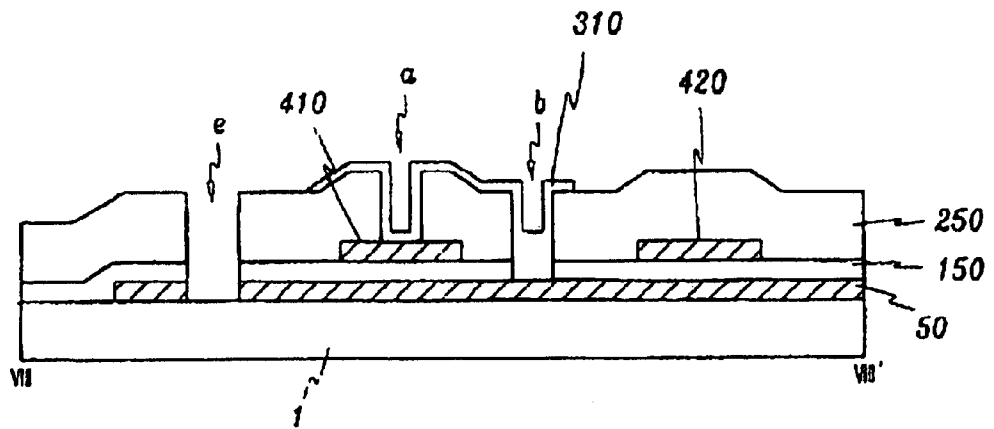

FIG.12A

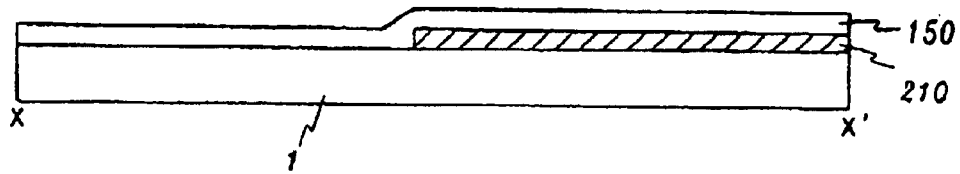

FIG.12B

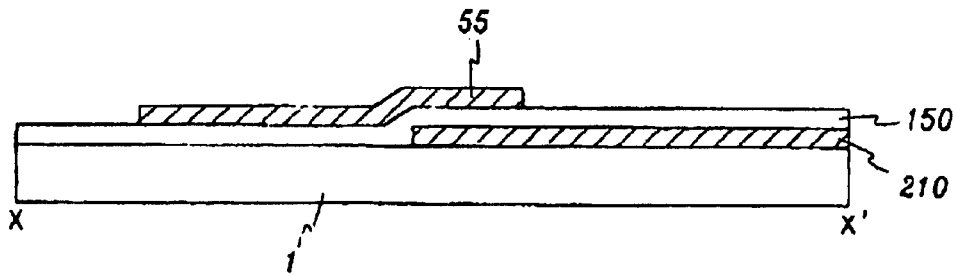

FIG.12C

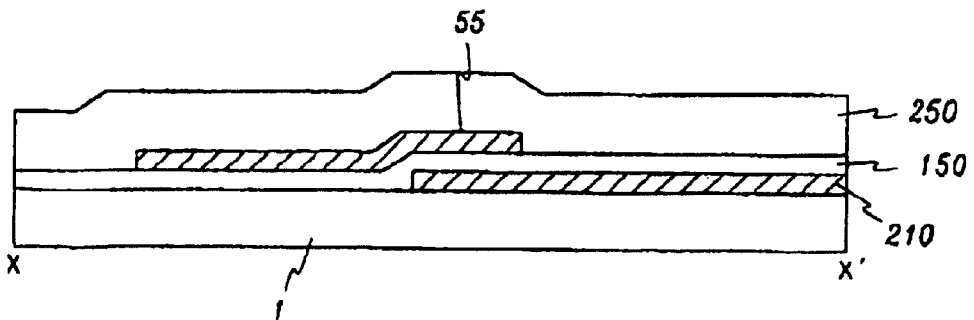

FIG. 12D

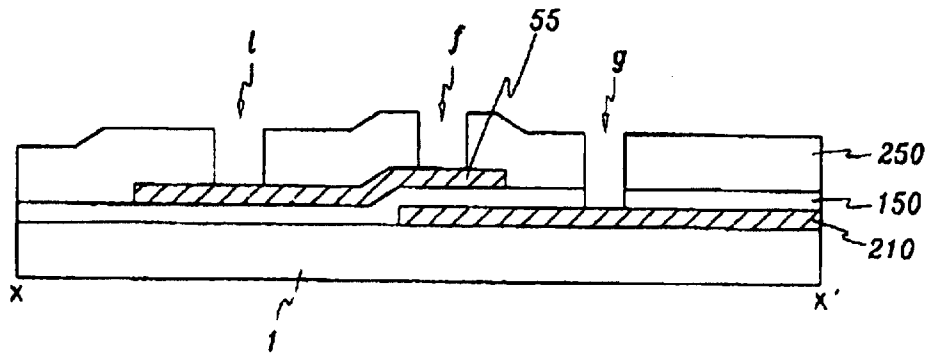

FIG. 12E

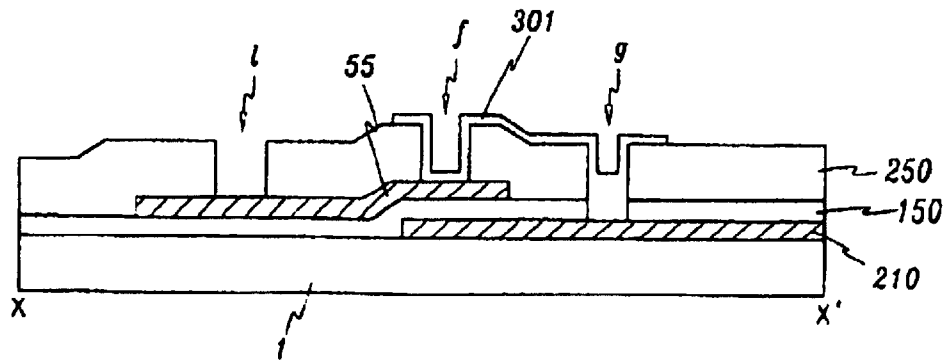

FIG. 12F

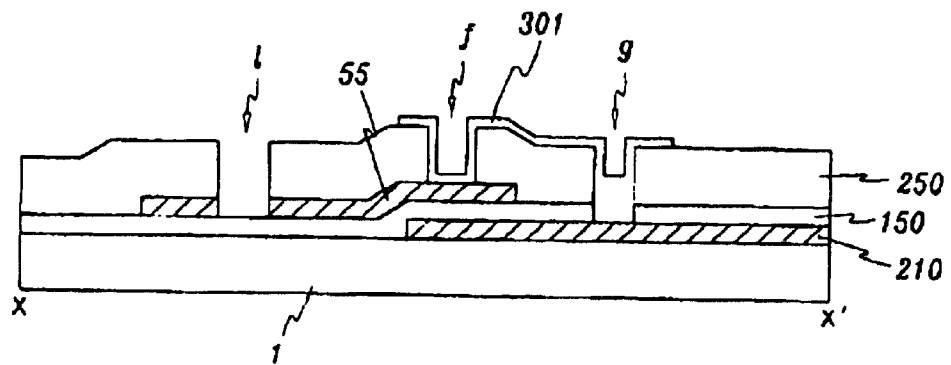

FIG. 13

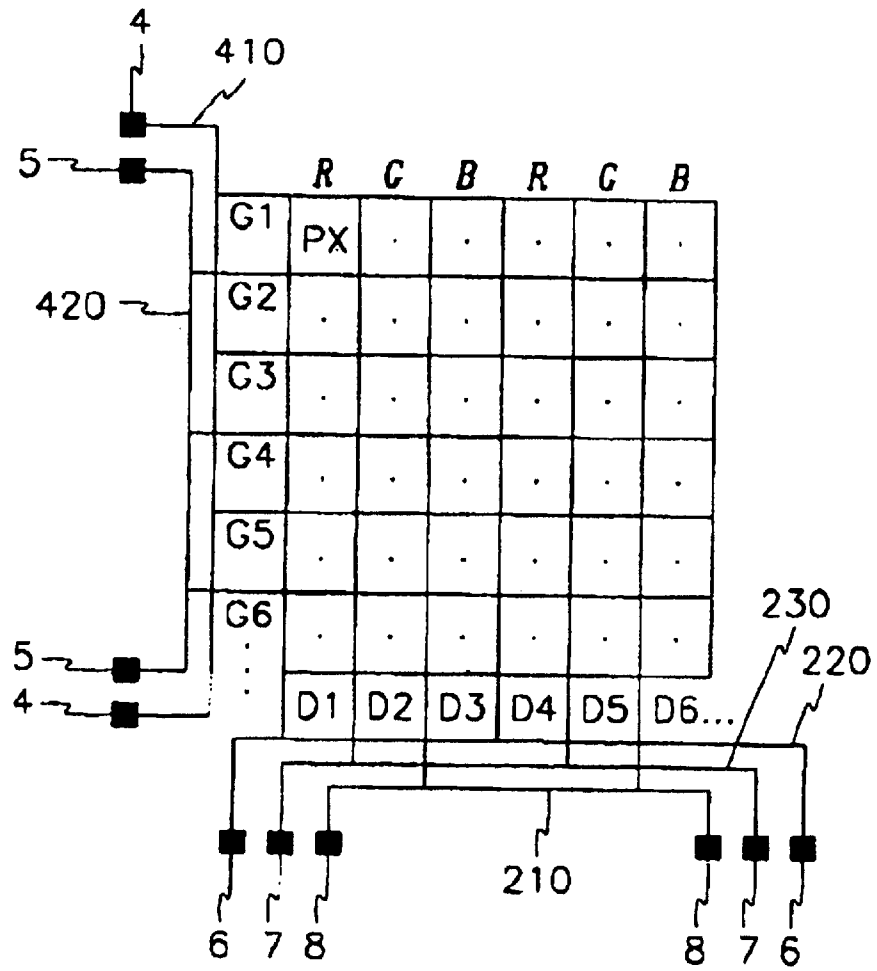

FIG. 14

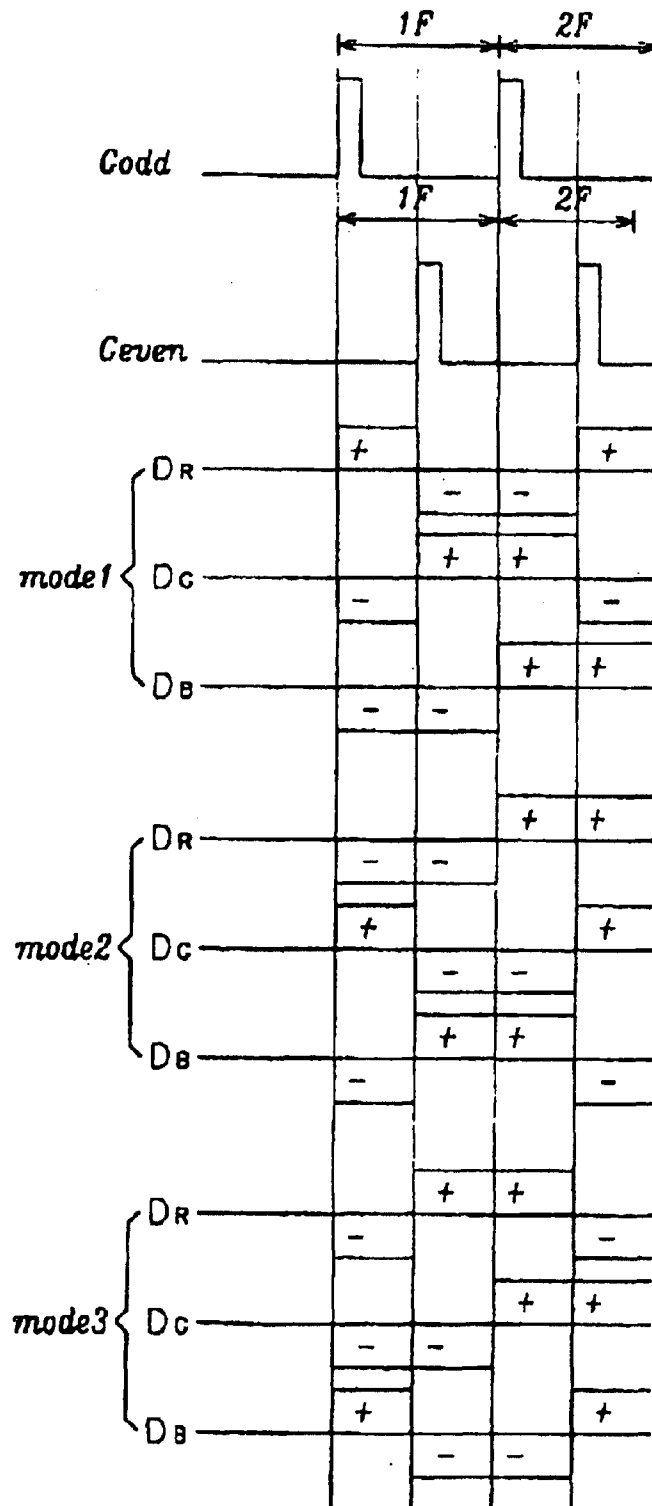

FIG.15A

MODE 1

<i>R</i>	<i>G</i>	<i>B</i>	<i>R</i>	<i>G</i>	<i>B</i>
+	-	-	+	-	-
-	+	-	-	+	-
+	-	-	+	-	-
-	+	-	-	+	-
+	-	-	+	-	-
-	+	-	-	+	-

FIG.15B

MODE 2

<i>R</i>	<i>G</i>	<i>B</i>	<i>R</i>	<i>G</i>	<i>B</i>
-	+	-	-	+	-
-	-	+	-	-	+
-	+	-	-	+	-
-	-	+	-	-	+
-	+	-	-	+	-
-	-	+	-	-	+

FIG.15C

MODE 3

<i>R</i>	<i>G</i>	<i>B</i>	<i>R</i>	<i>G</i>	<i>B</i>
-	-	+	-	-	+
+	-	-	+	-	-
-	-	+	-	-	+
+	-	-	+	-	-
-	-	+	-	-	+
+	-	-	+	-	-

FIG.16

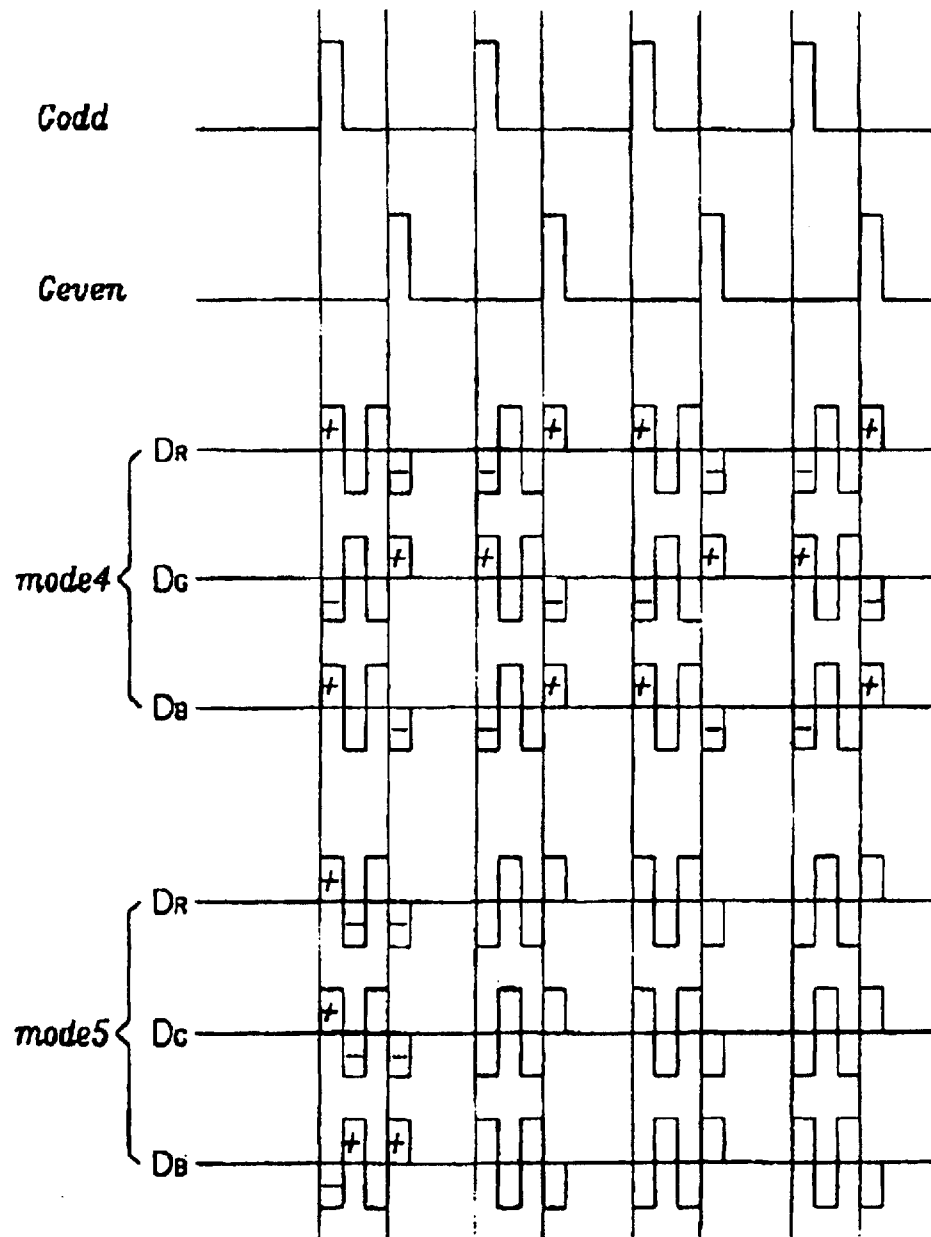

FIG.17A

MODE 4

<i>R</i>	<i>G</i>	<i>B</i>	<i>R</i>	<i>G</i>	<i>B</i>
+	-	+	+	-	+
-	+	-	-	+	-
+	-	+	+	-	+
-	+	-	-	+	-
+	-	+	+	-	+
-	+	-	-	+	-

FIG.17B

MODE 5

<i>R</i>	<i>G</i>	<i>B</i>	<i>R</i>	<i>G</i>	<i>B</i>
+	+	-	+	+	-
-	-	+	-	-	+
+	+	-	+	+	-
-	-	+	-	-	+
+	+	-	+	+	-
-	-	+	-	-	+

FIG.18

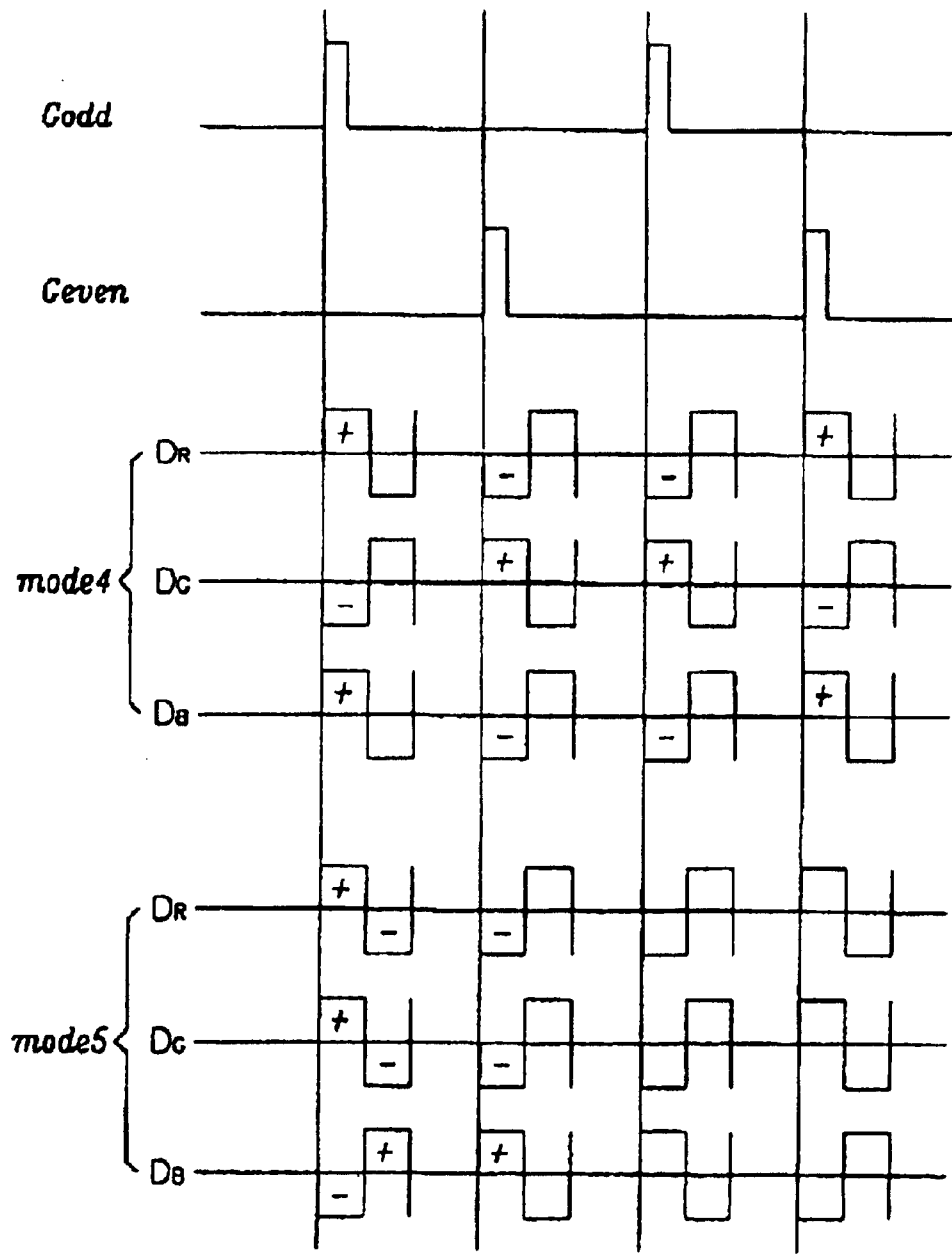
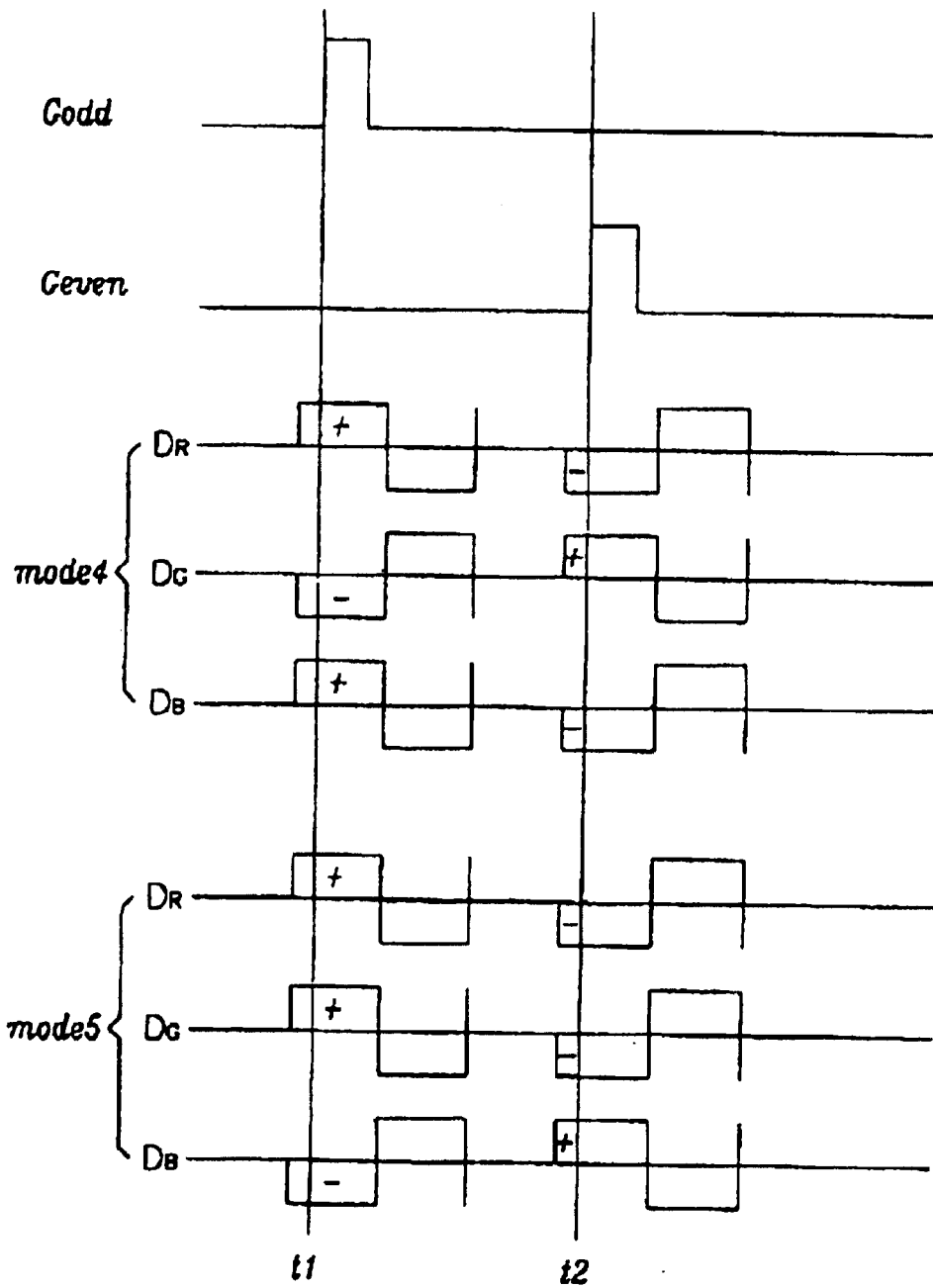

FIG.19



**MULTIPLE TESTING BARS FOR TESTING
LIQUID CRYSTAL DISPLAY AND METHOD
THEREOF**

Matter enclosed in heavy brackets [] appears in the original patent but forms no part of this reissue specification; matter printed in italics indicates the additions made by reissue.

+i CROSS REFERENCE TO PRIOR
APPLICATIONS

The application is a reissue application from U.S. patent application Ser. No. 09/206,317 filed on Dec. 7, 1998 and issued as U.S. Pat. No. 6,734,925 on May 11, 2004, claiming priority to and the benefit of Korean Patent Application No. 1998-49389 filed on Nov. 18, 1998, and Korean Patent Application No. 1997-66154 filed on Dec. 5, 1997.

BACKGROUND OF THE INVENTION

(a) Field of the Invention

The present invention relates to liquid crystal displays (referred as LCDs hereinafter), manufacturing methods thereof and testing methods thereof, in particular, to LCDs having more than two shorting bars, and methods for detecting defects in the LCDs by using the shorting bars.

(b) Description of the Related Art

Shorting bars of a liquid crystal display are used to discharge an electrostatic charges generated in the manufacturing process of the LCD and to test the LCD after the manufacturing process is completed.

A conventional LCD is described in detail with reference to the accompanying drawings.

FIG. 1 is a schematic diagram of a conventional thin film transistor (referred as TFT hereinafter) substrate for an LCD having shorting bars, FIG. 2 is an enlarged view of the part A in FIG. 1 and FIG. 3 is a cross-sectional view taken along line III—III' in FIG. 2.

As shown in FIGS. 1 to 3, gate lines G1, G2, G3, G4, . . . are formed on a substrate 1 and extend in the horizontal direction, and a gate pad 10 is formed at one end of each gate line. A gate shorting bar 20 that electrically connects the gate lines G1, G2, G3, G4, . . . all together and is formed on the substrate 1, extends in the vertical direction, and is located opposite the gate lines G1, G2, G3, G4, . . . with respect to the gate pads 10. A pair of testing pads 2 are formed at both ends of the gate shorting bars 20.

A gate insulating film 15 covers a gate wire 5 such as the gate lines G1, G2, G3, G4, . . . , the gate pads 10 and the gate shorting bar 20. Data lines D1, D2, D3, D4, . . . are formed on the gate insulating film 15 and extends in the vertical direction, and a data pad 30 is formed at one end of each data line. A data shorting bar 40 that electrically connects the data lines D1, D2, D3, D4, . . . all together is formed on the gate insulating film 15, extends in the horizontal direction. A pair of testing pads 3 are formed at both ends of the data shorting bars 40. The gate shorting bar 20 and the data shorting bar 40 may be connected to each other by a resistor.

An insulating film 25 covers a data wire including the data lines D1, D2, D3, D4, . . . , the data pads 30 and the data shorting bar 40, and some portions of the insulation films 15 and 25 on the data pads 30 and the gate pads 10 are removed.

Pixel regions are defined as the area surrounded by the two adjacent gate lines and the two adjacent data lines, and a display area includes the pixel regions. A TFT that runs on by a scan signal from the gate line and transmits image sig-

nals from the data line into the pixel region is formed in each of the pixel regions.

In this structure, electrostatic charges generated in the manufacturing process are discharged or dispersed through the gate shorting bar 20 and the data shorting bar 40.

Meanwhile, after the manufacturing process and the array test are finished, the gate shorting bar 20 and the data shorting bar 40 are removed by cutting the substrate along line L.

Next, the mechanism of a conventional array test is described with reference to FIGS. 1 and 4.

FIG. 4 shows polarities of signals for an array test that are applied to the pixel regions.

Voltages for an array test are applied to the testing pads 2 and 3. Since the gate lines G1, G2, G3, G4, . . . and the data lines D1, D2, D3, D4, . . . are respectively connected to the shorting bars 20 and 40, the TFTs of the pixel regions turn on simultaneously and a testing signal is applied in all R, G, B pixels as shown in FIG. 4. Therefore, in the normally white mode, the pixel regions PX represent dark state.

In case either that the wires are disconnected or that the TFT has a defect, the pixels related to the defects turns to a bright states, and thus the defected elements may be detected with ease. However, if more than two gate lines or data lines, for example, the data lines D2 and D3 in FIG. 1, are short-circuited (S1), it is hard to detect the short-circuited elements since the voltage of the same magnitude and polarity is applied to the two data lines D2 and D3.

Meanwhile, if the shorting bar become divided into more than two and connected different gate lines or data lines to solve the previously described disadvantage, the detecting capability may increase. However, the protecting capability against electrostatic charges may decrease.

SUMMARY OF THE INVENTION

It is an object of the present invention to provide a TFT array panel having shorting bars that are superior in detecting short-circuit defects as well as discharging electrostatic charges.

It is another object of the present invention to provide a test methods to detect short-circuit defects between adjacent data lines or adjacent gate lines and pixel defects with ease.

It is another object of the present invention to provide a test method to effectively detect some defects in a high-resolution substrate.

To achieve these objects of the present invention, a plurality of gate lines are formed in parallel with one another and two shorting bars for tests are formed in a manner to respectively link every other gate lines. A main shorting bar linking all gate lines is formed outside the shorting bars.

The gate lines and the shorting bars for test may be coupled by conductive coupling patterns.

A plurality of data lines may be formed in perpendicular to the gate lines, three shorting bars for tests may respectively link to the sequences of the data lines one after another and the data shorting bars and the data lines may be coupled to each other by conductive coupling patterns.

Moreover, it is desirable that the gate lines and the data lines link all together outside the data shorting bars by the main shorting bar.

In a method of manufacturing the LCD, the conductive coupling patterns are formed at the step of forming transparent pixel electrodes.

The gate lines and the data lines may be separated from the main shorting bar after the conductive coupling patterns are formed.

According to the LCDs and the manufacturing methods of the present invention, the additional gate shorting bars or the additional data shorting bars are formed and separated from the main shorting bar after the process is over. Accordingly, the LCD substrate is superior in detecting short-circuited defects of the substrate as well as in discharging the electrostatic charges.

In testing methods according to embodiments of the present invention, gate pulses are applied to two secondary lines for tests that are respectively connected to even gate lines and to odd gate lines and data signals are applied to three secondary lines for test that are respectively connected to one of R, G and B pixels in sequence. In detail, a signal having the first polarity is applied to two of three adjacent data lines and a signal having the opposite polarity of the first is applied to the rest of the three adjacent data lines when the pulse is applied to the even gate lines. Then, the signal having the first polarity is applied to two of the three adjacent data lines chosen in a different combination concerning to the first choice and the signal having the opposite polarity of the first is applied to the rest of the three adjacent data lines.

In this test method according to the present invention, it is possible to detect short-circuited defects between adjacent pixels or adjacent wires, and the detecting ability of visual defects and the reliability are increased.

BRIEF DESCRIPTION OF THE DRAWINGS

FIG. 1 is a schematic diagram of a thin film transistor (TFT) substrate for a LCD having shorting bars according to the conventional invention;

FIG. 2 is an enlarged layout view of a portion A in FIG. 1;

FIG. 3 is a cross-sectional view taken along line III—III' in FIG. 2.

FIG. 4 is a schematic diagram of pixel matrix in which array test signals are applied;

FIG. 5 is a schematic diagram of a TFT array panel for LCDs having shorting bars according to the present invention;

FIG. 6 is an enlarged layout view of a portion B in FIG. 5 according to the first embodiment of the present invention;

FIG. 7 is another enlarged layout view of a portion B in FIG. 5 according to the second embodiment of the present invention;

FIG. 8 is a cross-sectional view taken along line VIII—VIII' in FIG. 7;

FIG. 9 is an enlarged layout view of a portion C in FIG. 5;

FIG. 10 is a cross-sectional view taken along line X—X' in FIG. 9;

FIGS. 11A to 11F are cross sectional views of the LCD substrate as a manufacturing process according to the embodiment shown in FIGS. 7 and 8;

FIGS. 12A to 12F are cross sectional views of the LCD substrate as a manufacturing process according to the embodiment shown in FIGS. 9 and 10;

FIG. 13 is a schematic diagram which illustrates the manner of connections between a wire and shorting bars according to the present invention;

FIG. 14 illustrates wave forms of array test signals applied to gate lines and data lines according to the first embodiment;

FIGS. 15A to 15C illustrate polarities of signals applied to R, G, B pixels according to the first embodiment;

FIG. 16 illustrates wave forms of array test signals applied to gate lines and data lines according to the second embodiment;

FIGS. 17A to 17B illustrate polarities of signals applied to R, G, B pixels according to the second embodiment;

FIG. 18 illustrates wave forms of array test signals applied to gate lines and data lines according to the third embodiment;

FIG. 19 illustrates wave forms of array test signals applied to gate lines and data lines according to the fourth embodiment.

DETAILED DESCRIPTION OF THE PREFERRED EMBODIMENTS

The present invention now will be described more fully hereinafter with reference to the accompanying drawings, in which preferred embodiments of the invention are shown. This invention may, however, be embodied in many different forms and should not be construed as limited to the embodiments set forth herein. In the drawings, the thickness of layers and regions are exaggerated for clarity. Like numbers refer to like elements throughout. It will be understood that when an element such as a layer, region or substrate is referred to as being "on" another element, it can be directly on the other element or intervening elements may also be present.

LCDs and methods of manufacturing the same will be described hereinafter with reference to FIG. 5.

FIG. 5 is a schematic diagram of a TFT array panel for an LCD having shorting bars according to embodiments of the present invention, in which wires for electrostatic discharge protection and for detecting defects are not removed yet.

Gate lines G1, G2, G3, G4, . . . made of a material such as Al extends in the horizontal direction and gate pads 110, 120, 130, 140, . . . are formed at one ends of respective gate lines. Data lines D1, D2, D3, D4, . . . made of Cr or Mo are formed on an insulating film (not shown) that covers the gate lines, and extend in the vertical direction. Data pads 510, 520, 530, 540, . . . are formed at one ends of respective data lines.

A plurality of pixel regions PX are defined as the area surrounded by the two adjacent gate lines and the two adjacent data lines, and a display area includes the pixel regions. A TFT is formed in each pixel region so that the image signals from the data lines D1, D2, D3, D4, . . . can be transmitted into the pixels when the scan signals from the gate lines G1, G2, G3, G4, . . . turn on the TFTs.

Electrostatic charges usually generated in the step of forming those wires may cause defects of the TFTs, the gate or the data wires of the pixel regions PX. To avoid those defects, a gate shorting bar 200 and a data shorting bar 400 are required.

The gate shorting bar 200 made of the same material as the gate wire extends in the vertical direction, located outside the display region and connected to the gate extensions 101, 102, 103, 104 that extend from the gate pads 110, 120, 130, 140 in the horizontal direction. The data shorting bar 400 made of the same material as the data wire extends in the horizontal direction, located outside the display region and connected to the data extensions 501, 502, 503 and 504 that extend from the data pads 510, 520, 530 and 540 in the vertical, direction. The gate shorting bar 200 and the data shorting bar 400 are connected to each other through a contact hole in the insulating film.

The gate shorting bars 200 and the data shorting bar 400 discharge and disperse the electrostatic charges generated in the wires of the substrate during the manufacturing process. They are removed from the substrate by cutting the substrate along a cutting line L1.

Next, the array test for the display area is performed.

The array test is performed by using secondary lines **410** and **420**; **210**, **220** and **230**.

A first secondary line **410** and a second secondary line **420** made of the data metal such as Cr and Mo are arranged between the gate shorting bar **200** and the gate pads **110**, **120**, **130** and **140** and parallel to the gate shorting bar **200**. A third secondary line **210**, a fourth secondary line **220** and a fifth secondary line **230** made of the gate metal such as Al are arranged between the data shorting bar **400** and the data pads **510**, **520** and **530** and parallel to the data shorting bar **400**. The first secondary line **410** and the second secondary line **420** are respectively connected to odd gate lines G1 and G3 and to even gate lines G2 and G4. The third secondary line **210**, the fourth secondary line **220** and the fifth secondary line **230** are respectively connected to (3n-2)th data lines, (3n-1)th data lines and (3n)th data lines.

Accordingly, it is possible to detect some defects in the substrate by applying different signals to even gate lines and to odd gate lines through the first secondary line **410** and the second secondary line **420** and by applying R, G and B signals to the (3n-2)th data line, (3n-1)th data line and (3n)th data lines.

Now, the structure of the gate shorting bar **200**, the first and the second secondary lines **410** and **420**, the data shorting bar **400** and the third, the fourth, and the fifth secondary lines **210**, **220** and **230** will be described in detail with reference to FIG. 6 to FIG. 10.

FIGS. 6 and 7 are enlarged layout views of a portion B in FIG. 5 according to a first embodiment and a second embodiment of the present inventions. FIG. 8 is a cross-sectional view taken along line VIII—VIII' in FIG. 7, in which the connection between a gate shorting bar and secondary lines is shown.

Gate extensions **101**, **102**, and **103** extends from gate pads **110**, **120** and **130** formed on a substrate **1** to vertically extended gate shorting bars **200** on the substrate **1**. A gate insulating film **150** is formed thereon, and a first secondary line **410** and a second secondary line **420** are formed on the gate insulating film **150**. The first and the second secondary lines **410** and **420** are located between the gate pads **100**, **110** and **120** and the gate shorting bar **200** in parallel to the gate shorting bar **200**. A passivation film **250** is formed thereon.

Connecting members **310** and **320**, which are made of the same material as pixel electrodes (not shown), are formed on the passivation film **250** at which the gate extensions overlap the first secondary line or the second secondary lines. The connecting member **310** is connected to the first secondary line **410** through a contact hole (a) in the passivation film **250** and to the gate extension **101** through a contact hole (b) in the passivation film **250** and the gate insulating film **150**. The connecting member **320** is connected to the second secondary line **420** through a contact hole (c) in the passivation film **250** and to the gate extension **102** through a contact hole (d) pierced in the passivation film **250** and the gate insulating film **150**. That is, the gate extensions **101** and **102** are respectively connected to the first and the second secondary lines **410** and **420** by the connecting members **310** and **320**.

As previously described, the gate shorting bar is electrically separated from the secondary lines **410** and **420** by cutting the substrate along the cutting line L1 before array tests, and the secondary lines **410** and **420** are removed by cutting along the cutting line L2 outside the display region after the array tests.

A second embodiment shown in FIG. 7 has a structure in which the additional step of removing the gate shorting bar is not required before the array tests.

The structure of the connection between the first and the second secondary lines **410** and **420** and the gate extensions **101**, **102** and **103** in the second embodiment is similar to the structure in the first embodiment, but each gate extension is separated from the gate shorting bar **200** in a manner that some portions of the gate extensions **101**, **102** and **103**, the gate insulating film **150** and the passivation film **250** between the gate shorting bar **200** and the first secondary line **410** are removed. The gate extensions **101**, **102** and **103** are separated from the gate shorting bar **200** in the final manufacturing step and it will be described more in detail afterward.

In the second embodiment, the step of cutting the substrate before the array test is not required because the gate shorting bar **200** and the secondary lines **410** and **420** are already separated from each other.

Instead, after the test, the secondary lines **410** and **420** are removed simultaneously by cutting the substrate along the cutting line L2 as in the first embodiment.

FIG. 9 is an enlarged layout view of a portion C in FIG. 5. FIG. 10 is a cross-sectional view taken along line X—X' in FIG. 9, which specially show the connection of a data shorting bar to a third secondary line, a fourth secondary line and a fifth secondary line.

As shown in FIGS. 9 and 10, a third, a fourth and a fifth secondary lines **210**, **220** and **230** made of the same metal as a gate wire are formed on a substrate **1** in the horizontal direction, and a gate insulating film **150** is deposited thereon. A data wire **55**, including data lines D1, D2, D3 and D4, data pads **510**, **520**, **530** and **540**, data extensions **501**, **502**, **503** and **504** extending from the data pads and a data shorting bar **400** connected to the data extensions, is formed on the gate insulating film **150**. A passivation film **250** is formed thereon.

Contact holes F, H and J are formed in the passivation film **250** over the respective data extensions **501**, **502** and **503** and contact holes G, I and K are formed in the passivation film **250** and the gate insulating layer **150** over the respective third, fourth and fifth secondary lines **210**, **220** and **230**. Connecting members **301**, **302** and **303** formed on the passivation film **250** respectively connect the third, the fourth and the fifth secondary lines **210**, **220** and **230** to every other third data extensions **501**, **502** and **503** through the contact holes F, H, J; G, I, K.

Furthermore, the passivation film **250** and the data extensions **501**, **502**, **503** and **504** are removed between the data shorting bar **400** and the data pads **510**, **520**, **530** and **540**, that is, the data extensions **501**, **502**, **503** and **504** are disconnected from the data shorting bar **400**. As a result, the additional step of cutting the data shorting bar **400** is not required for the array test.

As previously described, three other signals can be applied to the third, fourth and the fifth secondary lines **210**, **220** and **230** for detecting pixel defects and short-circuited defects of the TFT array panel since each of the three secondary lines **210**, **220**, **230** is connected to every other third data extension.

In case more than two data lines D3 and D4 are shorted as shown in FIG. 5, if the different signals are applied to the data lines D2 and D3, the short-circuited defects are detected easily by the differences of luminance from the other pixels.

Even though there are three separated secondary lines **210**, **220** and **230** in this embodiment, two or more than three secondary lines may be formed.

Next, methods of manufacturing an LCD according to the embodiments of the present invention will be described with reference to FIGS. 11A to 11F and FIGS. 12A to 12F hereinafter.

FIGS. 11A to 11F are cross sectional views of the intermediate structures of an LCD panel shown in FIGS. 7 and 8, and FIGS. 12A to 12F are cross sectional views of the intermediate structure of an LCD panel shown in FIGS. 9 and 10.

As shown in FIGS. 11A and 12A, a metal layer is deposited on an insulating substrate 1 and patterned to form a gate wire including gate lines G1, G2, G3 and G4, gate pads 100, 110 and 120, a gate shorting bar 200, gate extensions 101, 102 and 103 and secondary lines 210, 220 and 230. Then, a gate insulating film 150, an amorphous silicon film (not shown) and a doped silicon film (not shown) are deposited consecutively, and the upper two films are patterned to form an active pattern.

As shown in FIGS. 11B and 12B, a metal layer is deposited and patterned to form a data wire 55 including data lines D1, D2, D3 and D4, a source and a drain electrode (not shown), data pads 500, 510, 520 and 530, a data shorting bar 400, data extensions 501, 502, 503 and 504 and secondary lines 410 and 420. Then, the portions of the doped silicon film is etched by using the data wire 55 as a mask.

As shown in FIGS. 11C, 11D, 12C and 12D, a passivation film 50 is deposited. Then, the passivation film 50 and the gate insulating film 150 are etched to form contact holes E and M exposing the gate pads 110 and 120 and the data pads 510, 520 and 530, and contact holes A, B, C, D, F, G, H, I, J and K exposing the first through the fifth secondary lines 410, 420, 210, 220, 230, the gate extensions 101, 102 and the data extensions 501, 502, 503.

Next, indium-tin-oxide(ITO) is deposited and etched to form pixel electrodes. In the etching process, a first and a second connecting members 310 and 320, and a third, a fourth and a fifth connecting members 301, 302 and 303 are simultaneously formed. The first and the second connecting members 310 and 320 respectively connect the first and the second secondary line 410 and 420 to the gate extensions 101 and 102 through the contact holes A, C, B, D. The third, the fourth and the fifth connecting members 301, 302 and 303 respectively connect the third, the fourth and the fifth secondary line 210, 220 and 230 to every other third data extensions 501, 502 and 503 through the contact holes G, I, K, F, H and J.

As shown in FIGS. 11F and 12F, the gate shorting bar 200 is disconnected from the gate extensions 101, 102 and 103 between the first secondary line 410 and the gate shorting bar 200, and the data shorting bar 400 is disconnected from the data extensions 501, 502 and 503 between the third secondary line 210 and the data shorting bar 400.

More in detail, the gate extensions 101 and 102 between the first secondary line 410 and the gate shorting bar 200, and the data extensions 501, 502 and 503 between the third secondary line 210 and the data shorting bar 400 are exposed in the step of etching the passivation film 250. After connecting members 301, 302, 303, 310 and 320 are formed, the exposed portions of the extended lines 101, 102, 501, 502 and 503 are etched and removed. The gate shorting bar 200 and the data shorting bar 400 may be removed by cutting along the cutting line L1 before the array tests.

As previously described, since two adjacent gate lines are connected to two different secondary lines and three adjacent data lines are connected to three different secondary lines, it is easy to test visual quality of the LCD.

Now, the connecting structure between the secondary lines and the gate lines is described again.

As shown in FIG. 13, a plurality of gate lines G1, G2, G3, G4, G5 and G6 and a plurality of data lines D1, D2, D3, D4, D5 and D6 intersect to define a plurality of pixels arranged in a matrix.

Since odd gate lines G1, G3 and G5 and even gate lines G2, G4 and G6 are separately connected to the first and to the second secondary lines 410 and 420, it is possible to apply different signals to the odd pixel row and to the even pixel row.

Three adjacent data line, that is, (3n-2)th, (3n-1)th and (3n)th data lines are connected to the pixels in different rows and arranged in three shifts, for example, R, G, B pixel columns. Since the third, the fourth and the fifth secondary lines are separately connected, three other signals can be applied to the three adjacent pixel columns through the secondary lines 210, 220 and 230.

Testing pads 4, 5, 6, 7 and 8 are respectively formed at the ends of the secondary lines 410, 420, 210, 220 and 230.

Then, a visual test method according to the first embodiment is described with references to FIGS. 13, 14 and 15A to 15C.

FIG. 14 illustrates wave forms of array test signals applied to gate and data lines through the respective secondary lines and FIGS. 15A to 15C illustrate polarities of signals applied to R, G, B pixels in modes 1 to 3.

As shown in FIGS. 13 and 14, signal voltages G_{odd} and G_{even} are applied to a plurality of gate lines in odd rows and a plurality of gate lines in even rows. Signal voltages D_R , D_G and D_B are respectively applied to a plurality of (3n-2)th, (3n-1)th and (3n)th data lines through the first to the fifth secondary lines 410, 420, 210, 220 and 230.

Then, the signal voltages are described more in detail hereinafter.

Signal voltages G_{odd} and G_{even} , which respectively include pulses turning on thin film transistors, are applied to odd gate lines and to even gate lines through the first and the second secondary lines 410 and 420. If the period from the moment one pulse is applied to the moment next pulse is applied is defined as one frame, the signal voltage G_{even} for the even gate lines follows the signal voltage G_{odd} for the odd gate lines by a half frame. As a result, the TFTs in even row pixels are turned on with a half frame difference against the TFTs in odd row pixels.

Meanwhile, polarities of the data signal voltages D_R , D_G and D_B which are respectively applied to R, G, B pixel columns invert once a frame and at the moment that the pulses are applied to the odd or the even gate lines. As described more in detail, the signal voltages applied to the selected two of R, G, B pixel columns invert at the same time and the polarities of the signals are opposite. For example, as shown in FIG. 14, signals having the same polarity are applied to the two of the three pixel columns and invert at the moment that the even gate pulses are applied. A signal having an opposite polarity is applied to the rest of the three pixel columns and inverts at the moment that the odd gate pulse is applied.

FIG. 14 shows signals in the three modes.

First, in the first mode (mode 1), the test signal D_R applied to R pixel column and the test signal D_G applied to G pixel column have opposite polarities and invert when the pulse is applied to the even gate line, and the test signal D_B applied to B pixel column invert when the pulse is applied to the odd gate line. The polarities of the test signals D_R , D_G and D_B are respectively (+), (-) and (-) when the first frame (1F) starts.

Then, in the second mode (mode 2), the test signals D_R , D_G and D_B applied to the R, G and B pixel columns are the same as the test signals D_B , D_R and D_G applied to the B, R and G pixel columns in the first mode (mode 1).

Moreover, in the third mode (mode 3), the test signals D_R , D_G and D_B applied to the R, G and B pixel columns are the

same as the test signals D_G , D_B and D_R applied to the G, B and R pixel columns in the first mode (mode 1) and the test signals D_B , D_R and D_G applied to the B, R and G pixel columns in the second mode (mode 2).

Then, polarities of the pixels when the above signals are applied to each of the pixels will be described.

First, if the pulse is applied to odd gate lines, TFTs of the pixels in odd rows are turned on and the test signals are applied to pixels in odd rows. When the TFTs of the pixels in odd rows are turned off and the pulse is applied to even gate lines, the test signals are applied to pixels in even rows through the turned-on TFTs of the pixels in even rows.

Therefore, the polarities of the pixels in the first frame (1F) of the first to the third modes are illustrated as in the FIGS. 15A to 15C. The polarities in the second frame (2F) are the opposite.

As shown in FIG. 15A, in the first mode (mode 1), one of the pixels in R pixel column and one of the pixels in G pixel column respectively have (+) and (-), or (-) and (+) polarities, and the polarities invert according to the columns. However, all the pixels in B pixel column have the same polarity (-). In case of the row direction, the G and B pixels in odd rows have the same polarity and the R pixels in odd rows have the polarity opposite to the R and G pixels. Though, the B and R pixels in even rows have the same polarity and the G pixels in odd rows have the polarity opposite to the B and R pixels.

Then, as shown in FIG. 15B, in the second mode (mode 2), one of the pixels in G pixel column and one of the pixels in B pixel column respectively have (+) and (-), or (-) and (+) polarities, and the polarities invert according to the columns. All the pixels in the R pixel column have the same polarity (-). In case of the row direction, the B and R pixels in odd rows have the same polarity and the G pixels in odd rows have the polarity opposite to the B and R pixels. The R and G pixels in even rows have the same polarity and the R pixels in odd rows have the polarity opposite to the R and G pixels.

Furthermore, as shown in FIG. 15C, in the third mode (mode 3), one of the pixels in R column and one of the pixels in B column respectively have (+) and (-), or (-) and (+) polarities, and the polarities invert according to the columns. All the pixels in G column have the same polarity (-). In case of the row direction, the R and G pixels in odd rows have the same polarity and the B pixels in odd rows have the polarity opposite to the R and G pixels. The G and B pixels in even rows have the same polarity and the R pixels in odd rows have the polarity opposite to the G and B pixels.

It is possible to detect the short-circuited defects between two adjacent gate lines or two adjacent data lines by adopting one of the three modes. In case that the short-circuited defects occurs between two adjacent pixels to which the different signals having the opposite polarities are applied, the signal voltages applied to the pixels are shifted to one value, the means of the two voltages. As a result, the same voltage is applied to the pixels. Therefore, it is possible to determine the short-circuited defects since the same gray image is displayed in the adjacent short-circuited pixels. Moreover, in case in which the short-circuited defects occur between the adjacent wires, it is easy to detect the short-circuited defects between the wires since the same signal is applied to the pixels of the rows or the columns which are connected to the short-circuited wires.

However, it is difficult to detect the short-circuited defects between the adjacent pixels to which the same testing signal is applied and to determine the exact location of the same.

To solve this problem, if any two of the three modes are adopted for the test, it is possible to easily detect the pixel defects such as short-circuited defects between the adjacent pixels and to determine the location of the defects, since different kinds of polarities are applied to the adjacent pixels in a row direction and in a column direction at least one time.

Furthermore, in the testing method according to the first embodiment, it is effective to test a visual uniformity since the polarities of the signals D_R , D_G and D_B applied to the respective secondary lines 210, 220 and 230 last for one frame and the signal fluctuation is ignorable.

Now, a visual test method according to the second embodiment is described with reference to FIGS. 16, 17A and 17B.

FIG. 16 illustrates wave forms of array test signals applied to gate and data lines according to the second embodiment, and FIGS. 17A to 17B illustrate polarities of signals applied to R, G, B pixels according to the second embodiment.

Signal voltages G_{odd} and G_{even} , and D_R , D_G and D_B as shown in FIG. 16 are respectively applied to gate lines in odd and in even pixel rows and (3n-2)th, (3n-1)th and (3n)th data lines through the first to the fifth secondary lines 410, 420, 210, 220 and 230.

Like the first embodiment, if the period from the moment one pulse is applied to the moment next pulse is applied is defined as one frame, the signal voltage G_{even} for the even gate lines follows the signal voltage G_{odd} for the odd gate lines by a half frame.

Meanwhile, data signal voltages D_R , D_G and D_B applied to R, G and B pixel columns invert several times in a frame with the same period as the width of the pulse. The polarities of the signal voltages D_R , D_G and D_B invert at the moments that the gate pulses are respectively applied to the odd gate lines and to the even gate lines, and the polarity at the moment that the pulse is applied to the odd gate lines is opposite to the polarity at the moment that the pulse is applied to the even gate lines. The signals having the same polarity are applied to any two of the R, G and B pixel columns, and the signal having the polarity opposite to the two pixel columns is applied to the rest of the R, G and B pixel columns.

FIG. 16 shows the signals of two modes.

In the fourth mode (mode 4), the same test signals D_R and D_B having the same polarity and the same inversion period are applied to the pixels in R pixel column and the pixels in B pixel column, and a test signal D_G having the same inversion period as the test signals D_R and D_B and the opposite polarity is applied to the pixels in G pixel column.

Then, in the fifth mode (mode 5), the same test signals are applied to the pixels in R pixel column and in G pixel column and the test signal having the opposite polarity is applied to the pixels in B pixel column.

FIGS. 17A and 17B show the polarities in the pixels when the signals are applied according to the fourth and the fifth modes.

In the fourth mode shown in FIG. 17A, all adjacent pixels in a column direction have the polarities opposite to each other and all adjacent pixels except the adjacent B and R pixels in a row direction have the opposite polarities.

In the fifth mode shown in FIG. 17B, all adjacent pixels in the column direction have the polarities opposite to each other and all the adjacent pixels except the adjacent R and G pixels in the row direction have the opposite polarities.

As described in the first embodiment, it is possible to detect the short-circuited defects by using one of the two

11

modes in the second embodiment. When both of the two modes are adopted, the detecting ability is increased so that pixel defects such as the short-circuited defects between the adjacent pixels to which the test signal having the same polarity is applied are easily detected.

In the defect detecting method according to the second embodiment, since polarities of the test signals applied to R, G and B pixel columns invert with the same period as the width of the gate pulse, the signals is not charged into the pixels sufficiently. As a result, flicker effects may occur. In addition, it is not suitable to test for visual uniformity that is usually confirmed by naked eyes, and it is difficult to detect the pixel defects under the high state or off state.

FIG. 18 shows testing wave forms according to the third embodiment to improve this problem.

In FIG. 18, signals D_R , D_G and D_B applied to R, G and B pixel columns and signals G_{odd} and G_{even} applied to odd and even gate lines are mostly similar to the signals in the second embodiment. Instead, the signals applied to the R, G and B pixel columns invert with a period of two times the width of the gate pulse.

Therefore, there is no difficulty in charging the R, G and B signals into the pixels, it is easy to synchronize the gate pulse and the data signals, and the flicker effect is reduced. As a result, the test method according to the third embodiment is superior in testing a uniformity and defects under high and off states.

FIG. 19 illustrates wave forms of array test signals according to the fourth embodiment, in which pulses are applied to the odd gate lines and to the even gate lines and the two pulses are synchronized with a half frame difference. Test signals invert with a period of twice the width of the gate pulse.

In the fourth embodiment, the gate pulse is applied later than the moment (t1, t2) when the signals D_R , D_G and D_B applied to the R, G and B pixel columns invert. Therefore, the signals can be charged with a large initial charging values when TFTs are turned on. As a result, the charging time decreases and the signals can be charged sufficiently while the gate pulse is applied. Therefore, it is easy to test even a high resolution substrate.

As described above, in the LCD according to the present invention, since gate secondary shorting bars or data secondary shorting bars are respectively formed with more than two divided lines and separated from a gate shorting bar and a data shorting bar, the substrate is superior against electrostatic charges. In addition, since different test signals can be applied to the gate and the data secondary shorting bars, the detecting ability for the substrate is increased. As a result, it is possible to reduce a manufacturing cost because the substrate in which the defects occurred is not continued to the next step, but discarded in the testing step. In addition, it is possible to easily test a high resolution substrate by starting charging data signals before the moment the gate pulse is applied in order to sufficiently charge the data signals to pixels.

In the drawings and specification, there have been disclosed typical preferred embodiments of the invention and, although specific terms are employed, they are used in a generic and descriptive sense only and not for purpose of limitation, the scope of the invention being set forth in the following claims.

What is claim is:

1. A thin film panel comprising:

a plurality of gate lines formed on [the] a substrate and extending in a horizontal direction, the plurality of gate lines comprising a first group and a second group;

12

a gate insulating film formed on the plurality of gate lines and [having] comprising a plurality of first contact holes exposing portions of the plurality of gate lines;

a plurality of data lines formed on the gate insulating film, extending in a vertical direction and intersecting the plurality of gate lines;

a first testing bar formed on the gate insulating film, extending in the vertical direction;

a second testing bar formed on the gate insulating film and substantially parallel to the first testing bar;

a passivation film formed on the plurality of data lines, the first testing bar and the second testing bar, and [having] comprising a plurality of second contact holes exposing the plurality of first contact holes and a plurality of third contact holes and a plurality of fourth contact holes exposing the first testing bars and the second testing bars, respectively;

a plurality of first connecting members formed on the passivation film and in direct contact with the first group of the gate lines through the plurality of first contact holes and the plurality of second contact holes and with the first testing bar through the plurality of third contact holes; and

a plurality of second connecting members formed on the passivation film and in direct contact with the second group of the gate lines through the plurality of first contact holes and the plurality of second contact holes and with the second testing bar through the plurality of fourth contact holes.

2. The thin film panel of claim 1, further comprising:

a third, a fourth and a fifth testing bars formed on the substrate and extending in the horizontal direction;

a third, a fourth and a fifth connecting members formed on the passivation film,

wherein the third, the fourth and the fifth connecting members respectively connect the data lines to the third, the fourth and the fifth testing bars.

3. The thin film panel of claim 2, wherein the passivation film has fifth contact holes exposing the data lines, and the passivation film and the gate insulating film has sixth, seventh and the eighth contact holes respectively exposing the third, the fourth and the fifth testing bars, wherein the third, the fourth and the fifth connecting members are respectively connected to the data lines through the fifth contact holes, and to the third, the fourth and the fifth testing bars through the sixth, the seventh and the eighth contact holes.

4. The thin film panel of claim 1, further comprising a gate shorting bar formed on the substrate and connected to the gate lines.

5. The thin film panel of claim 4, further comprising a data shorting bar formed on the gate insulating film and connected to the data lines.

6. The thin film panel of claim 5, wherein the data shorting bar is electrically connected to the gate shorting bar.

[7. The thin film panel of claim 5, wherein the data shorting bar is electrically connected to the gate shorting bar.]

8. The thin film panel of claim 7, further comprising a data shorting bar formed on the gate insulating film, extending in the horizontal direction, located opposite the data lines with respect to the third, the fourth and the fifth shorting bars and separated from the data lines.

9. The thin film panel of claim 8, wherein the data shorting bar is electrically connected to the gate shorting bar.

10. The thin film panel comprising:

a plurality of gate lines formed on the substrate and extending in a horizontal direction;

13

a first testing bar formed on the substrate and extending in the horizontal direction;

a second testing bar formed on the substrate substantially parallel to the first testing bar;

a gate insulating film formed on the gate lines and the first and the second testing bars, and [having] comprising a first contact hole and a second contact hole exposing the first testing bar and the second testing bar, respectively;

a plurality of data lines formed on the gate insulating film, extending in a vertical direction, and intersecting the gate lines;

a passivation film covering the data lines and the first testing bar and the second testing bar, and [having] comprising a third contact hole and a fourth contact hole on the first contact hole and the second contact hole, respectively, and fifth contact holes exposing the data lines;

a first connecting member formed on the passivation film and in direct contact with a first group of the data lines through *one of the* [first and the third] *fifth* contact holes and with the first testing bar through the [fifth] *first and the third* contact [hole] *holes*; and

a second connecting member formed on the passivation film and in direct contact with a second group of the data lines, which are not connected to the first connecting member, through *another one of the* [second and the fourth] *fifth* contact holes, and with the second testing bar through the [fifth] *second and the fourth* contact [hole] *holes*.

11. The thin film panel of claim 10, further comprising a gate shorting bar formed on the substrate and connected to the gate lines.

12. The thin film panel of claim 11, further comprising a data shorting bar formed on the gate insulating film and connected to the data lines.

13. The thin film panel of claim 12, wherein the data shorting bar is electrically connected to the gate shorting bar.

14. The thin film panel of claim 10, further comprising a data shorting bar formed on the gate insulating film, extending in the horizontal direction, located opposite the data lines with respect to the first and the second [shorting] *testing* bars and separated from the data lines.

15. The thin film panel of claim 14, further comprising a gate shorting bar formed on the substrate, extending in the vertical direction and separated from the gate lines.

16. The thin film panel of claim 15, wherein the gate shorting bar is electrically connected to the data shorting bar.

17. A manufacturing method of a thin film panel, the method comprising:

depositing a metal layer on a substrate;

patterning the metal layer to form gate lines;

forming a gate insulating film on the gate lines;

forming data lines and a first and a second shorting bars for testing the gate lines on the gate insulating film;

depositing a passivation film;

etching the passivation film and the gate insulating film to form first contact holes and a second *contact hole* and a third contact [holes] *hole* respectively exposing the gate lines and the first and the second shorting bars;

depositing a conductive layer; and

patterning the conductive layer to form a pixel electrode, a first connecting member connected to *one of the* gate lines and the first shorting bar through *one of the* first *contact holes* and the second contact holes, and a sec-

14

ond connecting member connected to *another one of the* gate [line] *lines* and the second shorting bar through *another one of the* first *contact holes* and the third contact holes.

18. The manufacturing method of a thin film panel of claim 17, further comprising forming a [third] *gate* shorting bar for electrostatic discharge protection connected to the gate lines by patterning the metal layer.

19. The manufacturing method of a thin film panel of claim 18, further comprising disconnecting the [third] *gate* shorting bar from the gate lines after forming the first and the second connecting members.

20. A manufacturing method of a thin film panel, the method comprising:

forming gate lines, a first, a second and a third shorting bars for testing data lines on a substrate;

forming a gate insulating film;

depositing a metal layer on the gate insulating film;

patterning the metal layer to form data lines;

depositing a passivation film;

etching the passivation film and the gate insulating film to form first, second, third and fourth contact holes exposing the data line, the first, the second and the third shorting bars;

depositing a conductive layer; and

patterning the conductive layer to form a pixel electrode and connecting members, the connecting members connected to the data lines through the first contact holes and to the first, the second and the third shorting bars through the second, the third and the fourth contact holes.

21. The manufacturing method of a thin film panel of claim 20, further comprising forming a [fourth] *data* shorting bar for electrostatic discharge protection connected to the data lines by patterning the metal layer.

22. The manufacturing method of a thin film panel of claim 21, further comprising disconnecting the [fourth] *data* shorting bar from the data lines after forming the first, the second and the third connecting members.

23. A manufacturing method of a thin film panel, the method comprising the steps of:

forming a wire including a plurality of gate lines, a plurality of data lines, a main shorting bar for electrostatic discharge protection which is connected to the gate lines and the data lines, a first and a second shorting bars for testing the gate lines, a third and a fourth shorting bars for testing the data lines, wherein the first and the second shorting bars are alternately connected to the gate lines and the third and the fourth shorting bars are respectively connected to the every other data lines; separating the main shorting bar from the gate and the data lines; and

applying voltages to the first, the second, the third and the fourth shorting bars for detecting defects of the data lines and the gate lines.]

24. The manufacturing method of a thin film panel of claim 23, wherein the voltages applied to the first shorting bar and the second shorting bar are different.]

25. The manufacturing method of a thin film panel of claim 23, wherein the voltages applied to the third shorting bar and the fourth shorting bar are different.]

26. The manufacturing method of a thin film panel of claim 23, further comprising removing the first, the second, the third and the fourth shorting bars after the step of applying voltages.]

15

27. A thin film panel comprising:
 a plurality of first signal lines transmitting first signals and extending in a direction substantially parallel to each other;
 a plurality of second signal lines transmitting second signals and extending substantially parallel to the first signal lines;
 a first testing bar located near one ends of the first signal lines;
 a second testing bar located near one ends of the second signal lines, substantially parallel to the first testing bar, and separated from the first testing bar;
 a plurality of first conductive extensions connected between the first testing bar and the first signal lines, respectively; and
 a plurality of second conductive extensions connected between the second testing bar and the second signal lines, respectively,
 wherein the first and the second conductive extensions have cutouts for electrical disconnection.

16

28. The panel of claim 27, wherein the first testing bar is located opposite the first and the second signal lines with respect to the second testing bar.

29. The panel of claim 28, wherein the first and the second signal lines and the first and the second conductive extensions [include] *comprise* a first layer, and the first and the second testing bars [include] *comprise* a second layer different from the first layer.

30. The panel of claim 29, further comprising:

- a plurality of first connecting members connecting the first conductive extensions and the first testing bar; and
- a plurality of second connecting members connecting the second conductive extensions and the second testing bar,

wherein the first and the second connecting members [include] *comprise* a third layer different from the first and the second layer.

* * * * *